

Students' Ways of Thinking about Combinatorics Solution Sets

by

Aviva Halani

A Dissertation Presented in Partial Fulfillment
of the Requirements for the Degree
Doctor of Philosophy

Approved June 2013 by the

Graduate Supervisory Committee:

Kyeong Hah Roh, Chair
Susanna Fishel
Luis Saldanha
Patrick Thompson
Michelle Zandieh

ARIZONA STATE UNIVERSITY

August 2013

ABSTRACT

Research on combinatorics education is sparse when compared with other fields in mathematics education. This research attempted to contribute to the dearth of literature by examining students' reasoning about enumerative combinatorics problems and how students conceptualize the set of elements being counted in such problems, called the *solution set*. In particular, the focus was on the stable patterns of reasoning, known as *ways of thinking*, which students applied in a variety of combinatorial situations and tasks. This study catalogued students' ways of thinking about solution sets as they progressed through an instructional sequence. In addition, the relationships between the catalogued ways of thinking were explored. Further, the study investigated the challenges students experienced as they interacted with the tasks and instructional interventions, and how students' ways of thinking evolved as these challenges were overcome. Finally, it examined the role of instruction in guiding students to develop and extend their ways of thinking.

Two pairs of undergraduate students with no formal experience with combinatorics participated in one of the two consecutive teaching experiments conducted in Spring 2012. Many ways of thinking emerged through the grounded theory analysis of the data, but only eight were identified as *robust*. These robust ways of thinking were classified into three categories: Subsets, Odometer, and Problem Posing.

The *Subsets* category encompasses two ways of thinking, both of which ultimately involve envisioning the solution set as the union of subsets. The three ways of thinking in *Odometer* category involve holding an item or a set of items constant and

systematically varying the other items involved in the counting process. The ways of thinking belonging to *Problem Posing* category involve spontaneously posing new, related combinatorics problems and finding relationships between the solution sets of the original and the new problem. The evolution of students' ways of thinking in the Problem Posing category was analyzed. This entailed examining the perturbation experienced by students and the resulting accommodation of their thinking. It was found that such perturbation and its resolution was often the result of an instructional intervention. Implications for teaching practice are discussed.

ACKNOWLEDGEMENTS

I would like to thank the large number of people who have provided me with encouragement and support throughout my graduate study – I never would have been able to write this dissertation without them. First, I would like to thank my adviser, Dr. Kyeong Hah Roh, for piquing my interest in mathematics education. She has been a valuable source of support and an excellent sounding board for my ideas. I truly appreciate all of her feedback and guidance throughout this program. I would also like to thank my other committee members, Dr. Susanna Fishel, Dr. Luis Saldana, Dr. Patrick Thompson, and Dr. Michelle Zandieh. They have helped me grow as a researcher by graciously providing their time and energy to discuss my research. My thanks especially goes to Pat Thompson for never getting frustrated (or at least not showing his frustration) while I struggled with defining and identifying *ways of thinking* during the RUME classes. I am also grateful for the help I've received from numerous members of the faculty and staff in both the School of Mathematical and Statistical Sciences at ASU and the Department of Mathematics at Wellesley. I am particularly appreciative of all of the help Debbie Olson has given me over the years. She has always had the answers to even the most inane questions I've asked and has been a wonderful friend.

I could never have gotten through graduate school without the support of my friends. I'd like to express my thanks to my colleagues in the math education program. I appreciate the discussions I've had with them, the conversations we've had at happy hour, and their companionship at conferences. I'd particularly like to thank my academic younger brother, Owen Davis, for always providing thoughtful feedback on my work and

a willing ear when I needed to vent. I'd also like to thank my other friends in Arizona – graduate school wouldn't have been the same without potlucks, game nights, and their friendship. In particular, my gratitude goes out to Dr. Jenifer Boshes, Dr. Michael La Marca, and Dr. Gil Mendez, and Dr. Matt Smith for sharing feedback and stories from their time at ASU.

Words cannot express my gratitude for the encouragement I've received from my family throughout the years. My parents have always instilled in me the importance of education and they stimulated my love for math when I was young. I attribute my passion for mathematics and for education to them. I'd also like to thank my brother, Khalif, for always being there for me and for editing this entire document in just two days. I will be eternally grateful to Chandan Das for never letting me give up on graduate school despite how hard things were at times. I could never have made it this far without his support.

TABLE OF CONTENTS

	Page
LIST OF TABLES	xiii
LIST OF FIGURES	xiv
LIST OF EXCERPTS	xiv
CHAPTER	
1. INTRODUCTION	1
1.1. Statement of the Problem	2
1.2. Research Questions	4
2. THEORETICAL PERSPECTIVES	6
2.1. Philosophical Standpoint.....	6
2.2. Development of Mathematical Knowledge	8
2.3. Students' Mathematical Knowledge	10
2.3.1. Ways of thinking about combinatorics	14
2.3.1.1. Generalized Odometer	14
2.3.1.1.1. Solution driven by Generalized Odometer.....	14
2.3.1.2. Equivalence Classes.....	16
2.3.1.2.1. Solution driven by Equivalence Classes	19
2.4. Role of Instruction under Radical Constructivism.....	21
2.4.1. Instructional provocations	23
2.4.1.1. Contrasting Prompts.....	23
2.4.1.2. Potentially Pivotal-Bridging Examples.....	26
2.4.1.3. Stimulating Questions	27
2.4.1.4. Devil's Advocate.....	27

CHAPTER	Page
2.4.2. Pedagogical content tools.....	29
3. LITERATURE REVIEW.....	32
3.1. Combinatorial Reasoning in Children.....	32
3.2. A Model of Students' Combinatorial Thinking.....	41
3.3. Classification of Combinatorial Models.....	44
3.4. Literature with Narrow Foci.....	46
4. RESEARCH METHODOLOGY.....	51
4.1. Members of the Teaching Experiment.....	54
4.1.1. Students.....	54
4.1.2. Teaching agent.....	55
4.1.3. Outside perspective.....	56
4.2. Structure of the Designed Study.....	57
4.2.1. Individual interviews.....	58
4.2.1.1. Individual Interview 1.....	59
4.2.1.2. Individual Interview 2.....	60
4.2.1.3. Individual Interview 3.....	60
4.2.2. Paired sessions.....	61
4.3. Implementation of the Designed Study.....	62
4.3.1. Data sources.....	63
4.3.2. Order of the sessions.....	64
4.4. Tasks.....	65
4.4.1. General protocol.....	65

CHAPTER	Page
4.4.2. Overview of tasks.....	68
4.4.2.1. Task 1: Mississippi I.....	70
4.4.2.2. Task 2: Dice.....	71
4.4.2.3. Task 16: Sororities.....	72
4.4.2.4. Task 18: Table.....	72
4.4.2.5. Task 22: Smoothie.....	74
4.4.2.6. Task 26: Arizona.....	76
4.4.2.7. Task 31: Mississippi II.....	77
4.5. Methods of Analysis.....	78
4.5.1. Pass 0 – Preliminary framework.....	79
4.5.2. Pass 1 – Content logs and note-taking.....	80
4.5.3. Pass 2 – Creation of coding scheme.....	82
4.5.3.1. Criteria for robust ways of thinking.....	82
4.5.3.1.1. Broken Odometer.....	84
4.5.3.1.2. Disney.....	86
4.5.3.1.3. Weak Problem Posing.....	88
4.5.3.2. Final framework.....	93
4.5.4. Pass 3 – Transcription of the data and coding of transcripts.....	95
4.5.5. Pass 4 – Analysis of evolution of ways of thinking.....	98
5. SUBSETS WAYS OF THINKING.....	99
5.1. Subsets Ways of Thinking from the Framework.....	100
5.1.1. Addition.....	101

CHAPTER	Page
5.1.2. Union.....	104
5.2. Over Counting and Subsets Thinking	108
5.2.1. Example of over counting with Subsets thinking	108
5.3. Visualization of Subsets Thinking	110
5.3.1. Venn Diagram Activity	111
5.3.1.1. Two Set Venn Diagram Activity.....	112
5.3.1.2. Three Set Venn Diagram Activity	115
5.3.2. Al’s use of Venn diagrams	118
6. ODOMETER WAYS OF THINKING	122
6.1. Odometer Ways of Thinking from the Framework	123
6.1.1. Standard Odometer.....	124
6.1.2. Wacky Odometer	128
6.1.3. Generalized Odometer	132
6.2. Relationships between Odometer Ways of Thinking	135
6.3. Visualizations of Odometer Thinking.....	136
6.3.1. Tables	137
6.3.1.1. Student spontaneous use of tables.....	137
6.3.1.2. Introduction of tables through instruction.....	139
6.3.1.3. Student subsequent use of tables.....	141
6.3.2. Tree diagrams.....	143
6.3.2.1. Student spontaneous use of tree diagrams	144
6.3.2.2. Introduction of tree diagram through instruction	148

CHAPTER	Page
6.3.2.3. Student subsequent use of tree diagrams	152
6.3.2.3.1. Kate's use of tree diagrams	153
6.3.2.3.2. Boris' use of tree diagrams	154
7. PROBLEM POSING WAYS OF THINKING	157
7.1. Problem Posing Ways of Thinking from the Framework	158
7.1.1. Deletion	159
7.1.2. Equivalence Classes	161
7.1.3. Ratio	165
7.2. The Evolution of Problem Posing Ways of Thinking	170
7.2.1. Weak Problem Posing	173
7.2.1.1. Example from the data (Kate)	174
7.2.1.2. Comparison to Emily	176
7.2.2. Weak Problem Posing → Deletion	177
7.2.2.1. Transition from Weak Problem Posing	177
7.2.2.1.1. Example from the data (Kate)	178
7.2.2.1.2. Comparison to Emily	179
7.2.2.2. Transitioning to true Deletion thinking	180
7.2.3. Deletion → Equivalence Classes	182
7.2.3.1. Perturbation because of limitation of Deletion thinking	183
7.2.3.1.1. Example from the data (Boris)	183
7.2.3.1.2. Comparison to Emily	185
7.2.3.2. Equivalence Classes as accommodation of Deletion thinking	185

CHAPTER	Page
7.2.3.2.1. Example 1 from the data (Boris).....	186
7.2.3.2.2. Comparison to Emily	187
7.2.3.2.3. Example 2 from the data (Kate).....	188
7.2.3.2.4. Comparison to Emily	189
7.2.4. Equivalence Classes \rightarrow Ratio	190
7.2.4.1. Perturbation because of limitation of Equivalence Classes	191
7.2.4.1.1. Example from the data (AI)	191
7.2.4.1.2. Comparison to Emily	193
7.2.4.2. Ratio as an accommodation of Equivalence Classes	194
7.2.4.2.1. Example from the data (AI)	194
7.2.4.2.2. Comparison to Emily	195
7.3. Visualizations of Problem Posing Thinking	195
7.3.1. Deletion	196
7.3.1.1. Venn Diagram representation with superfluous aspects	196
7.3.1.2. Venn Diagram representation with universal set	199
7.3.2. Equivalence Classes	201
7.3.2.1. Visualizations introduced to students.....	201
7.3.2.1.1. Tables	201
7.3.2.1.2. Mapping diagrams.....	206
7.3.2.2. Venn diagrams	208
8. DISCUSSION AND CONCLUDING REMARKS.....	212
8.1. Results in Terms of Research Questions.....	214

CHAPTER	Page
8.1.1. Cataloguing students' ways of thinking about solution sets	214
8.1.2. Relationships between students' ways of thinking	217
8.1.2.1. Subsets category.....	217
8.1.2.2. Odometer category	218
8.1.2.3. Problem Posing category.....	220
8.1.3. Evolution of ways of thinking.....	221
8.1.3.1. Weak Problem Posing evolves to Deletion.....	222
8.1.3.2. Deletion evolves to Equivalence Classes	224
8.1.3.3. Equivalence Classes evolves to Ratio	225
8.1.4. Role of instruction.....	225
8.1.4.1. Creating sources of perturbation	226
8.1.4.1.1. Devil's Advocate.....	227
8.1.4.1.2. Other instructional provocations	229
8.1.4.2. Encouraging visual representations	231
8.1.4.2.1. Venn Diagram Activity	231
8.1.5. Limitations of the study	233
8.2. Implications for the teaching of combinatorics.....	234
8.2.1. Developing mathematical knowledge for teaching combinatorics	235
8.2.2. Implementing instructional interventions	236
8.2.2.1. Addressing misconceptions.....	236
8.2.2.2. Fostering robust ways of thinking.....	237
8.2.2.3. Strengthening ways of thinking	238

CHAPTER	Page
8.2.3. Designing combinatorics curricula	239
8.3. Further Discussion	240
8.3.1. Relation to the existing literature	240
8.3.1.1. Ways of thinking, heuristics, and strategies.....	240
8.3.1.2. Model of combinatorial thinking	243
8.3.1.3. Actor-oriented transfer	245
8.3.2. Future research	246
REFERENCES	248
 APPENDIX	
A. TASKS AND PROTOCOLS DESIGNED FOR PHASE 2	254
B. SAMPLE CONTENT LOG.....	297
C. INFORMATIONAL LETTER GIVEN TO STUDENTS	311
D. HUMAN SUBJECTS APPROVAL FORM.....	313
E. REFLECTION FORM.....	315

LIST OF TABLES

Table	Page
1. Schedule for research activities	52
2. Names and participants of the sessions in each phase	64
3. Sessions and tasks for each phase	69
4. Tasks and combinatorial operations.....	70
5. Passes of data analysis	78
6. Initial framework of ways of thinking	80
7. Ways of thinking about combinatorics solution sets	94
8. Coding scheme.....	95
9. Example of coded data from P1_PS2	97
10. Subsets ways of thinking	101
11. Odometer ways of thinking.....	124
12. Problem Posing ways of thinking	158
13. Problem Posing ways of thinking observed from specific sessions	172

LIST OF FIGURES

Figure	Page
1. Punched cards illustration of assimilation	9
2. Reproduction of Solution 1.1 in Harel & Sowder (2005, p. 31)	12
3. Equivalence Classes	17
4. Equivalence Classes for the WELLESLEY problem	20
5. An example of Devil's Advocate	28
6. Reproduction of tree diagram for dressing bears from English (1993, p.147)	36
7. Structure of designed study	58
8. Example of Disney Thinking	86
9. Example of a solution driven by Frank's way of thinking	92
10. Al's written work for Task 16 (iii): Sororities	107
11. Two set Venn Diagram Activity from P2_S4	114
12. Three Set Venn Diagram Activity from P2_S5	116
13. Al's Venn diagram for Union thinking from Task 16(iii) in P2_S6	120
14. Partial tree diagram modeling Al's Standard Odometer thinking	127
15. Standard Odometer thinking for permuting {A, B, C, D}	130
16. Wacky Odometer thinking for permuting {A, B, C, D}	131
17. Partial tree diagram modeling Boris' Generalized Odometer thinking	133
18. Tom's table for Standard Odometer thinking in the Dice problem	138
19. Al's solution for Task 7: Balls	142
20. Al's tree diagram for permuting MISP through Standard Odometer	146
21. Al's factor tree	148

Figure	Page
22. Kate’s list of elements for Task 11: Grandma	149
23. “Annette’s Solution” for Task 11: Grandma	150
24. “Toni’s solution” to Task 12: Lotto	152
25. Kate’s tree diagram for Task 13: Committee 2.....	153
26. Boris’ tree diagram for Task 14(vi): Letters abcdef	156
27. Deletion.....	160
28. Equivalence Classes.....	163
29. A model of Kate’s Equivalence Classes for Task 26: Arizona.....	164
30. Ratio thinking.....	167
31. A model of Al’s Ratio thinking for Task 2: Dice	168
32. Model of the evolution of Emily’s Problem Posing ways of thinking	172
33. First Stage of Pat’s Argument for Equivalence Classes thinking.....	186
34. Al’s Venn diagram for Deletion thinking from Task 14(vi).....	198
35. Venn diagram for Deletion thinking for Task 30(v).....	200
36. Sara’s diagram for the Table problem with three people.....	202
37. Sara’s diagram for the Table Problem with four people.....	203
38. Kate and Boris’ table representation for Task 21: Necklace	205
39. Mapping diagram for Vince’s argument for Task 28	208
40. Al’s Venn Diagram for Equivalence Classes thinking from session 9	210
41. Evolution of Problem Posing thinking for Kate, Boris, and Al.....	222

LIST OF EXCERPTS

Excerpt	Page
1. Permutation of four distinct cards from Pilot Study 1	87
2. Permutation of WELLESLEY from Pilot Study 1	89
3. Task 6: Books from P1_PS1	102
4. Task 6: Books from P1_PS1	105
5. Task 14(vi): Letters abcdef in P1_PS1	109
6. Task 16(iii): Sororities from P2_S6.....	119
7. Task 16(iii): Sororities from P2_S6.....	120
8. Task 8(i): Fraternities from P2_S3	125
9. Task 14(ii): Letters abcedf from P1_PS2.....	128
10. Task 29: Cards from P1_PS5.....	133
11. Task 2: Dice from Pilot Study 1	137
12. Task 4: 2-digit numbers from P2_II1.....	140
13. Variation of Task 1: Mississippi I from P2_II1	144
14. Variation of Task 1: Mississippi I in P2_II1	147
15. Task 11: Grandma from P1_PS2	150
16. Task 16(iii): Sororities from P1_II2_K.....	159
17. Task 26: Arizona from P1_PS4	162
18. Revisit Task 2: Dice from P2_S8.....	165
19. Variation of Task 1: Mississippi 1 from P1_II1_K	175
20. Task 5: Security Codes from P1_II1_K.....	178
21. Task 18: Table from P1_II2_K.....	189

Excerpt	Page
22. Revisit Task 2: Dice in P2_S8	193
23. Revisit Task 2: Dice in P2_S8	194
24. Task 14(vi): Letters abcdef from P2_S5	197
25. Discussion of visual representations from P2_S9	209
26. Task 31: Mississippi II from P2_S9.....	211

1. INTRODUCTION

Discrete mathematics explores the properties and relations among discrete structures, where the objects have distinct, separated values. The subject has strong connections to computer science, optimization, and statistics. Some believe that the use of discrete structures may foster a deeper understanding of mathematics because they are sometimes easier to understand than continuous structures (Heinze, Anderson, & Reiss, 2004). Furthermore, Kapur (1970) indicated that the powerful methods of continuous mathematics are such that many students can apply them without deep understanding of the concepts, whereas the methods of discrete mathematics are not as powerful and so applications almost always require ingenuity.

Combinatorics is an important branch of discrete mathematics which concerns the study of finite or countable discrete structures. Combinatorial problems often deal with *enumeration* (the counting of discrete structures of a certain size or type), *existence* (determining whether certain structures exist), *construction* (constructing certain discrete structures), and *optimization* (finding the “largest”, “smallest”, or “optimal” discrete structure of a certain kind). This study is concerned solely with enumerative combinatorics; however, for simplicity, it will be referred to as “combinatorics,” and its problems will be called “counting problems” or “combinatorics problems.”

Combinatorics, one of the oldest branches of discrete mathematics, dates back to the 16th century when games of chance played a role in society (Abromovich & Pieper, 1996). Specific counting techniques and mathematical ideas related to the real-life situations were created to provide the theory for these games. Fermat and Pascal, during

their theoretical pursuit of combinatorial problems, “laid a foundation for the theory of probability and provided approaches to the development of [...] combinatorics as the study of methods of counting various combinations of elements of a finite set” (Abromovich & Pieper, 1996, p. 4).

Recently, discrete mathematics has gained prominence as a field of mathematics and it has strong connections to other subjects. For example, in probability, when all outcomes are equally likely to happen, the probability that event A occurs is

$P(A) = \frac{N(A)}{N}$, where $N(A)$ is the number of outcomes leading to the occurrence of A and

N is the total number of outcomes (Batanero, Godino, & Navarro-Pelayo, 1997a). It is essential to be able to count these outcomes in order to determine discrete probabilities. Indeed, combinatorics has been said to be “the backbone of probability” (Freudenthal, 1973). In addition, combinatorics can be used in computer science to create formulas and estimates while analyzing algorithms. Furthermore, discrete mathematics can be used in operations research (e.g. scheduling and vehicle routing), biology (e.g. maps of DNA), and chemistry (e.g. isomer enumeration techniques) to name a few (Kavousian, 2008).

1.1. Statement of the Problem

Existing research in combinatorics education has focused on the following areas: combinatorial reasoning in children (English, 1991, 1993, 2005; Piaget & Inhelder, 1975; Shin & Steffe, 2009), student thinking about combinatorics from set-oriented and process-oriented perspectives (Lockwood, 2010, 2011a), classification of combinatorial models (Batanero et al., 1997a; Batanero, Godino, & Navarro-Pelayo, 1997b; Dubois,

1984), and formulae students use while solving combinatorics problems (CadwalladerOlsker, Annin, & Engelke, 2011). In addition, the context of combinatorial problems has been adopted for use in research studies involving verification strategies (Eizenberg & Zaslavsky, 2004), semiotics (Godino, Batanero, & Roa, 2005), and intuition (Fischbein & Grossman, 1997).

According to Piaget and Inhelder (1975) children's combinatorial reasoning is a fundamental mathematical idea based in additive and multiplicative reasoning. Indeed, as Kavousian (2008) said "without much prior knowledge of mathematics, one can solve many creative, interesting, and challenging combinatorial problems" (p. 2). This indicates that students, even young children, should be able to solve many combinatorial problems by employing their additive and multiplicative reasoning. However, the research indicates that students of all ages often struggle to solve counting problems (Batanero et al., 1997a, 1997b; Eizenberg & Zaslavsky, 2004; English, 1991, 1993). Indeed, there is evidence of low student success rates on a variety of different types of combinatorial problems both before and after instruction (Batanero et al., 1997b; Lockwood, 2011a).

In order to address these difficulties, some studies have investigated student errors (Batanero et al., 1997a, 1997b; Hadar & Hadass, 1981; Kavousian, 2008) and formulae students use to respond to particular combinatorial problems (CadwalladerOlsker et al., 2011). Still, however, much of the prior research on combinatorics education has focused on students' actions, not their reasoning and understanding. It is widely accepted by mathematics educators that just because a student can *do* something, this does not mean that the student fully comprehends the topic, or that the student is applying coherent reasoning (Carlson, Jacobs, Coe, Larsen, & Hsu, 2002; Roh & Halani, 2011; A. G.

Thompson & Thompson, 1994a; P. W. Thompson & Thompson, 1994b). Thus, it is not enough to examine students' actions as they solve particular combinatorics problems – it is essential to understand their reasoning as well. Further, it would be foundational to understand the stable patterns in reasoning that students apply in a variety of combinatorial situations and tasks. Such coherent patterns in reasoning have been called *ways of thinking* (Harel, 2008).

1.2. Research Questions

The purpose of this research is to understand college students' reasoning about combinatorics problems and how students conceptualize the set of elements being counted, called *solution sets*. To this end, this study attempted to classify students' ways of thinking about solution sets and to model the evolution of students' ways of thinking as they progressed through an instructional sequence. The tasks in this sequence involved arrangements with and without repetition, permutations of distinct elements, combinations, and permutations with repeated elements. The phrasing of the tasks was similar to those in traditional textbooks. Thus, this study investigated students' ways of thinking about solution sets of problems normatively taken to be combinatorial in nature.

In particular, this study aimed to answer the following research questions:

1. What are students' ways of thinking about combinatorics solution sets?
2. What are the relationships between students' ways of thinking about combinatorics solution sets?

3. To what extent do students' ways of thinking about combinatorics solution sets evolve as the students resolve the challenges they experience as they interact with tasks and instructional interventions?
4. In what ways, and to what extent, might naïve students be guided to develop and extend their current ways of thinking about combinatorics solution sets?

Combinatorics is often taught in a classroom setting and students typically interact not only with the tasks and the teacher, but also with each other. In order to closely model the evolution of students' ways of thinking as it might happen in a classroom setting, this study investigated students' ways of thinking about sets of elements being counted by engaging college students in two small-group teaching experiments. Both teaching experiments were designed to foster two ways of thinking called *Equivalence Classes* and *Generalized Odometer*. This methodology was chosen so that the researcher could examine each student's reasoning in each task, track the evolution of each student's ways of thinking, and also so that the researcher could easily attend to the interactions between the students, the tasks, and the researcher.

2. THEORETICAL PERSPECTIVES

This study's underlying theoretical perspectives are made explicit in this chapter. These perspectives ground the study's design and analysis. To begin, cognitive psychologists' philosophical standpoint on knowledge acquisition and the role of teaching is discussed – this standpoint informed the choice of methodology for the study and served as the fundamental perspective adopted in this study. Then, this study's perspective on the development of students' mathematical knowledge is presented. Piaget's theory of knowledge development is discussed as it served as a basis for analyzing the development of students' knowledge throughout the study. Here, students' mathematical knowledge is defined in terms of Harel's constructs of *ways of understanding* and *ways of thinking* (Harel, 2008; Harel & Sowder, 2005). Finally, this study's perspectives on the role of instruction under radical constructivism, primarily Roh and Halani's *instructional provocations* (2011) and Rasmussen and Marrongelle's (2006) *pedagogical content tools*, are elaborated upon.

2.1. Philosophical Standpoint

The philosophical perspective underlying this study is that “knowledge is not passively received either through the senses or by way of communication, but it is actively built by the cognizing subject” (von Glasersfeld, 1995, p. 51). Indeed, although an instructor might explain a concept to a class of students, each individual student experiences the information in his or her own way. Because each student's knowledge is constructed by the individual, conceptions are mental structures that cannot be passed from one mind to another.

It might seem as though social interaction has no effect on an individual's construction of knowledge. However, the discussion so far does not imply that other students or an instructor do not play a role in a student's construction of his or her mathematical knowledge. Indeed, according to radical constructivism, social interactions serve as the catalyst for otherwise autonomous psychological development – they might influence the process and speed of the development of the individuals' mathematical knowledge, but not its products (Cobb, 2007).

This view on the acquisition of knowledge situates a mathematics classroom as a place for students to construct their own mathematical knowledge. The role of the instructor then is to orient the students' cognitive processes (von Glasersfeld, 1995). He or she should serve as a facilitator as the students construct their mathematical knowledge – not by mainly lecturing or attempting to transmit knowledge to the students, but by aiding students in their construction of knowledge. Certainly, in order to orient students towards a particular conceptual construction, it would be easier to have an idea of the conceptual structures they are using at the time. So, a mathematics instructor should inquire into students' ways of thinking about the mathematics by building and testing models of students' mathematics, and use these models to advance the mathematical agenda by pushing students to further develop their reasoning and therefore their understanding (Roh & Halani, 2011). In addition, the instructor has the opportunity to influence students' construction of mathematical knowledge by organizing tasks to build upon anticipated ways of thinking and implementing instructional interventions to guide students to develop these ways of thinking. In order to do this, the instructor might find it helpful to consider epistemic students. An *epistemic subject* is the mental construction of

a non-specific individual with particular ways of thinking (P. W. Thompson, in press; P. W. Thompson & Saldanha, 2000; von Glasersfeld, 1995). When considering an epistemic person, the instructor would not be imagining any particular person. Instead, she could imagine that the epistemic individual has a particular way of thinking and make conjectures about how that non-specific individual would respond in certain situations. Thus, when teaching a class of 30 students, the instructor would not need to necessarily attend to 30 different mathematical realities, but attend to five or six epistemic individuals and “listen to which fits the ways particular students express themselves” (P. W. Thompson, in press).

2.2. Development of Mathematical Knowledge

Piaget’s theory of knowledge development is used in this study to analyze how students’ knowledge evolves in the domain of combinatorics. According to Piaget, individuals construct and develop knowledge through a process of assimilation and accommodation (Gruber & Voneche, 1977). Piaget, a biologist, believed that the mind has structures, just as the body does (Piaget, 1980). *Schemata* are the cognitive or mental structures by which individuals intellectually adapt to and organize the environment (Wadsworth, 1996). *Assimilation* occurs when an individual fits an experience into a conceptual structure or schema that already exists (von Glasersfeld, 1995). In other words, the individual treats new experiences in terms of something already known to him or her. The individual integrates the parts of a new experience to an existing cognitive structure and disregards that which does not fit into the existing structure. von Glasersfeld (1995) provides a concrete illustration of assimilation by using the example of a card-sorting machine working with punched cards. Suppose that one asks the machine to

compare given cards with a specific card such as the one on the left in Figure 1. The machine would pick out all of the cards that have these holes regardless of any other holes it might have. The machine does not “see” the other holes and therefore views all of the cards it picks out as equivalent to the model card. In our example, the machine would view the card on the right of Figure 1 as the same as the model card on the left.

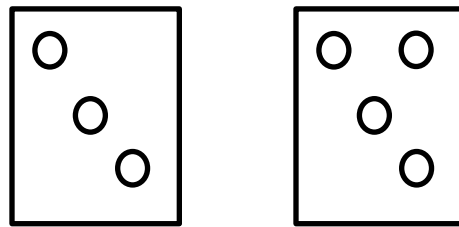

Figure 1. Punched cards illustration of assimilation

To return to the concept of schema, assimilation does not result in a change of schema, but instead affects its growth. One might think of a schema as a hot air balloon. Assimilation then, in this simile, is akin to adding air to the balloon – it would expand it, but not fundamentally change its shape (Wadsworth, 1996).

An *action* is an activity of the mind which may or may not be expressed in observable behavior. A *scheme* is an organization of actions with three properties: “an internal state which is necessary for the activation of actions composing it, the actions themselves, and an imagistic anticipation of the result of acting” (P. W. Thompson, 1994a, p. 5). The activation of actions in the first property is the result of assimilation. If an experiential situation satisfies certain conditions for an individual, it will activate the associated activity. The actions in the second property will yield a result which the

individual will attempt to match to its anticipated result through assimilation. If the individual is unable to do this, he or she will experience a *perturbation*.

The individual might have any number of reactions to this perturbation, but will likely review the initial situation and potentially observe characteristics which were initially disregarded by attempted assimilation. In this case, the individual needs to modify the schema to account for the new experience (von Glasersfeld, 1995). Perturbation might also occur if an individual encounters a situation that he or she is unable to fit to a schema through assimilation because no such schema exists for the person at the time. If this is the case, he or she might account for the new experience and construct a new schema. *Accommodation* is the modification of existing schema, as in the first case, or creation of a new one, as in the second (Piaget, 1980). Once an individual makes an accommodation and his or her schemata change, he or she will once again consider the new experience through assimilation.

In line with Piaget's theory of knowledge development, this study sought to identify sources of perturbation for students and explore how the students modify schemata as they deal with new experiences through assimilation and accommodation.

2.3. Students' Mathematical Knowledge

Harel (2008) contends that there are two different categories of mathematical knowledge: "ways of understanding" and "ways of thinking." Humans' reasoning "involves numerous *mental acts* such as interpreting, conjecturing, inferring, proving, explaining, structuring, generalizing, applying, predicting, classifying, searching, and

problem solving” (Harel, 2008, p. 3). This study pays particular attention to the mental act of problem solving.

Ways of understanding refers to the reasoning applied to a particular mathematical situation – the cognitive products of mental acts carried out by a person (Harel & Sowder, 2005). For example, consider the mental act of problem solving. The exact solution provided by a student represents a way of understanding since it is the product of the problem solving act.

Ways of thinking, on the other hand, refer to what governs one’s ways of understanding – the cognitive characteristics of mental acts – and are always inferred from ways of understanding (Harel & Sowder, 2005). For example, certain problem solving approaches might become clear as the student progresses through different tasks while engaging in the problem solving mental act. These approaches could include “examine special cases,” “just look for key words,” and “exploit a similar problem.” These are ways of thinking since they are characteristics of the students’ problem solving acts. Reasoning involved in ways of thinking does not apply to one particular situation, but to a multitude of situations (Harel, 2008). According to Harel (2008), ways of understanding and ways of thinking thus comprise mathematical knowledge.

To further clarify the distinction between ways of thinking and ways of understanding, Harel & Sowder (2005) include the following problem and solution:

Problem: A pool is connected to 2 pipes. One pipe can fill the pool in 20 hours, and the other in 30 hours. Assuming the water is flowing at a constant rate, how long will it take the 2 pipes together to fill the pool?

Solution 1.1: In 12 hours, the first pipe would fill $\frac{3}{5}$ of the pool and the second pipe the remaining $\frac{2}{5}$ (p. 30).

6	6	4	4	4
---	---	---	---	---

Figure 2. Reproduction of Solution 1.1 in Harel & Sowder (2005, p. 31)

According to Harel and Sowder (2005), as the student attempted to solve the problem above, he or she engaged in the problem solving mental act. A product of this mental act was Solution 1.1, so this exact solution represents a way of understanding. The ways of thinking, or cognitive characteristics of the act, that might have driven the solution could have consisted of “draw a diagram,” “guess and check,” and “look for relevant relationships among the given quantities” (Harel & Sowder, 2005).

All of the examples of ways of thinking provided so far could be termed *heuristics* (Polya, 1957; Schoenfeld, 1992), or “rules of thumb for effective problem solving” (Schoenfeld, 1985, p. 23), but heuristics and ways of thinking are not the same thing. Indeed, the simple heuristic “examine special cases” gives rise to multiple different special cases strategies depending on the type of problem to which it is being applied (Schoenfeld, 1992). Thus, there could be different ways of thinking related to the same heuristic depending on the mathematical domain. Further, although all heuristics are general approaches to solving problems, students’ problem solving approaches are not always heuristics (Harel & Sowder, 2005).

Consider the following example of students’ problem solving approaches in mathematics which would not be termed a “heuristic.” Students in a calculus class attempted to explain why the rate of change of volume with respect to height in a cone

was equal to the cross-sectional area at that height: Consider a thin slice of water at the top of the cone. As you let the slice get thinner and thinner, the height will eventually be 0 and you will be left with an area (P. W. Thompson, 1994b). The particular argument provided by the students is a way of understanding because it is the cognitive product of mental acts. Underlying this way of understanding is a way of thinking in which students might engage in order to reason about limits, which Oehrtman (2002) called the “collapsing metaphor.” In this case, they reasoned that one object would approach another object having one less dimension. As such, to a student engaging in this way of thinking, volumes would collapse into areas, areas into lines, and so forth. Notice that this reasoning does not simply apply to the cone example above, but to a multitude of situations. As such, it is a characteristic of mental acts and is therefore a way of thinking – it is an approach to solving limit problems, but it is not a heuristic.

Notice that the problem solving approaches suggested above all involve various mental acts in which students might engage. It is important to note that a student’s mental act applied to solve simply one problem situation would not be necessarily considered as his or her way of thinking because ways of thinking apply to a multitude of situations. When applicable to various different situations, on the other hand, the student’s mental act of problem solving can be regarded as his or her way of thinking. Thus, while it is possible to hypothesize the ways of thinking a student might be engaging in while solving a particular problem, as in the examples above, it is necessary to delve further to ascertain the ways of thinking driving a solution.

2.3.1. Ways of thinking about combinatorics

The author previously contributed to research in combinatorics education by identifying several ways of thinking in which students engage to reason about solution sets (Halani, 2012a, 2012b). *Generalized Odometer* (Halani, 2012b) and *Equivalence Classes* (Halani, 2012a), two important ways of thinking identified, are discussed in this Section. This study sought to foster these particular ways of thinking in the students.

2.3.1.1. Generalized Odometer

Generalized Odometer entails the following sequence of mental acts: First, determine the number of ways to place a set of items. Next, for each one of these placements, vary items in the other positions in an effort to generate all of the elements in the solution set. In essence, a student engaging in Generalized Odometer thinking would be holding placements of the original set of items constant while placing the other items involved in the counting process. This way of thinking provides a way for students to systematically generate all elements of the solution set permutation with repetition problems. The power of this way of thinking is illustrated in the following example.

2.3.1.1.1. Solution driven by Generalized Odometer

If a student were to reason about the solution set of a combinatorics problem by engaging in Generalized Odometer, she might determine that there are $\binom{9}{3} \cdot \binom{6}{3} \cdot 3!$ ways to permute the letters in WELLESLEY. Indeed, her reasoning could be that the elements of the solution set involve nine slots: _____ . She would realize that she could choose three of these slots for the Es. There are $\binom{9}{3}$ ways to place the Es. She would

argue that in each of these placements, there are six remaining empty slots. For example,

the placement E _ E _ _ E _ _ _ involves 6 empty slots. For each of these $\binom{9}{3}$

placements, there are $\binom{6}{3}$ ways to place the Ls. For example, in the placement shown

before, the Ls could be placed as follows: E L E L _ E _ L _ . Now, in each of these

placements, there are three empty lots in which the remaining three letters must be

placed. For each of these $\binom{9}{3} \cdot \binom{6}{3}$ placements, there are $3!$ ways to place the remaining

letters. Altogether, there are $\binom{9}{3} \cdot \binom{6}{3} \cdot 3!$ total ways to rearrange the letters in

WELLESLEY.

In the previous argument, the student determined the number of ways to place the Es in the given number of slots and then held these placements constant while

determining the number of ways to place the remaining items (the Ls, W, Y, and S). The

student instead could have reasoned that there are $\binom{9}{3}$ ways to place the Ls and that for

each of those placements, there are $\binom{6}{3} \cdot 3!$ ways to place the other items, yielding the

same expression for the solution. Alternatively, she could have argued that there are

$\binom{9}{3} \cdot 3!$ ways to place the W, Y, and S, with $\binom{6}{3}$ ways to place the other items for a total

of $\binom{9}{3} \cdot 3! \cdot \binom{6}{3}$ as the final solution. All of these arguments were driven by Generalized

Odometer thinking – common to all of them is the idea of determining the number of ways of placing a set of items at a time and holding these placements constant while determining the number of ways to place the other items.

Generalized Odometer was chosen as a way of thinking to be fostered in this study because it seemed as if it could help students coordinate solution sets with an associated counting process, and vice versa. Here, a *counting process* refers to the enumeration process, or set of processes, in which a counter engages while solving a combinatorics problem (Lockwood, 2011a). A process associated with permuting the letters in WELLESLEY could have involved choosing where to place the Es, where to place the Ls, and then where to place the remaining letters. However, in the solution above, the epistemic student was not simply implementing a counting process, but reasoning about the solution set. Therefore, Generalized Odometer is a way of thinking about solution sets. Moreover, it is a particularly powerful way of thinking since it may help students coordinate solution sets with counting processes. The importance of such coordination is discussed further in Section 3.2 below.

2.3.1.2. Equivalence Classes.

Equivalence Classes thinking entails the following sequence of mental acts: First, consider a given task with solution set A . Second, pose a related problem with a solution set S which can be partitioned into blocks of the same size, each of which is in bijective correspondence with an element of A . Third, after constructing these blocks, quantify the size of each block and find a multiplicative relationship between the size of the block and the size of S , in order to find the size of set A . See Figure 3.

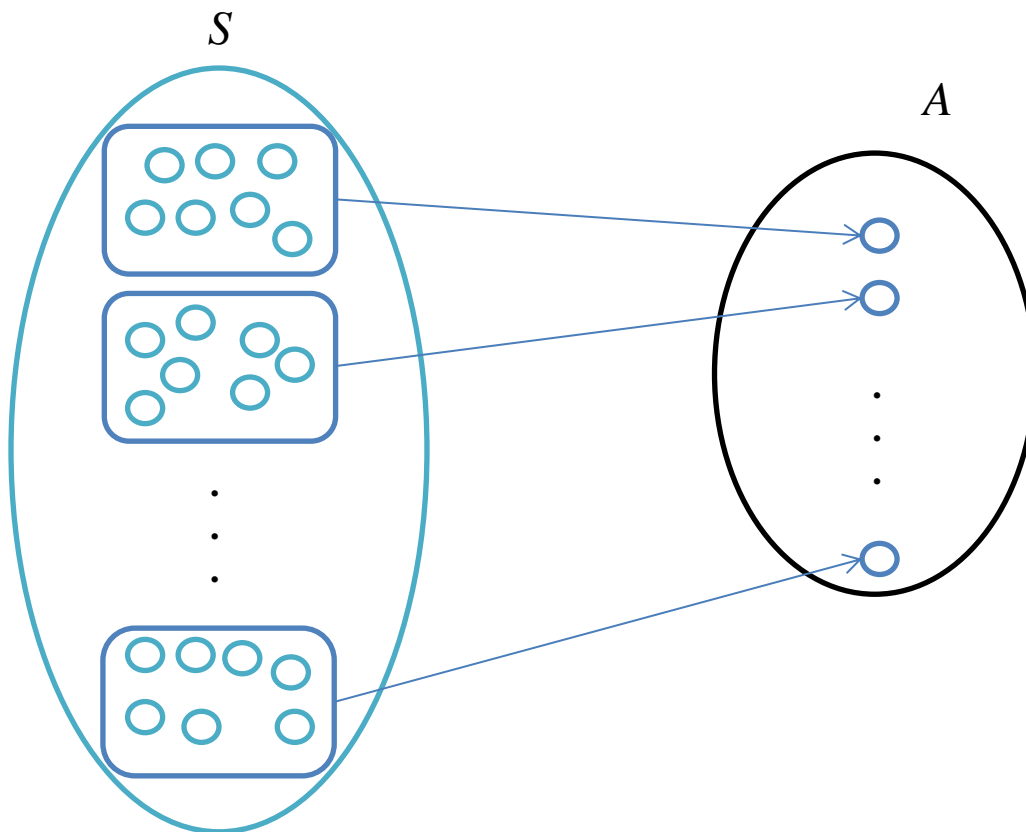

Figure 3. Equivalence Classes

Mathematically, an *equivalence relation* R on a set S is a subset of $S \times S$ such that:

- (i) $\forall x \in S, (x, x) \in R$, (*reflexive property*)
- (ii) $\forall x, y \in S, [(x, y) \in R \rightarrow (y, x) \in R]$, (*symmetric property*) and
- (iii) $\forall x, y, z \in S, [(x, y) \in R \wedge (y, z) \in R] \rightarrow (x, z) \in R$ (*transitive property*).

For example, let S be the set of all people and $R = \{(x, y) \in S \times S \mid \text{person } x \text{ has the same birthday as person } y\}$. In this case, consider that “birthday” refers to the month and day of birth, not the year. Since everyone has the same birthday as himself, R satisfies (i). Since it is true that if person x has the same birthday as person y , then person y has the

same birthday as person x , R satisfies (ii). Finally, if person x has the same birthday as person y and person y has the same birthday as person z , person x has the same birthday as person z . Therefore R satisfies (iii) and is therefore an equivalence relation.

An equivalence relation on a set S partitions S into disjoint parts and each element of S is in a part. Indeed, in our example above we can think of the relation R as breaking the set of people into 366 categories – one for each day of the year. Every person is in a category, and nobody is in more than one. Each category is the set of people who share birthdays. Each one of these partitions is called an *equivalence class* of R . We can also consider the *equivalence class of an element x in S with respect to R* :

$[x]_R = \{y \in S \mid (x, y) \in R\}$, which consists of all other elements of S which are in the same equivalence class as x . If there is only one equivalence relation under consideration, we simply call it the *equivalence class of x* . In our birthday example, the equivalence class of Aviva Halani is the set of people who were born on July 16 and includes American actors Jayma Mays and Will Ferrell.

It is likely that most students engaging in Equivalence Classes thinking would not be considering the formal mathematical structure described above. They probably would not formally construct an equivalence relation and check its reflexivity, symmetry, or transitivity. They also are not likely to create formal equivalence classes. However, they would be able to determine a relation between the two solution sets, partition the new solution set into groups of the same size, quantify the size of each group, and relate the sizes of the groups to the cardinality of the solution sets of both problems. As these groups are actually equivalence classes, though the students might not be aware of this

fact, the term “Equivalence Classes” seems to be an appropriate way to describe their way of thinking.

Because it allows the student to reason about repeated items, Equivalence Classes thinking is another powerful way of thinking for solving counting problems, particularly those involving the operation of permutations with repetition. The following example illustrates the power of Equivalence Classes thinking.

2.3.1.2.1. Solution driven by Equivalence Classes

In the subsection above, the student reasoned about the number of permutations of the letters in WELLESLEY by engaging in Generalized Odometer thinking. Suppose that this epistemic student could engage in Equivalence Classes thinking as well as Generalized Odometer. Then, if she reasons about the number of ways to permute the letters in WELLESLEY by engaging in Equivalence Classes, she would likely determine

the solution to be $\frac{9!}{3!} = \frac{9!}{3! \cdot 3!}$. Indeed, her reasoning could involve first consider the

number of ways to permute the letters in $WE_1L_1L_2E_2SL_3E_3Y$ and would figure out that there are $9!$ of these. She could recognize that a permutation of $WE_1L_1L_2E_2SL_3E_3Y$ would correspond to a permutation of WELLESLEY if the subscripts in the former were removed. She could then see that there are $3!$ ways to permute the E in a permutation of $WE_1L_1L_2E_2SL_3E_3Y$ and each of them would be counted as the same permutation of $WE_1L_1L_2E_2SL_3E_3Y$. She might conclude that there are $3!$ times as many permutations of

$WE_1L_1L_2E_2SL_3E_3Y$ than there are of $WEL_1L_2ESL_3EY$. Thus, there are $\frac{9!}{3!}$ ways to

permute the letters in $WEL_1L_2ESL_3EY$. She might also realize that there are $3!$ ways to

permute the Ls in $WEL_1L_2ESL_3EY$, and each of them would correspond to the same

permutation of WELLESLEY. She could finally conclude there are $\frac{9!}{3!} = \frac{9!}{3! \cdot 3!}$ ways to

permute the letters in WELLESLEY.

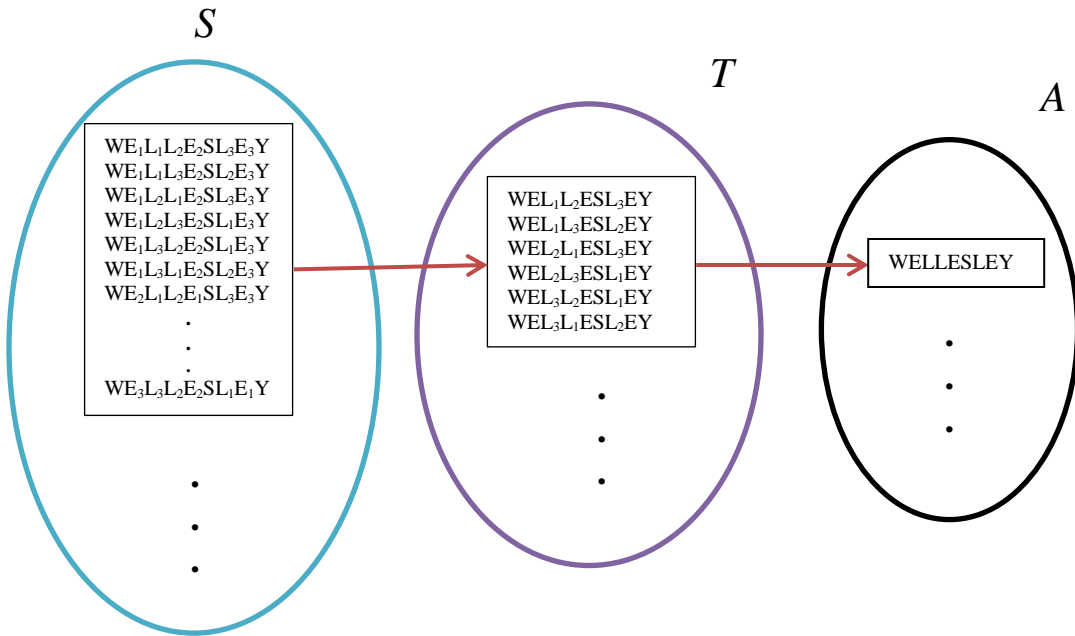

Figure 4. Equivalence Classes for the WELLESLEY problem

In the previous argument, the student posed two new problems. She first created a new problem, with solution set S , in which all of the Ls and Es were distinct objects. So S is the set of all permutations of $WE_1L_1L_2E_2SL_3E_3Y$. The second problem with solution set T involved finding the number of permutations of “ $WEL_1L_2ESL_3EY$.” She then constructed equivalence classes in S based on whether the same “word” would be created if the subscripts of the Es were removed. She identified each of the equivalence classes in S with the set of “words” which would be the same if the subscripts of the L’s were removed from the elements of T . These sets of “words” in T which would be the same if

the subscripts were removed partition T into equivalence classes. Each of the equivalence classes in T correspond to one element of A , the set of permutations of WELLESLEY.

See Figure 4 for a visual representation of these sets and their relationships.

2.4. Role of Instruction under Radical Constructivism

The perspective on the role of instruction adopted in this study is expanded upon in this Section. In a traditional university classroom taught by lecturing, students are invited to enter the lecturer's world (Mason, 2002; Pritchard, 2010). However, under the perspective on the acquisition of knowledge discussed in Section 2.1 and adopted in this study, the students' worlds may not coincide with the lecturer's world. If students construct their own mathematical knowledge, then a mathematics instructor's role is not to lecture or "tell" mathematics to students in the traditional sense. Instead, the instructor's role is to orient the students' cognitive processes (von Glasersfeld, 1995) and aid learners with the construction of their mathematics.

In order to orient students towards a particular conceptual construction, a mathematics instructor should have an idea of what students must understand in order to construct the concept he or she would like the students to understand (Silverman & Thompson, 2008). In this process, it would be easier to have an idea of the conceptual structures they are using at the time. Thus, a mathematics instructor should inquire into students' ways of thinking about the mathematics, building and testing models of students' mathematics, and use these models to advance the mathematical agenda by using these models to push students to further develop their reasoning and therefore their conceptions about the mathematical topic at hand (Roh & Halani, 2011). In addition, the

instructor must have some idea of the type of conceptual change that would constitute an advance for the particular student (von Glasersfeld, 1995).

Since social interactions can serve as a catalyst for otherwise autonomous development (Cobb, 2007), an instructor might use his or her models of students' mathematics to encourage discussions about the topic at hand. The moves an instructor makes to promote discussion in a classroom are referred to as *discursive moves* (Rasmussen, Kwon, & Marrongelle, 2008). An instructor may advance the mathematical agenda by using some discursive moves and models of student thinking to create sources of perturbation for the students, pushing them to accommodate new experiences by modifying existing schemata or creating new ones. In other words, an instructor might provoke students to further develop their reasoning and therefore their understanding. These particular discursive moves were called *instructional provocations* (Roh & Halani, 2011). Instructors might also use the notion of *pedagogical content tool* (PCT) to promote class discussion. A PCT involves both the activity of a teacher intentionally attempting to connect to student thinking and the implement, or tool, that the teacher uses to do so.

This Section first discusses the constructs developed by Roh and Halani (2011) which informed the design of the tasks and protocols in the study. Next, it expands upon pedagogical content tools (Rasmussen & Marrongelle, 2006) with a particular emphasis on visual representations as an implement a teacher could use.

2.4.1. Instructional provocations

Instructional provocation refers to a teacher's action of implementing an intervention, or the intervention itself, which creates a source of potential student perturbation or its resolution (Halani, Davis, & Roh, 2013). In fact, there are types of instructional interventions that may not create sources of perturbation, but rather encourage the student to utilize his or her existing scheme. For example, instructors might scaffold problems so that new tasks build easily upon previous ones. Scaffolding is not considered an instructional provocation because it would not cause a student to experience perturbation.

Instructional provocations are instructional interventions which would entail the accommodation of the student's existing scheme or the creation of a new scheme by the student. This study implemented four types of instructional provocations as follows: Contrasting Prompts, Potentially Pivotal-Bridging Examples, Stimulating Questions, and Devil's Advocate.

2.4.1.1. Contrasting Prompts

Roh and Halani (2011) called an instructional intervention *Contrasting Prompts* when it is in the form of a pair of statements, provided by an instructor to students, one of which either sounds similar to but is not logically equivalent to the other, or sounds logically equivalent but is not similar to the other. For example, if students are not aware of the hierarchical relationship between squares and rectangles, then an instructor would be implementing Contrasting Prompts if she suggests that students contrast the statements "every rectangle is a square" and "every square is a rectangle." A student contrasting the

statements might experience a perturbation and attend to the hierarchical relationship between the two geometric shapes.

It should be noted that the whether the two statements in Contrasting Prompts sound the same is not determined by mathematicians or the designer of the intervention, but is rather subject to individual students who encounter the prompts. Hence, for some students the statement “every rectangle is a square” might sound similar to the statement “every square is a rectangle” whereas for some other students the two statements might not sound similar to one another. Roh and Halani’s (2011) study provided an instructor’s use of a pair of statements as an example of Contrasting Prompts that entailed students’ recognition of subtle differences in meaning between two statements and which raised the students’ awareness of a certain aspects of logic that caused the subtle differences in the pair of statements.

In the current study, the researcher extended Contrasting Prompts to include a pair of arguments as well as a pair of statements. Indeed, in this study, Contrasting Prompts was often implemented by having students compare arguments or solutions to the same task. For example, consider the following situation, question, and pair of arguments:

- Situation: Suppose there are 5 different algebra books, 6 different geometry books, and 8 different calculus books.
- Question: In how many ways can a person pick a pair of books if they must choose books on different subjects?
- *Gil’s solution:* Each algebra book can be paired with each Geometry book and each Calculus book. So, each algebra book can be paired with $6+8=14$ other

books. Since there are 5 algebra books and this is true for each algebra book, there are 5×14 total pairs with an Algebra book. Now, the Geometry books have already been paired with the Algebra books so we need to pair the Geometry books with the Calculus books. Each Geometry book can be paired with 8 Calculus books. Since there are 6 Geometry books, there are a total of 6×8 pairs consisting of Geometry and Calculus books. Since all of the books have now been paired together, we have a total of $5 \times 14 + 6 \times 8$ pairs of books.

Polly's solution: We have three different cases based on the types of books chosen: We can either have an Algebra book and a Geometry book, an Algebra book and a Calculus book, or a Geometry book and a Calculus book. Each Algebra book can be paired with 6 Geometry books, so we have 5×6 pairs with Algebra and Geometry. Each Algebra book can be paired with 8 Calculus books, so we have 5×8 pairs with Algebra and Calculus. Finally, each Geometry book can be paired with 8 Calculus books, so we have 6×8 pairs with Algebra and Calculus. Altogether, we have $5 \times 6 + 5 \times 8 + 6 \times 8$ total pairs of books from different subjects.

Gil's and Polly's solutions are arguments driven by two qualitatively different ways of thinking which will be called *Addition* and *Union*, respectively (see Section 5.1 below for more information on these ways of thinking). The pair of arguments could be provided to students in order to raise awareness of each way of thinking and for contrasting by the students. As the students contrast the arguments, they might observe the subtle differences and would be less likely to classify these ways of thinking as the

“same thing.” By providing these arguments to the students, the instructor could orient the students to thinking about their ways of thinking.

2.4.1.2. Potentially Pivotal-Bridging Examples

According to Zazkis and Chernoff (2008), an example is a “*pivotal-bridging example*” for a student if working through the task pushes the student to re-evaluate their current conception or belief by either raising or resolving cognitive conflicts. The term “pivotal-bridging” comes from the fact that the example then serves as a bridge from the student’s initial, naïve conception to a more mathematically appropriate conception. An instructor is implementing a *Potentially Pivotal-Bridging Example* provocation if he or she introduces an example with the intention of having the example be a pivotal-bridging example for a student (Roh & Halani, 2011). In other words, if an instructor introduced an example with the intention that the student use the example to change his or her current conception or belief, the instructor is said to be implementing Potentially Pivotal-Bridging Examples.

For example, a student might claim that there are $2n$ permutations of n distinct elements, reasoning based on the number of permutations of 3 distinct elements. The instructor could then suggest a counter-example to the students’ conception: the number of permutations of 2 distinct elements. If the student reasons that since a counter-example exists to his or her claim, the student must revise the claim, then the number of permutations of 2 distinct elements would be a pivotal-bridging example for the student. The number of permutations of 2 distinct elements is an example designed to provoke the student to change his or her conception and is therefore a Potentially Pivotal-Bridging Example.

2.4.1.3. Stimulating Questions

Stimulating Questions are delivered as the instructor asks questions or makes statements in order to push the students to test their current conception (Roh & Halani, 2011). The intention of the question or statement delivered through Stimulating Questions is to highlight inconsistencies in a student's reasoning so that the student recognizes his or her existing understanding or thinking is problematic. For example, a student might claim that there are 2 permutations of the letters A and B: AB and BA, because he could "move" A over to the other side of B to create the next permutation. The student might also claim that there are 6 permutations of the letters A B and C: ABC, ACB, BAC, BCA, CAB, CBA, because he could hold one letter constant at the front of his permutation and vary the other two letters and then change which letter is being held constant. If this is the case, the instructor might ask the student if he could apply the "moving one letter over" reasoning to the task of determining the number of permutations of 3 distinct elements. Here, the instructor is adapting the student's way of thinking to a different example. The student will ideally observe how his or her way of thinking might not apply to more general examples. The instructor's intention is to highlight inconsistencies in the student's reasoning, and he or she is therefore implementing Stimulating Questions. In this example, the student determined the correct number of permutations in each case; however, the instructor is focusing on the student's reasoning and bringing the student's attention to the inconsistencies.

2.4.1.4. Devil's Advocate

Devil's Advocate is an atypical argument provided to students by the instructor for evaluation (Halani et al., 2013). The idea is that instructor believes that the argument may

be atypical *to the student* who evaluates the argument. In fact, the argument may or may not be valid mathematically. However, regardless of its mathematical validity, the student might consider the argument to be atypical and would therefore create a source of potential perturbation. The purpose of this type of provocation is to highlight cognitive conflicts or raise awareness of certain aspects of a topic.

After evaluating the argument, the students would either refute the argument or provide justification for portions of the argument. For example, a student might not be aware that it is possible to generate the set of permutations of n distinct items by holding one item constant in different places. If this is the case, the instructor might use Devil's Advocate by introducing a solution supposedly written by a former student generating the set of permutations of the letters A, B, and C in this manner:

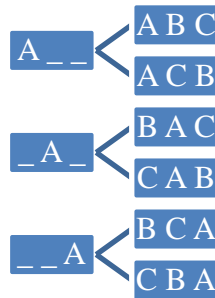

Figure 5. An example of Devil's Advocate

The student would then analyze this solution and determine if the reasoning applied is logical. If not, the student would refute the argument. If it is logical, the student would justify why this reasoning is appropriate for generating the solution set of permutations of 3 distinct items, and perhaps extend this argument to generating the solution set of permutations of n distinct elements. In this way, the instructor is raising

awareness of a particular relationship between elements of the solution set through an atypical solution.

In this study, Potentially Pivotal-Bridging Examples were used to order the tasks. Stimulating Questions were used to draw a student's attention to inconsistencies in his or her reasoning, and Devil's Advocate and Contrasting Prompts were used to present alternate solutions or arguments for many of the tasks. The arguments presented were often driven by ways of thinking that the student might not have encountered before in order to create sources of perturbation.

2.4.2. Pedagogical content tools

A *pedagogical content tool* (PCT) refers to “device, such as a graph, diagram, equation, or verbal statement, that a teacher intentionally uses to connect to student thinking while moving the mathematical agenda forward” (Rasmussen & Marrongelle, 2006, p. 389). Thus, it involves both the activity of a teacher attempting to make connections to student thinking as well as the device the instructor uses to do so. Graphs and diagrams, two of the devices Rasmussen and Marrongelle mentioned in the quote above describing PCTs, involve visual representations.

Conventional wisdom often advises students to use visual representations while they are solving novel problems. For example, Polya (1957) included “draw a picture or diagram” as one of his heuristics in *How To Solve It*. Further, Fischbein (1977) believed the coordination of conceptual schemes and intuitive representations to be essential for problem solving. Recently, the mathematics education community has demonstrated an increased interest in visualizations in mathematics, both in understanding students' visual

representations and in helping these students build their intuitive visual images in order to understand abstract concepts (Alcock & Simpson, 2004; Palais, 1999; Pinto & Tall, 2002; Roh, 2008, 2010; Tall, 1991).

In line with Fischbein (1977), *visual images* are “pictorial representations of conceptual entities and operations” (p. 154). They are conceptualized images, controlled by abstract meanings. In a sense, they constitute a language – their meanings are often fairly conventionalized and they can express a wide range of ideas by using a limited method of communication (Fischbein, 1977). In addition, *visualization* includes the processes of constructing and transforming visual mental images (Presmeg, 2006). Thus, we can refer to a student’s visualizations or visual images even if their representations are not physically drawn anywhere.

Given the importance of visual images in problem solving, it appears as if an important role an instructor could play in a classroom is to implement PCTs in order to introduce students to ways to represent their current ways of thinking. In particular, the instructor could help students relate their way of thinking with a visual image, thus advancing the mathematical agenda. One way these PCTs could be implemented is through instructional provocations. Indeed, after a student solves a task by engaging in Equivalence Classes, an instructor could implement Devil’s Advocate by providing her with a mapping diagram for a solution driven by Equivalence Classes. The instructor could ask her to reinterpret the Devil’s Advocate in her own words. The instructor’s intention in doing so could be to help the student connect her Equivalence Classes thinking with the visual representation. Thus, the instructor would be using a PCT (the mapping diagram) implemented through Devil’s Advocate.

In this study, several visual representations were introduced to students through the Devil's Advocate instructional provocation. The intention in using such PCTs was to strengthen students' ways of thinking by encouraging the coordination of students' conceptual schemes with corresponding visual images.

3. LITERATURE REVIEW

Existing research in combinatorics education has focused on the following areas: combinatorial reasoning in children (English, 1991, 1993, 2005; Piaget & Inhelder, 1975; Shin & Steffe, 2009), a model for students' combinatorial thinking (Lockwood, 2010, 2011a), classification of combinatorial models (Batanero et al., 1997b; Dubois, 1984), and very specific aspects of the teaching and learning of combinatorics (Abromovich & Pieper, 1996; CadwalladerOlsker et al., 2011; Eizenberg & Zaslavsky, 2004; Fischbein & Grossman, 1997; Godino et al., 2005; Hadar & Hadass, 1981).

3.1. Combinatorial Reasoning in Children

Research in combinatorics education began with the experiments of Piaget and Inhelder (1975), focusing on the development of combinatorial reasoning in children. Through clinical interviews with children working on combination, permutation and arrangement problems, Piaget and Inhelder identified three basic stages of combinatorial development. English (1991, 1993) researched young children's strategies for problems involving arrangements of 2 or 3 items from 3 to 5 items, and Shin & Steffe (2009) identified the types of enumeration in which students engaged while solving combinatorial problems.

In general, Piaget and Inhelder (1975) reported three basic stages of combinatorial development in children:

- Stage I: Children use trial-and-error. For example, for a two card arrangement problem with three distinct cards, they might take any card, place it with any other one, and check to see if this pair is already listed.
- Stage II: Children begin to search for a system but do not arrive at an exhaustive solution. These students do have a sense of regularity, but it is empirical. For example, in the two card arrangement problem from 3 distinct cards, the student might see that their constructed arrangements can be ordered according to the first card in the arrangement. However, when asked to create arrangements from more than 3 cards, the student might struggle.
- Stage III: Children methodically list all possible solutions.

In their studies, Piaget and Inhelder (1975) found that the stages of combinatorial development roughly correspond to three of Piaget's four stages of cognitive development; none of the stages of combinatorial development corresponded with the sensorimotor stage. Stage I corresponds to the pre-operational stage of development which is characterized by sparse and logically inadequate mental operations and occurs between the ages of 2 through 7. Around age 7, children transition into the concrete operational stage which is characterized by the appropriate use of logic; this corresponds with Stage II of combinatorial reasoning. Finally, around age 11, children transition into the formal operational stage during which they begin to think abstractly and reason logically. This formal operational stage corresponds with Stage III of combinatorial reasoning. The reason Piaget and Inhelder conjectured that students were unable to truly discover a systematic manner of listing all possible outcomes before the formal

operational stage was because children do not have the ability to anticipate all possible outcomes before such a time. Indeed, in order to be at Stage III of combinatorial reasoning, students must have stable patterns in reasoning – they must have developed ways of thinking about tasks, not simply strategies for solving them. In line with Bjorklund (1990), this study refers to strategies as “goal-directed, mental operations that are aimed at solving a problem” (p. xi).

As reported in Fischbein (1975), Piaget and Inhelder performed a series of experiments on combinatorial operations with children: Four bottles labeled 1-4 contained colorless substances, and a fifth bottle contained drops of potassium iodide. If the first, third and fifth bottles were combined then a yellow-colored mixture was obtained. Children were asked to reproduce the yellow color, but only students at Stage III of combinatorial development were able to successfully find a systematic manner of doing so. According to English (1991) this is one example in which Piaget’s experiments were “too scientific” (p. 452) and abstract in their instructions to the child. Furthermore, a lack of familiarity with the objects in the task was cited as having an adverse effect. For these reasons, English (1991) maintained that Piaget seemed to underestimate young children’s abilities. In order to address whether Piaget & Inhelder actually did underestimate young children’s abilities, English (1991) used the task of dressing toy bears with tops and bottoms to demonstrate that children between the ages of 4-9 could discover a systematic procedure for dressing the bears prior to the stage of formal operations. Students were asked to make as many different outfits as they could from the given set of shirts and pants with different colors. Six solution strategies were revealed: (1) a random selection of items with no rejection of inappropriate items; (2) trial-and-

error; (3) emerging pattern in item selection, with rejection of inappropriate items; (4) consistent and complete cyclical pattern item selection, with rejection of inappropriate items; (5) emergence of an incomplete “odometer” strategy (children repeat the selection of an item until all possible combinations have been formed with that item; upon exhaustion with that item, a new item is chosen) in item selection, with possible item rejection; (6) complete odometer strategy in item selection, with no rejection of items (English, 1991).

English (1993) expanded her 1991 study with an extended set of tasks and students (7-12 years in this case). Here, the tasks progress from dressing bears with tops and pants, to dressing them with tops, pants, and tennis rackets. The solution strategies from English (1991) were observed for the 2-dimensional tasks and the “odometer” strategy was extended to the 3-dimensional case. In these problems, the students employing the “odometer” strategy must operate simultaneously with two constant items, called the major and minor items. The major constant items are called such because they are changed less frequently than the minor constant items since they are used repeatedly with each of the minor items.

English (1993) provided the following example: suppose the children were provided with 2 tops (labeled X_1, X_2 for ease), 3 pants (called Y_1, Y_2, Y_3), and 2 tennis racquets (called Z_1, Z_2). Then, the odometer strategy applied to these items could systematically match each of the X items with each of the Y items, and each of these, in turn, is matched with each of the Z items, as seen in Figure 6.

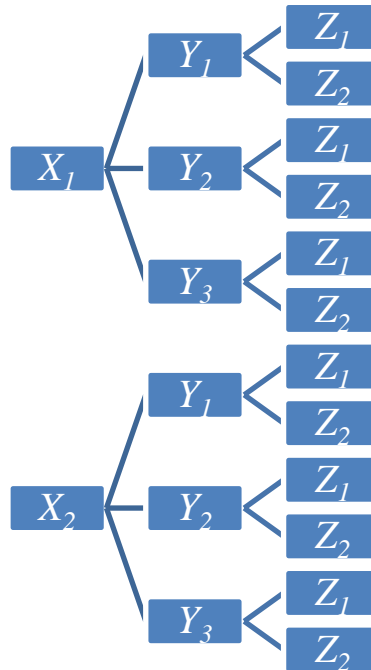

Figure 6. Reproduction of tree diagram for dressing bears from English (1993, p.147)

Five strategies were identified by English (1993) for dressing the bears with three items: (A) trial and error; (B) adoption of a pattern but failure to apply it throughout execution; (C) exhaustion of minor constant items but failure to exhaust a complete set of minor and major constant items; (D) exhaustion of a complete set of major and minor constant items but of only one set; (E) exhaustion of both sets of major and minor constant items.

English (1991, 1993) did show that students as young as 7 years old can use a systematic manner of listing all possible outcomes. However, her results are not necessarily contradictory to Piaget & Inhelder's (1975), as she claims. Indeed, the reason that Piaget & Inhelder believed that students did not enter Stage III until the formal operational stage is that they were not able to anticipate the possibilities before then

because they were not capable of hypothetical thought. Though English's (1991, 1993) students used a systematic manner of listing the elements, this system may have been constructed while they were operating. It is not clear from her report whether the system was available to the students prior to the dressing of the bears. As such, she has not truly shown that her young students were truly at Stage III of combinatorial development – there is no evidence that her students were able to *anticipate* that their approach would work or that they were able to construct the tree diagram as she did. Indeed, they may have been implementing a strategy directed at the goal of solving the problem, not engaging in a way of thinking.

Furthermore, English does not provide explanations for the operations used by the children even though “Piaget and Inhelder (1975) already mentioned that combinatorial operations should be rooted in additive juxtaposition and multiplicative association” (Shin & Steffe, 2009, p. 171). Steffe (1992) observed children's constructions of combinatorial operations and referred to them as *lexicographic units-coordinating operations*. *Units-coordination* is to “distribute a composite unit over the elements of another composite unit” (as cited in Shin & Steffe, 2009, p. 171). For example, if students are asked how many outfits might be made from 2 shirts and 3 pants, they must construct the units to be counted as the combination of one shirt and a pair of pants. The units-coordination operations required to make possible pairs is called *lexicographic* because of the dictionary ordering of the pairs. In the example with shirts and pants, the students might list the outfits with one shirt first, and then the outfits created with the other shirt. In this sense, Shin and Steffe (2009) described the operations employed by students implementing the Odometer strategy.

Shin and Steffe (2009) reported results from a year-long teaching experiment, during which two days were spent on combinatorics, with 2 middle school students – Carol and Damon. They found that the students performed three different types of enumeration: additive, multiplicative, and recursive multiplicative. A summary of their findings is below:

First, the students were presented with a window containing four sub-windows and asked to find how many ways there were to paint the four windows with two colors. Carol tried to pictorially represent the possibilities. Damon repeatedly wrote and erased the letters “R” and “B” in each sub-window, using tally marks to keep track of how many entries. Carol ended up with 14 possibilities and Damon with 15. Carol had randomly listed her possibilities, which indicates that she had engaged in additive enumeration, meaning that she attended to a unit being counted and executed the counting additively.

Carol and Damon were then asked “How many two digit numbers can you make?” Damon started by listing the numbers 10, 20, ..., 90 in a column and then writing 11, 21, ..., 91 in the next column and continued in this manner until he stopped. He originally wrote 81 as the solution, but, after the researcher instructed him to continue writing and to check his answer, he finished the columns and changed his answer to 90. Damon explained that the zero in the one-digit place could go with 9 numbers in the ten-digit place, as did the other numbers in the one-digit place. The fact that he constructed a table to complete his counting activity indicates a multiplicative structure. However, he was not able to anticipate the result of completing his table prior to actually writing down

all of the numbers. This indicates that his multiplicative structure was not fully available to him prior to operating.

Finally, Carol and Damon were asked to create different permutations of two distinct cards. They eventually moved up to a 5 distinct card permutation. For the 2-4 distinct card permutation problems, the students listed all possible units-coordinating operations of permutations. For the 5 card problem, both students arrived at 120, but were unable to explain their solutions. Damon tried to write all possible arrangements by fixing “1” for the first card, but seemed to lose track of what he was doing. When he was asked to explain his answer, “he said that he fixed the first two cards as ‘1’ and ‘2’ and counted all possible five-card arrangements with the fixed two numbers, which were six cases and then he got one hundred twenty by multiplying by four and five in order. However, Shin and Steffe stated that he could not provide a satisfactory justification for why he multiplied by four and five.

Damon and Carol both employed the odometer strategy discussed in English (1991). However, Shin and Steffe’s (2009) study focused not only on what the students *do*, but also on the students’ reasoning. For example, when discussing Damon’s solution to the 5-card permutation problem, Shin and Steffe noted that he was not able to provide a satisfactory justification for his final answer. Thus, it is clear that this recursive multiplicative structure was not available to Damon prior to his operating. His solution was a product of his operating. Based on the perspective adopted in this study, if the multiplicative structure was available to Damon prior to operating, then this would indicate that he is envisioning the structure of the problem and the relationship between

units being counted – a way of thinking about the problem. However, because Damon’s solution was a product of his operating, we can only say that his solution revealed a way of understanding about the problem.

Maher, Powell, and Uptegrove (2010) conducted a longitudinal study which explored how students’ reasoning evolved as they progressed through combinatorics tasks from elementary school, to high school, and eventually to college. The results from their study focused on students’ forms of reasoning (such as proof by cases, induction, contradiction, etc.) and how these ways of reasoning changed throughout the study, students’ intuitive use of representations (visual and notational) and the evolution of such representations over time, students’ acquisition of formal notation, students’ forging of conceptual connections between isomorphic problems, and so forth. Thus, though combinatorics was chosen as the context for their study, students’ combinatorial reasoning was not the focus of their study. Still, much can be learned from their results. For example, they found that representations were a source for helping students make connections between isomorphic problems and relating to Pascal’s Triangle, which led to increasingly advanced mathematical reasoning and justification. Thus, it appears as if using pedagogical content tools (Rasmussen & Marrongelle, 2006) (see 2.4.2 above) to introduce representations might help students develop their reasoning.

This study is not concerned with the development of combinatorial reasoning in children. However, much of relevance can be gathered from the works of Piaget, English, Shin, Steffe, and Maher et al. Primarily, developmental studies provide insight into what comprises combinatorial reasoning – students may use either trial-and-error, or search for, but fail to find or realize, a systematic manner for listing all possible outcomes to a

given task, or use a systematic manner. In the examples of students engaging in multiplicative and recursive multiplicative enumeration in Shin and Steffe (2009), it is clear that the students are trying to generate all possible outcomes of the problem in a systematic manner. However, the ways of thinking engaged in by the students are not clear from their study. In other words, the question remains of identifying the stable patterns of reasoning underlying the students' ways of understanding. This current research builds upon the work of Shin & Steffe, English, and Maher et al. by focusing on the ways of thinking students engage in while solving combinatorial problems.

3.2. A Model of Students' Combinatorial Thinking

Lockwood (2011a) identified two main perspectives of thinking about combinatorial problems: the *process-oriented perspective*, and the *set-oriented perspective*. In the process-oriented perspective, the act of counting amounts to completing a procedure which consists of individual stages. For example, a student might say that there are six 2-card arrangements without repetition of 3 distinct letters because they have 3 choices for the first letter in the first stage, 2 choices for the second letter in the second stage. The student would multiply 3 and 2 to get 6. The student may or may not associate this procedure with a set of outcomes. In the set-oriented perspective, the act of counting amounts to determining the cardinality of the set of objects being counted, known as the *solution set*. For the example of 2-card arrangements without repetition of 3 distinct letters (say, A B and C), the student might construct the solution set {BA, AB, CB, AC, BC, CA} and determine the cardinality of this set to be 6.

Lockwood (2010) demonstrated that having a notion of a solution set is important in counting. She claimed that without this notion, students tend to look for and use surface features of a problem and may also have difficulty using the knowledge they do have. In fact, Lockwood presented evidence from three case studies which show that even having a partial representation of a solution set, or envisioning a single element of a solution set, can be extremely beneficial to students as they solve the problem – those students with some representation of the solution set were better able to identify errors and arrive at a correct solution.

Lockwood (2011a) claimed that being able to coordinate processes and sets is important because though thinking in steps or stages is a necessary part of counting, it is sometimes vital to link the process with a set of outcomes. For example, Lockwood (2011a) included the following problem and solution:

Problem: A password consists of 8 upper-case letters (repetition is allowed). How many such 8-letter passwords contain at least 3 E's?

Solution: $\binom{8}{3} \cdot 26^5$

The solution is driven by the process of choosing 3 of the 8 letters in the password to be E's in the first stage, and then determining that there are 26 choices for each of the other 5 spaces in the second stage. In order to determine that the solution is incorrect, it can help to envision the element EAXESEJE of the solution set. This element is counted twice by the process. A student who realizes this error might instead engage in a case-by-

case analysis of the task, first counting the number of passwords that include 3 E's, then the number that include 4 E's, and so forth.

Further, Lockwood (2011a) presented a model of students' combinatorial thinking. There are three components to this model: sets of outcomes, counting processes, and formulas/expressions. The first component refers to the solution set, the second to the counting process discussed above in the process-oriented perspective, and the last refers to mathematical expressions which yield a numerical value. As mentioned above, the coordination of sets and processes is essential to counting.

In addition, Lockwood found that students can also coordinate processes with expressions. Indeed, the expression $\binom{8}{3} \binom{5}{2}$ could refer to the process of first choose 3 items from 8 items and then choosing 2 items from 5 items. In the opposite direction, a counting process could be associated with an expression – the process of permuting 10 distinct items corresponds to the expression $10!$. Though she did not find empirical data to support the claim, Lockwood conjectured that solution sets could be coordinated directly with expressions. Indeed, the expression $\binom{8}{2}$ could bring to mind 2-item subsets of 8 distinct items.

This current study is concerned with students' ways of thinking about combinatorics solution sets. From Lockwood's results, it appears as if ways of thinking that facilitate coordination between solution sets and counting processes could be

especially important. As discussed in Section 2.3.1.1 above, Generalized Odometer is a way of thinking which could encourage such coordination.

3.3. Classification of Combinatorial Models

Dubois (1984) classified simple combinatorial configurations into 3 main categories: 1) Selections – a set of m objects are considered from which a set of n objects must be selected. These original m objects may or may not be distinct and we may or may not allow repetition in our selection. 2) Distributions – a set of n objects must be distributed between m cells. Again, variations abound - the objects may or may not be distinct, the cells may or may not be distinct, order of placement of objects may be important, empty cells may be allowed, cells may only receive a maximum of some number of objects, etc. 3) Partitions – a set of n objects must be split into m subsets (Batanero et al., 1997b). It is important to note that splitting a set of n objects into m subsets can be viewed as distributing n objects into m cells so there is a bijective correspondence between the models of distributions and partitions. However, this relationship might not be clear to students.

Building on the work of Dubois, Batanero et al. (1997a) studied whether partition and distribution problems appeared the same to students. The language in which the problem was stated includes cues as to which model is implicit in the statement. Batanero et al. (1997a) defined the *Implicit Combinatorial Model* (ICM) as the model implicit in the statement of a simple combinatorial problem. For example, words such as “choose,” “select,” “take,” and “draw” indicate that the problem is a selection, whereas “place,” “introduce,” “assign,” and “store” would indicate a distribution, and “separate,” “divide,”

and “split” would indicate a partition (Batanero et al., 1997b). In order to examine the effect of the ICM on problem difficulty, they distributed questionnaires to 720 Spanish high school students, about half of which had received instruction in combinatorics. They found that there was no difference in the difficulty between the three types of models for students who had not had instruction in combinatorics. Students with instruction did better on selections, arrangements, permutations, permutations with repetition problems. Distribution problems still seemed difficult for many, and partition problems were troublesome for all. According to the authors, the Spanish combinatorics curriculum focuses mostly on sampling (selection) and occasionally on arrangements and permutations (distributions) – very little instruction uses the partition model. Batanero et al. noted the correlation between the amount of instruction using a particular model and students’ difficulty on problems with that ICM and claimed that the implicit combinatorial model is therefore a didactic variable.

Kavousian (2008) presents an alternate classification of problems: 1) Arrangements – order of the elements within the configuration does matter; 2) Selections – selection of elements within a configuration such that the order of the elements does not matter; 3) Partition – placement of n objects in m cells. She chose that classification for her study because of the clear distinction between the categories and because the language is similar to that used in North American textbooks.

It is the conjecture of this dissertations’ author that students may engage in different ways of thinking based on the classification structure as identified by Dubois (1984). It is possible that students will engage in one way of thinking about a problem

with Partition ICM and another way of thinking about the same problem with Distribution ICM. There is evidence in the research literature of students seeing isomorphic situations as being very different. For example, consider two ideas about division: *sharing* is the action of distributing an amount of something among recipients so that each one receives the same amount, and *segmenting* is the action of putting an amount into parts of equal size. The result of both sharing and segmenting an amount is determined by division. However, in order to see why the results are the same in either situation requires the ability to anticipate the result of acting prior to acting (P. W. Thompson & Saldanha, 2003), and there is evidence that students are not always immediately able to see the situations as isomorphic. Similarly, it is possible that students may view isomorphic problems with the distribution ICM and partitioning ICM in different manners as well. Thus, in order to elicit as many of students' ways of thinking as possible, this study included tasks with different ICM.

3.4. Literature with Narrow Foci

Some of the literature related to combinatorics education focuses on very specific aspects of the teaching and learning of combinatorics. Some provide practical advice on how to teach combinatorics (Abromovich & Pieper, 1996). Other recent research literature topics include specific mistakes students might make when solving a particular combinatorics problem (Hadar & Hadass, 1981) and which formulae and principles students use when solving specific counting problems (CadwalladerOlsker et al., 2011). Still other pieces of the body of research use combinatorics as the setting in which to study other things such as student verification strategies (Eizenberg & Zaslavsky, 2004), intuitions and schemata (Fischbein & Grossman, 1997), and an analysis of semiotics

(Godino et al., 2005). Though these pieces of research are not central to this study, they are included in this Section for completeness.

Abramovich and Pieper (1996) reported work done with preservice and inservice secondary teachers in which they stress the importance of developing conceptual understandings of permutations and combinations, providing examples of tasks designed to foster recursive thinking in students. However, they do not base their advice on an empirical study and, though they wish to encourage a particular way of thinking in students, they provide no evidence for the ways of thinking students actually engage in about combinatorics.

Hadar and Hadass (1981) discussed mistakes students might make while solving the Bernoulli-Euler problem of mis-addressed letters: “Someone writes n letters and writes the corresponding addresses on n envelopes; how many different ways are there of placing all the letters in the wrong envelopes?” The pitfalls the students encounter on this problem involve having trouble identifying the set of events, choosing appropriate notation, perceiving the problem as a set of distinct problems, constructing a systematic method of counting, fixing a variable, putting the counting plan into effect, and generalizing. They do not base their report on an empirical study and do not explain *why* the students might make those mistakes.

Eizenberg and Zaslavsky (2004) conducted a study aimed at identifying students’ tendencies to verify their solutions and the strategies for verification employed while solving combinatorial problems. The problems given to the students were designed so that a variety of principles and operations were required for its solution, fostering the

need to verify the solutions. Five categories of verification identified: 1) reworking the solution, this was frequently used but not very effective; 2) adding justifications to the solution, this was useful for detection of minor errors; 3) evaluating the reasonableness of the solution - this was not frequently used, however, it did prove helpful when the answer obtained was larger than the solution set; 4) modifying some component of the solution, which proved useful if the student uses the same strategy with smaller numbers; 5) using a different solution method and comparing answers, which was frequently used and helpful. Though students' initial solutions were mentioned, there is no discussion of how the students reached that solution, or the ways of thinking underlying such solution strategies.

Perhaps the reason that strategy 3 in Eizenberg and Zaslavky's (2004) study was not frequently used is because it can be difficult to estimate the size of a solution set. Fischbein and Schnarch's (1997) study indicated that intuitions are based on schemata (or a sequence of relatively flexible and adaptable steps, aimed to interpret a certain amount of information and prepare the corresponding reaction) and this hypothesis was checked in the context of combinatorics (Fischbein & Grossman, 1997). In their study, Fischbein and Grossman (1997) distributed to a questionnaire 255 people (7th graders, 9th graders, 11th graders, teachers' college students, other adults) who had never been in a combinatorics course. The participants were asked to estimate solutions to each problem. 25 participants were then interviewed and asked to explain their solutions. Fischbein and Grossman concluded that combinatorial intuitive guesses were based tacit computations reliant on combinatorial schema; in particular, the guesses are based on binary multiplicative operations (multiplicative operations involving two numbers such as

$2^4, 4^2, 2 \times 4$, etc.) and also adjusted based on intuitions about what should be the correct answer.

Godino et al. (2005) reported that many of the errors the students in their study made in their solutions stemmed from semiotic conflicts – differences between the students' interpretations of the problem and the mathematical institution's interpretation. For example, when solving a problem which involves distributing four different colored cars to 3 people, one student in the study insisted that the colors of the cars were superfluous data. To the student, the cars were therefore identical. To the mathematical institution, a black car is distinct from a blue car. Understanding students' interpretations of problems is therefore essential to understanding their ways of thinking.

Based on their interpretations of problems, students might make connections between problems. Lockwood (2011b) investigated these connections students make between problems through the lens of actor-oriented transfer (AOT). She defined traditional transfer and actor-oriented transfer in the same way as Lobato and Siebert (2002): *traditional transfer* refers to the application of knowledge from one situation to another, and *actor-oriented transfer* refers to how students see situations as similar. Three types of AOT emerged from her data analysis: 1) Elaborated vs. Unelaborated, 2) Conventional vs. Unconventional, and 3) Referent types. An *elaborated* connection occurs when students explicitly explore the similarity between two situations whereas an *unelaborated* one is a connection a student mentions in passing. *Conventional* AOT occurs when students find similarities between tasks the mathematics community would conventionally view as isomorphic, whereas *unconventional* AOT refers to when students make connections between situations a mathematician might not view as similar. By

examining elaborated responses, Lockwood found that students pay attention to unconventional aspects of problem situations. Finally, Lockwood characterized AOT by whether the students referred to a particular problem, a problem type (e.g. permutations with repetition), or techniques/strategies. She conjectured that these referents were hierarchical – students begin by referencing particular problems, which eventually come to stand for a problem type, and eventually reference the underlying technique used in that problem type. This current study is not focused on actor-oriented transfer, but the connections students make between various ways of thinking could provide insight into the second research question concerning the relationships between ways of thinking.

4. RESEARCH METHODOLOGY

This chapter describes the methodology used for investigating the research questions outlined in the Introduction. The design of the study and the methods analysis, which are shaped by the theories discussed in Chapter 2, are discussed below.

The purpose of this study was to create models of students' ways of thinking about the elements of solution sets of combinatorics problems, to create and identify sources of perturbation for the students, and to analyze the evolution of their ways of thinking as they resolve these perturbations. In addition, this study examined if a sequence of tasks and interventions would foster students' engagement in the Equivalence Classes and Generalized Odometer ways of thinking, which were described in the Theoretical Perspectives chapter. For these purposes, this study employed teaching experiment methodology (Steffe & Thompson, 2000). Four undergraduate students from a large southwestern university were chosen to participate in two teaching experiments conducted in Spring 2012. The two teaching experiments could be thought of as separate phases of the study and were not conducted concurrently.

Table 1 summarizes the schedule for research activities. Prior to the two phases of the study, Pilot Studies 1 and 2 were completed by Fall 2011. Fourteen undergraduate students participated in two individual hour-long sessions with the researcher during Pilot Study 1. This pilot study served to create an initial framework for analyzing students' ways of thinking. Pilot Study 2 engaged two undergraduate students in a teaching experiment which involved six paired sessions. The purpose of this second pilot study was to observe the evolution of students' ways of thinking through guided instruction

designed to encourage Equivalence Classes and Generalized Odometer thinking. Based on these observations, the initial framework for students' ways of thinking was revised, as were tasks and protocols for Phases 1 and 2.

Table 1. Schedule for research activities

Period	Activity	Method
Fall 2010 – Spring 2011	Pilot Study 1 - Teaching Interviews (14 participants)	Voluntary Sampling Video recording, synchronization with written work
Fall 2011	Pilot Study 2 - Teaching Experiment (2 participants)	Voluntary Sampling Video recording, synchronization with written work
January 15- 21, 2012	Initial Contact of Students	Voluntary Involvement with Consent Request Cooperation
February 2012	Phase 1 - Teaching Experiment (2 participants)	Voluntary Sampling Video recording, synchronization with written work, content log
March 2012	Retrospective Analysis of Phase 1 Revision of tasks and protocols	Review of content log, Revision of the initial framework from open coding
April 2012	Phase 2 - Teaching Experiment (2 participants)	Voluntary Sampling Video recording, synchronization with written work, Content log
Summer and Fall 2012	Retrospective Analysis of Phases 1 and 2	Full transcription and coding of data

All sessions of Phases 1 and 2 were separated by a couple of days to allow for ongoing analysis and revisions to the tasks planned for the next session based on this analysis. The researcher engaged in retrospective analysis of the data from the first phase of the study before conducting the second, so that the first phase could serve as a pilot study for the second. A detailed description of each of the activities for Spring 2012 and the method used to collect data is provided later in this chapter. In later chapters, the pilot

studies are referred to as “Pilot Study 1” and “Pilot Study 2,” while the two teaching experiments conducted in Spring 2012 are referred to as “this study.”

The first phase of this study was conducted in February 2012. This phase involved two students and consisted of five hour-long paired sessions along with three hour-long individual interviews with each student. The paired sessions involved the researcher as a teaching agent, the two students, and methods of recording the session and students’ work. The setting for the individual interviews was similar to that of the paired sessions, though only one student was present instead of two and the researcher played the role of interviewer for some portions and teaching agent for others. After the retrospective analysis of Phase 1, the second phase of the study was conducted in April 2012. The two students in the second phase participated in one paired session together; one participated in eight additional individual interviews and the other participated in seven. The two students who participated in Phase 1 and one of the two students in Phase 2 completed all tasks designed for each teaching experiment, whereas the second student in Phase 2 only completed about half of the intended tasks. The remainder of this dissertation focuses on the data from the students who completed all of the tasks.

The goal of this study was to create models of students’ ways of thinking about the elements of the solution set, to create and identify sources of perturbation for the students, and to analyze the evolution of their ways of thinking as they resolved these perturbations. Steffe and Thompson (2000) describe teaching experiments as a research methodology for building models of students’ ways of thinking about specific mathematical ideas and examining how those ways of thinking develop in the context of instruction. Teaching experiments are designed for the generation and testing of

hypotheses about students' ways of thinking continually throughout the experiment. This methodology was chosen for this study as it was appropriate for addressing the research questions. Indeed, in order to address the first and third research questions in Chapter 1 above, the researcher had to develop models of students' ways of thinking about elements of solution sets and how these ways of thinking evolve. In addition, the fourth research question involved investigating in what ways an instructor might perturb students in order to provoke them into further developing their reasoning. This required the researcher to continually generate and test hypotheses about students' ways of thinking throughout the study.

4.1. Members of the Teaching Experiment

In line with Steffe and Thompson (2000), the teaching experiment aspects of this research involved students, a teaching agent, and a person outside of the interaction between the students and the teaching agent. This Section describes these members of the teaching experiment.

4.1.1. Students

During the first week of the spring semester in 2012, the researcher asked students in her own MAT 266: Calculus II for Engineers class if they would like to participate in her study. Six students contacted the researcher to express their interest and she informally met with the students individually to get a sense of the students' mathematical background. Students with prior formal experience with combinatorics, probability, or statistics were to be excluded from the study, however none of the students who approached her had this background. Two students were not willing to devote the time to participate in this study. A total of four students were selected to participate in the study –

two for each phase. The two students in the first phase, Kate and Boris (these are pseudonyms), participated in three individual interviews and five sessions as a pair. The two students in the second phase, Al and Steve (these are pseudonyms), participated in one session as a pair along with seven or eight individual interviews.

4.1.2. Teaching agent

The researcher served as the teaching agent. During each individual or paired session for teaching, the researcher engaged the student(s) in a task or series of tasks. Each task was separated into a situation and a question (or questions). For each task, the researcher presented the situation and asked the students questions about their interpretation of the situation so that she could understand the problem as the students saw it. Once the researcher had created a model of situation as the students saw it, she presented the students with the question and asked them to solve it.

As each session developed, the researcher attempted to create on-the-spot models of students' mathematics. She theorized about the ways of thinking in which students might be engaging. Based on these models, the researcher asked the students questions in order to test the viability of the models. Also based on these models, the researcher sometimes implemented instructional provocations to gauge students' understanding of other ways of thinking about the problem. This is part of the "teaching" aspect of the teaching experiment. However, it was not the intention of the researcher to push students to simply finish the task or to transmit information to students. Instead, the goal of the researcher was to build and test models of students' mathematics. The purpose of the introduction of new ways of thinking about the problem was to gain more insight into the students' mathematics. Indeed, if the students were able to easily solve the problem

following the introduction of the new way of thinking or if the difficulties that the students were experiencing changed, then the researcher had more information about the students' mathematics. If the nature of the students' difficulties remained the same, then the researcher also had more information about the students' mathematics – namely that the students' ways of thinking about the problem were remarkably different from the proposed way – and knew that she needed to revise her models.

Following each session, the researcher asked the students to reflect aloud on, and discuss, the ways of thinking they engaged in during each task of the session. The purpose of this discussion with the students was to make explicit the ways of thinking involved in the tasks. The researcher therefore had another chance to confirm the viability of her models and to probe further the ways of thinking the students had discussed.

4.1.3. Outside perspective

The methodology of a teaching experiment as discussed by Steffe and Thompson (2000) calls for a witness of a teaching experiment. A teaching agent in a teaching experiment encounters a certain difficulty when inevitably working with a student who engages in apparently novel ways of thinking or makes mistakes and becomes unable to operate. Because she is immersed in an interaction, it is difficult for the teaching agent to step out of the interaction, reflect on it, and take action based on that reflection. She would have to be in two places at once – in the interaction, and outside of it. For this reason, it can be helpful to have an outside perspective for each session. A person who is always on the outside of the interactions in a teaching experiment can challenge the teaching agent's model of the students' mathematics.

In this study, a witness was not present during the teaching sessions. However, a mathematics education researcher provided an outside perspective during each phase. The researcher shared the written work of the students synchronized with their voices with the outside researcher for each session and then met with her for a debriefing session over Skype in between sessions. These meetings with the outside researcher were devoted to discussing the actions of the researcher and students during the previous session along with interpretations of those actions, and to planning the next session based on these interpretations.

4.2. Structure of the Designed Study

This Section describes how the study was intended to be implemented. It includes the description of the basic structure of each intended phase before elaborating upon the intended use of individual and paired sessions.

The teaching experiment was to consist of two phases, each of which was comprised of individual interviews and paired sessions. Each phase was to begin with an individual interview (II1), followed by two paired sessions (PS1 and PS2), a second individual interview (II2), and three more paired sessions (PS3, PS4, PS5). An exit interview (II3) was to be conducted at the end of the phase. Figure 7 shows the structure of the designed study. Following the top lines shows the sessions in which the first student would participate, and the bottom lines show the trajectory of the second student.

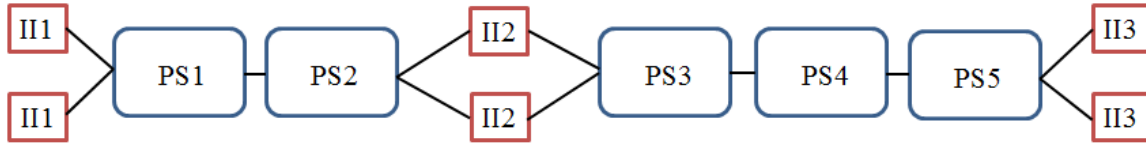

Figure 7. Structure of designed study

4.2.1. Individual interviews

The purpose of the interviews was for the researcher to attend to and deeply explore each individual student's ways of thinking at particular points in time. Three individual interviews were to be conducted during each phase – one at the beginning, one near the middle of the phase, and the third at the end. Both clinical interview (Clement, 2000) and exploratory teaching interview (Steffe & Thompson, 2000) styles were implemented during the individual interviews.

Of the 31 tasks implemented in this study, Tasks 1, 16, and 31 (see Appendix A) were chosen to serve as a pre-test, mid-study test, and post-test, respectively. In order for them to serve as such, it was essential that the researcher observe the students' ways of thinking at those particular moments. Since clinical interviews are designed so that researchers might observe students' ways of thinking at a particular moment in time (Clement, 2000), this method was chosen for these tasks. During these portions of the interviews, the researcher did not attempt to guide the students to develop new ways of thinking, provoke them into developing their reasoning, or intervene in any way. She asked questions only to clarify the students' statements and better understand their ways of thinking.

Exploratory teaching interview style (Steffe & Thompson, 2000) was implemented for the remaining tasks in the individual interviews. This style of interview method was chosen so that the researcher could become acquainted with students' ways and means of operating in the domain of combinatorics. In addition, it was chosen so that she could investigate how those ways of thinking develop in the context of instruction. During the exploratory teaching interviews, the students were to be provided with a situation for each task. After discussing the situation, he or she would work on solving a combinatorics question (or series of questions one at a time) associated with that situation. The student would be asked to explain his or her thought process. If the student could not solve the question, the researcher was to intervene with the student. For instance, the researcher could implement Stimulating Questions with the hope that the student would recognize inconsistencies in their reasoning or could implement Devil's Advocate to present a solution to the task. In the latter case, the student would evaluate the validity of the new argument, either providing justification for the argument or refuting it. In this way, the researcher would gain knowledge about how the way of thinking driving the Devil's Advocate fit in with the student's current conception. In addition, these Devil's Advocates might cause perturbation for the student who might then further develop his or her current way of thinking or make an accommodation for new ways of thinking.

4.2.1.1. Individual Interview 1

The first task (Task 1: Mississippi I, see Appendix A) in Individual Interview 1 was supposed to serve as a pre-test so as to gain insight into the students' initial ways of thinking. The other tasks (Tasks 2 - 5, see Appendix A) in Individual Interview 1 were to

be conducted in teaching experiment style, meaning that the researcher would implement interventions, and ask stimulating questions in order to probe students' ways of thinking and encourage students to develop sophisticated ways of thinking.

4.2.1.2. Individual Interview 2

Based on the results of Pilot Study 1, it was anticipated that students would experience a great amount of perturbation as they worked through Task 18: Table, where they solve what is colloquially known as a "circle permutation" problem. This problem involves seating n people around a large, circular table. In order to deeply explore the challenges students experience in this task, the researcher would conduct Individual Interview 2. Task 16: Sororities, the first task of the interview, was to serve as a mid-study test so that the researcher could observe the student's use of the ways of thinking developed during the first two paired sessions. The rest of this interview (Tasks 17: Perms in general and Task 18: Table, see Appendix) were designed so that the researcher might explore how the student's ways of thinking changed as he or she developed the operation of permutations and extends it to circle permutations.

4.2.1.3. Individual Interview 3

An exit interview was to be conducted at the end of the phase to observe students' final ways of thinking. This interview was to be conducted in a clinical interview style and to consist of a single task (Task 31: Mississippi II, see Appendix A) involving multiple questions. The first question in Task 31 is a variation of Task 1: Mississippi I. The other questions in the task are similar to questions used throughout the study. This was to serve as a post-test.

4.2.2. Paired sessions

Five paired teaching sessions were to be conducted during each phase. There were to be two paired sessions following the first interview and three after the second interview. Each paired session was to involve two students.

The rationale for involving two students in the teaching sessions was two-fold: First, the ways of thinking that each student engages in were to be investigated. If too many students were involved in a group study, then it may be difficult for the students to express their ways of thinking. Furthermore, it would be difficult from an analytical standpoint for a researcher to attend to each student's ways of thinking and build on these ways of thinking if many students involved. Second, it is possible for other students and the instructor to influence students' reasoning in a classroom setting. Indeed, it is known that social interaction can serve as a catalyst for students to construct knowledge (Cobb, 2007). Therefore, for the purposes of simulating a minimalist classroom, more than one student was to participate in the paired sessions for each phase.

The structure of the paired sessions was to be similar to that of the exploratory teaching style of the individual interviews. The pair of students was to meet with the researcher and work through a series of tasks. In these sessions, the students would be provided with a situation and given about 30 seconds to examine it individually. Then, in turns, they were to discuss their interpretations of the situation. After reaching a consensus about the situation, the students were to examine a question. Once again, they should spend a few seconds thinking about the question individually and then share their solutions with each other. If the students could not complete a problem, they were to be guided towards identifying inconsistencies in their reasoning through the researcher's use

of Stimulating Questions. When students presented arguments that differed, they were to be asked to re-interpret each other's arguments. By doing so, it was hoped that they would be provoked into considering an argument which was not their own and might thus further develop their reasoning. Similarly, Devil's Advocate was to be used to present alternate solutions to the students which they would then contrast with their own solution so that the two solutions could then serve as Contrasting Prompts. The hope was that as students overcame these perturbations, they would develop more sophisticated ways of thinking.

4.3. Implementation of the Designed Study

During Phase 1, the study was implemented as designed. The two students, Kate and Boris, participated in three individual interviews and five paired sessions as planned. The second phase, however, required modifications. During Phase 2, both Al and Steve completed the first individual interview. They also both participated in one paired session together. In this session, the students did not appear to work well together. Al would often solve a problem at a much quicker pace than Steve would. Steve, in turn, would quickly agree with Al's conclusions, though he had trouble articulating the conclusions in his own words. In addition, Al appeared to experience difficulties when attempting to explain Steve's problem-solving approaches, seemingly becoming frustrated with the slow pace of the session. Due to the dynamic of the pair, the researcher had difficulty ascertaining Steve's initial approaches to each problem. The purpose of having paired sessions was to simulate a minimalist classroom where interaction between students could serve as a catalyst for individual mathematical development. As this purpose was not being fulfilled during Phase 2, it was decided that it would be best to separate the two

students for the remainder of the phase. Al completed seven additional individual interviews with the interviewer and Steve completed six additional individual interviews. Steve only completed 13 of the 31 tasks designed for this study. As a result, he is excluded from the discussions in the rest of this chapter and in the remaining chapters.

The implementation of the tasks for Al during the seven additional interviews was similar to the implementation of the tasks in Phase 1, except that Al was unable to discuss his solutions with a partner. As planned, Task 16: Sororities and Task 31: Mississippi II served as mid-study and post-study tests, respectively, for Al, and these tasks were conducted using clinical interview style (Clement, 2000). The remainder of the tasks for Al were conducted using exploratory teaching style (Steffe & Thompson, 2000), as planned.

4.3.1. Data sources

Each session with students was videotaped. The students did all of their work using a SmartPen, which records everything written and synchronizes the writing with an audio-recording. In addition, the debriefing sessions with the mathematics education researcher who provided an outside perspective were recorded with the SmartPen.

Following each interview and paired session, the students were asked to complete written reflections. In their reflections, the students were asked to describe the tasks they encountered, their ways of thinking about the tasks and their solutions. They were also asked to describe any challenges they encountered, what they found to be most interesting, how they viewed the researcher's teaching, and any familiarity they might

have had with the topic discussed in that session. The reflection form can be found in the Appendix E. This served as an additional data source.

4.3.2. Order of the sessions

In Phase 1, the first individual interview was followed by two paired sessions, and second individual interview, three more paired sessions, and a final individual interview. As discussed above, this dissertation focuses on the students who completed all of the tasks and so the sessions for Phase 2 focus on the ones in which Al participated: the first individual interview, the first paired session, and seven more additional sessions (called Sessions 3-9). Table 2 shows the order of the sessions conducted in each phase, though the individual interviews in Phase 1 were conducted on the same day.

Table 2. Names and participants of the sessions in each phase

Phase 1		Phase 2	
Session	Name	Session	Name
Individual Interview 1 – Kate	P1_II1_K	Individual Interview 1 – Al	P2_II1
Individual Interview 1 – Boris	P1_II1_B	Paired Session 1 – Al & Steve	P2_PS1
Paired Session 1 – Kate & Boris	P1_PS1	Session 3 – Al	P2_S3
Paired Session 2 – Kate & Boris	P1_PS2	Session 4 – Al	P2_S4
Individual Interview 2 – Kate	P1_II2_K	Session 5 – Al	P2_S5
Individual Interview 2 – Boris	P1_II2_B	Session 6 – Al	P2_S6
Paired Session 3 – Kate & Boris	P1_PS3	Session 7 – Al	P2_S7
Paired Session 4 – Kate & Boris	P1_PS4	Session 8 – Al	P2_S8
Paired Session 5 – Kate & Boris	P1_PS5	Session 9 – Al	P2_S9
Individual Interview 3 – Kate	P1_II3_K		
Individual Interview 3 – Boris	P1_II3_B		

In the following Sections and chapters, some notation in Table 2 for the sessions will be used to refer to them. Table 2 also includes the name that will be used to refer to each session. In each name, the first two letters denote the phase: “P1” stands for Phase 1 and “P2” indicates that the session was in Phase 2. After the underscore is the name of

the session “II” stands for Individual Interview, “PS” stands for Paired Session, and “S” in Phase 2 simply stands for Session. The number indicates which interview or session the name refers to, and in the case of the interviews from Phase 1, the final letter indicates which student participated in that particular one.

4.4. Tasks

This Section provides an overview of the tasks and a general protocol that was to be followed during the sessions of the interviews and paired sessions. A full set of the 31 tasks and protocols for this study are in Appendix A. In that appendix, the statement of each task, the purpose of the task in the study, a protocol for that task, and any possible Devil’s Advocates which would be implemented are provided. In this chapter, a general protocol to be implemented for each task is described. Then, a brief description of some of the critical tasks implemented in this study is provided.

4.4.1. General protocol

As evidenced by the actions of students in Pilot Study 1 (Halani, 2012b), when presented with a mathematical question, students often begin to solve the question immediately. When this happens, it can be difficult for a researcher to see how the students are envisioning the situation. In addition, it is known that students do not always interpret combinatorial tasks in the same manner that the mathematical community does (Godino et al., 2005). Because it is essential that the researcher builds a model of the mathematical problem the student is working with, each task for this study involves both a situation and a question, and students were asked to evaluate the situation independently of the question. So that the researcher could gain some insight into students’ mathematics, the tasks are written with the intention that the students would

have some difficulties with the problem and that the nature of these problems would reveal information about the students' mathematics. The tasks were chosen to push the students to develop or extend certain ways of thinking which would build upon each other. These ways of thinking were identified in the preliminary framework developed during the pilot studies.

In this study, it was intended that as students participated in the teaching sessions, they would develop two particular ways of thinking, called *Equivalence Classes* thinking and *Generalized Odometer* thinking in this dissertation. As discussed in Chapter 2 above, Equivalence Classes involves creating a new problem and finding a multiplicative relationship between the sizes of the solution set to the new problem and the original problem. In particular, students engaging in this way of thinking would determine a bijective relationship between blocks of the same size in the new solution set and single elements in the original solution set. In Pilot Study 1, it was observed that students struggled to develop Equivalence Classes thinking, which inhibited their ability to find the size of the solution set to problems involving the combinatorial operation of permutations with repetition. Further, as found in Pilot Study 2, many problems with these permutations with repetition were also solved using the Generalized Odometer way of thinking, which involves holding a set of items constant, systematically varying the other items, and then changing the position for the first set. It appears as if this way of thinking coordinates the set-oriented and process-oriented perspectives on counting (Lockwood, 2011a).

Batanero et al. (1997b) claimed that the Implicit Combinatorial Model (ICM) had an effect on students' ability to solve a combinatorial problem. Therefore, many tasks in

this study were chosen because they involve the same combinatorial operations as other problems but different ICM. Students had opportunities for assimilation where they could deepen their ways of thinking by applying them in different types of situations.

In general, each task began with the researcher, as the interviewer or teaching agent, presenting a situation to the student or students. After considering the situation for a few moments, the students would then be asked to share what they envisioned about the situation. The researcher would ask clarifying questions about their responses and then present the question or questions one at a time. In the paired sessions, the students were given a few moments to think on their own and then shared their ideas with each other. In the individual interviews, the students worked on their own. The researcher asked clarifying questions to probe the students' actions, ways of understanding or ways of thinking. During the exploratory teaching portions, she intervened only if the students were stuck or once they had found a solution to the given problem. In the first case, she would use Stimulating Questions to help the students find their error or conflicting assumptions. Often, once they had completed the task, she implemented pre-designed Devil's Advocates and asked students to evaluate an alternate argument. The purpose of these Devil's Advocates was to either address potential student misconceptions, to introduce a new idea and gauge students' understanding of such an idea, or to highlight strategic knowledge.

As mentioned in 4.3 above, the implementation of the tasks and protocols during Phase 1 went as planned. The implementation during Phase 2 was similar, with three exceptions: 1) AI in Phase 2 participated in most sessions individually, 2) the order of the tasks in Phase 2 was slightly different as will be shown below in Table 3, and 3) an

additional intervention was implemented in Phase 2. The reason for 3) was that the students in Phase 1 and in the pilot studies would often over count the size of solution sets. During the retrospective analysis conducted between the phases, the researcher realized that this error could stem from an inability to visualize the set of elements under consideration. As a result, the Venn Diagram Activity was designed and Task 14: Letters abcdef was revised for Phase 2 so that AI would be introduced to Venn diagrams involving two and three sets. More details regarding this intervention are included in Section 5.3.1 below.

4.4.2. Overview of tasks

This Section describes the tasks conducted in each session of this study, discusses the combinatorial operations implemented in groups of tasks, and highlights some of the critical tasks implemented in this study. These tasks are the ones that were conducted in clinical interview style, or which were important in the development of students' ways of thinking because the implementation of the task caused perturbation for the students. The full set of tasks and protocols is included in Appendix A.

Table 3 shows the sessions for each phase, the tasks completed in each session, and whether the task was implemented in clinical interview style (CI) or exploratory teaching (ET) style, or assigned as homework (HW) for the student to complete in his reflection. In this table, the full name for each session is not included. For example, since the table is organized by phase, the P1 or P2 at the beginning of each session name was not included. In addition, since Kate and Boris completed the same tasks in the individual interviews in Phase 1, those were not separated by student. By looking under Phase 1, one can see that Task 16 during Individual Interview 2 (denoted II2) was conducted in

clinical interview style for both Boris and Kate. Because this research focused on the students who completed all of the tasks, the sessions for Phase 2 only included the tasks that Al completed. As such, one can see that in session 4 (denoted S4), Al was assigned task 15 as homework.

Table 3. Sessions and tasks for each phase

Phase 1					Phase 2				
Session	Tasks	CI	ET	HW	Session	Tasks	CI	ET	HW
II1	1	o			II1	1	o		
	2-5		o			2, 4		o	
PS1	6-10		o			3			o
PS2	11-15		o		PS1	5-6		o	
II2	16	o			7				o
	17-18		o		S3	7-10		o	
PS3	19-22		o		S4	11-14iv		o	
PS4	23-26		o		15				o
PS5	27-30		o		S5	14v-vi, 17, 18		o	
II3	31	o			S6	16	o		
					19-22			o	
					S7	22-26		o	
					S8	27-30			
					S9	31	o		

For groups of tasks (grouped by sessions in the designed study), the combinatorial operations associated with the tasks are shown in Table 4, which is designed to be read with Table 3. In this table, “A” stands for Arrangement, “AR” for Arrangement with Repetition, “P” for Permutation, “CP” for Circle Permutation, “C” for Combination, and “PR” for Permutation with Repetition. One might gain a sense of the progression of difficulty for the tasks throughout the study by examining Table 4 in conjunction with Appendix A. With the exception of tasks 14-18 in Phase 2, the tasks were administered in numerical order.

Table 4. Tasks and combinatorial operations

Tasks	A	AR	P	CP	C	PR
1-5	o					o
6-10	o	o				
11-15	o	o	o			
16-18	o	o	o	o		
19-22			o	o	o	
23-26					o	o
27-30	o	o	o		o	o
31	o	o	o		o	o

Many tasks in this study, in particular those implemented in the exploratory teaching sessions, were chosen in order to encourage student assimilation of ways of thinking. They were designed so that students would hopefully engage in one of their current ways of thinking while encountering slight variations on tasks. For example, when they engaged in a way of thinking for a problem involving an arrangement operation, it was hoped they would engage in the same way of thinking for a similar task involving arrangement with repetition. Tasks with different implicit combinatorial models were also included to encourage student assimilation. Below, some of the critical tasks are discussed in more detail.

4.4.2.1. Task 1: Mississippi I

The first task was conducted in a clinical interview style (Clement, 2000) so that the researcher could observe the student's initial ways of thinking about permutations with repeated elements. The statement of Task 1: Mississippi I is follows:

- Situation: Imagine that the state of Mississippi is adopting new, 11-character license plates. For fun, the state agreed to provide citizen who uses the letters

in the word “MISSISSIPPI” arranged in any order with a special license plate with an image of the mockingbird (the Mississippi state bird) as the background.

- Question: How many of these special license plates with the mockingbird must the state be prepared to create?

This task was chosen to assess students’ initial ways of thinking about permutations with repeated elements. It was not expected that students would be able to complete this task. Instead, the researcher intended to attend to whether students initially had the ideas of posing a new problem or holding items constant as they searched for an answer. The students encountered a version of this problem later in Task 31(i): Mississippi II. As a result, Task 1 served as a pre-test of sorts. In addition, it allowed the researcher to introduce the concept of combinatorics in a real-world situation.

4.4.2.2. Task 2: Dice

This task is a more traditional start to combinatorics problems than Task 1 was. The statement for Task 2 is below:

- Situation: Two dice are rolled, one white and one red.
- Question: How many outcomes are there that are not doubles?

This is a simple two-item arrangement problem. Such a task is easily accessible to students at all levels. Indeed, students could hold one die constant and vary the other, pose a new problem involving the total number of outcomes, or even physically list out all of the elements of the solution set. The tasks following this one increased in complexity by employing larger solution sets, different ICMs, and more items.

4.4.2.3. Task 16: Sororities

This task was designed to be conducted in clinical interview style (Clement, 2000) and to serve as a mid-study test. The statement for Task 16 is below:

- Situation: A university decides that sorority names can be three-letters chosen from the following Greek letters: $\Gamma, \Delta, \Theta, \Lambda, \Pi, \Phi, \Psi, \Omega$
- Questions: How many sorority names can be formed from these letters if
 - i. Repetition of letters is not allowed and either the letter “ Φ ” or the letter “ Γ ” must be used, but not both.
 - ii. Repetition of letters is allowed
 - iii. Repetition of letters is allowed and the letter “ Θ ” must be used.

Students would have encountered similar problems (e.g. Task 14: Letters abcdef) in previous sessions. During Phase 1, the students were paired in two of the previous sessions. In addition, in both phases, the researcher often implemented instructional provocations in the previous sessions. This task was designed so that the researcher could observe how the students worked as they solved the task on their own, without help from a partner and without any interventions from the researcher. As a result, Task 16 served as a mid-study test.

4.4.2.4. Task 18: Table

This task involved placing n people around a circular table, therefore intending to introduce students to circle permutations. The statement of Task 18 is below:

- Situation: A bunch of people would like to sit around a large, round table. It doesn't matter to them which particular seat they sit in, but they do care about the people who will be sitting to either side of them.
- Question: In how many ways can n people sit around a circular table?

This task is a Potentially Pivotal-Bridging Example in the sense that one of the Devil's Advocate arguments given at the end of the task was driven by the Equivalence Classes way of thinking. Equivalence Classes thinking is the first of the two ways of thinking this study is designed to encourage students to develop; and it is extremely important in developing the operations of combinations and permutations with repetition in the manner this study employed (see 4.4.2.5). As a result, it was essential that the researcher was able to closely attend to the development of each individual student's ways of thinking.

In both phases, the students worked through this task individually (during II2 in Phase 1 and during S5 in Phase 2). The Devil's Advocate driven by Equivalence Classes was presented as a former student's scratch work for the problem and was split into stages. This argument was designed in this manner and implemented in individual interviews so that the researcher could observe each student's initial ways of thinking as they attempted to understand Equivalence Classes thinking. Tasks 19-21 were designed to help students gain familiarity with permutations and to assimilate Equivalence Classes by engaging in this way of thinking for other tasks.

4.4.2.5. Task 22: Smoothie

This task was designed to introduce the operation of combinations to the students. It was hoped that students would use arrangements to develop the operation of combinations by engaging in Equivalence Classes. The statement of the task is below:

- Situation: Mario has a bunch of different types of fruit to put into his smoothie.
- Questions:
 - i. In how many ways can Mario make a smoothie with 2 types of fruit if he has n types of fruit to choose from?
 - ii. In how many ways can Mario make a smoothie with 3 types of fruit if he has n types of fruit to choose from?
 - iii. In how many ways can Mario make a smoothie with 4 types of fruit if he has n types of fruit to choose from?
 - iv. In how many ways can Mario make a smoothie with k types of fruit if he has n types of fruit to choose from?

In this task, students would build up from 2-element subsets of n elements to k -element subsets. A Devil's Advocate was designed which showed that there were 10 three-fruit smoothies that could be formed from five possible fruits. This was split into two possible stages – one which simply gave the numerical answer, and the other which involved factorials and division. Both are shown below (J1 and J2).

J1: $n=5$ types of fruit, 3 fruits in smoothie. There are 10 smoothies.

ABC	ACB	BAC	BCA	CAB	CBA
ABD	ADB	BAD	BDA	DAB	DBA
ABE	AEB	BAE	BEA	EAB	EBA
ACD	ADC	CAD	CDA	DAC	DCA
ACE	AEC	CAE	CEA	EAC	ECA
ADE	AED	DAE	DEA	EAD	EDA
BCD	BDC	CBD	CDB	DBC	DCB
BCE	BEC	CBE	CEB	EBC	ECB
BDE	BED	DBE	DEB	EBD	EDB
CDE	CED	DCE	DEC	ECD	EDC

J2: Let's see how this works for $n=5$. We know that the number of ways to order 3 fruits from 5 fruits is $5 \times 4 \times 3$. Now consider ABC. This has the same fruits as ACB, BAC, BCA, CAB, and CBA, and all of these will therefore create the same smoothie. In fact, this is true for each order of the fruit we found. We can organize the table as it is below. Since the number of ways to order 3 things is $3!$, we have $3!$ things in each row which will create the same smoothie. This means that we will have $\frac{5 \times 4 \times 3}{3!}$ ways to create a smoothie with 3 types of fruit when we have 5 types of fruit to choose from.

ABC	ACB	BAC	BCA	CAB	CBA
ABD	ADB	BAD	BDA	DAB	DBA
ABE	AEB	BAE	BEA	EAB	EBA
ACD	ADC	CAD	CDA	DAC	DCA
ACE	AEC	CAE	CEA	EAC	ECA
ADE	AED	DAE	DEA	EAD	EDA
BCD	BDC	CBD	CDB	DBC	DCB
BCE	BEC	CBE	CEB	EBC	ECB
BDE	BED	DBE	DEB	EBD	EDB
CDE	CED	DCE	DEC	ECD	EDC

After the completion of this task, the notation for combinations was given, but the explicit formula $\binom{n}{k} = \frac{n!}{k!(n-k)!}$ was not. In the tasks following, students were not required to find the numerical cardinality of the solution sets, but were instead allowed to leave answers in the form $\binom{6}{2}$ instead of simplifying to 15. This indicated a level of sophistication that may not have been present before since by leaving their solutions in unsimplified terms, the students must be able to anticipate that their way of thinking will generate the entire solution set.

4.4.2.6. Task 26: Arizona

This task is a permutation with repetition problem and is phrased similarly to Task 1 in Individual Interview 1:

- Situation: Remember that Arizona has 7-character license plates. In an attempt to foster state pride, the DOT agreed to provide citizens who use the letters in the word “ARIZONA” arranged in any order with a special license plate with an image of the a Saguaro Cactus and the Cactus Wren as the background.
- Question: How many of these special license plates must the state create?

It was anticipated that students would be likely to engage in Equivalence Classes for this task. Once they completed the task, students would be asked to evaluate the validity of a solution driven by the Generalized Odometer way of thinking. This was the second way of thinking this study hoped to foster. Some of the following tasks had two Devil’s Advocates implemented after the students found the solution on their own – one driven by Equivalence Classes and the other driven by Generalized Odometer. In this

way, it was hoped that the students would extend their ways of thinking through assimilation.

4.4.2.7. Task 31: Mississippi II

This task was implemented in the final session of each phase. It was designed to serve as a post-test so that the researcher could observe the students' final ways of thinking. As a result, it was implemented in clinical interview style (Clement, 2000). The statement of the task follows:

- Situation: Consider the word *MISSISSIPPI*. We will be forming “words” from these letters.
- Question: How many “words” can be formed from the letters in “MISSISSIPPI” if:
 - i. We need 11-letter words created by rearranging the letters provided?
 - ii. We need 11-letter words created by rearranging the letters provided, and none of the I’s are next to each other?
 - iii. We need 11-letter words created by rearranging the letters provided, and all of the I’s come before the S’s and the M?
 - iv. We need 5-letter words, each letter may be used multiple times, and we cannot use the letter P?

The first question above is a more conventional phrasing of Task 1 and involves the operation of permutations with repetition. The remaining questions were designed to tie together many of the ideas from previous sessions. It was hoped that students would engage in many of the ways of thinking they had previously developed.

4.5. Methods of Analysis

At the end of each phase, the data corpus consisted of video and audio recordings of each interview and teaching experiment session, recordings of the researcher's debriefing sessions with a person with an outside perspective following each session, and students' written reflections following each session. From the data corpus, models of student's ways of thinking were constructed. These constructions were formed by using a coding system to develop grounded theory (Strauss & Corbin, 1998). In fact, an initial framework had already been developed from Pilot Studies 1 and 2. The ways of thinking identified in or theorized about in the pilot studies were then revised during the retrospective analyses after Phases 1 and 2, respectively.

The retrospective analysis consisted of a four-pass system. A summary of the system of retrospective analysis is in Table 5. Pass 0 describes the development of the ways of thinking identified during the pilot studies. Pass 1 involved creating content logs with a set of notes from Phases 1 and 2 of this study. Pass 2 involved the transcription of the eleven sessions and the development of a coding scheme. Pass 3 consisted of the coding of the transcripts. Finally, in Pass 4 the researcher reviewed the coded transcripts to see the development of student's ways of thinking throughout the study and identify the factors that influenced changes in ways of thinking.

Table 5. Passes of data analysis

System of Analysis	Purpose	Period
Pass 0	Development of Preliminary Framework	Before Fall 2011
Pass 1	Note-Taking and Creation of Content Logs	Spring 2012: During each phase

Pass 2	Revision of Framework & Development of Coding Scheme	Spring 2012: After Phase 1 and after both phases were complete
Pass 3	Transcription of Data and Coding of Transcripts	Summer 2012: After both phases are complete
Pass 4	Analysis of Evolution of Students' Ways of Thinking	Fall 2012 and Spring 2013

4.5.1. Pass 0 – Preliminary framework

The researcher developed a preliminary framework for identifying students' ways of thinking about combinatorics solution sets from Pilot Studies 1 and 2. See Table 6 for the initial framework. This preliminary framework was important in the design of the tasks and protocols used in this study.

In this initial framework, and the following sections, some terminology is used: In line with English (1993), the term *item* is used to refer to one of the objects involved in the counting process. For example, in the problem involving counting the number of permutations of {A, B, C, D}, A is an item. The term *element* is used to refer to elements of solution sets. In our example of permutations of the set {A, B, C, D}, A C B D is an element of the solution set. In tasks for this study, elements of the solution set can be thought of as having slots. Here, the terms *position* and *spot* refer to a slot. The item in the second position or spot in A C B D is C.

Table 6. Initial framework of ways of thinking

Way of Thinking	Characterization
Addition	Determine the size of one subset of the solution set. Add on the size of the complement of this subset
Partition	Partition the solution set of the problem into smaller sets. Recognize that the union of the smaller sets is the solution set of the original problem.
Standard Odometer	Hold the item in the first position constant. Vary the other items. Change the item in the first position and repeat.
Wacky Odometer	Hold one item * constant in a given position. Vary the other items. Change the position of * and repeat.
Generalized Odometer	Determine an array of items. Hold this array of items constant. Vary the other items. Change the position of the array of items.
Deletion	Consider a related problem whose solution set contains a subset which has a bijective correspondence with the solution set of the original problem. Find an additive relationship between the solution sets.
Equivalence Classes	Consider a related problem with a solution set which can be partitioned into equivalence classes of the same size – each one of which corresponds to an element of the original solution set. Find a multiplicative relationship between the solution sets.

Two of the ways of thinking in

Table 6 6, Equivalence Classes and Generalized Odometer, were described in greater detail in the Chapter 2. Most of the other ways of thinking described below were later revised. The final framework is presented in the next chapter.

4.5.2. Pass 1 – Content logs and note-taking

The first pass of analysis was a hybrid of on-the-spot and retrospective analysis (Steffe & Thompson, 2000). Following each individual interview and paired session, the researcher created content logs which included a narrative of the students' actions and responses during the session, partial transcriptions, and a set of notes. These notes belonged to one of the following categories: observational, methodological, or theoretical (Strauss & Corbin, 1998), and were labeled as such.

An example of a content log can be found in Appendix B. Examples of observational notes are “This student is still struggling to systematically list elements of the solution set”, “this student’s way of listing elements has been seen before”, “the student’s struggle could be important”. Methodological notes, on the other hand, are observations about the instruction to the students or other notes relevant to the design and methodology of the study. A review of these notes was essential for implementing changes to the tasks and protocols before the second phase, such as the design of the Venn Diagram Activity intervention. Examples of methodological notes are “This question was asked in a way that could be confusing to students,” “The researcher and the student were talking about two different things at this point. More effort will need to be taken in future sessions to clarify the students’ meanings.”

The final note type is theoretical notes – general conjectures to explain students' actions or words. These theoretical notes were informed by the ways of thinking identified in Table 6. Examples of theoretical notes are “This student seems to be holding one item constant while attempting to systematically vary the other items, which might be evidence of the Odometer way of thinking” and “this student does not seem to have

constructed a multiplicative relationship between the set of elements in the solution set of a related problem and the elements of the solution set of the original problem, which explains why he had difficulty finding the size of the solution set of the original problem.” Because the ways of thinking identified in Table 6 were used to explain students’ actions or words, we cannot say that the researcher truly engaged in open coding. However, the theoretical notes did not simply consist of statements such as “the student engaged in Equivalence Classes thinking” – instead, they had more explanations. This was essential so that the framework in Table 6 could be revised. These content logs were used to familiarize the researcher with the students and to plan for the next teaching experiment session.

4.5.3. Pass 2 – Creation of coding scheme

The second pass of analysis was conducted at the completion of each phase of the teaching experiment. The content logs created during the first pass of analysis facilitated the abstraction of general categories of behavior the students exhibited over the course of the phase. These categories of behavior and utterances were documented in order to suggest ways of thinking that make these behaviors and utterances sensible for the individual students. Patterns identified in the observational and theoretical notes then led to the identification of various ways of thinking. Though numerous ways of thinking were identified, only the fairly robust ways of thinking were included in a revised framework and served as a coding scheme for the data. In this Section, a definition of “robust way of thinking” is provided in 4.5.3.1 along with examples of non-robust ways of thinking. Then the final framework is presented in 4.5.3.2 with its comparison with the initial framework.

4.5.3.1. Criteria for robust ways of thinking

Two criteria were used to determine whether an identified way of thinking was a “robust” way of thinking for a student. These criteria will be called *applicability* and *strong cognitive root* in this dissertation. These criteria are similar to the ideas of emphasis and resonance, respectively, for identifying strong metaphors (Black, 1977; Oehrtman, 2002). Neither criterion requires that the student be able to reach a correct solution by engaging in the way of thinking. The criterion of applicability requires that a way of thinking must be applicable to solve multiple tasks. Just as the strong metaphor criterion of emphasis required a degree of commitment by the student to the metaphorical domain (Oehrtman, 2002), the robust way of thinking criterion of applicability requires a degree of commitment by the student to the way of thinking. Ways of thinking with applicability identified in this study were typically used by multiple students for multiple tasks in both this study and the pilot studies.

Much as the strong metaphor criterion of resonance requires that the metaphor would provide richness in background implications so that it could be transferred to other domains (Oehrtman, 2002), the strong cognitive root criterion for robust ways of thinking also requires that the way of thinking provide a richness in background implications for the student engaging in the way of thinking. In the context of ways of thinking about combinatorics solution sets, the strong cognitive root criterion means that the way of thinking would provide a student with the means to reason about the elements of the solution set and the relationships between the elements, and that this way of thinking could be transferred to other tasks.

Three ways of thinking, identified as *Broken Odometer*, *Disney*, and *Weak Problem Posing* emerged from the data during open coding in the second pass of the analysis. Indeed, Broken Odometer thinking failed the first criterion for robust ways of thinking and both Disney and Weak Problem Posing thinking failed the second criterion. Therefore, none of these ways of thinking were included in the final framework summarized in Table 7. The remaining three subsections of this Section provide the definitions of Broken Odometer, Disney, and Weak Problem Posing ways of thinking, respectively, examples of students engaging in these ways of thinking, and to what extent each of these ways of thinking failed a criterion for the robust ways of thinking.

4.5.3.1.1. Broken Odometer

Broken Odometer is one way of thinking identified during data analysis but not included in the final framework. This way of thinking entails the following mental acts: first, place an item in a slot. Then, systematically vary items in the other slots in an effort to generate all elements of the solution set. In a sense, a student engaging in Broken Odometer would be holding the first item constant while varying items in the other slots. This is akin to the *odometer strategy* (English, 1991, 1993) discussed in Section 3.1 above. However, another item would not be held constant in first position. In that sense, the odometer is broken. This way of thinking is illustrated below with Kate's way of thinking observed when she was working with Task 18: Table during the second individual interview in Phase 1 (P1_II2_K). The statement of this task is below.

- Situation: A bunch of people would like to sit around a large, round table. It doesn't matter to them which particular seat they sit in, but they do care about the people who will be sitting to either side of them.

- Question: In how many ways can n people sit around a circular table?

For this problem, after a short pause to figure out a problem solving approach, Kate chose to determine the number of ways to place other people around one person. She began with 3 people and used cards with the letters A , B , and C to create different arrangements representing the elements of the solution set. She placed the card with A down and then realized there were two ways to place the other two people, using the cards to do so. She moved to 4 people, and arranged the cards to figure out that there were six ways to place the other people around the one person she had first put down. She explained, “I’m just holding A constant, I guess, and moving people around A .” By her own admission, Kate was holding one item constant and systematically varying the other items. Kate’s way of thinking at this point is thus similar to the odometer strategy from English (1991). However, she did not take into account changing the position of the first item, or changing which item was being held constant in that position. In that sense, her odometer thinking was broken. Kate’s solution to the Table problem was therefore identified as driven by Broken Odometer thinking.

Broken Odometer thinking does have strong cognitive roots for a student in the sense that a student engaging in this thinking could envision the elements of the solution set and how they were all related based on the element with its location fixed (e.g., the location of A in Kate’s case). It can be a powerful way to reason about tasks involving the operation of circle permutations since it does provide students with a way to generate all of the elements of the solution set and see their relationship to one another. Thus, Broken Odometer thinking satisfies the second criterion for a robust way of thinking. On the other hand, the Broken Odometer way of thinking does not satisfy applicability, the

first criterion for a robust way of thinking, since Kate did not engage in this way of thinking for any of the other tasks. In addition, neither Al nor Boris engaged in Broken Odometer at all. In the pilot studies, a couple of students engaged in this way of thinking for the Table problem, but not for any of the other tasks. As a result, the Broken Odometer way of thinking was not included in the framework in Table 7.

4.5.3.1.2. Disney

Disney is another way of thinking in which students engaged but which was not included in the framework. This way of thinking involves moving one item through the others before moving another item through the items. This process would continue in an effort to generate all elements of the solution set.

Disney thinking was often seen at the beginning of the study when students attempted to vary the items involved in the counting process. Consider the following example. While trying to solve Task 1 Mississippi I, which ultimately required students to permute the letters in Mississippi, Al rearranged the letters in Mississippi to be MIIIPPSSSS. He then said that the first S could be moved to the left and used arrows to indicate where it could go, as shown in Figure 8. He therefore created other elements of the solution set, though not all of the elements were shown. Once the first S had been moved through, he indicated that the next S would be moved through (the arrows are shown in grey in Figure 8). This is indicative of Disney thinking.



Figure 8. Example of Disney Thinking

Essentially, a student engaging in Disney would be attempting to create each element of the solution set by using an adjacent transposition. For permutations of distinct items, it is possible to generate all possible permutations using adjacent transpositions, but this must be done recursively. In other words, the students must be attending to the other items involved in counting. However, under Disney thinking, students would not be attending to the other items. Indeed, consider the example of Jack below for which this way of thinking was named.

In Pilot Study 1, Jack described his way of thinking after he had engaged in it to permute four distinct cards (Halani, 2012b).

Excerpt 1. Permutation of four distinct cards from Pilot Study 1

Jack: It brought me back to like childhood memory of like watching, um, I don't know Disney. An old Disney cartoon where like, they're teaching you something, right? Or, or something. I don't even know how to um, if that's right, but I just remember like visualizing patterns. Maybe like, I visualize each of these cards next to each other, but like one of them moving over (moves the card in the last position to the first position), but it was lit up. That's just what I saw in my head. I don't know why. [...] For some reason, this image of a lit-up letter on a card just kind of. Um, I just saw it um, taking turns (holds one card and moves it through

the air) in each spot. [...] [The other cards] are just kind of moving over. Um, all I can visualize is the lit-up one moving.

From Jack's description, it is inferred that students engaging in Disney thinking may not be attending to the other items involved in the counting process. This can be problematic because students would not be aware of the relationships between elements of the solution set. Thus, this way of thinking does not have strong cognitive roots. During Pilot Study 1, Ricardo attempted to determine the number of permutations of 5 distinct letters by holding one letter constant and engaging in this way of thinking for the other letters (Halani, 2012b). Like Al and Jack, Ricardo was not attending to the position of the other letters as he was moving a letter through. He thus found only 10 of these permutations instead of the full 24. Again, the example of Ricardo shows that this way of thinking is not productive for generating all of the elements of the solution set since the students are not aware of the relationships between elements of the solution set. Therefore, this way of thinking does not have a strong cognitive root.

Disney thinking satisfies the applicability criterion of a robust way of thinking. All three students participated in this study engaged in Disney way of thinking for the first task, Mississippi I, in an effort to vary the items involved in the counting process. In addition to Jack and Ricardo, other students in Pilot Study 1 applied this way of thinking to other tasks (Halani, 2012b). Thus, this way of thinking was applied to multiple tasks, by multiple students. Since Disney thinking does not have a strong cognitive root, however, it was not considered a robust way of thinking and was therefore not included in the framework.

4.5.3.1.3. Weak Problem Posing

Weak Problem Posing, or *Weak PP*, is another way of thinking which emerged from the data analysis but which failed the second criterion for robust way of thinking. This way of thinking entails the following mental acts: First, pose a new, related combinatorics question (for the convenience, the solution set of the original task will be called the “original solution set” and the solution set of the newly posed question will be called the “new solution set.”) Second, generate all elements of the new solution set (perhaps by trial-and-error). Third, identify elements of the new solution set with elements of the original solution set. Fourth, list out elements of the original solution set. This last mental act could be completed in a couple ways. One way would be to simply list elements of the original solution set which had not yet been listed, ignoring the ones which had been. Alternatively, one could list out all of the corresponding elements of the original solution set and, cross out any encountered elements that have already been listed.

Consider the task below which was called the “Wellesley Problem” during Pilot Study 1.

- Situation: The State of Massachusetts entered into a special agreement with Wellesley College, which is located in Wellesley, MA. Since Massachusetts is adopting new, 9-letter license plates, the state agreed to provide citizens who use the letters in the word ‘WELLESLEY’ arranged in any order with a special license plate with the blue Wellesley ‘W’ logo in the background.
- Question: How many of these special license plates with the ‘W’ logo must the state create?

When presented with the Wellesley problem, Frank from Pilot Study 1 was reminded of some work he did for the company at which he was interning. His description of his work for his company and its relevance to the Wellesley problem is in Excerpt 2.

Excerpt 2. Permutation of WELLESLEY from Pilot Study 1

Frank: When I was hired, we didn't really have document numbering or really anything so I had to [...] come up with a document numbering scheme. And I thought it was going to be a pain when we get to like the thousands and thousands numbers of documents, to check whether or not this number was available. So I wrote like a short program in C++ that [...] used numbers arranged them randomly and then checked a text file to see if that number was already there. If it wasn't, then it made it and assigned a document to that number. If it was then it arranged the numbers again [...] I would think that it [the Wellesley problem] would be a lot easier if it was like 1 2 3 4 5 6, um, I think that it would probably just be the fact that there are multiple letters that are the same in this that would be confusing, or that would throw somebody off. Because it has 3 E's and 3 L's. Whereas if you just number it off 1 2 3 4 5 6, there isn't two 2's or two 1's [...] If I was writing a program for this, um, you can store like a string, like it would store multiple 1's and 2's and stuff like that and randomly generate them. So pretty much you would just be doing the same thing, [...] [and] all of the duplicates you would just um, get rid of."

Frank's initial inclination when he saw the Wellesley problem was to connect the problem to something he had already done. At his job he devised a document numbering program which would automatically generate a random number for a document. The program would check a list of numbers to see whether this number had already been used. If it had not already been used, the document would be assigned that number and the number would be added to the list. If it had already been used, it would generate a new number and the process would repeat until a number that had not been used was generated. Frank attempted to apply similar reasoning to the Wellesley problem.

Instead of discussing permutations of WELLESLEY, Frank initially preferred to generate random strings of numbers. He recognized that the 3 Ls and 3 Es in the Wellesley problem added a level of complexity to the task, which is why he said it would be easier if the numbers were distinct. His solution to this was to have the program generate strings of numbers (with repetition). The program would then check whether the string had already been used, getting rid of the strings which were not useful.

The interviewer asked Frank how his strings tied exactly to the Wellesley problem. Upon further questioning, Frank indicated that the program would first generate an arrangement of the letters in $WE_1L_1L_2E_2SL_3E_3Y$, then "flatten" the word so that the subscripts were removed. Then the program would check a list it was maintaining to see if the flattened word WELLESLEY was already there. Frank said that the number of license plates that the state must be prepared to create would be the length of the list that the program generated. However, when asked how he would know when the program was finished, he admitted that he did not know.

Frank's mental acts while solving working on the Wellesley problem could be summarized as follows: First, he randomly generated an element of the solution set of a new problem (consisting of permutations of $WE_1L_1L_2E_2SL_3E_3Y$) and then determined a relationship between this element of his new solution set and an element of the solution set whose size he was trying to count (consisting of permutations of WELLESLEY). In this case, the relationship was determined by removing the subscripts. He used this relationship to create a list of permutations of WELLESLEY. Thus, it appears as if Frank engaged in Weak Problem Posing. A simulation of Frank's way of thinking is shown in Figure 9.

Step of Process	Permutation of $WE_1L_1L_2E_2SL_3E_3Y$ Generated for This Step	List of permutations of WELLESLEY at This Step
1.	$L_1L_2E_2SL_3E_3YWE_1$	LLESLEYWE
2.	$L_3E_3SYL_1WE_1L_2E_2$	LLESLEYWE LESYLWELE
3.	$SYL_1E_3E_1WL_3L_2E_2$	LLESLEYWE LESYLWELE SYLEEWLLE
4.	$L_2E_1SYL_3WE_2L_1E_3$	LLESLEYWE LESYLWELE SYLEEWLLE
⋮

Figure 9. Example of a solution driven by Frank's way of thinking

Weak Problem Posing was not a robust way of thinking for any of the students since it failed the strong cognitive root criterion. Indeed, there are two main limitations for this way of thinking. First, the way of thinking requires the generation of all elements

of the new solution set and the listing of all elements of the original solution set. The final answer to the question whose solution Weak Problem Posing was driving could be determined by finding the length of the final list of elements of the original solution set. If this list is long, it could be difficult for a student to determine if an element of the original solution set was accidentally listed twice. This is because the student, though he or she had found a relationship between elements of the two solution sets, would not have found relationships between elements of the original solution set. Frank incorporated the idea of a computer program to address this limitation. However, even if he had written a computer program which would count the elements on the list, he would not know when the list was complete. This is the second limitation of the way of thinking. Indeed, because Frank was randomly generating elements of the new solution set, he would have no way to ensure that all elements of the new solution set had been generated, and therefore whether all elements of the original solution set had been listed. This could be the result of not envisioning a clear relationship between elements of the new solution set. A lack of understanding of the relationships between elements of a solution set is the cause of both of these limitations; the absence of such an understanding indicates that the way of thinking does not have a strong cognitive root.

Weak Problem Posing does satisfy the applicability criterion for a robust way of thinking. Indeed, other students engaged in Weak Problem Posing for other tasks in this study and in the pilot studies (see Section 7.2.2.1.1 below for another example). However, Weak Problem Posing is not considered as robust since it failed the second criterion.

4.5.3.2. Final framework

The revised framework is shown in Table 7 and all of the ways of thinking included are robust. It was loosely based on the initial framework determined during Pilot Studies 1 and 2 (see Table 6). However, many of the characterizations of the ways of thinking were revised and expanded through the data analysis of this study, and an additional way of thinking was added. During the third pass of data analysis, discussed below, the ways of thinking in the framework were categorized based on their characteristics. The categories which emerged are called *Subsets*, *Odometer*, and *Problem Posing*. The following chapters are each devoted to one of these categories. Though these categories contain the robust ways of thinking from the final framework, they could also contain non-robust ways of thinking. Indeed, Broken Odometer is an Odometer way of thinking and Weak Problem Posing is still a Problem Posing way of thinking.

Table 7. Ways of thinking about combinatorics solution sets

Category	Way of Thinking	Characterization
Subsets	Addition	First, think locally, consider a subset of the solution set and find its size. Second, consider another subset of the solution set and find its size. Then, continue this process until exhaustion of the elements of the solution set.
	Union	Consider the entire solution set and envision it as the union of subsets. Then, count the size of the solution set. Think globally.
Odometer	Standard Odometer	First, determine the number of items which could be placed into a given position. Then, for each of those placements, determine the number of ways to place items in the other positions in an effort to construct the entire solution set.
	Wacky Odometer	First, determine the number of positions in which a given item could be placed. Then, for each of those placements, determine the number of ways to place items in the other positions in an effort to construct the entire solution set..
	Generalized	First, select a set of items to be held constant. Next, determine the number of

	Odometer	ways to place these items in slots. Third, for each of those placements, systematically vary items in the other slots in an effort to construct the entire solution set.
Problem Posing	Deletion	First, consider a given problem. Second, pose a related problem whose solution set contains a subset which has a bijective correspondence with the solution set of the original problem. Third, find an additive relationship between the solution sets. Fourth, find the cardinality of the new solution set. Next, determine the size of the complement of the subset of the new solution set which corresponds to the original solution set. Finally, use the additive relationship to quantify the size of the original solution set
	Equivalence Classes	First, consider a given problem. Second, pose a related problem with a solution set which can be partitioned into blocks of the same size – each one of which is in a bijective correspondence with an element of the original solution set. Third, find a multiplicative relationship between the solution sets. Next, quantify the size of the new solution set and of each block. Finally, use the multiplicative relationship to quantify the size of the original solution set.
	Ratio	First, consider a given problem. Next, pose a related problem with a solution set which can be partitioned into blocks of the same size – each one of which has the same number of “wanted” elements which are in a bijective correspondence with elements of the original solution set. Third, quantify the size of the new solution set. Fourth, find the ratio of “wanted” elements to total elements in each block. Finally, use this ratio to determine the size of the original solution set.

With the exception of Deletion and Equivalence Classes, the characterizations of all of the ways of thinking were modified in some way. There are two other important changes: (1) “Union” thinking was renamed from the original title of “Partition.” (2) An additional way of thinking emerged from the data analysis of the second phase of the study. This way of thinking is called “Ratio” in the final framework.

4.5.4. Pass 3 – Transcription of the data and coding of transcripts

The ways of thinking in the final framework formed the basis of the coding scheme, which can be seen in Table 8. The colors and the symbols are both important in the coding scheme. Once this coding scheme had been created, the third pass of retrospective analysis was conducted: the creation of full transcripts of students’

utterances and actions in each session and interview, and the coding of the transcripts in Microsoft Excel. This pass was conducted once all data were collected.

Table 8. Coding scheme

Symbol	Category or Way of Thinking
OD	Odometer Category
S	Standard Odometer
W	Wacky Odometer
G	Generalized Odometer
\subseteq	Subsets Category
+	Addition
\cup	Union
POS	Problem Posing Category
D	Deletion
\sim	Equivalence Classes
/	Ratio

This coding process was conducted by analyzing a whole sentence or paragraph of student utterances at one time. While coding a paragraph, the researcher asked herself “What are the major ways of thinking driving this paragraph?” If these ways of thinking were included in the coding scheme, then that portion of the transcript was coded according to the indicated way of thinking and the category to which it belonged. Often, multiple ways of thinking were brought out by the same paragraph. This was not an issue since that paragraph was coded using both ways of thinking. Occasionally, a student’s utterance indicated that he or she was engaging in a way of thinking belonging to a particular category of the framework, but either the way of thinking was not included in the framework or the specific way of thinking was not clear from the utterance. In these cases, the utterance was coded solely by the category. For example, when Kate engaged

in Broken Odometer as discussed above, it was coded as OD, but not as any of the other Odometer ways of thinking.

An example of the implementation of the coding scheme from Table 8 can be seen in Table 9. Here, the first few sentences of Kate’s utterance were colored orange since they seemed likely to be driven by a way of thinking belonging to the Odometer category, which is orange in the coding scheme in Table 8. In particular, those sentences were coded as Wacky Odometer thinking. Her next sentence was coded as belonging to Subsets thinking, particularly Union thinking, and was therefore colored blue.

Table 9. Example of coded data from P1_PS2

NAME:	TRANSCRIPTION	OD	S	W	G	\subseteq	+	\cup	POS	D	~	/
Kate	So again I was moving the D around and so D is in the first space. The second space there are six possibilities cause none of them have been eliminated. And third place there are another six possibilities. And then you have to multiply that by three because the D could be in three different places and there are the same number of possibilities for each place the D is in. So you'll end up with six times six times three. which is a hundred and thirty six eight and times yeah.	x		x		x		x				

There were times when a single paragraph seemed to correspond to two ways of thinking belonging to the same category. In those instances, the researcher separated the

paragraph into two rows so that each row could be coded using at most one way of thinking from each category. There were also times when it seemed clear that the student was engaging in a way of thinking belonging to one of the three categories, but it was not clear in which particular way of thinking he or she was engaging, or when the way of thinking had not been added to the coding scheme. In those cases, the utterance was coded based on the category, but not as being driven by a particular way of thinking.

During this same pass, the researcher engaged in axial coding to identify the variety of conditions associated with each category and classify how major categories related to one another (Strauss & Corbin, 1998). She did the axial by using the “Sort” function in Excel to group paragraphs relating to one or more categories together and examining the entire data corpus as a whole to look for patterns. It was during this portion of the data analysis that the categories shown in the final framework emerged.

4.5.5. Pass 4 – Analysis of evolution of ways of thinking

In this pass of retrospective analysis, the researcher identified sources of perturbation for the students, and analyzed the evolution of their ways of thinking as they resolved these perturbations. She used the coded transcripts to track changes in the students’ ways of thinking. She further investigated the factors that influenced changes in ways of thinking. Finally, she used examples from the data to construct a model that could describe the evolution of the ways of thinking of an epistemic student. In particular, she focused on the evolution of the Problem Posing ways of thinking. More information about this model can be found in Section 7.2.

5. SUBSETS WAYS OF THINKING

For some counting problems, it can be beneficial for students to view the solution set as consisting of different groups, or subsets, based on some criteria. These criteria can be found by decomposing the problem into separate cases – each of which corresponds to a particular criterion. The idea of decomposing a problem and working on it in a case-by-case basis is present in literature related to problem solving (Gick, 1986; Nunokawa, 2001; Polya, 1957; Schoenfeld, 1979, 1980, 1985, 1992). In fact, Schoenfeld investigated the effect of problem solving strategy instruction on student performance. One of the explicitly included strategies stated, “Try to establish subgoals. Can you obtain part of the answer, and perhaps go on from there? Can you decompose the problem so that a number of easier results can be combined to give the total result you want?” (Schoenfeld, 1985, p. 195). Based on the results of his study, Schoenfeld reported that it was difficult for students to know how to decompose problems. In the domain of combinatorics, as discussed in Section 3.2 above, Lockwood (2011a) demonstrated that for the task of determining the number of case-insensitive eight-letter passwords which use at least 3 Es, it can be helpful to examine cases based on the criteria of the exact number of Es in a password. The solution set of the passwords problem can therefore be viewed as the union of subsets – one which contains passwords with 3 Es, another which has 4 Es, etc. However, many of the students in Lockwood’s study did not use this case-by-case analysis (perhaps because they did not know how to decompose the problem in this manner) and ultimately grossly over counted the size of the solution set. Thus, it appears as if much can be learned from students’ use of problem decomposition in the context of combinatorics, which is the focus of this chapter.

This chapter discusses the ways of thinking belonging to the Subsets category of the final framework of ways of thinking. First, this chapter presents definitions and examples of the two Subsets ways of thinking included in the framework: Addition and Union. Next, it discusses how Subsets thinking is related to the error of over counting the size of the solution set and describes the Venn diagram activity implemented in the second phase of the study to in an attempt to address this error. Finally, this chapter provides a discussion of the visualizations that A1, the student in the second phase of the study, used to explain his reasoning related to Subsets thinking.

5.1. Subsets Ways of Thinking from the Framework

Two ways of thinking, both of which ultimately involve students envisioning the solution set as the union of subsets, comprise the Subsets category of the final framework of ways of thinking. Both of these robust ways of thinking emerged from the data analysis of this study. Essentially, they involve breaking the solution set into subsets, each of which satisfies a specific case. One of them, *Addition*, involves a local approach to problem solving, whereas the other, *Union*, involves a global one. In the context of combinatorics, a local approach would be to consider only part of a solution set at a single time whereas a global approach would be to consider the entire solution set. In other words, the first approach would be to consider a single case and determine the number of elements which satisfy that case before considering any other cases; the second, global approach would break the problem into cases first, before finding the number of elements which satisfy each case. For both approaches, a final solution to the combinatorics problem could involve summing the sizes of the subsets. As a result, a typical indication of Subsets thinking is the use of the addition operation.

The subsections below provide characterizations of Addition and Union, respectively, along with examples of students engaging in each. The characterizations are summarized in the following table.

Table 10. Subsets ways of thinking

Category	Way of Thinking	Characterization
Subsets	Addition	First, think locally, consider a subset of the solution set and find its size. Second, consider another subset of the solution set and find its size. Then, continue this process until exhaustion of the elements of the solution set.
	Union	Consider the entire solution set and envision it as the union of subsets. Then, count the size of the solution set. Think globally.

5.1.1. Addition

One way some students ultimately ended up envisioning the solution set as the union of smaller subsets was present when students began by thinking locally. This way of thinking is called *Addition* in this study. Consider Task 6: Books whose statement is below.

- Situation: Suppose there are 5 different algebra books, 6 different geometry books, and 8 different calculus books.
- Question: In how many ways can a person pick a pair of books if they must choose books on different subjects?

Kate and Boris encountered this task during the first paired session in Phase 1. They were asked to spend a few seconds thinking about the task on their own before coming together to discuss approaches to the problem. Kate's response is in Excerpt 3.

Excerpt 3. Task 6: Books from P1_PS1

Kate: So...um I did the hold one constant thing again. Um...so I'd break them up like the algebra books are A1, A2, A3, A4, A5.

Aviva: Why don't you write this down?

Kate: So I'd have A1 [Writes A_1] and geometry 1 through 6 [Writes G_{1-6}] and calculus 1-8 [Writes C_{1-8}]. And if you keep doing that you'd end up with 14 times 5 for when you hold the algebra books constant. And then you could do it again [...] like with holding a geometry book constant.

In the above excerpt, Kate seemed to have focused first on elements in the subset of the solution set which involved pairs containing an algebra book. She only references pairing the first algebra book with the six geometry and eight calculus books, but her calculation of 14 times 5 indicates that she would have done the same thing for all five of the algebra books. She then considered the subset of the solution set which involved pairs containing a geometry book.

Addition thinking entails the following mental acts: First, consider a subset of the solution set and find its size. Second, consider another subset of the solution set and find its size. Third, continue this process until exhaustion of the elements of the solution set. This process involves thinking locally, applying a local approach.

Kate's response in Excerpt 3 was indicative of Addition thinking because she first considered just a single subset of the solution set and found its size before considering the elements in another subset of the solution set. Kate recognized that A_1G_1 , the pair containing the first algebra book and the first geometry book, would be counted in both

the subset containing algebra books and the subset containing geometry books and that it should not be counted twice. However, she struggled to determine all of the pairs that would be over counted. Kate and Boris worked together to finish Task 6: Books.

Ultimately, they determined that for each of the algebra books, there were 14 other books which could be paired with it. Since there are five algebra books, they found that there were 14×5 pairs of books which involve an algebra book. They then realized that they needed to also consider the pairs which involved a geometry and calculus book, which totaled 6×8 . Their final solution was $14 \times 5 + 6 \times 8$. Notice that the students broke the problem into cases: case 1) an algebra book is included in the pair and case 2) an algebra book is not included. Their final expression summed the answers determined for each case. Again, a typical indication of Subsets (Addition in this case) thinking is the use of the addition operation in the final expression for the size of the solution set.

Expressions for solutions driven by Addition thinking could involve the multiplication operation. Indeed, Kate engaged in Addition thinking when she attempted to permute the letters MISP during the first individual interview. She first considered only the permutations which began with the letter M, finding the size of corresponding subset of the solution set to be six. She then recognized that she could have permutations which began with I, S or P, and that each of these cases also had six elements in its corresponding solution set. Her final answer was 4×6 .

The students in this study engaged in Addition thinking frequently, and so the way of thinking satisfies the applicability criterion of robust ways of thinking. In addition, Addition thinking provided a way for students to reason about the relationship between elements of the solution set – namely that they can be grouped as corresponding

to different cases. Therefore, Addition satisfies the strong cognitive root criterion and is considered a robust way of thinking.

5.1.2. Union

In contrast to Addition thinking which involves thinking locally first, *Union* thinking takes a global approach to problem solving. Union thinking entails first considering the entire solution set and envisioning it as the union of subsets before counting the size of the solution set. Counting methods for each subset in Union thinking could vary. One method in which students engaged was to simply take the sum of the sizes of the subsets. Another option would be to partition the union into disjoint subsets and find the sum of the sizes of these disjoint subsets.

It can be difficult to ascertain whether a student is engaging in Addition or Union thinking. Indeed, when observing a student first finding the size of a subset of the solution set and then adding on the size of another subset, it could be difficult for the researcher to determine if the student had mentally considered the entire solution set first, and then focused on a subset. In such a case, it was considered enough to say that the student was engaging in Subsets thinking.

Given the difficulty in determining the difference between the two Subsets ways of thinking, one might wonder whether they are actually two distinct ways of thinking. An example might help clarify the difference between Addition and Union thinking. After Kate and Boris solved Task 6: Books and found the solution to be $14 \times 5 + 6 \times 8$ (see Section 5.1.1), they were presented with a Devil's Advocate driven by Union thinking attributed to a former student, Polly:

Polly's argument for Task 6: We have three different cases based on the types of books chosen: We can either have an Algebra book and a Geometry book, an Algebra book and a Calculus book, or a Geometry book and a Calculus book. Each Algebra book can be paired with 6 Geometry books, so we have 5×6 pairs with Algebra and Geometry. Each Algebra book can be paired with 8 Calculus books, so we have 5×8 pairs with Algebra and Calculus. Finally, each Geometry book can be paired with 8 Calculus books, so we have 6×8 pairs with Algebra and Calculus. Altogether, we have $5 \times 6 + 5 \times 8 + 6 \times 8$ total pairs of books from different subjects.

During this study, after a Devil's Advocate was presented, students were always asked to reinterpret the argument in their own words. Kate's response can be seen in the following excerpt:

Excerpt 4. Task 6: Books from P1_PS1

Aviva: Ok, in your own words, can you explain Polly's argument?

Kate: So instead of holding something constant, she [Polly] [...] took the 3 groups and made [...] them groups of 2 [types of books] and figured out how many were in each group of 2. And added them together

Aviva: What do you mean by "how many are in each group of 2?"

Kate: Well...so she took out algebra, calculus, and geometry and instead of dealing with [...] one algebra book and seeing how many [...] pairs could be made with that one algebra book, like we did, [...] she took the three types of books and said algebra and geometry, how many combinations? So algebra and geometry are

there, then algebra and calculus, how many there are... I hadn't thought of that at all!

In the above excerpt, Kate's statement "instead of holding something constant" indicates that she views Polly as approaching the problem in a different manner than how she had previously. She summarized her previous approach by saying that she and Boris had tried to "deal with one algebra book" first, and indicated that Polly had instead split the solution set into "groups of two," which likely refers to subsets of the solution set that only involve two types of books. Her final statement "I hadn't thought of that at all" indicates that to Kate, at least, her argument was very different from Polly's. This supports the idea that Addition and Union are two distinct ways of thinking.

The students engaged in Union thinking often during this study. As an example, consider Task 16(iii): Sororities whose statement is below.

- Situation: A university decides that sorority names can be three-letters chosen from the following Greek letters: $\Gamma, \Delta, \Theta, \Lambda, \Pi, \Phi, \Psi, \Omega$
- Question: How many sorority names can be formed from these letters if repetition of letters is allowed and the letter " Θ " must be used.

Al's response was "Well, if Θ must be used, then it can be either in the first slot, the second slot or the third slot." As he said this, he drew the three sets of slots shown in Figure 10. As he said "first slot," he wrote a 1 in the first slot of the first set of slots. As he said "second slot," he drew a 1 in the second slot of the second set of slots. He drew the third 1 as he said "third slot." He then filled in the remaining slots and found the solution to be $64+56+49$ (see Figure 10).

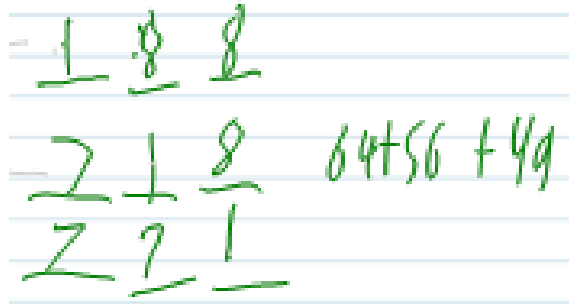

Figure 10. Al's written work for Task 16 (iii): Sororities

Al's construction of the three sets of slots in Figure 10 and his statement seemed to indicate that he was constructing three subsets of the solution set – the first had Θ first, the second had Θ second, and the third had Θ third. In terms of cases, we could say that he first considered a case where Θ is first, a case where Θ is second, and a case where Θ is third. He then considered the number of elements which would satisfy each case. This is indicative of Union thinking since he took a global approach to the problem and envisioned the solution set as the union of subsets first.

Notice that Al's final expression involves the addition operation. Again, a typical indication of Subsets (Union in this case) thinking is the use of the addition operation in the final expression for the size of the solution set. However, as with Addition thinking, a solution could be driven by Union thinking though the final solution might not involve the addition operation. Indeed, a student permuting four distinct items would be said to be engaging in Union thinking if she first determined that there were four items which could go first in the permutation – she would be envisioning the solution set as the union of subsets based on the first letter in the permutation. Her final solution of 4×6 would involve the operation of multiplication, but her reasoning was driven by Union thinking.

As mentioned previously, all three students in this study often engaged in Union thinking, which indicates that this way of thinking satisfies the applicability criterion for robust ways of thinking. In addition, Union thinking provided students with a way to reason about the relationship between elements of the solution set by grouping the elements. For example, it allowed Al to group elements of the solution set based on the criterion of the location of Θ in the name. Thus, Union satisfies the strong cognitive root criterion as well and is considered a robust way of thinking.

5.2. Over Counting and Subsets Thinking

Students engaging in Subsets thinking ultimately view the solution set as the union of subsets which they may believe to be disjoint. If the subsets are disjoint and every element of the solution set is accounted for in a subset, the cardinality of the whole solution set is the sum of the sizes of the subsets. Sometimes, if the subsets are not disjoint but the students are unaware of this fact, the students might over count the number of elements in the solution set. Indeed, they might count the elements in the intersection of two subsets twice – once when they find the size of the first subset, and again when they find the size of the second. This Section first provides an example from the data which relates Subsets thinking to the error of over counting. Then, it describes the Venn Diagram Activity which was implemented in the second phase of the study in an effort to address the error of over counting. Finally, it provides Al's visualizations of Subsets thinking.

5.2.1. Example of over counting with Subsets thinking

Consider Task 14(vi): Letters abcdef whose statement is below.

- Situation: Suppose we have the letters a, b, c, d, e, f and we are forming three-letter strings of letters (“words”) from these letters.
- Question: How many 3-letters “words” can be formed from these letters if repetition of letters is allowed and the letter “ d ” must be used.

In the first paired session of Phase 1, Boris and Kate’s final expression for the size of the solution set was $6 \times 6 \times 3 = 108$. Kate’s explanation is in the following excerpt.

Excerpt 5. Task 14(vi): Letters abcdef in P1_PS1

Kate: I was moving the “ d ” around and so [if] “ d ” is in the first space, [for] the second space there are 6 possibilities ‘cause none of them [a, b, c, d, e, f] have been eliminated, and [for the] third place there are another six possibilities. And then you have to multiply that by three because the “ d ” could be in three different places and there are the same number of possibilities for each place the “ d ” is in. So you’ll end up with 6 times 6 times 3.

In her explanation in Excerpt 5, Kate first mentions moving the “ d ” around. This indicates that she first decomposed the entire solution set into three subsets based on the location of “ d ” in the “word,” which is indicative of Union thinking. Kate reasoned that each of these subsets has 6×6 elements, and there were therefore a total of $6 \times 6 \times 3$ elements in the solution set.

Notice that Kate’s approach in Excerpt 5 results in over counting the elements of the form $dd_$, d_d , and $_dd$. Indeed, under Kate’s reasoning, a “word” of the form $dd_$ would be counted once in the 6×6 elements of the first subset and a second time in the

6×6 elements of the second subset. Kate's over counting in this problem was not an isolated case. In fact, both Boris and Al found the solution to be 108 as well.

Schoenfeld (1985) found that students do not always know how to decompose a problem into cases. The example above demonstrates that even if a student can decompose a problem into cases, she still may not be successful in determining a correct solution to a task. By considering cases based on the location of "*d*," Kate found a relationship between elements of the solution set and grouped the elements accordingly. However, Kate did not appear to be aware of the relationship between her *subsets*.

5.3. Visualization of Subsets Thinking

During Phase 1 of this study, the researcher conjectured that though students may ultimately *envision* a solution set as the union of subsets, they may not be able to *visualize* this union and that the students' over counting of the size of the solution set might be a result of their lack of visualization. In this study, "envision" is used to refer to the way in which the student considers the relationship between elements of the solution set – the way he or she sees the relationship. As discussed in Section 2.4.2, "visualization" is used in this study to refer to the process of constructing and transforming mental visual images.

In between Phases 1 and 2, as the researcher engaged in retrospective analysis of Phase 1, she designed a manipulative intervention involving Venn diagrams to help students visualize solution sets as the union of smaller subsets. The Venn diagrams the researcher used were pedagogical content tools (PCTs) – they were visual images the researcher used with the intention of connection to Al's Subsets thinking and to advance

the mathematical agenda by helping him visualize the elements which could be over counted through Subsets thinking. This intervention was called the *Venn Diagram Activity*.

5.3.1. Venn Diagram Activity

There were two parts to the intervention to encourage visualization of Subsets thinking – the first involved viewing the solution set as the union of two subsets and the second involved three subsets. Both portions of the intervention were implemented through Devil’s Advocates during Task 14: Letters abcdef – the Two Set Venn Diagram Activity was implemented for part (iii) and the Three Set Venn Diagram Activity was for part (vi). The statement of Task 14 is below.

- Situation: Suppose we have the letters a, b, c, d, e, f and we are forming three-letter strings of letters (“words”) from these letters.
- Questions: How many 3-letters “words” can be formed from these letters if
 - i. Repetition of letters is not allowed
 - ii. Repetition of letters is not allowed and the letter “ d ” must be used.
 - iii. Repetition of letters is not allowed and either the letter “ d ” must be used or the letter “ a ” must be used, but not both
 - iv. Repetition of letters is not allowed and either the letter “ d ” must be used or the letter “ a ” must be used, or both must be used.
 - v. Repetition of letters is allowed
 - vi. Repetition of letters is allowed and the letter “ d ” must be used.

The subsections below detail the implementation of the Venn Diagram Activity during Phase 2. These descriptions are intended to provide the reader with a sense of how

Al was introduced to Venn diagrams. Al's use of Venn diagrams following the intervention is described in Section 5.3.2.

In the Venn Diagram Activity, formal set theoretic language was not used. In a large part, this decision was based on the research that students have trouble with visualizing and representing set expressions (Bagni, 2006; Hodgson, 1996). Instead, the researcher adopted Al's natural language. For example, Al called the intersection of two sets the "overlap" and the researcher used this terminology as well.

5.3.1.1. Two Set Venn Diagram Activity

Al was asked during the fourth session of Phase 2 to solve Task 14(iii): Letters abcdef (see above). Al first argued that if "a" were used, it could go in three spaces, and there would be 5×4 ways to place the letters in the other slots, so that there were $5 \times 4 \times 3$ total "words" involving the letter "a." He then argued that there would be the same number of "words" involving the letter "d" for a total of $2 \times 5 \times 4 \times 3$. He realized that this expression had the same numerical value as the total number of 3-letter "words" that could be formed where repetition is not allowed. He adjusted his solution to require that "d" not be allowed when "a" were being used, and vice versa to find a total of $2 \times 3 \times 4 \times 3$.

Next, Al encountered Task 14(iv): Letters abcdef, whose statement is below.

- Situation: Suppose we have the letters a, b, c, d, e, f and we are forming three-letter strings of letters ("words") from these letters.
- Question: How many 3-letters "words" can be formed from these letters if

repetition of letters is not allowed and the letter “*a*” or the letter “*d*” must be used, or both?

When presented with Task 14(iv), Al added on the number of “words” that allowed for both “*a*” and “*d*” to his solution for Task 14(iii). Since he first considered the subset for which “*a*” or “*d*” but not both could be used (the solution set to Task 14(iii)), and then considered the subset which included both “*a*” and “*d*,” his way of thinking is indicative of Addition.

He was then presented with the following alternative argument written by a supposed former student, Ian, through Devil’s Advocate. This argument was driven by Addition thinking and involves the principle of inclusion-exclusion¹:

Ian's argument for Task 14(iv): We will first count all of the “words” possible including the letter “*d*”, then all of the “words” including the letter “*a*”. Since “words” including both “*d*” and “*a*” would then be counted twice – once in each of those terms, we will subtract the number of “words” using both to compensate: If the letter “*d*” is used, then the “word” can either go $d_ _$, $_d_ _$, $_ _d$. For each of these, there are 5×4 ways to place the other letters since repetition is not allowed. So there are $3 \times 5 \times 4$ “words” with the letter “*d*”. Similarly, if the letter “*a*” is used, then there are $3 \times 5 \times 4$ ways to place the letters. If we sum these terms, we have $(3 \times 5 \times 4) + (3 \times 5 \times 4)$.

¹ The principle of inclusion-exclusion for two sets states that if A and B are finite sets, then $|A \cup B| = |A| + |B| - |A \cap B|$.

Now, if both “*a*” and “*d*” are used, we could have *ad_*, *da_*, *_ad*, *_da*, *a_d*, *d_a*.

For each of these, there are 4 “words” we can write. So there are 6×4 “words” using both “*a*” and “*d*”. Each of these has been counted twice and we only want to count it once, so we must subtract this from our above sum:

$$(3 \times 5 \times 4) + (3 \times 5 \times 4) - (6 \times 4) = 96.$$

After Al read Ian’s argument, he was presented with a sheet of paper with two overlapping circles, a disk cut out of translucent purple cellophane, and a disk cut out of translucent yellow cellophane. When he saw the sheet of paper, Al immediately said, “oh, the Venn diagram.” He stated that he had seen Venn diagrams before in English, but never in previous math classes.

The researcher then said that the purple disk represented all of the “words” including “*d*” and that the yellow disk represented the ones including “*a*.” Al said that there would be things in the overlap, but that portion was not counted in Task 14(iii). Thus, it appears as if Al could easily use the Venn diagram to connect to his Subsets thinking.

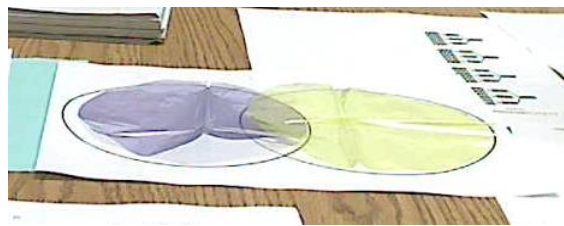

Figure 11. Two set Venn Diagram Activity from P2_S4

Al was asked to reinterpret Ian’s argument in his own words and use the manipulatives to explain the solution. After some discussion, he held up the yellow

cellophane and stated that there were $3 \times 5 \times 4$ “words” being represented by that circle, before waving the purple circle to say that there were the same number of “words” there. He placed both disks down on the paper and said that there were 6×4 “words” in the brown area which were over counted and so that amount needed to be subtracted. See Figure 11.

5.3.1.2. Three Set Venn Diagram Activity

During the fifth session of Phase 2, Al was asked to complete Task 14 (vi) whose statement is below.

- Situation: Suppose we have the letters a, b, c, d, e, f and we are forming three-letter strings of letters (“words”) from these letters.
- Question: How many 3-letters “words” can be formed from these letters if repetition of letters is allowed and the letter “ d ” must be used.

Like Kate in Section 5.2.1, Al first over counted and found that there were $36 + 36 + 36$ “words” by arguing that “ d ” could go in one of the three spaces, and for each of those options there were 6×6 ways to fill the remaining slots. First, an alternative solution driven by Deletion thinking was presented via Devil’s Advocate. This intervention is in Appendix A and is discussed in section 7.3.1.1. Al was asked to evaluate this argument and experienced perturbation because he realized that his original solution and the alternative solution could not both be correct. After some discussion, he came to find the error in his original solution. He adjusted his original solution by arguing that if “ d ” were first, there would be 6×6 or 36 ways to place the other letters. He then considered the rest of the solution set and said that if “ d ” were second, there would only

be 5×6 “words” he could count, and 5×5 “words” remaining if “ d ” were third. Since he first considered a single subset of the solution set before considering others, he engaged in Addition thinking. He did not visually represent this argument.

He was then presented with two more arguments via Devil’s Advocate, both which relied on Venn diagrams. Though Al had already resolved his perturbation and realized what he was over counting, these arguments were presented with the intention of helping him visualize his original Subsets thinking. First, he considered an argument attributed to a former student, Adam:

Adam’s argument for Task 14(vi): If “ d ” is first there are 6×6 ways to place the other letters. Now let’s think about what happens if “ d ” is second. We already counted everything that had “ d ” first, so we can’t have “ d ” first and second. Therefore, there are 5 options for the first letter and for each of them there are 6 options for the third. So there are 5×6 ways for the “ d ” to be second that we have not already counted. Finally, let’s think of what can happen if “ d ” is third. We already counted everything that had “ d ” first or second, so we can’t have “ d ” in either of those spots. So there are 5×5 ways to place “ d ” third that we have not already counted. Altogether we have $(6 \times 6) + (5 \times 6) + (5 \times 5)$ total “words”.



Figure 12. Three Set Venn Diagram Activity from P2_S5

Al was encouraged to use the translucent cellophane manipulatives provided to reinterpret Adam’s argument. This time, a sheet of paper with the overlapping circles was not provided with the intention that Al determines the alignment of the circles himself. Perhaps because his final solution to Task 14(vi) was also driven by Addition thinking, Al had no trouble describing Adam’s solution in his own words and justifying it with the Venn diagram. See Figure 12.

After Al had connected the Venn diagram with Adam’s argument, he was presented with Iuliana’s argument for Task 14(vi) which is driven by Union thinking and involves the principle of inclusion-exclusion².

Iuliana’s argument for Task 14(vi): If d is first, there are 6×6 ways to place the other letters. If it’s second, then there are 6×6 ways to place the other letters. If it is third, there are 6×6 ways to place the other letters. If we sum these terms, we get $(6 \times 6) + (6 \times 6) + (6 \times 6) = 108$ “words”.

However, this sum over-counts things of the form $dd_$ – it counts them once in the first term and once in the second, but we only want to count them once. There are 6 things of this type, so we need to subtract 6. Also, the sum over-counts things of the form d_d – it counts them once in the first term and once in the third, but we only want to count them once total. There are 6 things of this type so we need to subtract 6 from our sum. Similarly, we need to subtract 6 again because there are 6 things of the form $_dd$ which are counted twice in our sum – once in the 2nd

² The principle of inclusion-exclusion for three sets states that if A , B , and C are finite sets, then $|A \cup B \cup C| = |A| + |B| + |C| - |A \cap B| - |A \cap C| - |B \cap C| + |A \cap B \cap C|$.

term and once in the 3rd. Once we subtract, we have

$$(6 \times 6) + (6 \times 6) + (6 \times 6) - 6 - 6 - 6 = 90.$$

But notice that *ddd* is something of the form *d__* and *_d_* and *__d*. It was counted once in each term of the sum (for a total of 3 times), but we subtracted it 3 times because it is of the form *dd_*, *d_d*, and *_dd*. So it's not being counted at all in the 90 "words" we counted above. We need to add it back in:

$$(6 \times 6) + (6 \times 6) + (6 \times 6) - 6 - 6 - 6 + 1 = 91.$$

Al was again encouraged to use the translucent cellophane manipulatives provided to reinterpret Iuliana's argument. He was able to use the manipulatives to represent the subsets based on the location of *d* and indicated which intersections' sizes were being subtracted and added in Iuliana's solution.

In both the Two Set and the Three Set Venn Diagram Activity, the researcher used the PCT of Venn diagrams to connect visual images with Al's Subsets thinking. The hope was that if Al had a way to visualize such ways of thinking, he may be more attuned to the intersections in his subsets and avoid over counting.

5.3.2. Al's use of Venn diagrams

During the Venn Diagram Activity and in the following tasks, Al often used Venn diagrams as visualizations while he engaged in Subsets thinking. As described above, Al engaged in Addition thinking to determine his final solution for Task 14 (vi): Letters abcdef. At that point he did not provide any indication of how he was visualizing the relationship between the elements of the solution set, if he were in fact employing a visual image. During the Venn Diagram Activity, however, he was able to provide

justification for Adam's argument for Task 14(vi) using the Venn diagram manipulatives. Since this argument was driven by Addition thinking, it appeared as if Al could use Venn diagrams to visualize Addition thinking.

In addition, Al employed Venn diagrams to visualize his Union thinking. As an example, consider Task 16(iii): Sororities:

- Situation: A university decides that sorority names can be three-letters chosen from the following Greek letters: $\Gamma, \Delta, \Theta, \Lambda, \Pi, \Phi, \Psi, \Omega$
- Question: How many sorority names can be formed from these letters if repetition of letters is allowed and the letter " Θ " must be used.

As described above, Al engaged in Union thinking based on the location of " Θ " and found the solution to be $64 + 56 + 49$ (see Figure 10). When asked about his confidence in his solution, Al referenced doing Task 14(vi): Letters abcdef during the fifth session and immediately drew a Venn diagram (not shown) to illustrate his additive reasoning. He explained his thinking in Excerpt 6.

Excerpt 6. Task 16(iii): Sororities from P2_S6

Al: I was trying to think, ok, we have each of these different, I guess, groups of where it [Θ] can be. Like with this one I could tell that you have a group where it's the first letter, a group where it's the second letter, a group where it's the third letter (draws three overlapping circles). [...] And I knew that for all of this (indicates all of the first set), I can only count this much of this (indicates the elements in the second set excluding the first set), and I can only count this much of this (indicates the elements in the third set which have not yet been counted).

Even though Al did not draw a Venn diagram during his counting, it seems as if he may have been visualizing one from his explanation. It is clear that while he was counting, he was attending to the intersection of the subsets based on the location of Θ . The first Venn diagram Al drew was hard to read so Al drew a second one (see Figure 13) and utilized different shading techniques to show what he counted in each row of slots. In his diagram, “1st” referred to where Θ was the first letter in the “word,” and so forth.

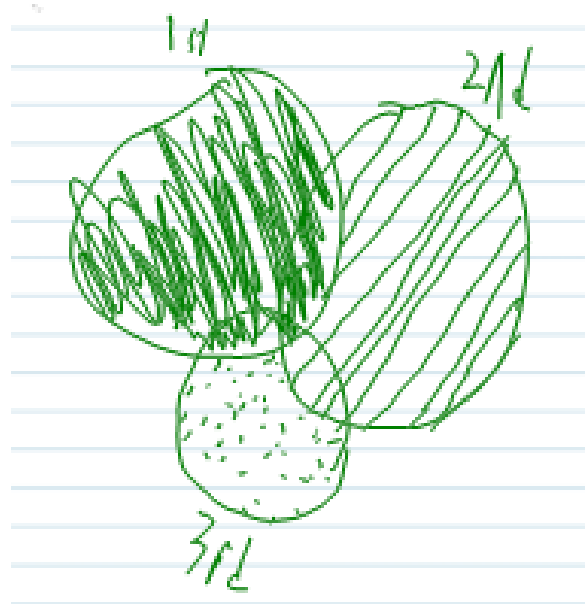

Figure 13. Al’s Venn diagram for Union thinking from Task 16(iii) in P2_S6

When Al was asked to compare his current thinking about this type of problem to his reasoning for Task 14(vi), he responded as shown in Excerpt 7.

Excerpt 7. Task 16(iii): Sororities from P2_S6

Al: Well, I think before, I would list them all, or I guess I didn’t have as clear of a way of understanding that repetitions occur in this type of problem. [...] [Here]

I'm using some way to define what these three sets are. And I'm defining [...] the first set as places where the first variable is Θ . Defining that group (points to second circle in Figure 13) as where the second variable is Θ , and that group (points to third circle) where the third variable is Θ . And by defining them, I guess I was kind of realizing that they overlap when both the first and the second requirements are met. Or when the first and the third. Or when all three are met. So by kind of knowing that the only place I'm going to have repetitions is where that's true and that's true (points to an intersection of two sets), or when all three are true, then I could kind of look for it [repetition] better.

Here, it is clear that he was visualizing this Venn diagram even though he did not originally visually represent his reasoning while solving the task. When he referred to "repetition," he was referring to the elements of the solution set which are in more than one of his subsets, not the repetition of the letters in the words. From his comparison of his thinking while solving Task 16(iii) to his thinking for Task 14(vi), it appears as if Venn diagrams helped him clearly picture what he was enumerating so that he was better able to avoid over counting while engaging in Subsets thinking.

6. ODOMETER WAYS OF THINKING

As discussed in Chapter 3, English (1991, 1993) studied young children's combinatorial strategies as they engaged in tasks involving dressing toy bears in various outfits. She found that many of the students engaged in what she termed the *odometer strategy* by holding items constant in order to generate all possible outfits. For example, a student engaging in the odometer strategy to dress a bear from a choice of 2 tops (labeled X_1, X_2 for ease), 3 pants (called Y_1, Y_2, Y_3), and 2 tennis racquets (called Z_1, Z_2) could match each of the tops with each of the pants, and match each of these pairs in turn with each of the tennis racquets. Indeed, the student could dress the bears first in (X_1, Y_1, Z_1) then maintain the tops and pants while changing the tennis racquet: (X_1, Y_1, Z_2) . Upon exhaustion of the racquets, the student could change the pants, while maintaining the color of the top.

Notice that while the odometer strategy provides a mechanism for students to systematically list all elements of their solution set, it is not clear whether the students implementing the odometer strategy are able to *anticipate* the result of implementation. Indeed, the students may truly be implementing a strategy, or a goal-directed mental operation to facilitate the completion of the task (Bjorklund, 1990), not engaging in a way of thinking which allowed them to reason about the elements of the solution set and their relationships to one another.. In addition, the students were constructing elements of the solution set, not being asked to determine the number of elements of the solution set. Certainly the size of the solution set can be determined by counting the number of

elements generated by the implementation of the odometer strategy, but this is not practical for large solution sets.

This research extends the odometer strategy (English, 1991, 1993) by examining the ways of thinking in which students engage as they mentally hold items constant in order to count the size of solution sets. In particular, this chapter discusses the ways of thinking belonging to the Odometer category of the final framework of ways of thinking. First, it presents characterizations and examples of the three ways of thinking in this category: Standard Odometer, Wacky Odometer, and Generalized Odometer. Next, it discusses relationships between ways of thinking in the Odometer category, and finally presents the visual images used by the students to represent Odometer thinking.

6.1. Odometer Ways of Thinking from the Framework

In this study, three ways of thinking were identified as robust and together comprise the Odometer category. Students engage in ways of thinking belonging to this category as they hold an item or sets of items constant while systematically varying the other items. The three ways of thinking in this category are labeled as Standard Odometer, Wacky Odometer, and Generalized Odometer, respectively. These ways of thinking are summarized in Table 11. The subsections below provide characterizations of each way of thinking in this category, along with examples of students engaging in each.

Essentially, students engaging in any of the Odometer ways of thinking could organize the elements of the solution set in a tree diagram (or table in the two-dimensional case) and could anticipate how the branches and leaves of the trees would be determined. This means that they were not simply implementing a strategy, but rather,

they were aware of relationships between elements of the solution set. It is important to note that though these students might have been able to *organize* the elements in the manner a tree diagram might, this does not mean that the students were *visualizing* a tree diagram. Visual representations of Odometer thinking will be discussed in Section 6.3 below.

Table 11. Odometer ways of thinking

Category	Way of Thinking	Characterization
Odometer	Standard Odometer	First, determine the number of items which could be placed into a given position. Then, for each of those placements, determine the number of ways to place items in the other positions in an effort to construct the entire solution set.
	Wacky Odometer	First, determine the number of positions in which a given item could be placed. Then, for each of those placements, determine the number of ways to place items in the other positions in an effort to construct the entire solution set.
	Generalized Odometer	First, select a set of items to be held constant. Next, determine the number of ways to place these items in slots. Third, for each of those placements, systematically vary items in the other slots in an effort to construct the entire solution set and determine its size.

6.1.1. Standard Odometer

One way of thinking which involves holding something constant was present in the data when students held items constant in a given position. This is called *Standard Odometer* in this study. Consider Task 8(i): Fraternities.

- Situation: There are 24 letters in the Greek alphabet. Fraternity names involve 3 Greek letters.

- Question: How many fraternities may be specified by choosing 3 Greek letters if repetitions are not allowed?

When Al encountered this task in the third session of Phase 2, his first inclination was to draw three boxes. They were too small for him to write inside of them, so he re-drew them and responded as shown in Excerpt 8.

Excerpt 8. Task 8(i): Fraternities from P2_S3

Al: In the first box [...] you could either have letter one through twenty four [Writes 1-24 in first box]. But for the second you'd only have twenty three different possibilities (writes 23 in second box) and for the third you'd only have twenty two different possibilities (writes 22 in third box) [...]. So [...] you'd have twenty four different possible first letters (writes 24) and then for each one you'd have twenty three (writes 23) and for each of those you'd have twenty two (writes 22) so just multiply all those numbers together. (Inserts \times between numbers).

In Excerpt 8, Al used boxes instead of slots to represent the three letters in the Fraternity name. He seemed to have renamed the Greek letters as the “letters” 1-24 and determined that all of these could go in the first slot. He then determined that there were 23 possibilities for the second slot, and 22 for the third. He explained that the solution would be $24 \times 23 \times 22$ by saying that “*for each one* [of the twenty four possible first letters], you’d have 23 [possibilities for the second letter].” This indicates that he was considering each of the possible 24 first letters, and holding them constant. He varied the other items in the second box to determine that there were 23 possibilities for the next letter. He finished by determining that there were 22 possibilities for the last box.

Standard Odometer thinking entails the following mental acts: First determine the number of items which could be placed into a given position. Then, for each of those placements, determine the number of ways to place items in the other positions until the entire solution set had been constructed. Once a student engaging in Standard Odometer has determined the number of items which could be placed in a given position, he or she could essentially hold items constant in that given position while systematically varying the other items. The idea of holding something constant and systematically varying items is consistent with the odometer strategy from English (1991).

In Al's case in Excerpt 8, the "given" position was the first position. He determined that there were 24 items to be held in that given position, and then determined the number of ways the remaining items could be placed in the other slots. Notice that Al's explanation in Excerpt 8 could impose a structure of the elements of the solution set. Indeed, his way of thinking is analogous to the construction of a tree diagram with 24 trees. The roots of the trees would be of the form $X _ _$, where X is a Greek Letter. There would be 23 branches off of each root based on the items placed in the second position, and there would be 22 leaves off of each of those based off of the item in the last position. The order of the leaves of the tree diagram would impose an order on the elements of the solution set. See Figure 14 for a partial tree diagram which could model Al's Standard Odometer thinking for Task 8(i). Not all of the vertices in the tree with root A are listed in Figure 14.

From Al's utterances in Excerpt 8, there is no evidence that he was visualizing a tree diagram. Nevertheless, his way of thinking shows that the elements of the solution set could be organized in the manner that a tree diagram would. A deeper discussion of

the relationship between Odometer thinking and tree diagrams as its visualization is in Section 6.3 below.

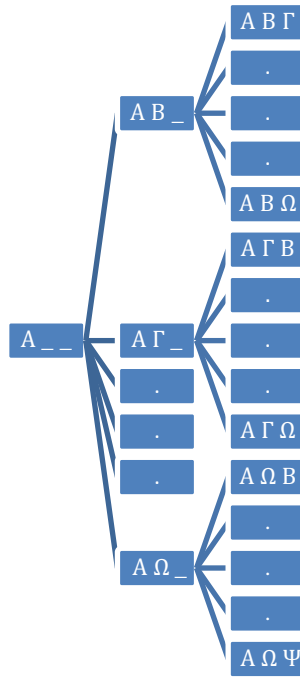

Figure 14. Partial tree diagram modeling AI's Standard Odometer thinking

Kate, Boris, AI, and many students from the pilot studies engaged in Standard Odometer thinking for numerous tasks. Therefore, Standard Odometer satisfies the applicability criterion of robust ways of thinking. In addition, students engaging in Standard Odometer reasoned about relationships between elements of the solution set – they could see how the elements of the solution set are grouped based on the item being held constant. Thus, Standard Odometer has a strong cognitive root as well, and is therefore a robust way of thinking.

6.1.2. Wacky Odometer

When engaging in Standard Odometer thinking, a student holds items constant in a given position before varying items in the other positions – the focus is on the position. In contrast, a student could hold a single item constant in different positions before varying items in other positions – the focus now is on the item. This is a characteristic of a way of thinking which is called *Wacky Odometer* in this study. Consider Task 14(ii):

Letters abcd f :

- Situation: Suppose we have the letters a, b, c, d, e, f and we are forming three-letter strings of letters (“words”) from these letters.
- Question: How many 3-letters “words” can be formed from these letters if repetition of letters is not allowed and the letter “ d ” must be used?

Kate and Boris encountered this task in the second paired session of Phase 1.

Kate’s solution is shown in the following excerpt.

Excerpt 9. Task 14(ii): Letters abcd f from P1_PS2

Kate: I was just putting the “ d ” in different slots and then thinking of the options when “ d ” was in that slot. So when “ d ” was the first letter, [...] there are five options for the second letter and four options for the third letter. And then when “ d ” is the second letter, there's another five times four. And when “ d ” is the third letter there's another five times four. [...] Which would end up being five times four times three – which would be sixty.

In Excerpt 9, Kate’s solution is driven by the location of the item “*d*” which can be placed in three different slots. For each of those three placements, Kate determined that there were 5×4 ways to place items in the other positions.

Wacky Odometer thinking entails the following mental acts: First determine the number of positions in which a given item could be placed. Then, for each of those placements, determine the number of ways to place items in the other positions until the entire solution set had been constructed. Once a student engaging in Wacky Odometer thinking has determined the number of positions in which a given item could be placed, he or she could hold the item constant in these positions while systematically varying items in the other slots. Again, the idea of holding something constant and systematically varying items is consistent with the odometer strategy from English (1991).

In Kate’s solution above, the given item was the letter “*d*.” She determined first that “*d*” could be placed in three different slots, and then, for each of those placements, considered the remaining items and positions. Thus, it appears as if she engaged in Wacky Odometer thinking in Excerpt 9.

For clarity of the distinction between Standard and Wacky Odometer, consider the following problem of determining the number of permutations of {A, B, C, D}, and solutions driven by the different ways of thinking.

Solution 1 driven by Standard Odometer thinking: We have options based on what goes in the first slot and then we can fill the other slots. First, there are 4 items that can go in the first slot. Now we can hold them constant and determine how to fill the other slots. For each one of them, there are 3 items that can go in the

second slot (if A is first, we have B , C and D as options for the second slot). For each of those, there are 2 items that can go in the third slot (so if we have $AB_ _$, C or D could go in the third slot), and finally just 1 item that can go in the fourth slot. Therefore, we have $4 \times 3 \times 2 \times 1$ total permutations, which can be seen from the tree diagram in Figure 15 below.

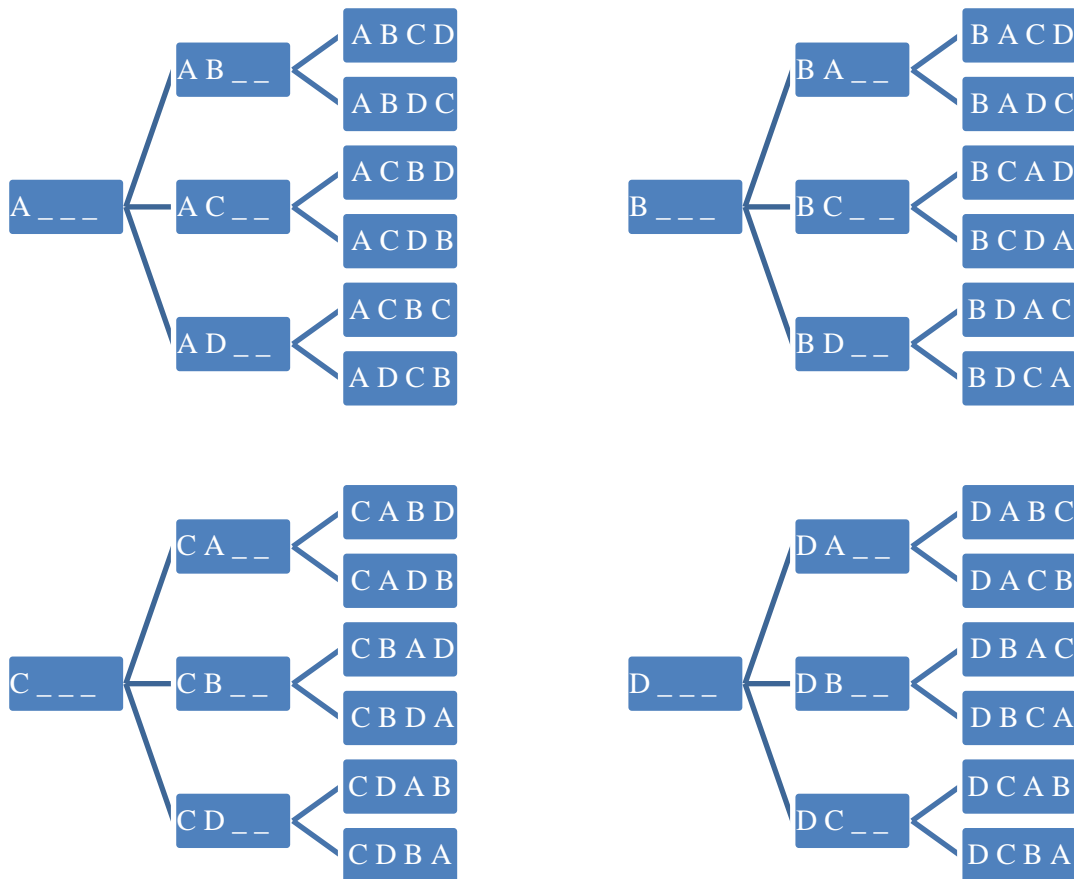

Figure 15. Standard Odometer thinking for permuting $\{A, B, C, D\}$

Solution 2 driven by Wacky Odometer thinking: We have options based on where A goes and then hold that constant to determine the ways to place the other letters. First, A can go in 4 different slots. We can place it and hold it constant while we determine how to fill the other slots. For each placement of A , there are 3 slots in

which B could be placed. For each of those, there are 2 ways to place the C .

Finally, for each of those placements, there is only 1 ways to place the D . So there

are $4 \times 3 \times 2 \times 1$ total permutations. This creates the tree diagram in Figure 16

below.

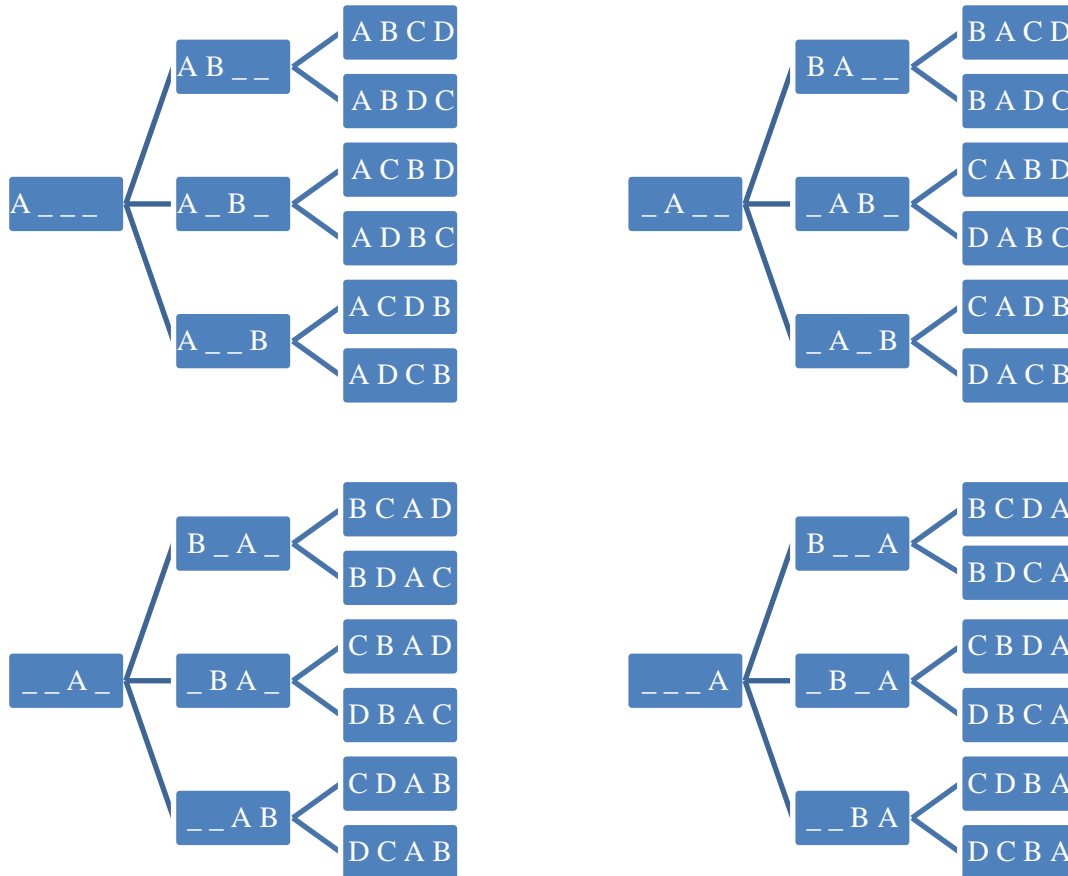

Figure 16. Wacky Odometer thinking for permuting $\{A, B, C, D\}$

Notice that in the first solution visualized in Figure 15, items are being held constant in the first slot and the other items are varied. In contrast, in the second solution visualized in Figure 16, item A is held constant in different slots while the other items are varied. In both solutions, items are being held constant, which is the hallmark of Odometer thinking. These examples show how tree diagrams are a visual image which

could be associated with Standard and Wacky Odometer. Again, students engaging in Odometer thinking may not be visualizing tree diagrams even when they can organize the elements of the solution set in the same manner a tree diagram would.

Kate, Boris, Al, and many students from the pilot studies engaged in Wacky Odometer thinking for several tasks. Therefore, Wacky Odometer satisfies the applicability criterion of robust ways of thinking. In addition, students engaging in Wacky Odometer reasoned about relationships between elements of the solution set – they could see how the elements of the solution set are grouped based on the item being held constant. Thus, Wacky Odometer has a strong cognitive root and is a robust way of thinking.

6.1.3. Generalized Odometer

Instead of holding items constant in a given position (Standard Odometer), or holding a given item constant in various positions (Wacky Odometer), some students were able to determine a set of items to be held constant in various positions. This way of thinking is called *Generalized Odometer* in this study and was discussed in 2.3.1.1.

Consider Task 29: Cards:

- Situation: Each one of five cards has a letter: A, B, C, C, and C.
- Question: In how many different ways can I form a row by placing the five cards on the table?

Boris and Kate encountered this task in the fifth paired session of Phase 1. After the students were given a few seconds to think about the task on their own, Boris shared his thoughts first.

Excerpt 10. Task 29: Cards from P1_PS5

Boris: I guess I was thinking about different ways you could put the C's down. Since you have five spots, it would be how many different ways you could pick three of those spots from the five. So that would be five choose three. And then the number of ways that you could place the last two letters would be two factorial. So it [the solution] would be really five choose three times two.

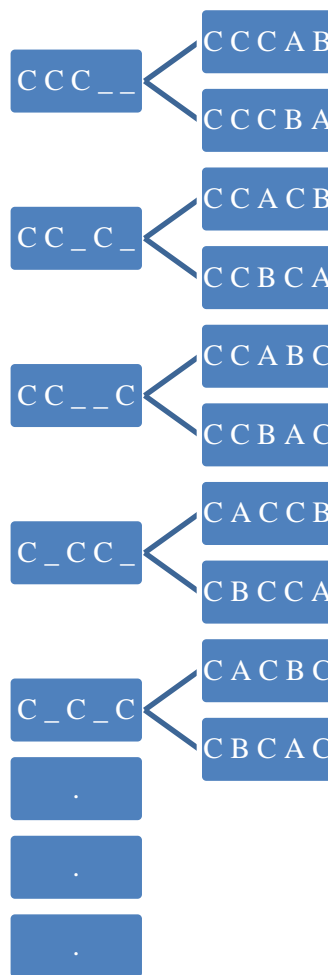

Figure 17. Partial tree diagram modeling Boris' Generalized Odometer thinking

In Excerpt 10, Boris viewed elements of the solution set as having five spots. He first considered the number of ways to place the three C's down, which was equivalent to choosing three of the five spots for the C's. He then stated that there would be $2!$ ways to place the other letters in the other spots. His solution was $\binom{5}{3} \times 2$. His multiplication indicates that for *each* of the $\binom{5}{3}$ placements of the C's, he knew that there $2!$ ways to place the other letters. Boris' reasoning can be modeled as shown in Figure 17. The $\binom{5}{3}$ roots of these trees contain a placement of the set of Cs, and the leaves contain elements of the solution set. Boris' approach to this task is indicative of what will be called "Generalized Odometer" thinking.

Generalized Odometer thinking entails the following mental acts: First, select a set of items to be held constant. Next, determine the number of ways to place these items in slots. Third, for each of those placements, systematically vary items in the other slots in order to determine the number of elements in the entire solution set. Once again, after a student has determined the number of ways to place the set of items in slots, the student can hold this set of items constant in the different positions while systematically varying items in the other slots. The idea of holding something constant and systematically varying other items in Generalized Odometer is consistent with the odometer strategy (English, 1991). Generalized Odometer differs from Standard and Wacky Odometer thinking because it requires that a set of items be placed at a time, rather than a single item as both Standard and Wacky Odometer require.

The three students from this study and both students in Pilot Study 2 engaged in Generalized Odometer thinking for numerous tasks. Therefore, Generalized Odometer satisfies the applicability criterion of robust ways of thinking. In addition, students engaging in Generalized Odometer reasoned about relationships between elements of the solution set – they could see how the elements of the solution set are grouped based on the set of items being held constant. Thus, Generalized Odometer has a strong cognitive root and is a robust way of thinking.

6.2. Relationships between Odometer Ways of Thinking

All three Odometer ways of thinking involve holding an item or set of items constant while systematically varying the other items. Thus, they are similar to the odometer strategy identified by English (1991). However, unlike the odometer strategy, Standard Odometer, Wacky Odometer, and Generalized Odometer are all *ways of thinking* about the elements of the solution set, not simply strategies for generating elements of the solution set. In that sense, they extend the odometer strategy.

In all three Odometer ways of thinking, the student would first figure out the number of ways to place either multiple items in a particular place, the same item in various places, or set of items in various places. For each of those original placements, the student would determine the number of ways to place items in the other positions. Often, after the first step of placing original items, the number of ways to place the items in the other positions is the same for each of the original placements. For example, a student permuting {A, B, C, D} could determine there were four ways to place a letter in the first slot. Then, for each one of the letters placed in the first slot, she might determine that there are 6 ways to place the other letters. In cases such as this, the size of the

solution set can be determined by multiplying the number of original placements with the number of ways to vary the other items. Therefore, the operation of multiplication in a final expression for the size of a solution set often indicates that an Odometer way of thinking could have driven the solution. However, Odometer thinking could drive a solution whose final expression might not involve the operation of multiplication. Indeed, the student permuting {A, B, C, D} could either report the final expression as 4×6 or $6 + 6 + 6 + 6$.

One difference between the various Odometer ways of thinking comes from whether an item or a set of items is being held constant. When engaging in *Standard Odometer* and *Wacky Odometer*, the student places an item and holds it constant; in contrast, in *Generalized Odometer*, the student places a set of items and holds it constant. Another difference between the Odometer ways of thinking is whether the student's focus is on items or positions. In *Standard Odometer*, the focus is on a given position – the student would hold items constant in that given position and, for each of those placements, vary the items for the other positions. In *Wacky Odometer*, the focus is instead on a given item – the student would hold the item constant in different positions and, for each of those placements, vary the other items in the other positions. In *Generalized Odometer*, the focus is on a set of items and the ways in which these items could be placed.

6.3. Visualizations of Odometer Thinking

This Section discusses the visual images students used for Odometer thinking. The first visual representation, tables, was used spontaneously by students and was also encouraged through instructional interventions. The second, tree diagrams, was used

spontaneously by AI and was also encouraged through instructional interventions. During Phase 1, students seemed confused initially when the tree diagram was introduced. However, they later employed a slightly different version of a tree diagram themselves.

6.3.1. Tables

As mentioned previously, Odometer thinking imposes a structure on the elements of a solution set. One way this structure could be visualized in the case of two-dimensional arrangement problems is through the use of tables. The following subsections describe a student's spontaneous use of tables in Pilot Study 1, the introduction of tables in this study through instructional interventions, and AI's use of tables in other tasks following the introduction of the visual representation.

6.3.1.1. Student spontaneous use of tables

Consider Task 2: Dice whose statement is below.

- Situation: Two dice are rolled, one red and one white.
- Question: How many possible outcomes are there that are not doubles?

When Tom received the situation of the dice problem in Pilot Study 1 and realized it likely involved counting rolls of the dice, he immediately answered, "You have like 36." The researcher asked what he meant, and he responded as shown in Excerpt 11.

Excerpt 11. Task 2: Dice from Pilot Study 1

Tom: I can put one here [holds the red die at one] and there are 6 [indicates the 6 sides for the white die]. And then you can change to two [changes the red die to two] and put it with 6 (sides).

This seems like evidence of the Standard Odometer way of thinking for determining the number of total possible outcomes. In fact, Tom's explanation in Excerpt 11 seems indicative of the odometer strategy: He held the red die constant at a particular value while varying the values for the white die; he then changed the value on the red die and again varied the white die. However, it appeared as if he could anticipate that there will be six values on the white die for each of the six values on the red die, which is supported by his immediate solution of $6 \times 6 = 36$. Thus, he was engaging in a way of thinking, not simply implementing the odometer strategy.

When pressed to explain further, he created the table in Figure 18, writing "1=2" to represent the roll that has a red 1 and a white 2. The researcher then initiated a discussion about whether a red 1 and white 2 was the same outcome as a red 2 and white 1. Tom first believed that this would be true (this explains the crossing out in the figure) but then realized that he was originally correct. The researcher then presented Tom with the actual question. He immediately determined the answer to be 30 and explained that we do not need "1=1", "2=2", "3=3", "4=4", "5=5", or "6=6", so it would be $36 - 6 = 30$.

(1=1)	(1=2)	(1=3)	(1=4)	(1=5)	(1=6)
(2=1)	(2=2)	(2=3)	(2=4)	(2=5)	(2=6)
(3=1)	(3=2)	(3=3)	(3=4)	(3=5)	(3=6)
(4=1)	(4=2)	(4=3)	(4=4)	(4=5)	(4=6)
(5=1)	(5=2)	(5=3)	(5=4)	(5=5)	(5=6)
(6=1)	(6=2)	(6=3)	(6=4)	(6=5)	(6=6)

Figure 18. Tom's table for Standard Odometer thinking in the Dice problem

Tom's visualization of his Odometer thinking involved constructing a table which organized the elements of the solution set by the number on each die. Each row consists of elements of the solution set which have the same number on the red die, and each column consists of elements which have the same number on the white die. The way this table is organized means that it is easy to anticipate where a particular element would be located. For example, the roll (5=3), which has a 5 on the red die and a 3 on the white die, would be in the fifth row because the rows are organized by the red die number. The element (5 = 3) would be in the third column because the columns are organized by the white die number.

6.3.1.2. Introduction of tables through instruction

Visualization of Odometer thinking was encouraged through the use of tables, a PCT, and implemented through Devil's Advocate during this study. Consider Task 4: 2-digit number whose statement is below.

- Situation: A 2-digit number is a number formed by taking an integer from 1-9 and appending an integer from 0-9.
- Question: How many 2-digit numbers are there?

When Al saw this question in the first individual interview of Phase 2, he reasoned that the highest possible 2-digit number was 99. He claimed that he needed to subtract the lowest 2-digit number, 10, from 99 in order to find the total number of 2-digit numbers since he knew that "every number in between them [10 and 99] also exists." He was then presented with Karl's argument through Devil's Advocate. This argument is driven by Standard Odometer thinking. Indeed, it begins by implementing the odometer strategy to generate elements of the solution set. However, it does not complete the

odometer strategy, leaving several blanks in the table. Instead, it anticipates the results of implementing such a strategy to completion and provides a way to organize the elements of the solution set. This anticipation of results means that “Karl” was engaging in a way of thinking (Standard Odometer, in this case), not simply implementing a strategy.

Karl’s argument for Task 4: First, we can hold a 1 constant in the 10’s place and cycle through the possibilities for the 1’s place. Then, we can hold a 2 constant in the 10’s place and cycle through the possibilities for the 1’s place. Continuing this process, we can organize the elements in the following manner.

10	20	30	40	50	60	70	80	90
11								
12								
13								
14								
15								
16								
17								
18								
19								

Al called the table in Karl’s argument a “chart” and recreated it on his paper. Excerpt 12 shows that Al interpreted Karl’s argument as “counting” the elements 10 through 99.

Excerpt 12. Task 4: 2-digit numbers from P2_III

Al: Basically he [Karl] was counting 10 to 99.

Aviva: So where would 99 be in this chart?

Al: The 99 would be at the bottom right.

In the excerpt above, Al demonstrated that he could anticipate the location of an element of the solution set in the table, which indicates that he was engaging in Standard Odometer to understand Karl's argument. Indeed, Al needed to understand the organization of the elements imposed by Standard Odometer in order to place an isolated element in the table. The conjecture that he engaged in Standard Odometer is further supported by the fact that he next said that the chart could be extended so that a 0 could be written to the left of the first row since the second digit in the elements there was zero, a 1 could be written to the left of the second row since the second digit in the elements there was 1, etc. Again, this shows that he understood how the chart was organizing the elements of the solution set, which indicates that he was engaging in Standard Odometer.

After demonstrating showing that he could engage in Standard Odometer to understand Karl's argument, Al experienced a perturbation when he multiplied the number of rows and columns in Karl's argument and realized that Karl would get 90, a different answer from Al's previous solution. He resolved this perturbation by recognizing that he should have subtracted 9 from 99 since there are 99 numbers from 1 to 99, but that the numbers 1 through 9 should not be counted. It appears as if the table in Karl's argument helped Al recognize and address his error.

6.3.1.3. Student subsequent use of tables

After the paired session in Phase 2, Al was asked to complete Task 7: Balls as homework. The statement of the task is below.

- Situation: Suppose a store has a bin with 5 indistinguishable tennis balls and 8 indistinguishable golf balls.

- Question: In how many ways can I buy at least one ball from this store?

In his reflection following the paired session from Phase 2, Al included a solution to this task, shown in Figure 19.

This problem is asking for how many ways could you purchase 1 to 13 balls. The limitation however is that because each kind of ball is identical to others of the same type as it. This means that buying tennis ball 1 and tennis ball 2 is the same as buying tennis ball 1 and tennis ball 3, eliminating several possibilities.

This means that any purchase includes 0 through 5 tennis balls and 0 through 8 golf balls, with at least one ball being purchased. This can be charted through the following chart:

Number of Tennis balls	Number of golf balls
0	1-8
1	0-8
2	0-8
3	0-8
4	0-8
5	0-8

So to find the answer you find $1 \times 8 + 5 \times 9$

So the answer is 53

Figure 19. Al's solution for Task 7: Balls

Notice that in Al's solution in Figure 19, the first column of his chart has only one number, while the second column contains a range of numbers. Thus, he was pairing each option of a tennis ball purchase with all possible options of the golf ball purchase. This is indicative of Standard Odometer thinking.

It is interesting to note that Al's visual representation of his Standard Odometer thinking in Figure 19 is different from the chart presented in Karl's argument to represent Standard Odometer thinking. In Al's visual image, there are only two columns – the first column corresponds to items in the first slot, the second column gives the number of possibilities of items in the second slot. In Karl's, there were as many columns as there were items for the second slot. In Al's representation, an element of the solution set can be formed by taking the item in the first column and pairing it with an item in the range of the second column in the same row. For example, the number 0 from the first column could be paired with the number 5 since 5 is between 1 and 8, the range listed in the second column of that same row. The pairing (0, 5) would correspond to a purchase of 0 tennis balls and 5 golf balls. In contrast, Karl's table contained all elements of the solution set.

6.3.2. Tree diagrams

Another visual representation for Odometer thinking is tree diagrams. Examples of tree diagrams as visual images associated with Odometer thinking can be found in Section 6.1 above. The subsections below provide examples of Al's spontaneous use of tree diagrams in the second phase, the way in which tree diagrams were introduced in this study through instructional interventions, and Boris and Kate's transfer of tree diagrams to other problems following the introduction of the representation. These subsections focus on the use of tree diagrams to visualize Standard Odometer thinking. However, as shown in Figure 16 and Figure 17, tree diagrams can also be used to visualize Wacky and Generalized Odometer, respectively.

6.3.2.1. Student spontaneous use of tree diagrams

During the first individual interview of Phase 2, Al engaged in Disney thinking for Task 1: Mississippi I in an effort to permute the letters in MISSISSIPPI. The statement of the task is below.

- Situation: Imagine that the state of Mississippi is adopting new, 11-character license plates. For fun, the state agreed to provide citizens who use the letters in the word “MISSISSIPPI” arranged in any order with a special license plate with an image of the mockingbird (the Mississippi state bird) as the background.
- Question: How many of these special license plates with the mockingbird must the state be prepared create?

He stated that he was having trouble with finding a specific answer to Task 1, so the researcher asked if he could think of an easier version of the problem. Al chose to work with a four-letter license plate with the letters MIPS:

Excerpt 13. Variation of Task 1: Mississippi I from P2_III

Al: You could get Sections where there would be sets of words that start with M (writes M on the left in Figure 20), start with I (writes I on the left in Figure 20), start with P (writes P on the left in Figure 20), or that start with S (writes S on the left in Figure 20). And then for sets that start with M, I could break that up into maybe two Sections (draws two branches off of M in Figure 20) [...] that start with.... Or three Sections (adds an additional branch off of M in Figure 20) that start with I, start with P, start with S (writes these as he says them). And then I

could break that I into two Sections (draws two branches off of the I at the top of Figure 20), maybe, where I would have this letter is P and the next letter is S (writes these letters off the branches he indicated). And then P where the next letter is I and S (draws two branches off of the P in the second level, and writes I and S off of them in Figure 20). And then S and I P (draws two branches off of the S in the second level, and writes I and P off of them in Figure 20). And so we'd have say, for this one [sets that start with M] you could have 1, 2, 3, 4, 5, 6 (draws ticks shown in grey off of each leaf he has in the tree with root M) for that one [sets that start with M], six for this one [sets that start with I] (draws a tick off of the I below the tree with root M, shown in grey in Figure 20), six for this one [sets that start with P] (draws a tick off of the P below the tree with root M, shown in grey in Figure 20), six for this one [sets that start with S] (draws a tick off of the S below the tree with root M, shown in grey in Figure 20). So there would be twenty four [license plates].

In Excerpt 13, it appears as if Al first considered the number of options for the first slot in the 4-letter license plate, and determined that there were four of these options. This partitions the solution set of permutations of MIPS into four subsets based on the criterion of the letter in the first slot. He then attempted to determine the size of the subset containing elements beginning with M. He determined that there were three possibilities for the second slot, and that for each of them, there were two possibilities for the third slot. He did not verbalize it, but it is likely he recognized that for each of those placements, there was only one option for the fourth slot. This conjecture is supported by the fact that he viewed his counting as complete for the subset containing elements

beginning with M and moved on to determining the number of elements in the whole solution set. Thus, it appeared as if Standard Odometer was a driving force behind his solution.

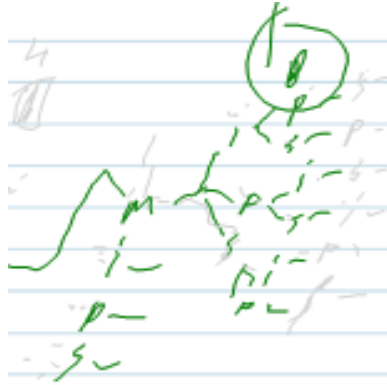

Figure 20. Al's tree diagram for permuting MISP through Standard Odometer

Al visualized his Standard Odometer thinking using a tree diagram in Figure 20, which he created as he was explaining his solution to permute MISP in Excerpt 13. Al drew a tree diagram with four roots – one for each letter which could be placed in the first slot. He then filled out the branches for the tree with root M. When asked to explain further, Al inserted a leaf off of each of the branches in the tree with root M (shown in grey in Figure 20). While examining his tree diagram, he stated that the license plate could be MIPS, MISP, MPIS, MPSI, MSIP, or MSPI. Thus, it appeared as if Al was visualizing elements of the solution set through his tree diagram in Figure 20.

Notice that elements of the subset containing license plates beginning with M can be determined by following a path from root to leaf in the tree with root M. There is thus an inherent order to the elements of the solution set based on the order of the leaves from top to bottom in the tree. Indeed, the leaf with an S is at the top of the tree diagram in

Figure 20, and the path that leads to S corresponds to the element MIPS. In Figure 20, P is the leaf just below S, and the path that leads to this element is MISP. In fact, AI read out the elements of the solution set in this order.

The researcher asked AI if he had ever seen tree diagrams before. His response is in Excerpt 14.

Excerpt 14. Variation of Task 1: Mississippi I in P2_III

AI: I kind of made it up [...] based on almost the old number trees that you see in algebra. Where say twenty seven and then you could branch it out into (Writes "27" with two branches off of it in Figure 21).

Aviva: The factor tree?

AI: Yeah the factor tree. So you could do like 3 times 9 (writes "3" and "9" off of the branches in Figure 21) or 9 would be 3 times 3 (draws branches off of the "9" in Figure 21 and writes "3" and "9" off of the branches). I just kind of thought you're breaking it up that way just as a way of taking something very big and breaking it up into smaller things [...]. Because I realized that if I was just going to try and count all of these in my head, or write each one out it would take a while and I might miss one and then this one would be really difficult to check. But if I were to break it up into, ok, there can only be four possible first ones then I could kind of break it up into sections and tackle it that way.



Figure 21. Al's factor tree

From Excerpt 14, it is clear that Al had no prior experience with tree diagrams for counting problems. It appears as if he made a connection between the idea of partitioning the solution set based on the first item in an element of the solution set and the idea of “breaking [...] up” 27 into its factors. Thus, from an actor-oriented perspective (Lobato & Siebert, 2002), Al transferred the visual representation of trees from prime factorization to combinatorics, a completely different domain.

6.3.2.2. Introduction of tree diagram through instruction

During the second paired session of Phase 1, the PCT of tree diagrams were introduced through Devil's Advocate for Task 11: Grandma, Bat 6, D. This task has a distribution ICM (D) and was adapted from the 6th question in Batanero et al.'s (1997b) questionnaire. The statement of Task 11 is below.

- Situation: Four children: Alice, Bert, Carol, and Diana go to spend the night at their grandmother's home. She has two different rooms available (one on the ground floor and another upstairs) in which she could place all or some of the children to sleep.

- Question: In how many different ways can the grandmother place the children in the two different rooms?

Kate engaged in Addition thinking to determine an answer of 15 by first considering the possible people Alice could be grouped with in one room and physically listing out elements of the solution set, as shown in Figure 22. Here, ‘A’ refers to Alice being in the room by herself, ‘AB’ refers to Alice being in this room with Bert, etc. The 0 at the bottom left corner of Figure 22 refers to no students being in this room.

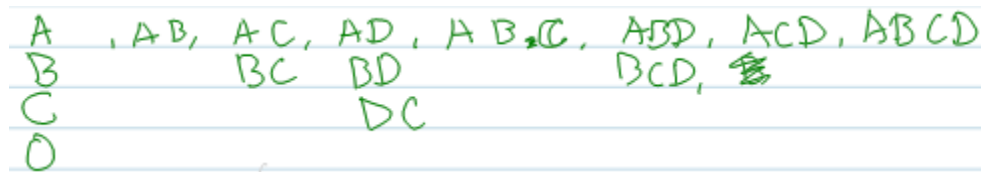

Figure 22. Kate’s list of elements for Task 11: Grandma

On the other hand, Boris determined the answer to be 2^4 , explaining that there were two rooms that the first person could go to, for each of those possibilities, there were two possibilities for where the second person could go, and so forth. It appears as if his argument was driven by Standard Odometer. The researcher asked the students to reinterpret each other’s solutions, and the students experienced a perturbation since their numerical solutions were not the same. Together the students realized that Kate had forgotten to list the element D in Figure 22.

Then, the researcher implemented Devil’s Advocate by providing the tree diagram shown in Figure 23 as a solution provided by a supposed former student, Annette. The intention of this intervention was to use the PCT of tree-diagrams to connect to students’ Odometer thinking. At first Kate was confused by the representation

and stated, “I don’t even know what that means.” On the other hand, Boris, after examining the tree diagram for several seconds, responded as shown in Excerpt 15.

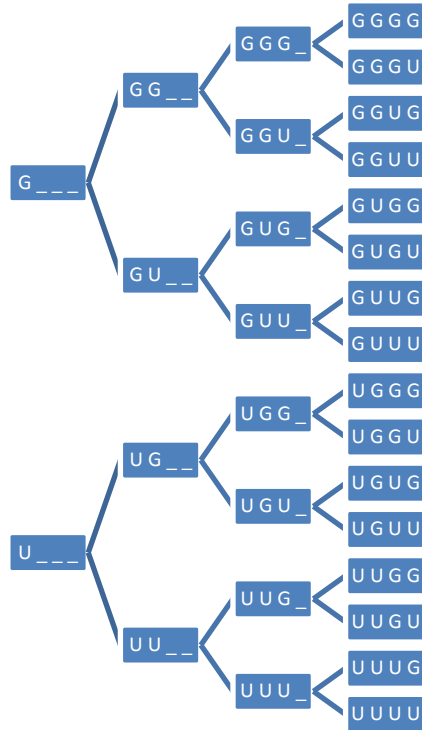

Figure 23. “Annette’s Solution” for Task 11: Grandma

Excerpt 15. Task 11: Grandma from P1_PS2

Boris: So I guess it's like doing it per person. [...] She [is] pulling it apart like one person at a time. For the first person, they can either go to the ground floor or the upper floor. So like, you hold one constant. Say the first [person] goes to the ground floor. [...] And then the next person could go to the ground floor or the upper floor. So then, they both go to the ground floor for those [...] four possibilities (points to the top four leaves of the tree). After that point (points to the vertex G G _ _) they [the third person] can go to the ground floor or the upper

floor. So if they go to the ground floor [...] and again there are two more possibilities for each of those. So there's two more there.

In Excerpt 15, it seems as if Boris had made a connection between Annette's solution and the idea of holding something constant. In other words, he could see that Annette's solution was driven by Standard Odometer thinking and could articulate how such reasoning could create the tree diagram in Figure 23. Following Boris' interpretation of Annette's solution, Kate immediately responded, "so this is just a graphic representation of what you [Boris] were saying." This indicates that despite the fact that Kate originally experienced some perturbation and could not make sense of the tree diagram at first, she was also able to recognize that Annette's visualization was driven by Standard Odometer and connect it to Boris' original solution, which was also driven by Standard Odometer. Though Al in Phase 2 spontaneously created tree diagrams as a visual representation of his Odometer thinking, the visual representation seemed to have caused some perturbation for Kate in Phase 1.

Later in Phase 1, Kate and Boris had additional opportunities to work with tree diagrams in Tasks 12: Lotto, Bat 11, S (see Appendix for details). In this task, they were presented with a partial tree diagram (see Figure 24) which was driven by Standard Odometer. The students were asked to determine what would be written at a given vertex. The fact that they could quickly do so indicates that both students were able to recognize the structure that Standard Odometer imposed on the solution set.

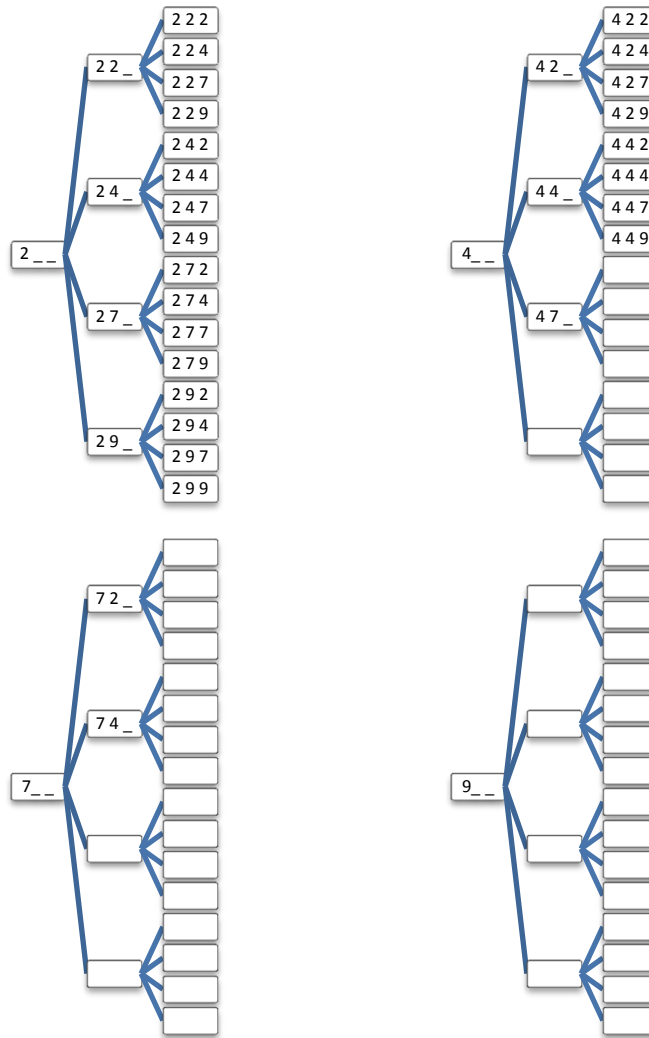

Figure 24. “Toni’s solution” to Task 12: Lotto

6.3.2.3. Student subsequent use of tree diagrams

Kate and Boris each used tree diagrams as a visual representation of their Standard Odometer thinking in the second paired session of Phase 1. It is interesting that their representations were different from the ones presented to them in Figure 23 and Figure 24. An example of each student’s resulting tree diagram is in the subsections below.

6.3.2.3.1. Kate's use of tree diagrams

Consider Task 13: Committee 2, Bat 13, S, which has a Selection ICM (S) and was adapted from Batanero et al's (1997b) questionnaire. The statement of Task 13 is below:

- Situation: A club needs a three member committee (president, treasurer, and secretary), and has 4 candidates (Arthur, Ben, Charles, and David).
- Question: How many different committees could be selected?

Kate and Boris determined that there were $4 \times 3 \times 2$ committees and were asked to “graphically represent” their solution in the way that Annette (Figure 23) and Toni (Figure 24) had. Kate was writing at that point, and created her version of tree diagram which is in Figure 25. The 4^3 in the top left of the figure is from the previous task and should be ignored.

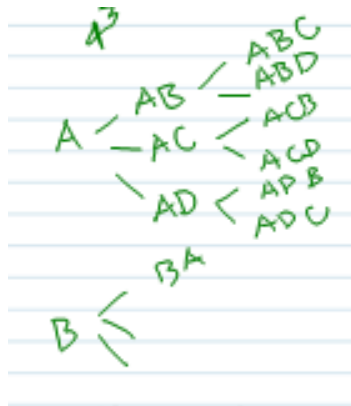

Figure 25. Kate's tree diagram for Task 13: Committee 2

Notice that Kate's tree diagram (Figure 25) for Task 13 differs from the tree diagrams that were presented with in Annette and Toni. Indeed, Kate created an incomplete tree diagram, much as Toni did in Figure 24. However, Kate's tree diagram

does not use slots to represent the positions which have not yet been filled as both Annette's and Toni's did. In addition, even though Toni's tree diagram was incomplete, she did structure the tree diagram without filling out each vertex of the tree. In contrast, Kate's tree diagram does not even include the roots of the four trees they would create in a full tree diagram. Still however, Kate was able to represent her Standard Odometer thinking using a tree diagram.

6.3.2.3.2. Boris' use of tree diagrams

Following the introduction of tree diagrams in Tasks 11 through 13, Kate and Boris were asked to complete Task 14: Letters abcdef. The statement of Task 14(vi) is below.

- Situation: Suppose we have the letters a, b, c, d, e, f and we are forming three-letter strings of letters (“words”) from these letters.
- Question: How many 3-letters “words” can be formed from these letters if repetition of letters is allowed and the letter “ d ” must be used?

While attempting to complete Task 14(vi), the students both over counted and found the answer to be $3 \times 6 \times 6 = 108$ at first. The instructor provided a Devil's Advocate that determined the solution to be $6^3 - 5^3 = 91$. The students realized that both solutions could not be correct but they both had trouble identifying which solution was correct and which involved a flaw in reasoning. In order to confirm whether the alternative solution provided was correct, Boris chose to represent the solution set visually. Boris drew the tree diagram in Figure 26, but Kate helped him determine the final solution of $11 \times 5 + 36$.

To create the tree diagram in Figure 26, Boris first wrote “*a*” and drew a couple branches off of it to represent “the tree diagram coming off of it.” He then wrote “*b*” with two branches off of it to represent “its tree diagram,” before continuing with the roots of the other trees. He then completed the next level for the tree with root *a*. From that level, it is clear that each of the roots of the other trees corresponded to the first letter in a “word” in the solution set. Thus, Boris’ reasoning was indicative of Standard Odometer. He first considered all of the options for the first slot and, for each of those, determined the number of options for the other slots. This is analogous to determining the number of leaves on a tree with a specific root.

It is interesting to note that Boris did not need to complete his tree diagram in order to determine the number of leaves on each tree. If he had completed it, there would be one leaf off of each of the vertices ‘*a a* _’, ‘*a b* _’, ‘*a c* _’, ‘*a e* _’, and ‘*a f* _’. There would be six leaves off of the vertex ‘*a d* _’. Altogether, there are 11 leaves off of the tree with root ‘*a*’. Since there are structural similarities between the tree with root ‘*a*’ and those with roots ‘*b*’, ‘*c*’, ‘*e*’, and ‘*f*’, Boris realized that those trees would also have 11 leaves and represented this fact using 11×5 in his final expression. The tree with root ‘*d*’ has a different structure than the other trees, yet Boris did not complete that tree. Instead, he *anticipated* that there would be 36 leaves on that tree, and added this number into his final expression.

Boris’ tree-diagram differs from the ones supposedly written by Annette (Figure 23) and Toni (Figure 24) in the earlier tasks. Indeed, the leaves in Figure 23 and Figure 24 each represent an element of the solution set and all of the leaves are drawn even though the elements are not all listed in Figure 24. In contrast, in Boris’ tree diagram in

Figure 26, all of the leaves are missing, many of the trees have only a root, and the use of slots to indicate where other items would be placed is inconsistent. However, the idea of using a tree diagram to visually represent Standard Odometer thinking was adopted by Boris.

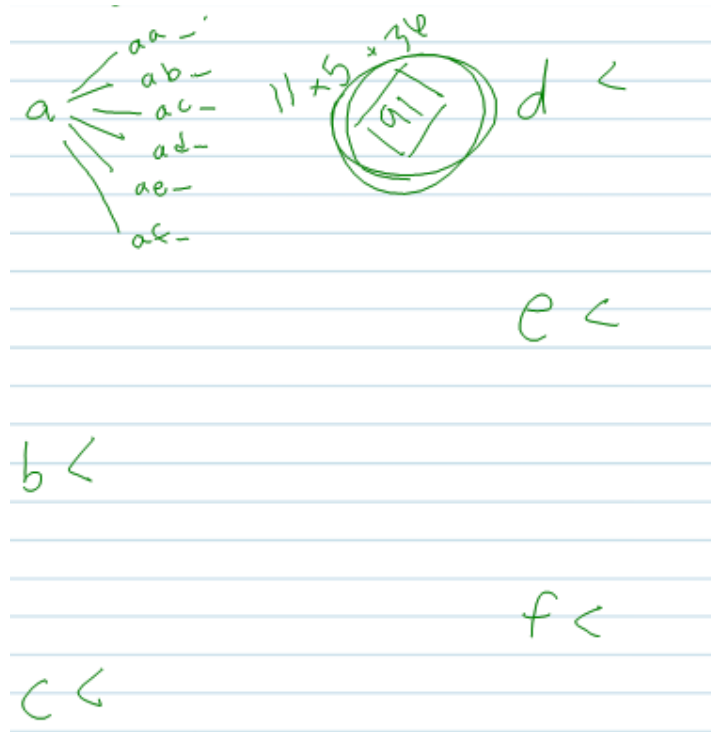

Figure 26. Boris' tree diagram for Task 14(vi): Letters abcdef

7. PROBLEM POSING WAYS OF THINKING

For many counting problems, it can be beneficial for students to construct and answer related combinatorics problems by modifying one of the criteria involved in the problem. For example, a permutation with repeated items problem could be solved by first considering a related problem involving permuting distinct items. This idea of exploiting a related problem is present in the problem solving literature. In fact, Polya (1957) includes it as one of his problem solving strategies. Silver (1979, 1981) investigated student perceptions of problem relatedness in algebra and students' use of related problems with similar mathematical structure in solving novel problems. His results showed that even when students were aware that they should remember related problems, they sometimes struggled to implement this strategy. Further, English (1999) found that students in combinatorics had difficulty identifying the structural similarities between arrangement problems with two slots and those with three slots. The students in her study were asked to pose new problems after they had seen the two-dimensional arrangement problems, but most were unable to pose solvable problems. Thus, it appears as if much can be learned from investigating students' use of problem posing in solving combinatorics problems, which is the focus of this chapter.

This chapter discusses the ways of thinking belonging to the Problem Posing category of the final framework of ways of thinking which emerged from the data analysis of this study. First, it presents definitions and examples of the three ways of thinking included in the framework: Deletion, Equivalence Classes, and Ratio. Next, it provides a model for the evolution of an epistemic student's Problem Posing ways of thinking. In this chapter, it is conjectured that the ways of thinking in this category evolve

from Weak Problem Posing to Deletion to Equivalence Classes to Ratio thinking. The evolution was analyzed using the constructs of perturbation and accommodation from Piaget’s Theory of Knowledge Development (Gruber & Voneche, 1977; Piaget, 1980, 1985). Finally, this chapter discusses the visualizations for Problem Posing thinking which were either presented through the instructional sequence or which emerged spontaneously as a student made connections between ways of thinking.

7.1. Problem Posing Ways of Thinking from the Framework

Table 12. Problem Posing ways of thinking

Category	Way of Thinking	Characterization
Problem Posing	Deletion	First, consider a given problem. Second, pose a related problem whose solution set contains a subset which has a bijective correspondence with the solution set of the original problem. Third, find an additive relationship between the solution sets. Fourth, find the cardinality of the new solution set. Next, determine the size of the complement of the subset of the new solution set which corresponds to the original solution set. Finally, use the additive relationship to quantify the size of the original solution set
	Equivalence Classes	First, consider a given problem. Second, pose a related problem with a solution set which can be partitioned into blocks of the same size – each one of which is in bijective correspondence with an element of the original solution set. Third, find a multiplicative relationship between the solution sets. Next, quantify the size of the new solution set and of each block. Finally, use the multiplicative relationship to quantify the size of the original solution set.
	Ratio	First, consider a given problem. Next, pose a related problem with a solution set which can be partitioned into blocks of the same size – each one of which has the same number of “wanted” elements which are in bijective correspondence with elements of the original solution set. Third, quantify the size of the new solution set. Fourth, find the ratio of “wanted” elements to total elements in each block. Finally, use this ratio to determine the size of the original solution set.

In this study, three ways of thinking in which students engage as they spontaneously posed new, related combinatorics questions were identified as robust ways of thinking and together they comprise the Problem Posing category of the final framework. They are summarized in Table 12. The subsections below provide operational characterizations of Deletion, Equivalence Classes and Ratio, respectively, along with examples of students engaging in each. In addition, the additive relationship in *Deletion* and multiplicative relationship in *Equivalence Classes* and *Ratio* are discussed.

7.1.1. Deletion

One productive way students might use a newly constructed solution set is present when students determine an additive relationship between the solution set to a new problem they construct and the original solution set. This way of thinking will be called *Deletion* thinking in this study. Consider Task 16(iii): Sororities:

- Situation: A university decides that sorority names can be three-letters chosen from the following Greek letters: $\Gamma, \Delta, \Theta, \Lambda, \Pi, \Phi, \Psi, \Omega$
- Question: How many sorority names can be formed from these letters if repetition of letters is allowed and the letter “ Θ ” must be used?

Kate found the answer to this task to be $8^3 - 7^3$ during the second individual interview of Phase 1. Her explanation is in Excerpt 16.

Excerpt 16. Task 16(iii): Sororities from P1_II2_K

Kate: I am just going to do the total number of options minus the ones that don't use Θ
 [...] There are $7 \times 7 \times 7$ groups of 3-letter “words” [...] that don't have Θ in them

and we are subtracting from the total... assuming that the ones that do have Θ will be left.

In Excerpt 16, Kate appears to have posed a new problem which consists of determining the total number of 3-letter “words” which could be formed from those eight distinct Greek letters. Her solution to this new problem was 8^3 . She realized that if she subtracted the number of “words” which do not include Θ (which was 7^3) from that total, she would be left with the number of “words” which do have Θ . Her remarks point to a way of thinking known as *Deletion* thinking.

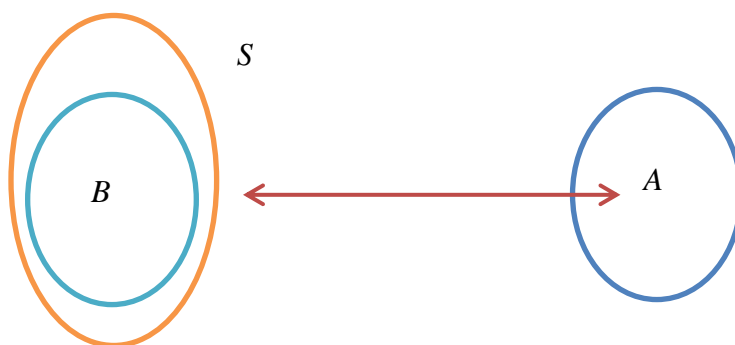

Figure 27. Deletion

Deletion thinking entails the following mental acts: First, consider a given problem with solution set A (see Figure 27). Second, pose a related problem whose solution set, S , contains a subset, B , which has a bijective correspondence with the solution set of the original problem. Third, find an additive relationship between the solution sets, namely that $B = S \setminus (S \setminus B)$. Fourth, find $|S|$, the cardinality of the new solution set. Next, determine $|S \setminus B|$, the size of the complement of the subset of the new solution set which corresponds to the original solution set. Finally, use the additive relationship to quantify the size of the original solution set (i.e. use the idea that $|A| = |B| -$

$|S| - |S \setminus B|$). Thus, a typical indication of Deletion thinking would be the use of the subtraction operation. In essence, Deletion thinking involves “deleting” the elements of the S that are not in B .

In Excerpt 16, set A is the solution set of the original problem of determining the number of words which include Θ . It appears as if Kate constructed set S as the solution set to the problem of determining the total number of 3-letter “words,” and defined set B as set A . Therefore $S \setminus B$ is the set of “words” which do not include Θ . It is worthwhile to note that although $A = B$ in Kate’s solution, Deletion thinking only requires that A and B be in one-to-one correspondence, not that they are equal.

Kate, Boris, Al, and most students in the pilot studies engaged in Deletion thinking for numerous tasks. Thus, Deletion satisfies the applicability criterion of robust ways of thinking. In addition, the students were about to reason about the relationships between elements of the two solution sets as they engaged in Deletion. Therefore, Deletion also satisfies the strong cognitive root criterion and is a robust way of thinking.

7.1.2. Equivalence Classes

Another way of thinking which involves posing new problems is rooted in multiplicative instead of additive reasoning. When engaging in this way of thinking, students partitioned a new solution set into blocks of the same size, say the size is b , each one of which corresponds to an element of the original solution set. Since each block was in one-to-one correspondence with an element of the original solution set, the new solution set was b times larger than the original solution set. Thus, in order to determine the size of the original solution set, students divided the cardinality of the new solution

set by the size of a block. This way of thinking will be called *Equivalence Classes*.

Consider Task 26: Arizona, whose statement is below.

- Situation: Remember that Arizona has 7-character license plates. In an attempt to foster state pride, the DOT agreed to provide citizens who use the letters in the word “ARIZONA” arranged in any order with a special license plate with an image of the a Saguaro Cactus and the Cactus Wren as the background.
- Question: How many of these special license plates must the state create?

After reading the task, the students in Phase 1 were given a few seconds to gather their thoughts. Kate shared her thoughts first and her response is below.

Excerpt 17. Task 26: Arizona from P1_PS4

Kate: I disregarded the facts that there's a repeated letter and I just said “how many ways can [...] you arrange these seven letters?” and that's going to be $7!$. But, um, you're going to have to take some of those out. [...] I think for every [...] one possible order of the letters, you're going to have another [...] that's the same because there's only one letter that is repeated. So like, if we had like just a random RZIANOA there's going to be two ways. By this, there's $7!$, which count that [RZIANOA] twice. So I think you just divide $7!$ by 2 to take those out.

In the above excerpt, Kate’s first inclination was to pose a new problem where there was no “repeated letter” involving permuting “these seven letters.” Her newly posed problem appeared to be permuting seven distinct letters. This conjecture is supported by the fact that she found the answer to such a problem to be $7!$. She

recognized that the repeated A's would actually mean that she had counted twice as many permutations as she had wanted and compensated by dividing $7!$ by 2.

In a similar manner to the students who engaged in Deletion thinking, Kate constructed a new problem, and found a relationship between the elements of the solution set to the new problem and the one whose cardinality she wanted. However, unlike in Deletion thinking, the relationship she found did not involve subtracting the superfluous elements, but rather grouping equivalent elements together. This is indicative of a way of thinking known as *Equivalence Classes*.

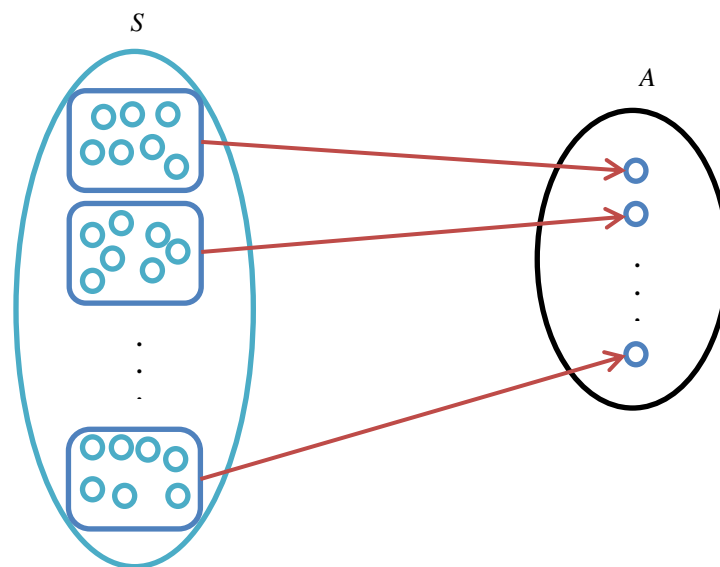

Figure 28. Equivalence Classes

As a way of thinking, Equivalence Classes entails the following mental acts: First, consider a given problem with solution set A (see Figure 28). Second, pose a related problem with a solution set, S , which can be partitioned into blocks of the same size – each one of which is in bijective correspondence with an element of the original solution set. Third, find a multiplicative relationship between the solution sets. Next, quantify the

size of the new solution set, $|S|$, and of each block, b . Finally, use the multiplicative relationship to quantify the size of the original solution set (i.e. use the fact that $b \cdot |A| = |S|$). In order to find $|A|$, a student would likely divide $|S|$ by b . Thus, a typical indication of Equivalence Classes is the use of the division operation.

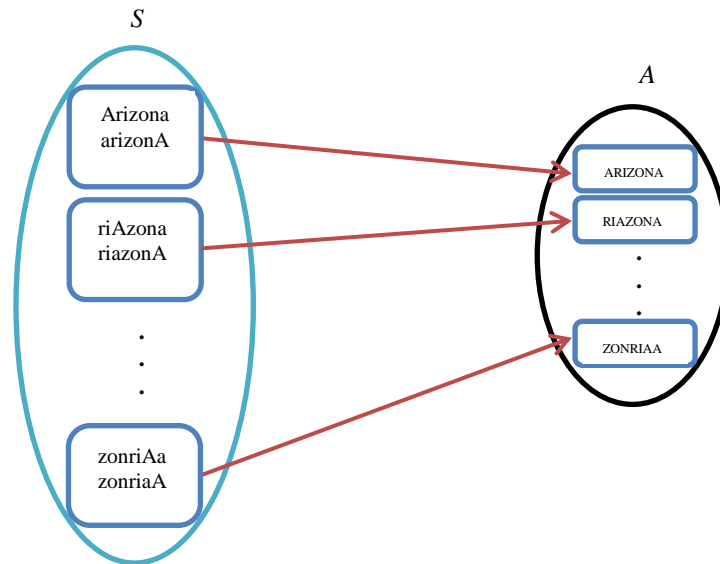

Figure 29. A model of Kate's Equivalence Classes for Task 26: Arizona

In Kate's response to the Task 26: Arizona in Excerpt 17, it seems as if set A is the number of permutations of the letters in "ARIZONA." Set S is the solution set to Kate's new problem of permuting seven distinct letters. Kate's Equivalence Classes are modeled in Figure 29. For clarity, in this figure, her newly posed problem is represented as permuting the letters in "Arizona" because the "A" and the "a" could be thought of as distinct items. Then a permutation of "Arizona" would correspond to a permutation of "ARIZONA" if the latter could be created from the former by placing it in capital letters.

Following the introduction of Equivalence Classes through a Devil's Advocate for Task 18: Table, all of the students in this study engaged in Equivalence Classes for

numerous tasks. Thus, Equivalence Classes satisfies the applicability criterion for robust ways of thinking. In addition, Equivalence Classes provided students with a way to reason about the relationship between elements of the solution sets. Therefore, Equivalence Classes also satisfies the strong cognitive root criterion and is a robust way of thinking.

7.1.3. Ratio

A third way of thinking belonging to the Problem Posing category emerged from the data analysis of the second phase of the study. Under this way of thinking, the student posed a new problem whose solution set could be partitioned into blocks of the same size, each of which contains the same number of elements that correspond to elements of the original solution set. By finding the ratio of these elements to the total number of elements in the block, the student has found a multiplicative relationship between the two solution sets. This way of thinking will be called *Ratio*. Consider Task 2: Dice, whose statement is below.

- Situation: Two dice are rolled, one white and one red.
- Question: How many outcomes are there that are not doubles?

Al revisited this task in the eighth session of Phase 2. His reasoning regarding this task is shown in Excerpt 18.

Excerpt 18. Revisit Task 2: Dice from P2_S8

Al: You could say six ways to do the first, six ways to do the second (writes “ 6×6 ”) and for every six rolls [...] I guess you could multiply it [the total] by five over

six (writes $\frac{5}{6}$ after the 6×6). I guess it's trying to figure out [...] what fractions of the answers you have are repetitions, and you are trying to find that fraction and you could multiply it by that.

It appears as if Al posed a new problem consisting of determining the total number of rolls possible. This is consistent with his expression of 6×6 . Al was not familiar with quantifiers, so when he said “for every six rolls,” it is unlikely that he was actually referring to every subset of size six of the solution set of the new problem. Instead, it appears he had partitioned the new solution set into groups of six (perhaps based on the number on one of the die), and for each of those groups of six, he recognized that there were five rolls which were actually wanted, and one (the double) which was not. It appears as if multiplied the size of the new solution set by this ratio. In his concluding sentence above, he said that he was trying to find the fraction of the “answer” that were “repetitions.” Al seems to have used the term “answer” to refer to the size of the solution set of the new problem. He had a tendency to refer to the elements of the new solution set which did not correspond to elements of the original solution set as “repetitions.” As a result, it is possible that he meant that he would find the fraction of the new solution set which were *not* repetitions. This is consistent with his approach to the dice problem above. His way of thinking is indicative of *Ratio* thinking.

Ratio thinking entails the following mental acts: First, consider a given problem with solution set A . Next, pose a related problem with a solution set, S , which can be partitioned into blocks of the same size – each one of which has the same number of “wanted” elements which are in bijective correspondence with elements of the original

solution set. Third, quantify the size of the new solution set. Fourth, find the ratio of “wanted” elements to total elements in each block. Finally, use this ratio to determine the size of the original solution set.

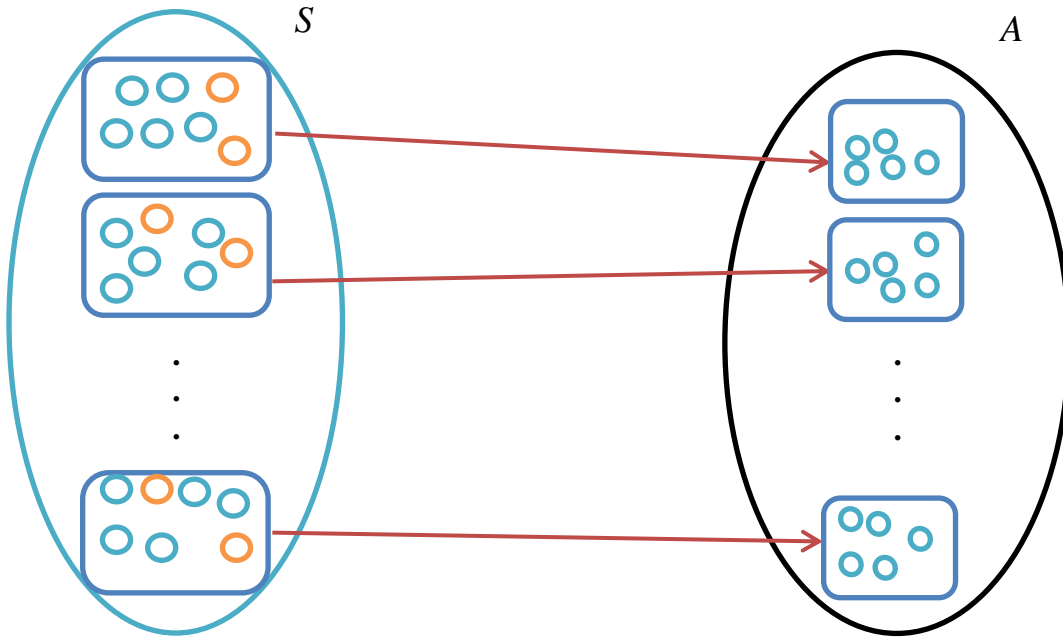

Figure 30. Ratio thinking

In Figure 30, the blue elements are the ones which are wanted and the orange are the ones which are not – each block has size 7 and there are 5 wanted elements in each block. Notice that the ratio of the “wanted” elements to the total number of elements in each block is the same as the ratio of “wanted” elements in the entire new solution set to the total number of elements in the new solution set. Thus, by multiplying the size of the new solution set by this ratio, the size of the original solution set can be found. In Figure 30, the solution set of the original problem would be $5/7$ of the size of the new solution set. In fact, a typical indication of Ratio thinking is the use of multiplication by a proper fraction.

In AI's response to Task 2: Dice in Excerpt 18, set A consisted of the outcomes which were not doubles, and set S consisted of the total number of outcomes. His solution is modeled in Figure 31. Each outcome in his solution is represented as an ordered pair with one red coordinate and a second black coordinate in Figure 31. The element $(1,5)$ corresponds to the outcome for which the red die was 1 and the white die was 5. Though AI did not specify how he was grouping the elements of the new solution set, saying only that there were six total in each group of which five were good, the blocks are represented in the figure as groups based on the number on the red die. The blocks of set S are shown with the blue rounded rectangles, and the elements of set S which were "unwanted" are represented with orange parentheses.

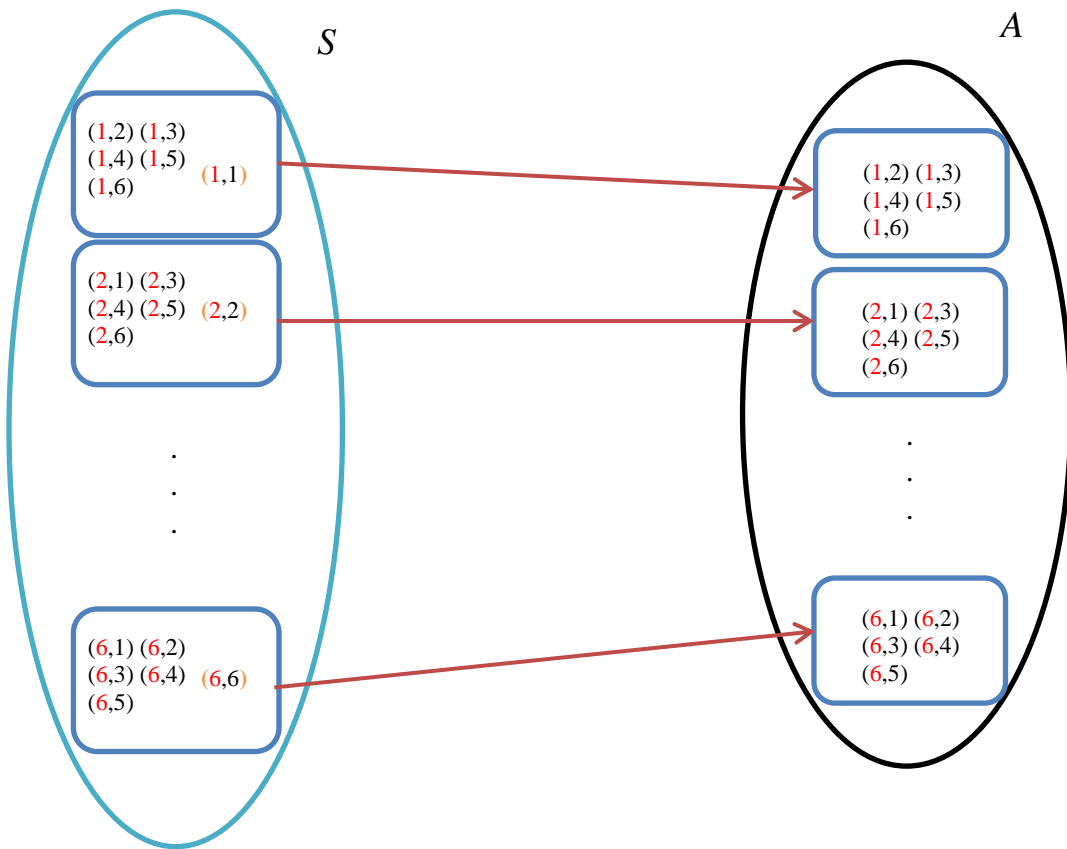

Figure 31. A model of AI's Ratio thinking for Task 2: Dice

Al was the only student who engaged in Ratio thinking in this study. Because Al engaged in this way of thinking for multiple tasks, and it seemed likely that other students exposed to this way of thinking could reason in this manner for other tasks, Ratio was said to satisfy the applicability criterion for a robust way of thinking. In addition, Ratio provided Al with a way to reason about the relationships between elements of the solution set – namely that they could be grouped based on their corresponding blocks in the new solution set. Thus, Ratio satisfies the strong cognitive root criterion and is considered a robust way of thinking.

Notice that the representations for Equivalence Classes and Ratio are very similar. In fact, Equivalence Classes can be thought of as a special case of Ratio thinking. Equivalence Classes was described as partitioning a new solution set into blocks of the same size, each one of which corresponds to an element of the original solution set. Therefore, if the size of a block is b and the size of the new solution set is s , then the size of the original solution set is $\frac{s}{b}$. Suppose instead that one element in each block was chosen to be representative of the entire block. Then we could say that the block contained one “wanted” element. The ratio of the “wanted” elements in each block to the size of the block would then be $1:b$. Therefore, by engaging in Ratio thinking, a student could recognize that the size of the original solution set is $\frac{1}{b}$ times as large as the size of the new solution set. Certainly multiplying by $\frac{1}{b}$ is equivalent to dividing by b . Though Ratio thinking can be applied when Equivalence Classes is appropriate, Ratio thinking is

appropriate for tasks for which Equivalence Classes is not. Therefore, it can be viewed as a generalization of Equivalence Classes.

7.2. The Evolution of Problem Posing Ways of Thinking

For the students in this study, posing new problems was a very natural approach to the questions. However, they were not always able to determine a relationship between the elements of the new solution set and that of the original solution set which could be used to find the size of the original solution set. Indeed, Weak Problem Posing, discussed in Section 4.5.3.1.3, is a Problem Posing way of thinking which was not considered robust because of a lack of a strong cognitive root. When students engaged in this way of thinking, they often ran into difficulties in solving the problem they were working with. In addition, students sometimes found an additive relationship between the elements of the solution sets when a multiplicative one would have been more fruitful in the sense that it would yield a solution to the task. A discussion of the limitations of the ways of thinking in the Problem Posing category, the perturbation a student could experience when confronted with these limitations, and the resulting accommodation to develop new Problem Posing ways of thinking is presented in this section.

In this Section, it is conjectured that students' ways of thinking in the Problem Posing category could evolve from Weak Problem Posing to Deletion to Equivalence Classes and finally to Ratio. Here, the term "evolve" is used to describe the order in which these ways of thinking emerge in the students, but the emergence of a later way of thinking does not mean the disappearance of a previous one. For example, according to the conjecture, Deletion thinking is a pre-cursor to Equivalence Classes, but the reader should not assume that Equivalence Classes replaces Deletion thinking.

This section first examines the sessions in which Kate, Boris, and Al engaged in Weak Problem Posing, Deletion, Equivalence Classes, and Ratio. In this way, the conjecture of the evolution above is supported from the data. The remainder of this section is devoted to a detailed model for the evolution of an epistemic student's ways of thinking as she progresses through the tasks used in this study. This model suggested in this section is also supported by examples from the data, but as indicated by the meaning of "epistemic student" it does not exactly model the evolution of any particular student's ways of thinking.

Table 13 summarizes the Problem Posing ways of thinking observed from various sessions for each of the students involved in this study. The columns in Table 13 correspond to the ways of thinking in the Problem Posing category. Each row indicates in which sessions that student engaged in that way of thinking and uses the naming convention described in Table 2. For example, the first row illustrates that Kate engaged in Weak Problem Posing in the initial interview, as well as Deletion thinking. In the second interview, and all following sessions, she engaged in Equivalence Classes thinking. However, for Kate, Deletion thinking was still present during some of those same sessions. Boris, on the other hand, did not appear to engage in Weak Problem Posing. He did engage in Deletion thinking in most of the sessions, and once he had developed Equivalence Classes in the second individual interview, he also engaged in Equivalence Classes for the remaining sessions as well. Like Boris, Al did not appear to engage in Weak Problem Posing. He engaged in Deletion thinking most of the sessions, developed Equivalence Classes during the fifth session, and continued to engage in Equivalence Classes for tasks in the remaining sessions. On the other hand, unlike Kate

and Boris, he developed Ratio thinking during the eighth session and engaged in it during the next session as well.

For all of the students in this study, Equivalence Classes emerged after Deletion had. For Kate, Weak Problem Posing emerged before Deletion did. In addition, Al’s way of thinking evolved to Ratio thinking after Equivalence Classes. Thus, the data from this study support the conjecture that Problem Posing thinking could evolve from Weak Problem Posing to Deletion to Equivalence Classes and finally to Ratio.

Table 13. Problem Posing ways of thinking observed from specific sessions

	Weak	Deletion	Equivalence Classes	Ratio
Kate	II1	II1, PS1, PS2, II2, II3	II2, PS3, PS4, PS5, II3	
Boris		II1, PS1, PS2, II2, II3	II2, PS3, PS4, PS5, II3	
Al		II1, PS1, S3, S4, S5, S8, S9	S5, S6, S7, S8, S9	S8, S9

The remainder of this section presents a model for the evolution of the ways of thinking in the Problem Posing category for an epistemic student who will be named “Emily” for simplicity. The viability of this model is supported with examples from Kate, Boris, and Al.

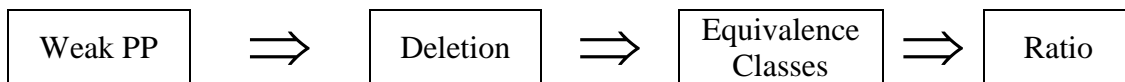

Figure 32. Model of the evolution of Emily’s Problem Posing ways of thinking

The evolution of Emily’s Problem Posing ways of thinking is modeled in Figure 32 and is described in detail below. A preliminary version of this model served as a conceptual analysis of students’ Problem Posing ways of thinking, yet it was refined

through the results of the pilot studies. This preliminary model influenced the ordering of the tasks used in this study and it is referenced in the description of the tasks in Appendix A. However, some parts of this model were not present in the preliminary model and instead emerged from the analysis of the data from this study. For example, Ratio thinking had not been identified before this study and was therefore not part of the preliminary model. In addition, the overall ideas presented below were fleshed out through this study.

It is assumed that Emily would have a similar background to the students who participated in this study and in the pilot studies. In other words, she would be an undergraduate enrolled in a calculus course. She would not have had any formal experience with combinatorics, though she may have solved a few counting problems on exams such as the Scholastic Achievement Test (the SAT). Further, it is assumed that she would progress through the tasks as they are described in Appendix A.

7.2.1. Weak Problem Posing

Without any formal instruction in combinatorics, an epistemic student might engage in Weak Problem Posing. Consider Task 1: Mississippi I, whose statement is below.

- Situation: Imagine that the state of Mississippi is adopting new, 11-character license plates. For fun, the state agreed to provide citizens who use the letters in the word “MISSISSIPPI” arranged in any order with a special license plate with an image of the mockingbird (the Mississippi state bird) as the background.

- Question: How many of these special license plates with the mockingbird must the state be prepared to create?

For this problem, Emily might recognize that the repeated letters add a level of complexity to this problem and choose to begin with smaller problems such as permuting the letters in MISP and MISS. For the latter problem, she could engage in Weak Problem Posing by first constructing a new problem where the letters were distinct, generating elements of the new solution set by trial-and-error, and identifying elements of the new solution set with elements of the original solution set. She could physically list out the corresponding elements of the original solution set and, when she saw an element that had already been listed, cross it out. In this study, Kate engaged in Weak Problem Posing for permuting the letters in MISS.

7.2.1.1. Example from the data (Kate)

When presented with Task 1, Kate claimed that she did not know how to deal with the length of MISSISSIPPI and would prefer to make it simpler. The researcher encouraged her to do so and she first chose to permute the letters in MISP. She did this by holding the M constant and varying the other items in the other slots by engaging in Disney thinking (this is discussed in more detail in the next chapter). At first, Kate only found four permutations of MISP that began with M, though she did quickly correct her solution. She recognized that there would be four times as many permutations in total than the number that began with M. The researcher pointed out that MISSISSIPPI did not involve all distinct letters, and Kate stated she would make it simpler and work with MISS. For the case of MISS Kate said, “I would just start rearranging them and see how

many I could get.” The researcher asked her how she would know she had found everything. Her response is in the following excerpt.

Excerpt 19. Variation of Task 1: Mississippi 1 from P1_III_K

Kate: I wouldn't really know for sure. I would do the same thing here [as MISP] as I would use one letter first and then do all of the ones with that letter first. And then I'd get some repeating because there are two S's [in MISS] and I'd cross those out and then I'd do it with another letter first.

It appears as if Kate had posed a new question, that of permuting four distinct items by treating the S's in MISS as if they are distinct. This is supported by the fact that she said she would be repeating elements of the solution set. Her approach would be to simply cross out any elements she did not want before continuing by beginning with a different letter. Ultimately, Kate was able to pose a new problem involving permuting distinct items, but she did not quantify the size of the new solution set. As a result, she did not find a relationship between the elements of the new and original solution set. This is indicative of Weak Problem Posing. Notice that since Kate did not find a relationship between the elements of the new and original solution sets, her way of thinking required her to generate all elements of the new solution set and physically list the corresponding elements of the original solution set.

One could assume that Kate would determine the answer to the question of how many ways there were to permute the letters in MISS by checking the length of her list. This approach would likely yield the correct answer, though it is possible that Kate would miss a permutation or not notice that an element was listed twice. In this particular case,

it appeared as if Kate was still struggling to determine a systematic way to vary the other items in the other slots for MISIP, so the repeated item might have led to even more confusion.

7.2.1.2. Comparison to Emily

In a similar manner to Kate, the epistemic student Emily might engage in Weak Problem Posing to permute the letters in MISS. After doing so, she might attempt to engage in Weak Problem Posing to permute the letters in MISSISSIPPI. However, she might have more difficulty finding a numerical answer to the question because of the number of repeating items and slots involved in MISSISSIPPI. Indeed, since Weak Problem Posing requires the student to generate all elements of the new solution set and physically list the corresponding elements of the original solution set, Emily might struggle with maintaining this list for permuting the letters in MISSISSIPPI.

For Task 1, Emily might construct a new problem involving permuting the letters in $MI_1S_1S_2I_2S_3S_4I_3P_1P_2I_4$, and then state that she could “flatten” this arrangement to remove the subscripts. She would then check a list of permutations of MISSISSIPPI that she was maintaining. If the new permutation were already listed, she would generate a another permutation and repeat. If it were not already listed, she would add this permutation to the list and then repeat. This approach is similar to Frank’s Weak Problem Posing approach for the WELLESLEY problem, as described in Section 4.5.3.1.3 above. Like Frank, Emily might realize that although the length of the list would ultimately give the answer to the question, she would have difficulty knowing for sure that her list was complete. Indeed, she may have trouble determining if she had constructed every possible permutation of $MI_1S_1S_2I_2S_3S_4I_3P_1P_2I_4$ or if she accidentally listed a permutation of

MISSISSIPPI twice in her list. Thus, Emily might engage in Weak Problem Posing for Task 1 and be able to pose a new problem, but she might struggle to use the new solution set in a productive manner.

7.2.2. Weak Problem Posing → Deletion

As indicated above, a limitation of Weak Problem Posing is that it requires a student to generate all possible elements of the new solution set and to list all corresponding elements of the original solution set without repetition of elements. Emily may experience perturbation as she realizes this limitation while attempting to engage in Weak Problem Posing for tasks involving large solution sets. In order to resolve such perturbation, she might search for a more systematic way of using the elements of the new solution set. Ultimately, she may make an accommodation and find an additive relationship between the elements of the new solution set and the original solution set, However, she may not jump immediately to quantifying the size of the new solution set and its unwanted elements when she first begins solving counting problems. In other words, she might not use the additive relationship in the way associated with Deletion. Instead, she might deal with the unwanted elements in the middle of her consideration of elements of the new solution set. However, she would be able to anticipate the size of the original solution set by using the relationship.

7.2.2.1. Transition from Weak Problem Posing

Emily would search for relationships between elements of the new and original solution sets in order to resolve the perturbation she experiences when she realizes the limitations of Weak Problem Posing. In her search, she may engage in a way of thinking which will be called *Deletion in the Middle*.

It is possible that Emily would engage in Deletion in the Middle as early as the next task, Task 2: Dice whose statement is below.

- Situation: Two dice are rolled, one white and one red.
- Question: How many outcomes are there that are not doubles?

For this task, Emily might construct a new problem: “How many total outcomes are there?” She might not find the size of this new solution set, but she could consider all of its elements, immediately discarding the elements she did not want. Kate engaged in such a way of thinking during the first interview.

7.2.2.1.1. Example from the data (Kate)

Kate employed the Deletion in the Middle way of thinking for Task 5: Security Codes:

- Situation: A security code for a computer involves two letters. It is case insensitive, but the two letters must be different from each other.
- Question: How many possible security codes are there for this computer?

This task was designed to be similar to Task 2: Dice, but was written so that the numbers involved were larger and students might feel the need to determine a systematic manner of determining the size of the solution set. Kate found the answer to be $26 \times (26 - 1)$, reasoning as follows:

Excerpt 20. Task 5: Security Codes from P1_III1_K

Kate: Um...so there's twenty six letters. (writes "26") [The number of] options for the first letter is twenty six. [5 second pause] [The number of] options for the second

letter is twenty six minus one (writes " $\times 26 - 1$ ") because whatever the first [...] letter is, [...] (encloses "26-1" in parentheses) you can't have that letter [...] be the second letter so you have to subtract that letter from the total twenty six. So, yeah, twenty six times twenty five (writes 26×25).

For this task, Kate first determined that there were 26 possibilities for the first letter in the code. For each of those, she determined the number of possibilities for the second letter, keeping in mind that she had already used one letter. This means that she first considered letters that would create a code that did not satisfy the requirements from the question, thereby indicating she had posed a new problem. Since she was eliminating the unwanted element in the middle of her counting process, this way of thinking is called "Deletion in the Middle."

7.2.2.1.2. Comparison to Emily

Though Kate engaged in Deletion in the Middle thinking towards the end of the first individual interview and actually engaged in Deletion for the Dice problem (Task 2), it is quite possible for the epistemic student, Emily, to engage in Deletion in the Middle before fully developing true Deletion thinking. Indeed, for Task 2, Emily could pose the problem "How many total outcomes are there?" She could argue that if there is a 1 on the red die, there could be a 1, 2, 3, 4, 5, or 6 on the white die. She could immediately recognize that a 1 on both dice is not something she wants, so she could eliminate this outcome. She might recognize that there would be $6 - 1$ outcomes she would want for each of the other options for the red die and find the solution $6 \times (6 - 1)$. This would be indicative of Deletion in the Middle thinking.

Notice that in the solution above, Emily would be considering outcomes of the dice she does not actually want. However, since she is not quantifying the size of the solution set of the new problem nor quantifying the size of the complement of the subset that corresponds to the original solution set, she would not be engaging in true Deletion thinking. Also, Deletion in the Middle differs from Weak Problem Posing because Emily found a way to quantify the size of the original solution set without physically listing all elements of the original solution set. Indeed, it appears as if Deletion in the Middle is more systematic than Weak Problem Posing. Deletion in the Middle could be a stepping stone as Emily's Problem Posing ways of thinking evolve from Weak Problem Posing to Deletion.

7.2.2.2. Transitioning to true Deletion thinking

Emily would not be likely to engage in Deletion in the Middle for long. Indeed, Deletion in the Middle requires that she consider an element of the new solution set and determine whether a corresponding element is in the original solution set before considering another element of the new solution set. In other words, Deletion in the Middle requires constant coordination between elements of the new and original solution sets. Emily may experience a perturbation when she realizes that she is not quantifying the size of the new solution set in this process. She might also realize that it could be less cognitively taxing to consider all of the elements of the new solution set before determining the relationship between the elements of two solution sets. In order to resolve such perturbation, she might continue to search for a systematic way of using additive relationship between the solution sets that she had found. Thus, she may quantify the size of the new solution set and subtract the number of its "unwanted" elements,

thereby engaging in Deletion. All three of the students in this study engaged in Deletion thinking as early as Task 2. Therefore, there is no data to support viability of the claim that Problem Posing could evolve from Deletion in the Middle to true Deletion thinking

If Emily had not yet developed Deletion thinking by Task 5: Security Codes, she would be exposed to it through Devil’s Advocate to David’s alternative argument driven by this way of thinking, shown below. This task asks students to determine the number of case-insensitive two-letter security codes.

David’s alternative argument to Task 5 (Security Codes): There are 26 two-letter strings which start with A: AA, AB, ..., AY, AZ. There are also 26 two-letter strings which start with B: BA, BB, ..., BY, BZ. Similarly, there are 26 two-letter strings which start with each of C through Z. Altogether, there are 26×26 total two-letter strings. Now, we have 26 two-letter strings which are not acceptable as security codes (AA, BB, CC, ..., ZZ). This idea is summarized in the table below. There are 26 columns, and 26 rows, but 26 two-letter strings are crossed out. Therefore, we have $(26 \times 26) - 26$ total security codes.

AA	BA	CA	DA	. . .	YA	ZA
AB	BB	CB	DB		YB	ZB
AC	BC	CC	DC		YC	ZC
AD	BD	CD	DD		YD	ZD
.
.
.
AY	BY	CY	DY		YY	ZY
AZ	BZ	CZ	DZ	. . .	YZ	ZZ

If Emily has not yet developed Deletion thinking, David's argument may cause some perturbation. However, since she had posed new problems before, by engaging in Weak Problem Posing or Deletion in the Middle, she could quickly resolve this perturbation and explain the solution in her own words. It is probable that Emily would have developed Deletion thinking before this point, as discussed above for Task 4. David's argument would then serve as an instructional provocation to highlight that Deletion could drive a solution to this task.

7.2.3. Deletion \rightarrow Equivalence Classes

Suppose that a student has Deletion as a way of thinking. The student could pose a new problem whose solution set could be partitioned into blocks of the same size. These blocks would be in a bijective correspondence with the elements of the original solution set. A single element of each block could be chosen to be representative of the block. The representative elements of the new solution set would then form a subset of the new solution set which would be in the bijective correspondence with the elements of original solution set. The student engaging in Deletion thinking could attempt to find the size of the new solution set and the number of non-representative elements in the new solution set. However, he or she might have trouble with the accomplishing this latter task. This is a limitation of Deletion thinking. A student recognizing this limitation might experience a perturbation, ultimately making an accommodation and developing Equivalence Classes. This subsection first describes this limitation of Deletion thinking in more detail, along with the perturbation Emily could experience. It then presents a Devil's Advocate driven by Equivalence Classes and the accommodation Emily might make to resolve such perturbation.

7.2.3.1. Perturbation because of limitation of Deletion thinking

By the fourth session of the study, Emily would certainly be accustomed to engaging in Deletion thinking – posing new, related problems and determining an additive relationship between the elements of the solution set to the original problem and that of the new problem. However, she might experience perturbation when presented with a task for which a multiplicative relationship might be more productive. For example, for a task involving circle permutations, she might attempt to engage in Deletion thinking by first posing a new problem of arranging people in a line. However, this could result in a state of disequilibrium if she could only find an additive relationship between the elements of the solution sets.

7.2.3.1.1. Example from the data (Boris)

Consider Task 18: Table:

- Situation: A bunch of people would like to sit around a large, round table. It doesn't matter to them which particular seat they sit in, but they do care about the people who will be sitting to either side of them.
- Question: In how many ways can n people sit around a circular table?

Certainly there are plenty of different solutions to this task. Kate engaged in a form of Broken Odometer (see Section 4.5.3.1.1 above for more information on this way of thinking), placing one person down at the table and then arranging the other people. One other approach is to pose a new problem involving arranging the people in a line.

Boris viewed the problem of arranging people in a line as equivalent to arranging people around the table, even though he had previously discussed a variety of table

arrangements and whether they were the same or different from each other. He argued that there were $n!$ ways to arrange the n people around the circular table. When the researcher reminded him of the previous discussion regarding the various table arrangements, he said that moving one person to the “last spot” would create a different “order” for the line, but not for the table. He stated that there were “ n different ways that they can sit in the same order.” He clarified that what he meant was that if there were five people, there would be five different ways for them to sit in the same order, but in different seats. Thus, it appears as if he had constructed a new problem consisting of arranging people in a line, and made a connection between that problem and the original problem. In his case, the slots in the line problem corresponded to different seats about the table. When he used the term “order,” he was referring to elements of the solution set of the original problem.

In an attempt to form a relationship between the elements of the new problem and that of the original problem, Boris stated “you would [...] subtract n times the total number of ways they can sit, [...] the total [...] [number of] orders.” The researcher implemented Stimulating Questions to help Boris realize that if $n!$ is n times the number of orders, and only one was wanted, $(n-1)$ times the number of orders would need to be subtracted. The researcher also pointed out that Boris was trying to count the number of orders. After a pause of over a minute, Boris admitted that he was not sure how to proceed from there. Boris’ long pause indicates that he experienced a perturbation. His inability to determine how to proceed supports this claim and also indicates that he had trouble resolving his perturbation.

7.2.3.1.2. Comparison to Emily

Emily, if she had attempted to engage in Deletion thinking for Task 18: Table problem, would be able to construct equivalence classes and even quantify their sizes, She would be able to pose a new problem of arranging n people in a line instead of a circle, and she would be able to determine that n elements of the solution set of the new problem corresponded to an element of the original solution set. However, Emily would likely encounter the same difficulties Boris did. Because she could only conceive of an additive relationship between elements of the two solution sets, she, like Boris, would experience a perturbation and perhaps recognize a limitation of Deletion thinking.

7.2.3.2. Equivalence Classes as accommodation of Deletion thinking

For Task 18: Table, Emily could pose a new problem consisting of arranging n people in a line and determine that n of these arrangements correspond to one arrangement about the table. However, if she could not conceive of a multiplicative relationship between the elements of the two solution sets, she would experience a perturbation. An alternative argument driven by Equivalence Classes thinking would then be presented via Devil's Advocate. There are three stages to this argument, which is attributed to Pat, a former student. These stages progress from more generality to less. The student would be told that Pat chose to use $n = 4$ and that Figure 33 was the scratch work Pat presented.

The elements in Figure 33 correspond to permutations of the letters A , B , C , and D . They are arranged so that when the permutations are thought of as circles, with the letter in the last slot next to the letter in the first slot, the rows correspond to the same table arrangement. Very little information is presented in the first stage with the intention

of allowing the researcher to see what connections students make between this representation and the problem – these connections depend on how the student was originally viewing the elements of the solution set of the original problem.

ABCD	BCDA	CDAB	DABC
ABDC	BDCA	DCAB	CABD
ACBD	CBDA	BDAC	DACB
ACDB	CDBA	DBAC	BACD
ADBC	DBCA	BCAD	CADB
ADCB	DCBA	CBAD	BADC

Figure 33. First Stage of Pat’s Argument for Equivalence Classes thinking

Emily, when presented with the Devil’s Advocate in Figure 33, would likely recognize that the rows all correspond to the same table arrangement because of how she was already envisioning the solution set of the new problem. She would also recognize that it would be possible to count the number of rows, which would give the answer to the original question. She may still not have found the multiplicative relationship though, and may have trouble generalizing. This was the case for Boris.

7.2.3.2.1. Example 1 from the data (Boris)

Boris was able to determine that there were six orders of the table represented in Figure 33. He was then presented with the second stage of Pat’s solution for the Table problem, which highlighted the fact that there were four columns. He had not yet fully made a connection between the table and the solution set of the problem of arranging n

people around a table. Indeed, when he was asked what would happen with five people, he claimed that there would be one more column and one more row. He seemed to experience some perturbation at this point because he was unsure of this solution. He paused several times in his utterance, particularly before claiming there would be one more row.

Through discussion with the researcher, Boris realized that the 24 cells in the table were the $4!$ ways to arrange four people in a line. He stated that there would be $5!$ ways to arrange five people in a line and that there would be five columns. He was able to state that there would be 24 rows because “well, five factorial is 120 [...] If there are five columns, then we have to do 120 divided by five.” He concluded that there were 24 ways to arrange five people around a table and $n!/n = (n-1)!$ ways to arrange n people around the table. It appears as if the two stages of Pat’s solution to the Table problem caused Boris some perturbation as he tried to understand, and generalize from, them. However, he was able to resolve such perturbation, and make an accommodation. Since he was able to apply the same problem solving approach to the specific problem of arranging five people around the table, and to the more general problem of arranging n people around the table, it is likely that this accommodation involved developing Equivalence Classes thinking.

7.2.3.2.2. Comparison to Emily

It is possible that Emily would follow a very similar learning trajectory to Boris’. She would probably be able to generalize to n people after being presented with either the first or second stage of Pat’s solution, perhaps with some guidance from the researcher.

However, if she had engaged in a different initial approach driven by a way of thinking in a different category from Table 7 she may have trouble even understanding the table shown in Figure 33.

7.2.3.2.3. Example 2 from the data (Kate)

Kate had engaged in Broken Odometer originally for the table problem, visually using cards to arrange people around the table. She could not initially understand why Pat had organized the table in the manner he had. She viewed the columns as being constructed around where A was being held constant, but she also eventually realized that the cells in a row corresponded to rotations of the same table, which should all be considered the same. However, even after seeing the second stage of Pat's solution which highlighted the fact that there were four columns, she believed that the four shown was simply to emphasize that there were $n = 4$ people in Pat's solution. At prompting from the researcher, she attended to the number of cells in each row and stated "that's four ways that that same order could be represented on the table, but according to the problem it's the same order." Here, Kate used the term "order" to refer to elements of the original solution set, though she was treating the positions around the table as distinct. However, she recognized that everything in a row corresponds to a single element of the solution set. The researcher asked how many times she wanted to count that order, and Kate responded "once. So if you took the entire thing, you'd divide it by four." At this point, the researcher provided the third stage of Pat's solution which simply stated " $4!/4 = \frac{4 \cdot 3 \cdot 2 \cdot 1}{4} = 3 \cdot 2 \cdot 1 = 3!$." Kate's response, however, was to say that she would not have gotten $4!$, she would have said 24. After a long pause, the researcher asked Kate how $4!$ related

to four people, but her response, shown in Excerpt 21, had to do with holding people constant around the table.

Excerpt 21. Task 18: Table from P1_II2_K

Kate: Well I think, the way I would have gotten those twenty four, is just by trying to list all of the different ways that those four people could be seated. And I would have held one letter constant, and rearranged the other letters around [...] that letter. And while doing that I would have [...] essentially multiplied by that four because I would have kept changing that letter that I was rotating around. [...] But then once I had that [...] I probably would have it in [...] the chart like this and then [...] I may or may not realize that [...] each of these rows was basically the same order, rotating around the table.

Essentially, even after seeing all three stages of Pat's solution, Kate had not constructed the problem of arranging people in a line. Instead, since her original problem solving approach had involved holding one person (represented with letters on physical cards) constant at the table, she could only conceive of creating the table using that same approach. Once the researcher mentioned the idea of unclasping a circle to form a line, Kate was able to understand Pat's argument and generalize to the case of n people.

7.2.3.2.4. Comparison to Emily

If Emily had approached the Table problem initially by engaging in Odometer thinking, she likely would have experienced significant perturbation in the same way that Kate had. Still, she would probably have been able to resolve such perturbation and generalize to the case of n people being arranged around a table.

Regardless of whether her initial approach belonged to the Odometer or Problem Posing category, Emily would experience perturbation when she encountered the Table problem and would eventually make an accommodation to develop Equivalence Classes thinking. There would be plenty of opportunities for the student to strengthen this way of thinking as she assimilated other tasks.

7.2.4. Equivalence Classes \rightarrow Ratio

Students may believe that Equivalence Classes could be used to solve all questions for which posing a new problem is productive. For example, students may believe that Deletion and Equivalence Classes are hierarchical. In a way, they are – certainly students tend to develop one before the other. Emily would be naturally able to pose new problems, and could easily find an additive relationship between the elements of the solution set of the new problem and the original problem. However, it would not be until the Table problem and the corresponding Devil’s Advocate of Pat’s argument that she would experience perturbation and make an accommodation as a result. Still, it is not true that Equivalence Classes is always appropriate where Deletion might be. Indeed, unless the size of the new solution set is a multiple of the size of the original solution, it would not be possible to partition the new solution set into blocks of the same size that are in a bijective correspondence with the elements of the new solution set. If students do believe that Equivalence Classes could be used to solve all questions for which posing a new problem is productive, they may experience a perturbation. Ratio thinking could emerge as a result of the resolution of such perturbation.

7.2.4.1. Perturbation because of limitation of Equivalence Classes

Emily might believe that Equivalence Classes could be used in any situation for which Deletion thinking is appropriate. She may experience a perturbation if she poses a new question but cannot partition the solution set of this new question into blocks which exist in bijective correspondence with the elements of the original solution set. Al experienced such a perturbation in the eighth session of the second phase.

7.2.4.1.1. Example from the data (Al)

At the beginning of each session of this study, students were asked to summarize what had happened in the previous session. The purpose of this discussion was to have the students recall the tasks they had previously seen and discuss their ways of approaching those problems by using their written work as a reference. At the beginning of the eighth session of the second phase, Al's response to the request to summarize the previous session was that he was introduced to the idea of dividing to "simplify problems." At this point in the study, the only way of thinking which involved division was Equivalence Classes. Therefore, it seems likely that Al's take-away from the previous session was the use of Equivalence Classes. In fact, Equivalence Classes had been introduced in the fifth session, but had been implemented Devil's Advocates in sessions 6 and 7 as well. In addition, Al had engaged in Equivalence Classes on his own in sessions 6 and 7.

Al elaborated on his statement about the introduction of division for simplifying problems by explaining that before, if there were 60 "total answers", but only 10 "unique answers," he would have to subtract 50 to find those 10. But now, he could recognize that since each unique answer was "permutated 6 times," he could divide by six to find the 10.

Here, it seems as if the number of “total answers” was the size of a solution set to a new problem and the number of “unique answers” was the size of the solution set to the original problem. By his reference of the operation of subtraction, it is clear that Al was discussing Deletion thinking in his previous solution. Again, his reference to division is indicative of Equivalence Classes. Thus, it seems as if Al could be claiming that Equivalence Classes could be implemented whenever Deletion could be.

However, it is not true that Equivalence Classes can be implemented in place of Deletion. Consider Task 2: Dice which involves determining the number of rolls of a red die and a white die which are not doubles. Here, a student must determine the number of outcomes that are not doubles from one red and one white die. It is not possible to pose the problem “How many total outcomes are there?” and partition the solution set to this question into equivalence classes, each of which exists in bijective correspondence with the elements of the original solution set. If it were possible, the size of the original solution set would need to be a factor of the size of the new solution set. In this case, however, there are 36 elements in the new solution set, and only 30 elements in the original one.

The researcher intended to use Task 2: Dice to point out that Equivalence Classes is not always applicable in problem posing situations and that Deletion could be in those situations. After Al was reminded of the statement of the Dice task, he first engaged in Odometer thinking and found the answer to be 6×5 . He then continued as shown in the following excerpt.

Excerpt 22. Revisit Task 2: Dice in P2_S8

AI: I guess another way to approach it is you could say using subtraction, you could say there ways in the first roll, six ways in the second roll but there are also six repetitions (writes “ $6 \times 6 - 6$ ”). For division, you could say six ways to do the first, six ways to do the second (writes “ 6×6 ”) and for every six rolls (writes a line under the multiplication), only five are good so you would divide by... (scratches out division line) [pause].

In the first sentence of Excerpt 22, it seems as if AI first posed a new problem which involved determining the total number of rolls possible with red and white dice. His use of subtraction indicates that he engaged in Deletion thinking to determine the solution to the original problem. Because his next sentence was regarding “division,” it seems as if AI attempted to engage in Equivalence Classes for this same problem. It appears as if AI believed, at least for this problem, that Deletion and Equivalence Classes would both yield correct solutions for this task. However, when he scratched out the division line, it appears that he realized division, and therefore Equivalence Classes, was not appropriate for this problem. His pause could indicate a moment of perturbation.

7.2.4.1.2. Comparison to Emily

If Emily believed that Equivalence Classes could always be used in place of Deletion thinking, she, like AI, could experience some perturbation when she realizes division is not appropriate for the Dice problem even though subtraction is. She might

then realize a limitation of Equivalence Classes thinking and recognize that Equivalence Classes is not always appropriate when Deletion is.

7.2.4.2. Ratio as an accommodation of Equivalence Classes

Emily, after recognizing a limitation of Equivalence Classes from her experience with the Dice problem, might resolve her perturbation by accommodating and developing Ratio thinking. Al did exactly this. The following example was included in Section 7.1.3 above. However, it is included again for clarity. In the earlier subsection, the data served to explain Ratio thinking. Here, it serves to show how Al resolved his perturbation.

7.2.4.2.1. Example from the data (Al)

After Al realized that Equivalence Classes was not appropriate for the Dice problem, scratching out his division bar, he continued as shown in Excerpt 23.

Excerpt 23. Revisit Task 2: Dice in P2_S8

Al: For every six rolls (writes a line under the multiplication), only five are good so you would divide by... (scratches out division line). I guess you could multiply it by five over six (writes $\frac{5}{6}$ after the 6×6). I guess it's trying to figure out [...] what fractions of the answers you have are [not] repetitions, and you are trying to find that fraction and you could multiply it by that

As discussed in the Ratio subsection above, Al was not familiar with quantifiers, so when he said "*for every six rolls*," it is unlikely that he was actually referring to every subset of size six of the new solution set. Instead, it appears he had partitioned the new solution set into groups of six (perhaps based on the number on one of the die). He then

considered the ratio of the number of elements which were wanted in that block to the total number in the block. This is supported by his claim that for each six, only five were “good.” Since this was true for each block, he realized that the original solution set was $\frac{5}{6}$ the size of the new solution set. He therefore multiplied the cardinality of the new solution set by $\frac{5}{6}$ to find his final answer. He resolved his perturbation regarding Equivalence Classes making an accommodation and developing Ratio thinking.

7.2.4.2.2. Comparison to Emily

Emily, if never presented with a task for which the solution set of a problem she poses cannot be partitioned in blocks of the same size that are in bijective correspondence with the elements in the original solution set, might continue to believe that Equivalence Classes is applicable whenever Deletion is. However, it is possible that Emily could develop Ratio thinking on her own when presented with a such task. For example, she, like Al, could experience perturbation and develop Ratio thinking when presented with the Dice problem. If she did not engage in Ratio thinking on her own, it is likely that through discussion with the researcher or a Devil’s Advocate driven by Ratio thinking, she would resolve her perturbation and develop Ratio thinking.

7.3. Visualizations of Problem Posing Thinking

This section discusses visual representations which could be used to represent Problem Posing thinking. Some examples of representations for these ways of thinking are above – a visualization of Equivalence Classes was shown in Figure 29 and Ratio thinking was shown in Figure 31. This section focuses on the visualizations which were used in this study – those employed by the students, and those which were introduced through the tasks in the study. First, two visual representations of Deletion thinking are

presented, both of which were seen after AI transferred Venn diagrams from Subsets thinking. Then the three visual representations of Equivalence Classes used in this study are presented: (1) tables and (2) mapping diagrams which were introduced to the students and similar to Figure 33 and Figure 29, respectively, and (3) Venn diagrams which AI transferred from Deletion thinking to Equivalence Classes.

7.3.1. Visualization of Deletion

While Kate and Boris certainly engaged in Deletion thinking, they did not indicate that they were associating any visualization with this way of thinking. AI, on the other hand, employed two different visual representations for Deletion thinking. Both of them involved Venn diagrams – the first had superfluous aspects and the second involved the use of the universal set.

7.3.1.1. Venn Diagram representation with superfluous aspects

Consider Task 14(vi): Letters $abcdef$ whose statement is below.

- Situation: Suppose we have the letters a, b, c, d, e, f and we are forming three-letter strings of letters (“words”) from these letters.
- Question: How many 3-letters “words” can be formed from these letters if repetition of letters is not allowed and either the letter “ d ” must be used or the letter “ a ” must be used, or both must be used?

As described in Section 5.3.1.2 above, AI first over counted and found that there were $36+36+36$ “words” by arguing that “ d ” could go in one of three spaces, and for each of those options there were 6×6 ways to fill the remaining slots. Devil’s Advocate

was used to provide the following argument for Task 14(vi) – it is driven by Deletion thinking and attributed to a supposed former student, Carrie:

Carrie's argument: We first determine the number of 3-letter “words” possible regardless of whether “*d*” is used: $6 \times 6 \times 6$. Then, we determine the number of “words” which do not include “*d*”: $5 \times 5 \times 5$. Thus, there are $6^3 - 5^3 = 91$ “words” which include the letter “*d*.”

He was asked to evaluate Carrie’s argument and he experienced perturbation because he felt it was correct though it yielded a different solution than his original solution. Al eventually realized that if Carrie’s argument were correct, then he had originally over counted and began to look for elements which may have been counted more than once. Once he found these elements, he adjusted by engaging in Addition thinking, as discussed in Section 5.3.1.2 above.

After Al resolved his perturbation, he was asked if he had seen an argument like Carrie’s before. The intention of the question was to address the aspects of the underlying way of thinking – Deletion – in which he had naturally engaged for several previous problems; however, his response, shown in Excerpt 24, did not refer to any alternative argument but to Venn diagrams:

Excerpt 24. Task 14(vi): Letters abcdef from P2_S5

Al: It’s kind of like the Venn diagram but it’s kind of not. [...] It’s kind of like the Venn diagram, ’cause in the Venn diagram you have kind of these two circles (draws the two circles in Figure 34), but she was saying that is with ‘*d*’ (writes

“*d*” in the portion in the right circle that is not in the left circle) and then this is with all the possibilities without ‘*d*’ (writes “*d*” in the portion in the intersection of the circles). So she just kind of ignored this (scribbles in the portion of the left circle that is not in the right circle)...this is all the possibilities with ‘*d*,’ (indicates the entirety of the right circle) then she subtract[ed] the [possibilities] without a ‘*d*’ to figure out how many just have ‘*d*’

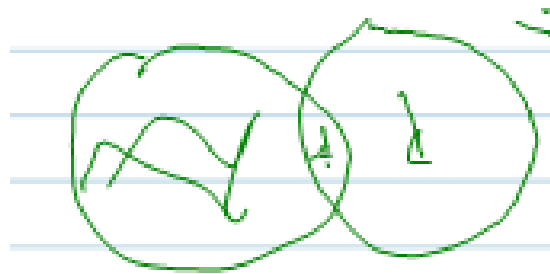

Figure 34. Al’s Venn diagram for Deletion thinking from Task 14(vi)

At this point in the study, the Venn Diagram Activity had been implemented with two sets for Ian’s argument for Task 14(iv) (see Section 5.3.1.1 above). In that situation, the Venn diagram involved two sets with a non-empty intersection. Thus, Al’s representation for Carrie’s reasoning was based off the Venn diagrams he had seen before and therefore involved two sets with a non-empty intersection.

Al’s visual representation for Carrie’s Deletion thinking involved counting everything in the right circle of Figure 34 and then subtracting the number of elements in the intersection. Thus, it seems as if Al understood that Carrie constructed a new problem (that of determining the total number of 3-letter words) and then found an additive relationship between the new solution set and the original solution set, even though his Venn diagram included unnecessary visual elements.

7.3.1.2. Venn Diagram representation with universal set

During the eighth session of Phase 2, Al employed a slightly different visualization to represent his reasoning for Deletion thinking. Consider Task 30(v):

Wellesley:

- Situation: Consider the word WELLESLEY. We will be forming “words” from these letters.
- Question: How many “words” can be formed from the letters in “WELLESLEY” if we need 4-letter words, each letter may be used multiple times, and we must use the letter “E”?

At first, Al over counted and found the answer to be $\binom{4}{1} \cdot 5^3$ because he considered places the E could go and then determined that there 5 choices for each of the remaining spots. The researcher reminded Al that he should ensure that he had counted everything he wanted to count and that he had not counted the same thing more than once. He quickly realized his mistake and determined the solution to be $5^3 + 5^2 \times 4 + 5 \times 16 + 4^3$ by engaging in Union thinking with subsets determined by the location of E and then carefully ensuring he had not over counted the intersections of these subsets. He explained that the researcher’s utterance reminded him of the “Venn diagram problem and that kind of whole picture (draws a diagram with 4 overlapping circles) just popped into my head.” It is not possible to draw a true diagram that shows all possible logical relations between finite sets of elements using circles and so a true “Venn diagram” for 4 sets would require ellipses or some other figures. However, to Al, this was not a factor in his creation of the representation. He was not truly visualizing all of these relations, but

using the visual image to represent the fact that the relationships exist. It is clear that he was envisioning a version of a Venn diagram for Union thinking although he did not draw it while counting.

The researcher reminded Al of Carrie’s Deletion argument for Task 14(vi). He was not asked to do so, but Al engaged in Deletion thinking for Task 30(v), saying “So in this case, it would be $5^4 - 4^4$.” At this point, the researcher introduced the Venn diagram shown in Figure 35, explaining that the box represented the whole universe that the researcher and Al were concerned with. Mimicking Al’s previous diagram used for Task 30(v), she sketched the four circles representing subsets based on the location of E. The researcher asked Al what was actually being counted in each term of his solution. Al quickly responded that the entire box was being counted and then everything that was not in the circles was being subtracted. Thus, another visual representation Al could have used for Deletion thinking was a Venn diagram with a universal set.

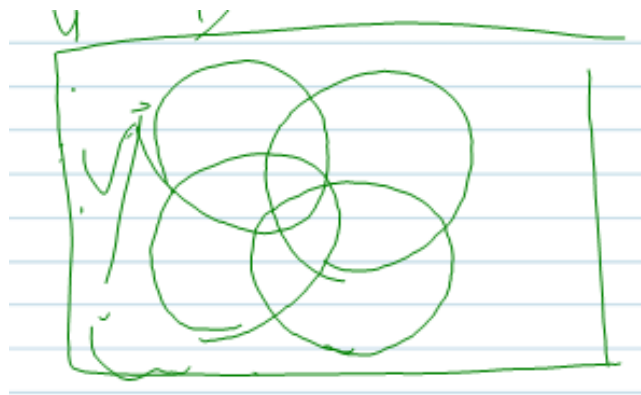

Figure 35. Venn diagram for Deletion thinking for Task 30(v)

7.3.2. Visualization of Equivalence Classes

There were three visual representations employed in this study for Equivalence Classes. Two of them, tables and mapping diagrams were introduced through various Devil's Advocates. The third, Venn diagrams, was transferred by AI from Deletion to Equivalence Classes.

7.3.2.1. Visualizations introduced to students

This subsection describes the two visual representations introduced to students for Equivalence Classes through this study: tables and mapping diagrams.

7.3.2.1.1. Tables

One visual representation introduced for Equivalence Classes during this study involved tables which were organized so that each row corresponded to an equivalence class of the new solution set. This representation was introduced in Task 18: Table, the first task with a solution driven by Equivalence Classes as shown in Figure 33. Tables were also in the Devil's Advocates in other tasks such as Task 22: Smoothie. The idea of using tables as a representation arose when Sara in Pilot Study 1 chose to use them.

Sara saw a version of Task 18: Table which was phrased as follows in Pilot Study 1: "*Situation*: A bunch of people would like to sit around a large, round table. It doesn't matter to them which particular seat they sit in, but they do care about the people who will be sitting to either side of them. *Question*: In how many ways can n people sit around a circular table?" Prior to solving this version of the Table problem, Sara had successfully constructed the operation of permutations by investigating the number of ways to arrange n distinct cards in a row. She thought that it was the same as arranging the cards in a row

so that there would be $3!$ ways to place 3 people around the table. She labeled each person a different letter and drew representations of the arrangements. Perhaps due to the awkward phrasing of the situation, Sara did not realize that rotations of the table would yield the same table arrangement when she was first presented with the Table problem. However, as discussed in Section 7.2 above, even when Boris saw the revised version of the same task in which the situation is better described, he also initially believed the question to be analogous to arranging people in a line. These results indicate that though the mathematics community might interpret a task in one way, students could interpret it in another. This is consistent with the results of Godino et al. (2005).

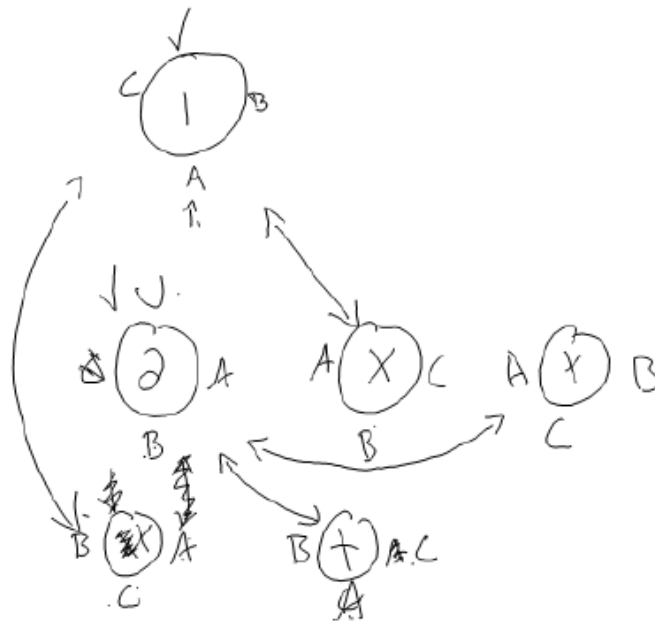

Figure 36. Sara's diagram for the Table problem with three people

Sara was then asked to explain her interpretation of the situation again. By re-reading the statement of the task, Sara realized a rotation would yield the same table arrangement. She looked at her drawing of the 6 circles and began to put \times or \checkmark by each

circle depending on if it were something she had not yet counted. In order to clearly see her thought processes as she went through the problem, the researcher suggested that she put an arrow between circles with ✖ and the circle with ✓ to which they corresponded. She determined that there were 2 ways to place 3 people around the table. Her work can be seen in Figure 36. It is entirely possible that by suggesting that she draw those arrows, the researcher encouraged Sara to consider table arrangements as equivalent.

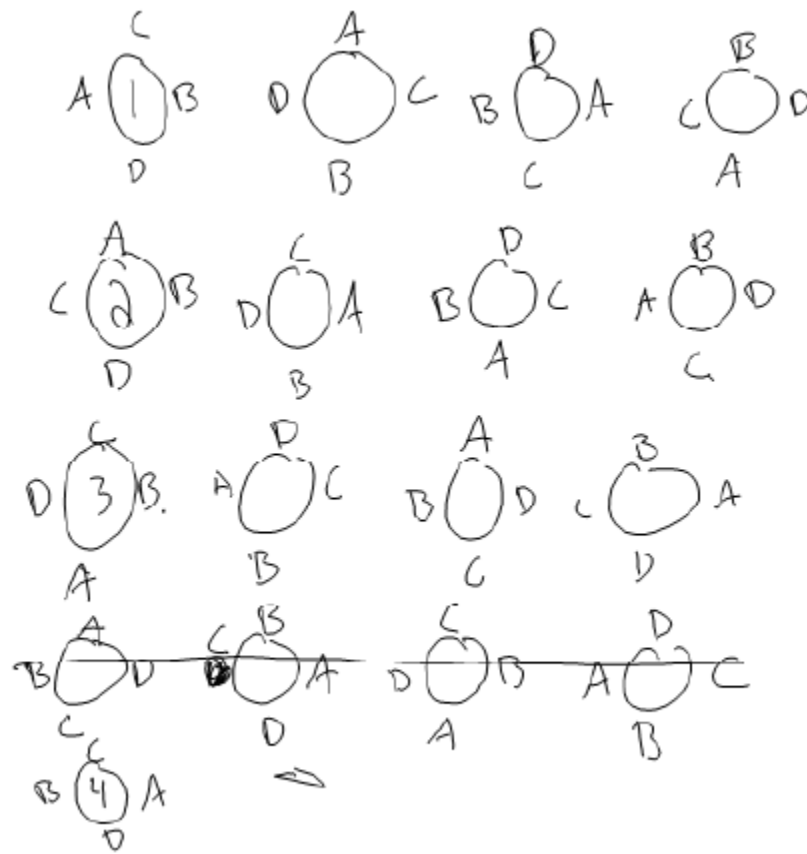

Figure 37. Sara's diagram for the Table Problem with four people.

Sara then proceeded on to arranging 4 people around the table. As she had ultimately done for the 3-person problem, she constructed a new problem in which rotations of the circle were not considered equivalent. She grouped the tables so that each

row corresponded to a table arrangement she wanted to count, as can be seen from Figure 37. Once Sara had drawn four different rows, she realized that the answer for the four person problem would be six and drew only one representative for the remaining two groups [not shown].

The idea for the representation attributed to the “former student” Pat in Figure 33 presented to the students in this study arose from Sara’s representation in Figure 37. As mentioned earlier, tables similar to Figure 37 were also used as PCTs in alternative arguments presented for other tasks in this study (see Appendix A for these arguments).

The students in this study used tables a couple times to represent their reasoning as they engaged in Equivalence Classes. Indeed, Kate and Boris employed a table to visualize their solution to Task 21: Necklace, which involved the operation of circle permutations:

- Situation: Amy has a bunch of beads to place on a necklace. Each bead has a different color.
- Question: In how many ways can Amy place n beads on the necklace?

In both the Table problem and the Necklace problem, the new problem of permuting n distinct items was posed by the students. From a mathematics standpoint, in contrast to the Table problem for which only rotations of these permutations were considered equivalent, the Necklace problem requires reflections and rotations of these permutations to be equivalent. Working with $n=4$, Kate and Boris first constructed the first row shown in Figure 38. The elements listed are permutations of the letters {A, B, C, D} and the row consists of rotations of ABCD. They then created the first column in

Figure 38. Though at this point they had not filled out the entire table, it is clear that they could have done so and were envisioning a full table.

21	ABCD	BCDA	LDAD	DABC
	ABDC	BACD	CDAB	ABCD
	ABDC	ABCDA	DCAB	ABCD
	ACBD	CBDA	BDAC	DACB
	ACDB	CDBA	BBAC	DABC
	ADBC	DBCA	BLAP	CADB
	ADCB	DCBA	CBAD	BAPC

Figure 38. Kate and Boris' table representation for Task 21: Necklace

Kate and Boris then attempted to identify which of these elements should be discarded because they were reflections of an element already listed. At this point, the researcher suggested that they list out all of the elements of the new solution set. They did so, as can be seen from Figure 38. Next they identified rows which would be considered equivalent. For clarity, the researcher suggested that they draw arrows between them, just as Sara did in Figure 36.

Kate and Boris' representation shows that they were engaging in Equivalence Classes twice. First, they posed the new problem of permuting elements n distinct elements. They grouped the elements in this solution set based on whether the permutations would form the same table arrangement, which implicitly required the students to pose the problem of arranging n people around a table. Next, they identified which table arrangements would form the same necklace and grouped them by drawing arrows between the rows of the table.

Al also used tables to visually represent his Equivalence Classes thinking when he explained the derivation for the formula for combinations from arrangements:

$$\binom{n}{k} = \frac{n(n-1)(n-2)\cdots(n-k+1)}{k!}. \text{ His table was very similar to the one introduced in the}$$

Devil's Advocate for Table 22: Smoothie (see Appendix A). However, he only filled out the first row and first column of his table. It was clear that he was envisioning the rest of the table, even though he did not show it.

In this study, all three students in this study employed tables as visualizations associated with Equivalence Classes after they were introduced through Devil's Advocates. Also, there is evidence from Sara in Pilot Study 1 that students could spontaneously use this representation even if it had not been introduced to them through instructional interventions.

7.3.2.1.2. Mapping diagrams

Another visualization for Equivalence Classes which was introduced to students through this study was *mapping diagrams*. Though this representation was introduced in this study to help students visualize when Equivalence Classes was used for multiple newly-posed problems, none of the students in this study employed mapping diagrams themselves. Still, it is included in this Section for completeness of the various visual representations used in this study for Equivalence Classes.

For example, consider Task 28: Projects, Bat 7, Part, which was modified from Batanero et al. (1997b):

- Situation: Four friends Ann, Beatrice, Cathy and David must complete two different projects: one in Mathematics and the other one in Language. They decide to split up into two groups of two pupils, so that each group could perform one of the projects.
- Question: In how many different ways can the group of four pupils be divided to perform these projects?

A solution to this task presented through Devil's Advocate, which was attributed to a former student named Vince, is below:

We can think of this task as passing out the letters $L L M M$ to the students. Say the first letter gets passed to Ann, the second to Beatrice, the third to Cathy and the last to David. Then, we have the problem of ordering $L L M M$. Now, if we had 2 different Language projects and two different math projects, we could call them L_1, L_2, M_1, M_2 . Then, we would have 4 distinct objects to permute in 4! ways. But, $L_1 L_2 M_1 M_2$ is the same as $L_2 L_1 M_1 M_2$. In both of them, Ann and Beatrice would work on Language. So we can write $L_1 L_2 M_1 M_2$ as $LLM_1 M_2$.

Notice that this is because there are $2!$ times more ways to arrange L_1, L_2, M_1, M_2 than there are to arrange L, L, M_1, M_2 . So, we divide $4!$ by $2!$ to compensate. But

$LLM_2 M_1$ is the same as $LLM_1 M_2$. By the same argument, we have to divide $\frac{4!}{2!}$

by $2!$ again. See below:

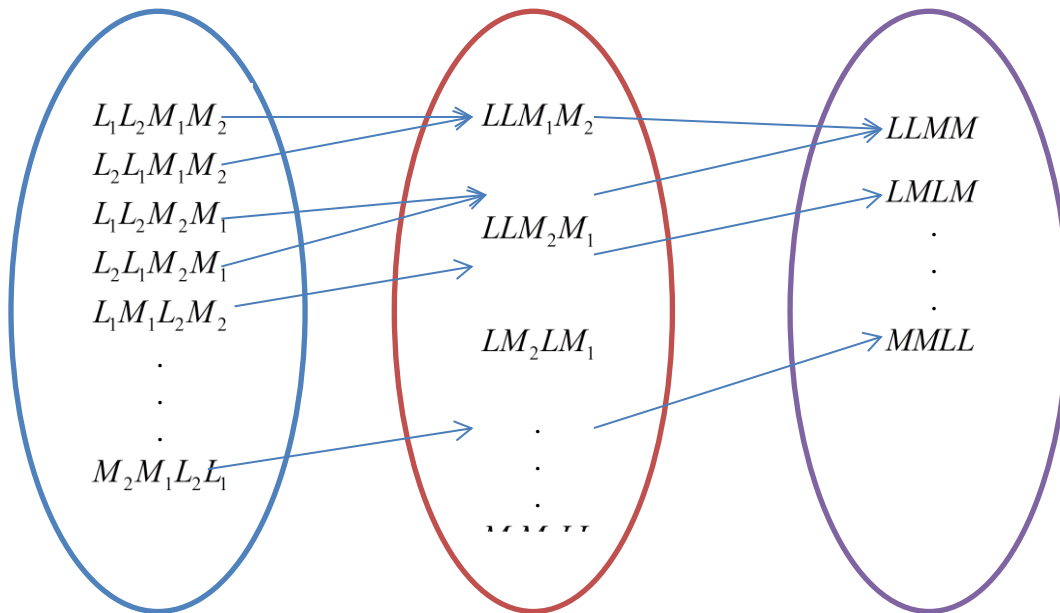

Figure 39. Mapping diagram for Vince's argument for Task 28

In Phase 1, Kate and Boris were accidentally presented with a version of Figure 39 in which the formatting was not correct. The elements in the blue solution set were double spaced when they should have been single-spaced and the arrows therefore did not align correctly. Both students were able to fix the diagram and determine the correct mapping, indicating that they could connect the visual image with Equivalence Classes.

As mentioned previously, mapping diagrams were not used by the students, even though they were a primary PCT used in various alternative arguments presented to the students. Given the prevalence of students' other visual representations, the lack of mapping diagrams as a representation adopted by students is surprising.

7.3.2.2. Venn diagrams

The third visual representation for Equivalence Classes in this study is Venn diagrams. This representation was not introduced to students for Equivalence Classes.

Instead, it was seen during this study when AI transferred the use of Venn diagrams with a universal set from Deletion thinking to Equivalence Classes.

In the last session of the second phase, the researcher asked AI to give some examples of visual representations. His response regarding Venn diagrams is below:

Excerpt 25. Discussion of visual representations from P2_S9

AI: There's been kind of Venn diagram style overlap (draws the Venn diagram with a rectangle and three circles shown in Figure 40) and then there's been kind of a way that you could also figure that out by taking the whole (indicates entire rectangle) [...] and then you're dividing out [...] this kind of bad area (shades in the complement of the three circles, shown in grey) [...] Because when it comes to situations with [...] a lot of different overlaps [...] like if there's a fourth circle (draws the fourth circle in the figure, shown in grey) [...] then it'll get kind of complicated and so it would almost be easier to kind of find the whole thing and then kind of take out the stuff you don't want [...] [by dividing]

To AI, the universal set in Figure 40 is the solution set to a different problem, one which involves both things that he wants to count, represented as the union of the circles, and things that he does not want to count. In the previous session discussed in Section 7.3.1.2 above, AI determined an additive relationship between the solution set of the original problem and that of the new problem, representing the former with the universal set and the latter contained within the universal set. In his explanation about a generic problem, AI could imagine a multiplicative relationship existing instead and using the ratio to solve the problem. There are very few differences between the Venn diagrams in

Figure 35 and Figure 40; however, Al was using them to represent reasoning with different bases – additive in the former, and multiplicative in the latter.



Figure 40. Al’s Venn Diagram for Equivalence Classes thinking from session 9

Al then demonstrated his use of Venn diagrams to represent his multiplicative reasoning in a specific problem. He had previously engaged in Equivalence Classes to determine that there are $\frac{11!}{4! \cdot 4! \cdot 2!}$ permutations of the letters in MISSISSIPPI. At this point, he returned to the problem and explained that there were $11!$ ways to permute 11 distinct items and drew a rectangle to represent these $11!$ elements. He then drew an oval in this rectangle, stated that we only wanted the valid answers, and wrote “g” for “good” inside the oval. He explained that for each “good” thing there were $4!$ ways to rearrange the Ss, $4!$ ways to rearrange the Is and $2!$ ways to rearrange the Ps. He stated that $4! \cdot 4! \cdot 2!$ was “how many times more answers we have than we have valid answers” while shading in the complement of the set “g.” He summarized his approach:

Excerpt 26. Task 31: Mississippi II from P2_S9

Al: I knew if I were to attempt to try to find what's inside the 'g' by itself, it's kind of hard. But I realized that if I were able to find everything [...], it would be a bit easier.

For this problem, Al first realized that he could pose a different problem – that of permuting 11 distinct objects, representing its solution set with a universal set. This concept of a universal set was something that Al seemed to connect with posing a new problem, even though it was introduced for the additive Deletion thinking in session 8, not multiplicative Equivalence Classes thinking. He then determined that there were $4! \cdot 4! \cdot 2!$ of these elements which corresponded to each element he actually wanted to count, representing the set of “valid answers” as a subset of the universal set. It is interesting to note that in the Venn diagram for Task 30(v): Wellesley, the set of “words” which do not use “E” is a subset of the total number of words and they were represented as such. In Task 31(i): Mississippi II, on the other hand, the set of permutations of MISSISSIPPI is *not* a subset of the set of permutations of 11 distinct items. However, there is a subset of 11 distinct items that exist in a bijective correspondence with the set of permutations of MISSISSIPPI. This subtlety did not appear to occur to Al. It is clear that he visualized a Venn diagram with a universal set containing a proper subset to explain the multiplicative reasoning he employed while engaging in Equivalence Classes for this problem.

8. DISCUSSION AND CONCLUDING REMARKS

This research attempted to contribute to the underdeveloped field of combinatorics education by studying students' reasoning about enumerative combinatorics problems and how students conceptualize the set of elements being counted in such problems, called the *solution set*. In particular, this research focused on the stable patterns of reasoning, known as *ways of thinking* (Harel, 2008), that students applied in a variety of combinatorial situations and tasks. This study catalogued students' ways of thinking about the solution sets as they progressed through combinatorics tasks involving arrangements with and without repetition, permutations of distinct elements, combinations, and permutations with repeated elements. In addition, it explored relationships between the catalogued ways of thinking. Further, it investigated the challenges students experienced as they interacted with the tasks and instructional interventions, and how students' ways of thinking evolved as these challenges were overcome. Finally, it examined the role of instruction in guiding students to develop and extend their ways of thinking.

This study engaged four undergraduate students with no formal experience with combinatorics in one of the two consecutive teaching experiments conducted in Spring 2012. The analysis of the study focused mainly on the data from the three students who completed all of the tasks designed for the study. Many ways of thinking emerged through the grounded theory analysis (Strauss & Corbin, 1998) of the data, but only eight were identified as robust. The robust ways of thinking were classified into three categories: Subsets, Odometer, and Problem Posing. The *Subsets* category is comprised of two ways of thinking, both of which ultimately involve students envisioning the

solution set as the union of subsets, that they may believe to be disjoint. The three ways of thinking in *Odometer* category involve students holding an item or a set of items constant and systematically varying the other items involved in the counting process. The ways of thinking belonging to *Problem Posing* category involve students posing new, related combinatorics problems and finding relationships between the solution sets of the original and the new problem. The evolution of students' ways of thinking in the Problem Posing category was analyzed using Piaget's (1980, 1985) Theory of Knowledge development. This entailed examining the perturbation experienced by students and the resulting accommodation of their thinking. It was found that such perturbation and its resolution was often provoked by an instructional intervention.

This chapter synthesizes the results of this study in terms of the research questions posed in Section 1.2:

1. What are students' ways of thinking about combinatorics solution sets?
2. What are the relationships between students' ways of thinking about combinatorics solution sets?
3. To what extent do students' ways of thinking about combinatorics solution sets evolve as the students resolve the challenges they experience as they interact with tasks and instructional interventions?
4. In what ways, and to what extent, might students be guided to develop and extend their current ways of thinking about combinatorics solution sets?

Concisely, these research questions involve 1) cataloguing students' ways of thinking about solution sets observed by the researcher, 2) examining the relationships between such ways of thinking, 3) describing the evolution of students' ways of thinking, and 4)

exploring the role of the instructor in the development of students' ways of thinking, respectively. This chapter next discusses implications of this study for the teaching and learning of combinatorics. Finally, this chapter describes some avenues for future research which could build upon the results of this study.

8.1. Results in Terms of Research Questions

This section connects the results of this study to the four research questions the study intended to investigate. The first four subsections below are organized based on the four research questions posed above. The last subsection addresses the limitations of this study in relation to the research questions.

8.1.1. Cataloguing students' ways of thinking about solution sets

This Section addresses the first research question: "1. What are students' ways of thinking about combinatorics solution sets?" By examining students' utterances and actions, the researcher posed general conjectures to explain students' reasoning. These conjectures were informed by an initial framework of ways of thinking created from the results of pilot studies. From these conjectures, she abstracted the general behaviors exhibited by students through the course of the study, which facilitated the identification of ways of thinking which explained those behaviors.

Many ways of thinking emerged from the data analysis of this study. The researcher then analyzed the emergent ways of thinking based on two criteria, applicability and strong cognitive root, and identified eight robust ways of thinking which satisfied both criteria. The criterion of *applicability* requires that a way of thinking must be applicable to solve multiple tasks. The *strong cognitive root* criterion meant that the

way of thinking would provide students with the means to reason about the elements of the solution set and the relationships between the elements, and that this way of thinking could be transferred to other tasks. Examples of how these criteria were applied can be found in Section 4.5.3.1, which discusses some non-robust ways of thinking.

The eight robust ways of thinking identified in this study and their characterizations are below.

- *Addition*: First, think locally, consider a subset of the solution set, find its size. Second, consider another subset of the solution set and find its size. Then, continue this process until exhaustion of the elements of the solution set.
- *Union*: Consider the entire solution set and envision it as the union of subsets. Then, count the size of the solution set.
- *Standard Odometer*: First, determine the number of items which could be placed into a given position. Then, for each of those placements, determine the number of ways to place items in an effort to construct the entire solution set. In essence, hold different items constant in a given position while varying items in the other positions.
- *Wacky Odometer*: First, determine the number of positions in which a given item could be placed. Then, for each of those placements, determine the number of ways to place items in an effort to construct the entire solution set. In essence, hold the same item constant in different positions while varying items in the other positions.

- *Generalized Odometer*: First, select a set of items to be held constant. Next, determine the number of ways to place these items in slots. Third, for each of those placements, systematically vary items in the other slots in an effort to construct the entire solution set. In essence, hold the same set of items constant in different positions while varying items in the other positions.
- *Deletion*: First, consider a given problem. Second, pose a related problem whose solution set contains a subset which has a bijective correspondence with the solution set of the original problem. Third, find an additive relationship between the solution sets. Fourth, find the cardinality of the new solution set. Next, determine the size of the complement of the subset of the new solution set which corresponds to the original solution set. Finally, use the additive relationship to quantify the size of the original solution set.
- *Equivalence Classes*: First, consider a given problem. Second, pose a related problem with a solution set which can be partitioned into blocks of the same size – each one of which is in a bijective correspondence with an element of the original solution set. Third, find a multiplicative relationship between the solution sets. Next, quantify the size of the new solution set and of each block. Finally, use the multiplicative relationship to quantify the size of the original solution set.
- *Ratio*: First, consider a given problem. Next, pose a related problem with a solution set which can be partitioned into blocks of the same size – each one of which has the same number of “wanted” elements which are in a bijective correspondence with elements of the original solution set. Third, quantify the

size of the new solution set. Fourth, find the ratio of “wanted” elements to total elements in each block. Finally, use this ratio to determine the size of the original solution set.

8.1.2. Relationships between students’ ways of thinking

This subsection addresses the second research question: “2. What are the relationships between students’ ways of thinking about combinatorics solution sets?” In order to answer this research question, the researcher examined all of the ways of thinking which emerged from the data analysis of this study. From there, the robust ways of thinking were grouped into categories based on common characteristics: Subsets, Odometer, and Problem Posing. For each of these categories, the characteristic unifying the ways of thinking within the category, along with the similarities and differences between the ways of thinking included in the category are discussed below. Some non-robust ways of thinking were found to belong to the Odometer and Problem Posing categories.

8.1.2.1. Subsets category

The Subsets category consists of two robust ways of thinking, Addition and Union, which ultimately involve envisioning the solution set as the union of smaller subsets. Both of these ways of thinking are described in Section 8.1.1 above. This category is discussed in more detail in Chapter 5.

In both Addition and Union, if the subsets comprising the solution set partition the solution set, the size of the solution set is the sum of the sizes of the subsets. Thus, a typical indication that a student is engaging in either of the Subsets ways of thinking is

the use of the addition operation. However, if the subsets partitioning the solution set contain the same number of elements, the final expression might involve the multiplication operation. If a student envisions the solution set as the union of subsets that are not disjoint, but is not attentive to the non-empty intersections, the student may over count the size of the solution set.

Essentially, Subsets thinking involves breaking the solution set into subsets, each of which satisfies a specific case. Addition thinking takes a local approach to problem solving, whereas Union takes a global one. In the context of combinatorics, a local approach would be to consider only part of a solution set at a single time, whereas a global approach would be to consider the entire solution set. In other words, Addition involves first considering a single case and determining the number of elements which satisfy that case before considering any other cases; in contrast, Union involves breaking the problem into cases first, before finding the number of elements which satisfy each case.

8.1.2.2. Odometer category

The Odometer category consists of ways of thinking which involve holding an item or set of items constant while systematically varying items in other slots. This category extends the odometer strategy from English (1991). Standard Odometer, Wacky Odometer, and Generalized Odometer emerged as robust ways of thinking belonging to this category (see Section 8.1.1 above for their descriptions). For a detailed discussion of the robust Odometer ways of thinking, see Chapter 6. For an example of non-robust Odometer thinking, see Section 4.5.3.1.1.

In all three robust Odometer ways of thinking, the student would first figure out the number of ways to place either an item or set of items. For each of those placements, the student would then determine the number of ways to place items in the other positions. When determining the number of ways to place items in other slots, a student could hold the original item or set of items constant. Often, the number of ways to place the items in the other positions is the same for each of the original placements. If this is the case, then the size of the solution set can be determined by multiplying the number of original placements with the number of ways to vary the other items. Therefore, the operation of multiplication in a final expression for the size of a solution set often indicates that an Odometer way of thinking could have driven the solution.

One difference between the Odometer ways of thinking comes from whether an item or a set of items is being held constant. When engaging in *Standard Odometer* and *Wacky Odometer*, the student first places an item and holds it constant; in contrast, in *Generalized Odometer*, the student first places a set of items and holds it constant. Another difference between the Odometer ways of thinking is whether the student's focus is on items or positions. In *Standard Odometer*, the focus is on a given position – the student would hold items constant in that given position and, for each of those placements, vary the items for the other positions. In *Wacky Odometer*, the focus is instead on a given item – the student would hold the item constant in different positions and, for each of those placements, vary the other items in the other positions. In *Generalized Odometer*, the focus is on a set of items and the ways in which these items could be placed.

8.1.2.3. Problem Posing category

The Problem Posing category consists of ways of thinking which involve posing a new counting problem and using the new solution set to find the size of the original solution set. During this study, three Problem Posing ways of thinking were identified as robust: Deletion, Equivalence Classes, and Ratio. These three ways of thinking are described in Section 8.1.1 above, and discussed in detail in Chapter 7. Another way of thinking, Weak Problem Posing, belongs to this category. However, since it failed the strong cognitive root criterion, it is not considered a robust way of thinking. See Section 4.5.3.1.3 for more details about Weak Problem Posing.

All of the robust Problem Posing ways of thinking involve posing a new question and quantifying the size of its solution set. Under *Deletion*, the new solution set would contain a subset which is in one-to-one correspondence with the original solution set, and an additive relationship between the two solution sets would be determined. Indeed, by finding the size of the new solution set, a student could subtract the size of the complement of the subset to find the size of the original solution set. Thus, a typical indication that Deletion thinking could be driving a solution is the use of the subtraction operation in the final expression. In contrast to Deletion, under *Equivalence Classes* and *Ratio*, the new solution set would be partitioned into blocks of the same size and a multiplicative relationship between the two solution sets would be determined. In the first case, each block would correspond to an element of the original solution set, and the student could divide the size of the new solution set by the size of the block to find the size of the original solution set. Thus, a typical indication that Equivalence Classes could be a driving force in a solution is the use of the division operation in the final expression.

In the second case, each block would contain the same number of “wanted” elements which would correspond to elements of the original solution set. By determining the ratio of the “wanted” elements in each block to the size of the block, the student could multiply the size of the new solution set by this ratio to find the size of the original solution set. Thus Ratio thinking may be a driving force in a solution if multiplication by a proper fraction is in the final expression.

8.1.3. Evolution of ways of thinking

This subsection addresses the third research question: “3. To what extent do students’ ways of thinking about combinatorics solution sets evolve as the students resolve the challenges they experience as they interact with tasks and instructional interventions?” From this study, it is conjectured that students’ ways of thinking in the Problem Posing category could evolve from Weak Problem Posing to Deletion to Equivalence Classes and finally to Ratio. Here, the term “evolve” is used to describe the order in which these ways of thinking might emerge in the students, but the emergence of a later way of thinking does not mean the disappearance of a previous one. For example, Deletion thinking was a pre-cursor to Equivalence Classes, but the reader should not assume that Equivalence Classes replaces Deletion thinking. In addition, the evolution from one Problem Posing way of thinking to another is conjectured to occur as the students makes an accommodation of the first way of thinking.

Figure 41 summarizes the Problem Posing ways of thinking observed from the students in this study, where “Weak PP” refers to Weak Problem Posing, a way of thinking discussed in Section 4.5.3.1.3 and described briefly below. For each of the students, the ways of thinking emerged in the order from left to right. Indeed, Kate

engaged in Weak Problem Posing for Task 1, but engaged in Deletion for Task 2 and never appeared to engage in Weak Problem Posing again. She appeared to engage in Equivalence Classes first in Task 18, and engaged in Deletion and Equivalence Classes for future tasks. Further, Boris engaged in Deletion starting in Task 2 and engaged in Equivalence Classes first in Task 18, but he also engaged in Deletion for tasks following Task 18. Finally, Al engaged in Deletion for Task 3 and later tasks, Equivalence Classes for Task 18 and later tasks, and Ratio before Task 30 and again in Task 31. Thus, the data support the conjecture of the evolution of Problem Posing thinking in the order described above and illustrated in Figure 41.

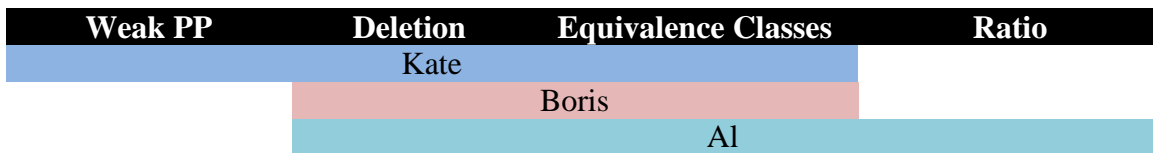

Figure 41. Evolution of Problem Posing thinking for Kate, Boris, and Al

Section 7.2 presented a model for the evolution of the Problem Posing ways of thinking for an epistemic student, Emily, with a similar background to the students from the study. This model describes limitations of Weak Problem Posing, Deletion, and Equivalence Classes. It also presents the perturbation a student might experience because of that limitation and the resulting accommodation. The viability of the model was supported by examples from the data for this study. A summary of the model follows.

8.1.3.1. Weak Problem Posing evolves to Deletion

Emily might begin by engaging in Weak Problem Posing, or Weak PP. This way of thinking involves the following mental acts: posing a new problem, generating all elements of the new solution set, identifying elements of the new solution set with

elements of the original solution set, and using this identification to list elements of the original solution set. A limitation of Weak PP way of thinking is that it required Emily to generate all possible elements of the new solution set and to list all corresponding elements of the original solution set without repetition of elements – the only way to determine the size of the original solution set would be to determine the length of the list by physically counting its length. Emily might experience a perturbation as she realizes this limitation while attempting to engage in Weak Problem Posing for tasks involving large solution sets. Emily’s Weak Problem Posing made use of a relationship between elements of the two solution sets (namely that an element of the new solution set can be identified with an element of the original solution set), but she did not find an explicit relationship, such as an additive or multiplicative one, between the two solution sets as a whole. Thus, Emily may search for explicit relationships between the solution set of a posed problem and the original problem. It is likely that she would make an accommodation and strike upon an additive relationship first, eventually engaging in Deletion thinking.

Deletion is a powerful way of thinking in which all three students in this study naturally engaged. Indeed, directly counting elements of a solution set can be tricky for students in some cases (such as Task 14(vi) as described in Section 5.2.1). Engaging in Deletion by posing a new problem whose solution set contains a subset in a bijective correspondence with the original solution set can be productive since finding the number of elements in the new solution set which are not wanted might be easier. Further, Deletion allows the students to reason clearly about the relationships between elements of the solution sets of the two problems.

8.1.3.2. Deletion evolves to Equivalence Classes

Deletion thinking is limited since quantifying the number of unwanted elements in the new solution set is not always easy. Suppose Emily poses a new problem whose solution set could be partitioned into blocks of the same size which are in a bijective correspondence with elements of the original solution set. Each block could be said to contain a single representative element, and these representative elements would form a subset of the new solution set which would be in a bijective correspondence with the original solution set. Engaging in Deletion thinking, Emily would attempt to quantify the size of the new solution set and determine the number of non-representative elements in this solution set. However, accomplishing the latter task could be non-trivial. Emily might then experience a perturbation because of this limitation of Deletion thinking. She could resolve this perturbation by determining a multiplicative relationship between the two solution sets instead of an additive one. Thus, she would develop Equivalence Classes as an accommodation of Deletion thinking. This is not to say that Emily's Deletion thinking would disappear, but rather that Emily would recognize that she could also determine a multiplicative relationship between the new solution set and the original solution set in some cases.

Equivalence Classes is a powerful way of thinking in which all three students engaged. Indeed, when solving tasks involving permutations with repetition, students might struggle to deal with the repeated items and to systematically generate all elements of the solution set. Instead of dealing with the repeated items directly, it can be helpful to pose a related problem involving distinct items and mapping the elements of the new solution set to elements of the original solution set. By engaging in Equivalence Classes

and recognizing a multiplicative relationship between the two sets, the students could clearly account for all elements of the original solution set. Here, the size of the solution set of the new problem is a multiple of the size of the original solution set.

8.1.3.3. Equivalence Classes evolves to Ratio

Equivalence Classes is limited as well – the existence of a multiplicative relationship between two solution sets does not necessarily mean that the size of the solution set of the new problem is a multiple of the size of the original solution set. Suppose Emily poses a new problem whose solution set can be partitioned into blocks of the same size which each contain the same number of elements in a bijective correspondence with elements in the original solution set. Engaging in Equivalence Classes, Emily would attempt to divide the size of the new solution set by the size of the blocks. However, it is possible that her result would not be a natural number. Emily might experience a perturbation when this occurs. Emily might then recognize that the blocks are not themselves in a bijective correspondence with the elements of the original solution set, but that only some elements of the block are. She could resolve her perturbation by determining the ratio of the number of these elements to the size of the block and multiplying the size of the new solution set by this ratio. She could thus develop Ratio as an accommodation of Equivalence Classes.

8.1.4. Role of instruction

This subsection addresses the fourth research question: “4. In what ways, and to what extent, might students be guided to develop and extend their current ways of thinking about combinatorics solution sets?” Under the philosophical standpoint adopted in this study, an instructor’s role in a mathematics classroom is to orient the students’

cognitive processes and aid them with their construction of mathematics (von Glasersfeld, 1995). In this study, the researcher accomplished this orientation through the sequencing of the tasks, the creation of sources of perturbation, and the encouragement of visual representations. First, several tasks were designed with the intention that students apply their current way of thinking to another situation through the process of assimilation. In particular, several tasks involved the same combinatorial operation, but involved different ICM (Batanero et al., 1997b). In addition, the tasks were designed to progress from arrangements without repetition, to arrangements with repetition, to permutations without repetition, to circle permutations, combinations, and permutations with repetition (see Table 4 for a summary of the progression of the operations). The circle permutations, combinations, and permutations with repetition all relied on the use of the permutation operation. It is possible that such sequencing helped students strengthen their ways of thinking by applying their current ways of thinking and operations to new tasks.

The remainder of this subsection addresses the researcher's creation of sources of perturbation and encouragement of visual representations.

8.1.4.1. Creating sources of perturbation

The researcher helped students develop new ways of thinking through the use of instructional provocations (Roh & Halani, 2011) which created sources of potential perturbation for the students, and aided in the resolution of such perturbation in some cases. In this study, Devil's Advocate was used most often for the creation of such sources of perturbation. In addition, Contrasting Prompts and Potentially Pivotal-Bridging Examples were also implemented by the researcher in an effort to create sources

of perturbation. Further, the researcher often implemented Peer Interpretations (Halani et al., 2013) during Phase 1 by asking students to reinterpret each other's arguments.

8.1.4.1.1. Devil's Advocate

The primary mechanism for the creation of perturbation was through the implementation of Devil's Advocates during critiquing activities in which students evaluated an alternative argument attributed to a supposedly former student. In this study, students first solved a given task on their own, and then encountered a Devil's Advocate argument. They were then asked to reinterpret and provide justification for the argument if they agreed with it, and refute it if they did not. These Devil's Advocates accomplished two important goals: first, they addressed students' misconceptions and second, they served to introduce new ideas to the students.

Importantly, Devil's Advocate served to address students' over counting of elements in solution sets. As described in Section 6.3.2.3.2, a Devil's Advocate driven by Deletion thinking was presented to Kate and Boris when they over counted the size of the solution set by engaging in Union thinking. By evaluating the Devil's Advocate and comparing it with their own argument, the students realized that the two solutions yielded different numerical answers and that both could not be correct. By engaging in Standard Odometer, the students were able to recognize the error in their original solution. As a result, Kate avoided over counting and engaged in Deletion thinking in a similar later task. Thus, Devil's Advocate was effective in creating a source of perturbation and in addressing over counting for Kate. Further, as mentioned in 8.1.4.2.1, several Devil's Advocates presented to Al helped Al recognize his over counting while engaging in

Subsets thinking and avoid over counting in a later problem. Thus, they served to address Al's misconceptions related to Subsets thinking.

Devil's Advocate also served to introduce new visual representations to the students. Students sometimes experienced perturbation when presented with representations which were new to them. In this study, the resolution of such perturbation meant that a new visual representation was available to them. For instance, Kate and Boris did not seem aware of tree-diagrams as a representation for Odometer thinking prior to its introduction through Devil's Advocate in Task 11. In fact, Kate seemed perturbed by the representation, stating that she did not know what it meant. Still, by Task 13, she was able to use a tree-diagram to represent her Standard Odometer thinking at the researcher's request, and in Task 14, Boris chose to use a tree-diagram to visually represent his Standard Odometer thinking.

Finally, Devil's Advocates served to introduce new ways of thinking to the students. Students experienced perturbation when presented with ways of thinking which were new to them, resolving their perturbation and developing the new ways of thinking through accommodation. For instance, none of the students engaged in Equivalence Classes thinking prior to Task 18: Table, which involved arranging n people around a table. In fact, as discussed in Sections 7.2.3.1.1 and 7.2.3.2.1, Boris was able to pose a new problem of arranging n people in a line, and partition its solution set into blocks of the same size which was each in a bijective correspondence with elements of the original solution set. However, prior to the implementation of the Devil's Advocate attributed to the former student Pat which addressed the Table problem for $n = 4$, Boris was unable to determine a multiplicative relationship between the two solution sets – he could only find

an additive one. After he was presented with the Devil's Advocate, Boris developed Equivalence Classes as an accommodation of his Deletion thinking.

8.1.4.1.2. Other instructional provocations

In this study, Contrasting Prompts, Potentially Pivotal-Bridging Examples, Stimulating Questions and Peer Interpretations (Halani et al., 2013; Roh & Halani, 2011) were also implemented. Once students had determined the validity of an argument presented through Devil's Advocate, the researcher often asked the students to compare their original approach to the problem with the alternative argument presented to them. In this way, the researcher made the students' original argument and the presented argument serve as Contrasting Prompts. The purpose of such a provocation in this study was to help students build connections between the various ways of thinking or recognize the subtle differences between similar ways of thinking.

In addition, the tasks in this study were chosen with the hopes that they would serve as pivotal-bridging examples for the students – thus, they were Potentially Pivotal-Bridging Examples. For example, Task 18: Table appeared to be a Potentially Pivotal-Bridging Example because of the Devil's Advocate. However, there were other occasions where tasks were chosen on-the-fly to create sources of perturbation. Indeed, as discussed in Section 7.2.4.1.1, Al seemed to believe that Equivalence Classes could be used whenever Deletion was appropriate during the eighth session of Phase 2. The researcher asked him to consider Task 2: Dice which involved determining the number of non-double outcomes of a red die and a white die. The hope was that the Dice problem would push Al to reconsider his belief about the relationship between Deletion and Equivalence Classes, making the Dice problem a Potentially Pivotal-Bridging Example. When Al

created the new problem of considering all possible rolls and attempted to engage in Equivalence Classes, he experienced a perturbation. He resolved his perturbation and developed Ratio as an accommodation of Equivalence Classes. Thus, the Dice problem served as a pivotal-bridging example for AI, and the researcher's use of the task was an effective instructional provocation.

Stimulating Questions were also used in this study to push students to recognize inconsistencies in their reasoning. For example, as discussed in Section 7.2.3.1.1, Boris appeared to engage in Deletion thinking for Task 18: Table. Boris experienced a perturbation when the researcher pointed out that he claimed that the size of the complement of the set they were trying to count relied on the size of the set they were trying to count. He appeared to resolve his perturbation and developed Equivalence Classes through the Devil's Advocate described above.

Finally, the researcher implemented *Peer Interpretations* (Halani et al., 2013) during Phase 1 by asking students to reinterpret each other's arguments. The purpose of such a provocation in this study was to help students recognize the similarities and differences between their ways of thinking and also to address student misconceptions. Indeed, when attempting to permute the letters in ARIZONA, Kate engaged in Equivalence Classes while Boris over counted the size of the solution set. Through Peer Interpretations, the students were able to see how Kate's solution dealt with the two A's and thereby recognize the flaw in Boris' solution. See Halani et al. (2013) for a detailed description.

8.1.4.2. Encouraging visual representations

In this study, the researcher used pedagogical content tools (Rasmussen & Marrongelle, 2006), or PCTs, in an effort to encourage students to extend their ways of thinking about combinatorics solution sets. Many of these PCTs involved visual representations and were implemented through Devil's Advocate. For example, for ways of thinking in the Odometer category, the instructor introduced the use of tables and tree diagrams through these Devil's Advocates. There is evidence that some students constructed these representations on their own (see Sections 6.3.1.1 and 6.3.2.1, respectively). However, for other students, a tree diagram presented through Devil's Advocate seemed to be something new and caused some perturbation for the students (see Section 6.3.2.2). The students needed to make sense of the visual image presented and connect it to their previous Standard Odometer thinking. The students' subsequent visualization of tree diagrams while engaging in Standard Odometer indicates that they could coordinate their way of thinking with their visual image. Thus, it seems as if the PCT of tree diagrams helped the students extend their Odometer thinking.

8.1.4.2.1. Venn Diagram Activity

The researcher also encouraged student visualization for Subsets thinking during the second phase of the study. During the retrospective analysis of the first phase, she conjectured that the students' over counting was often a result of not attending to the intersections of non-disjoint subsets when they engaged in Subsets thinking. Venn diagrams seemed to be an appropriate PCT to be used to help students recognize their over counting. For the second phase, she designed the Venn Diagram Activity to be implemented during the fifth session of Phase 2 for Task 14.

This intervention primarily consisted of allowing the student to work with disks cut out of translucent cellophane which could be placed on printed out Venn diagrams. The purpose of this manipulative was to help the student visualize the subsets of elements being considered in both Addition and Union thinking. In this intervention, formal set theoretic language was not used. In a large part, this decision was based on the idea that students have trouble with visualizing and representing set expressions (Bagni, 2006; Hodgson, 1996). Therefore, the student's natural language was to be adopted for use by the instructor. For example, in this study, instead of using the term "intersection," Al chose to refer to the "overlap" in the circles and the researcher used the term as well.

There were two parts to the Venn Diagram Activity. The first, the *Two Set Venn Diagram Activity* was implemented during Task 14(iv), when Al was presented with a sheet of paper with two overlapping circles, a disk cut out of translucent purple cellophane, a disk cut out of translucent yellow cellophane, and a Devil's Advocate driven by Union thinking involving the principle of inclusion-exclusion. Al was asked to reinterpret Ian's argument using the manipulatives. See Section 5.3.1.1 for more information. The *Three Set Venn Diagram Activity* was implemented for Task 14(vi). Here, Al with three translucent cellophane manipulatives of different colors. In this case, a piece of paper with the overlapping circles was not provided with the intention that Al determine the alignment of the circles himself. For this task, Al was presented with two arguments, one at a time. One was driven by Addition thinking, and the other by Union. The second involved the principle of inclusion-exclusion. For both arguments, Al was encouraged to use the manipulatives to represent the presented reasoning and re-interpret the solutions in his own words. See Section 5.3.1.2 for more information.

Al's first solutions to Task 14(iv) and (vi) both involved engaging in Subsets thinking and over counting the size of the solution set. However, it was only after he adjusted his solution to those tasks that the corresponding Venn Diagram Activity was implemented. The purpose of the Venn Diagram Activity was not to address Al's over counting in those particular situations, but to help Al connect his Subsets thinking with the visual representation of Venn diagrams. The hope was that if Al could visualize his Subsets thinking through Venn diagrams, he would be able to avoid over counting in the future.

It seems as if the PCT of Venn diagrams did help Al forge connections between Subsets and the visual representation. Indeed, Al engaged in Union thinking for Task 16 without over counting. He stated that he previously had trouble knowing when the repetition of elements would occur, but now he had a way to look for them. Thus, it appears as if the researcher's encouragement of visualizing Subsets thinking through the PCT of Venn diagrams helped Al avoid over counting.

8.1.5. Limitations of the study

The list of ways of thinking presented in Section 8.1.1 above is by no means exhaustive. It consists of the robust ways of thinking that emerged from the data analysis of this study and its pilot studies. As such, it is limited by the students participating in the studies and in the tasks chosen for the studies. Indeed, just as Ratio thinking emerged from Phase 2 of this study, it is entirely possible that other ways of thinking could emerge as students from a more general population progress through the tasks. In addition, the tasks only involved arrangements with and without repetition, permutations with and without repetition, circle permutations, and combinations without repetition. It is possible

that new ways of thinking could emerge as students progress through tasks with other combinatorial operations such as combinations with repetition.

Further, the students participating in this study and its pilot studies were all undergraduate engineering students in a second-semester Calculus course. They had no formal experience with combinatorics; however, it is likely that the students had been exposed to simple counting problems in their high school curricula or during standardized tests such as the Scholastic Achievement Test (SAT). Therefore, it is possible that students with different mathematical backgrounds without any previous exposure to any counting problems might engage in other ways of thinking.

In addition, the evolution of Problem Posing ways of thinking is described for an epistemic student, not for any particular student in this study. Indeed, none of the students' Problem Posing ways of thinking evolved from Weak Problem Posing to Ratio. However, the data from the study supports the viability of the model – the students in the study were situated alongside the model, as shown in Figure 41, and they made accommodations of their previous ways of thinking in the manner described by the model.

8.2. Implications for the teaching of combinatorics

The implications of this study for the teaching of combinatorics are numerous. First, this study could contribute to helping teachers develop mathematical knowledge for teaching (Silverman & Thompson, 2008) in the domain of combinatorics. Second, this study could assist teachers in implementing instructional interventions designed to help students develop robust ways of thinking about combinatorics. Third, the results of this

study could support curriculum developers in organizing tasks to build upon students' ways of thinking. Each of these implications is discussed in detail with examples below.

8.2.1. Developing mathematical knowledge for teaching combinatorics

Under the philosophical standpoint on learning adopted in this study, the role of a teacher in a classroom is to orient the students' cognitive processes (von Glasersfeld, 1995). In order to teach a topic, a teacher should have developed mathematical knowledge for teaching (MKT) in that particular domain, which entails asking oneself what a student must understand in order to reach the understanding he or she would like the student to reach (Silverman & Thompson, 2008). In other words, the teacher should hypothesize possible learning trajectories which would result in the understanding he or she would like the student to reach. Additionally, a teacher should have the means of recognizing students' current reasoning so that she might guide students to reach a particular understanding. The results of this study have the potential to help teachers develop MKT in the domain of combinatorics.

The framework of ways of thinking emerging from this study is a step towards better understanding students' reasoning as they learn combinatorics. Instructors could use this framework to identify ways of thinking they wish to foster in students. By examining the relationships between various ways of thinking and the model for the evolution of Problem Posing ways of thinking, an instructor might be able to construct hypothetical learning trajectories which could result in the ways of thinking he or she wishes to foster. Further, the framework crystalizes some of the problem solving approaches in which students engage and provides operational characterizations of each of the ways of thinking. The teacher might be able to use these characterizations to

recognize the corresponding ways of thinking in students, and situate the students within the hypothetical learning trajectories.

8.2.2. Implementing instructional interventions

This study has implications for teachers wishing to implement instructional interventions in a combinatorics classroom. These interventions could be used to 1) address potential misconceptions, 2) encourage students to develop robust ways of thinking about combinatorics solution sets, or 3) strengthen students' ways of thinking. This subsection provides examples of how the results of previous research were used in this study to accomplish the first two goals. For the third goal, an example of an intervention involving Venn diagrams could be implemented based on the results of this study.

8.2.2.1. Addressing misconceptions

As discussed in 8.2.1, the ways of thinking identified in this study have the potential to help teachers develop MKT in the domain of combinatorics. Indeed, though a version of Addition and Union (previously called "Partition" by this author) thinking were included in a preliminary framework of ways of thinking after the pilot studies, it was not until the retrospective analysis of Phase 1 that the current characterizations were found. The characterizations in the preliminary framework involved partitioning a solution set into disjoint sets. In this study, it was through a revision of the characterizations of both Subsets ways of thinking to include the possibility of viewing the solution set as the union of non-disjoint sets that the relationship between Subsets thinking and the error of over counting became clearer. Indeed, over counting tends to

occur when students envision the solution set as the union of non-disjoint subsets but are not attending to the non-empty intersections.

In an effort to help students visualize their Subsets thinking and avoid over counting, the researcher created the Venn Diagram Activity. As discussed in Section 8.1.4.2.1, Al indicated that this activity helped him see how the repetition of elements between subsets could occur. Thus, by better understanding Subsets thinking, the researcher was significantly more able to address the over counting associated with that category.

Other combinatorics teachers might be able to implement the Venn Diagram Activity in their own classes. Further, by better understanding student reasoning through the results of this study, these teachers might be able to design and implement other instructional interventions to address student misconceptions.

8.2.2.2. Fostering robust ways of thinking

The results of this study also have the potential for helping teachers design and implement instructional interventions with the purpose of fostering robust ways of thinking in the students. Indeed, it was through an examination of Sara's creation of a table for Task 18: Table in a pilot study that the idea for the Devil's Advocate driven by Equivalence Classes and attributed to Pat emerged. This intervention appeared to introduce the students to Equivalence Classes and the students developed Equivalence Classes as an accommodation of Deletion as a result of this intervention. By gaining more understanding as to how a student could construct Equivalence Classes, the researcher was better able to design an intervention to foster such a way of thinking in the

students in this study. Thus, it is possible that other teachers might be able to use their understanding of student's ways of thinking about combinatorics solution sets from this study to design other instructional provocations to foster robust ways of thinking in students. For example, a teacher wishing to foster Ratio thinking could design a Devil's Advocate for Task 2: Dice based on Al's reasoning about the task.

8.2.2.3. Strengthening ways of thinking

This study also has the potential for assisting teachers in designing and implementing instructional interventions to help students strengthen their ways of thinking and build connections between them. In this study, the introduction of Venn diagrams and tree diagrams served to help students strengthen their Subsets and Odometer ways of thinking, respectively. From an actor-oriented perspective (Lobato & Siebert, 2002), Al transferred the use of Venn diagrams from Subsets thinking to Problem Posing, and, following the introduction of the universal set, within the Problem Posing category from Deletion to Equivalence Classes. It is likely that he transferred this visual representation from one way of thinking to another because he could see the connections between them. A teacher wishing to foster such connections could design instructional interventions based on Al's reasoning. For example, a teacher could introduce a Venn diagram with a universal set for Carrie's Deletion argument for Task 14, and a Venn diagram with a universal set for an Equivalence Classes argument later in the instructional sequence. Thus, the teacher could encourage students to first build connections between the categories of Subsets and Problem Posing, and then within the Problem Posing category from Deletion to Equivalence Classes.

In addition, by using the relationships between ways of thinking identified in this study, a teacher could facilitate student discussion about the similarities and differences between various ways of thinking. For example, the teacher could push students to address the similarities and differences between Standard and Wacky Odometer. Such a discussion could help students engage in reflective abstraction and build connections between various ways of thinking.

8.2.3. Designing combinatorics curricula

This study also has the potential of assisting curriculum developers in the sequencing of tasks to build upon students' ways of thinking about combinatorics solution sets. As Maher et al. (2010) note, careful task design is essential for helping students develop ways of reasoning, such as cases, contradiction, recursion, and induction. It seems likely that such careful design is also important for assisting students to develop ways of thinking, and the results of this study could aid curriculum designers in this effort. For example, by understanding the relationships between the various ways of thinking, curriculum developers could organize tasks to foster connections between ways of thinking and encourage the development of new ways of thinking. Indeed, curriculum developers could use the model of the evolution of students' Problem Posing ways of thinking to organize tasks to build upon students' ways of thinking. Further, the model describes the perturbation students experience and the limitations of each way of thinking. Curriculum developers could design tasks with the intention of causing perturbation by pushing students to realize these limitations. By understanding how students make accommodations, curriculum developers could design interventions to help students resolve their perturbation.

Finally, a consequence of this study's design is an instructional sequence which attempts to foster Equivalence Classes and Generalized Odometer. In fact, all of the students in the study made accommodations of their current thinking to develop these ways of thinking as conjectured. The tasks, their intention in the study, their implementation in the study, and alternative arguments are all described in Appendix A. An instructor wishing to teach combinatorics could adapt this sequence for the classroom.

8.3. Further Discussion

This Section first discusses how the results of this study connect to the existing literature and then discusses possible avenues for future studies.

8.3.1. Relation to the existing literature

This study contributes to the existing body of research on ways of thinking (Harel, 2008; Harel & Sowder, 2005), heuristics (Polya, 1957; Schoenfeld, 1992), and strategies (Bjorklund, 1990; English, 1991, 1993). Further, it expands the model of students' combinatorial thinking put forth by Lockwood (2011a), and suggests an extension to the existing literature on actor-oriented transfer in combinatorics (Lockwood, 2011b).

8.3.1.1. Ways of thinking, heuristics, and strategies

According to Harel (2008), *ways of thinking* are cognitive characteristics of mental acts. For the problem solving mental act, ways of thinking are problem solving approaches which students might implement to solve given tasks. This study builds upon Harel's work by investigating students' ways of thinking in the domain of combinatorics.

Some examples of ways of thinking, or problem solving approaches, are *heuristics* (Polya, 1957; Schoenfeld, 1992) or "rules of thumb for effective problem

solving” (Schoenfeld, 1985, p. 23). However, the same heuristic can give rise to different ways of thinking depending on the mathematical domain (Schoenfeld, 1992). This study connects students’ ways of thinking about combinatorics solution sets to two common heuristics.

The first heuristic involves decomposing a task into cases. In a study encouraging students’ use of heuristics, it was stated “Try to establish subgoals. Can you obtain part of the answer, and perhaps go on from there? Can you decompose the problem so that a number of easier results can be combined to give the total result you want?” (Schoenfeld, 1985, p. 195). Schoenfeld found that even when explicitly suggested to decompose problems into cases, students had trouble knowing how to do so. In this study, the Subsets category was identified as containing two ways of thinking related to the heuristic of decomposing problems into cases. Indeed, both ways of thinking in the Subsets category involve grouping elements in the solution set into subsets based on certain criteria. The criteria could be found by decomposing the problem into cases which each correspond to a criterion. This study extends Schoenfeld’s (1985) work on cases, by showing that even if a student can decompose a problem into cases, he or she still might not be able to find a solution to the task at hand. See Section 5.2.1.

Another heuristic commonly suggested to students is to exploit a related problem by modifying one of the criteria in the given problem (Polya, 1957). Sometimes, the related problem could be one the students have already solved. Silver (1979, 1981) investigated student perceptions of problem relatedness and found that even when students knew they should remember a related problem, they could not always do so. Further, English (1999) found that when combinatorics students attempted to pose new

problems by modifying a criterion in a given problem, they sometimes posed unsolvable problems. The Problem Posing category was identified in this study as being related to the heuristic of posing and exploiting a related problem. When engaging in the ways of thinking belonging to this category, students spontaneously posed problems by modifying a criterion in the given task. Though not all of the ways of thinking in this category were natural for the students, the common characteristic of problem posing was natural for all of the students in this study and in the pilot studies. In fact, none of the students in this study ever posed unsolvable problems. Thus, this study extends research conducted on the heuristic of problem posing by connecting ways of thinking about combinatorics with the heuristic and showing that students may naturally pose solvable problems.

Finally, this study extends the work done by English (1991, 1993) on the odometer strategy by identifying related ways of thinking. Students engaging in the odometer strategy would hold an item constant while systematically varying other items in an effort to generate all elements of the solution set. The students engaging in this strategy would presumably be able to answer the question of how many elements were in a particular solution set by physically counting the elements in their solution set. From English's results, it seems as if the odometer strategy is truly a *strategy*, or a goal-directed mental operation to facilitate the completion of the task (Bjorklund, 1990). Thus, a student implementing the strategy might not be able to anticipate the results of the strategy or reason about the relationships between elements of the solution set. In other words, the odometer strategy is not a way of thinking. Odometer thinking was identified in this study as ways of thinking which extend English's odometer strategy. Students engaging in Odometer thinking would mentally hold items constant and vary others, but

they would be able to anticipate the result of doing so and find relationships between the elements of the solution set.

8.3.1.2. Model of combinatorial thinking

Lockwood (2011a) presented a model of students' combinatorial thinking which included the following components: sets of outcomes, counting processes, formulas/expressions. She described how students coordinate sets of outcomes with counting processes and vice versa, and how students coordinate counting processes with expressions and vice versa. She conjectured that students could also coordinate sets of outcomes with expressions and vice versa. Based on the results of this study, it appears as if a component could be added to her model: visual representations.

As Fischbein (1977) stated, students' coordination of conceptual structures with visual images is essential for problem solving. This study found that some visual representations came naturally to students. The researcher encouraged students' visualization by using PCTs to introduce students to ways to visually represent their existing ways of thinking. Regardless of whether students spontaneously used visual images to express their ways of thinking or were introduced to such representations through instruction, it appears as if the students in this study could coordinate their sets of outcomes with their visual representations. Indeed, the representations corresponded to specific ways of thinking about solution sets and often actually included elements of the solution set (e.g tree diagrams, tables, mapping diagrams). In the cases where elements were not explicitly included in a representation (such as Venn diagrams), the student would refer to the sets of elements that each portion of the diagram represented.

The coordination of solution sets with visual representations can go both directions. Indeed, Kate and Boris were presented with just a visual image (tree diagram) through Devil's Advocate for Task 11 and they were able to connect the representation to Boris' previous way of thinking (Standard Odometer) about the elements of the solution set. In the other direction, Al engaged in Union thinking for Task 16(iii) to reason about the elements of the solution set. When pressed to explain his solution, Al drew a Venn diagram. Thus, students can coordinate solution sets with visual representations and vice versa.

This study was designed to examine students' ways of thinking about solution sets. As a result, there are not many data that are not related to elements of the solution set. However, one can conjecture the coordination of visual representations with the other components in Lockwood's (2011a) model. First, it could be that one could coordinate visual representations with expressions. Indeed, when presented with the structure of a tree diagram, consisting of four roots with three branches, one could associate that with the expression 4×3 because there are three leaves per tree and a total of four trees. Similarly, the expression 4×3 could evoke the visual image of a tree diagram consisting of four roots with three branches. Second, visual representations could be coordinated directly with a counting process. Indeed, the process of choosing one of four items and then one of three could evoke the representation of a tree diagram consisting of four roots (for the first stage of the process) with three branches (for the second stage in the process). Similarly, when presented with the structure of a tree diagram, consisting of four roots with three branches, one could associate it with the process of choosing one of four items, and then choosing one of three. In all of the examples above, the tree diagram

consists only of a structure – nothing is filled in at the vertices of the trees and so the visual image does not include elements of the solution set. This means that each of these coordinations could happen independently of a set of outcomes.

The discussion above showed that students coordinate visual representations with sets of outcomes and vice versa. In addition, it conjectured that one could coordinate the representations with counting processes or expressions and vice versa. Thus, it appears as if Lockwood's (2011a) model could be expanded to include the additional component of visual representations.

8.3.1.3. Actor-oriented transfer

This study extends research done on actor-oriented transfer (Lobato & Siebert, 2002; Lockwood, 2011b), or AOT. Lockwood (2011b) categorized the AOT she observed in combinatorics by students' referents: particular problem, problem type, and technique/strategy. This study extends Lockwood's categories by identifying another possible referent: visual representation. From an actor-oriented perspective, Al transferred "factor trees" from prime factorization to the domain of combinatorics. In addition, he transferred the use of Venn diagrams from Subsets thinking to Deletion (see Section 7.3.1.1), and the use of a universal set from Deletion to Equivalence Classes (see Section 7.3.2.2).

By adopting the lens of AOT, one can see the connections that Al made between different ways of thinking. For instance, when after working with Carrie's argument which was driven by Deletion thinking, Al stated that it was kind of like the Venn diagram. His representation for Deletion was a Venn diagram which had superfluous

aspects. The portions of the Venn diagram he used showed that he represented the whole new solution set as a circle and the original solution set as a subset of the circle. It is clear that Al made a connection between Subsets and Deletion since Venn diagrams had only been used for Subsets thinking at that point of the study. It is possible that the reason he viewed the Subsets thinking and Deletion as similar is because they both involve subsets.

8.3.2. Future research

There are several possible avenues for new studies building upon the results of this study. First, this study's participants were undergraduate students and it is likely that the students participating in this study had some exposure to counting problems in their pasts. According to Piaget and Inhelder (1975), students should be able to reason combinatorially by the time they reach the formal operational stage of development. Thus, one avenue for future research is to extend the ages of the students participating in the study. Because counting problems might be completely novel to younger students, the development of their ways of thinking could be different. This could facilitate a closer inspection of the evolution of ways of thinking in other categories such as Odometer. In addition, the study could be extended by including more tasks and combinatorial operations. Indeed, it seems likely that students would engage in other ways of thinking for other operations such as combinations with repetition. Second, the framework for ways of thinking could be used to investigate how these ways of thinking are distributed between various mathematical populations both with and without instruction. Third, combinatorial proof requires students to pose a problem whose solution set can be counted in two different ways (Bogart, 2000; Tucker, 2002). The framework developed through this research could be used to identify the different ways students solve the

newly-posed problem. In addition, by exploring the ways of thinking in which students engage to solve the newly-posed problem, one could further understand the relationships students see between the different ways of thinking identified through this study.

REFERENCES

- Abromovich, S., & Pieper, A. (1996). Fostering recursive thinking in combinatorics through the use of manipulatives and computing technology. *The Mathematics Educator*, 7(1), 4-12.
- Alcock, L., & Simpson, A. (2004). Convergence of sequences and series: Interactions between visual reasoning and the learner's beliefs about their own role. *Educational Studies in Mathematics*, 57(1), 1-32.
- Bagni, G. (2006). Some Cognitive Difficulties Related to the Representations of Two Major Concepts of Set Theory. *Educational Studies in Mathematics*, 62(3), 259-280.
- Batanero, C., Godino, J. D., & Navarro-Pelayo, V. (1997a). Combinatorial Reasoning and its Assessment. In I. Gal & J. B. Garfield (Eds.), *The Assessment Challenge in Statistics Education* (pp. 239-252). Amsterdam: IOS Press.
- Batanero, C., Godino, J. D., & Navarro-Pelayo, V. (1997b). Effect of the implicit combinatorial model on combinatorial reasoning in secondary school pupils. *Educational Studies in Mathematics*, 32(2), 181-199.
- Bjorklund, D. F. (1990). *Children's strategies: Contemporary views of cognitive development*: Psychology Press.
- Black, M. (1977). More about metaphor. *Dialectica*, 31, 433-457.
- Bogart, K. (2000). *Introductory Combinatorics* (3 ed.). San Diego, CA: Harcourt Academic Press.
- Cadwalladerolsker, T., Annin, S., & Engelke, N. (2011). Counting problem strategies of preservice secondary teachers. *Proceedings of the 14th Annual Conference on Research in Undergraduate Mathematics Education*, 4, 37-41.
- Carlson, M., Jacobs, S., Coe, E., Larsen, S., & Hsu, E. (2002). Applying covariational reasoning while modeling dynamic events: A framework and a study. *Journal for Research in Mathematics Education*, 33(5), 352-378.
- Clement, J. (2000). Analysis of clinical interviews: Foundations and model viability. In R. Lesh & A. Kelly (Eds.), *Handbook of research methodologies for science and mathematics education* (pp. 341-385). Hillsdale, NJ: Lawrence Erlbaum.
- Cobb, P. (2007). Putting philosophy to work: Coping with multiple theoretical perspectives. In F. Lester (Ed.), *Second handbook of research on mathematics teaching and learning* (Vol. 1, pp. 3-38). Greenwich, TV: Information Age Publishing.
- Dubois, J. G. (1984). Une systematique des configurations combinatoires simples. *Educational Studies in Mathematics*, 15(1), 37-57.

- Eizenberg, M. M., & Zaslavsky, O. (2004). Students' verification strategies for combinatorial problems. *Mathematical Thinking and Learning*, 6(1), 15-36.
- English, L. (1991). Young children's combinatorics strategies. *Educational Studies in Mathematics*, 22(5), 451-474.
- English, L. (1993). Childrens' strategies for solving two- and three- dimensional combinatorial problems. *Journal for Research in Mathematics Education* 24(3), 255-273.
- English, L. (1999). Assessing for structural understanding in childrens' combinatorial problem solving. *Focus on Learning Problems in Mathematics*, 21(4), 63-83.
- English, L. (2005). Combinatorics and the Development of Children's Combinatorial Reasoning. In G. A. Jones (Ed.), *Exploring Probability in school: Challenges for teaching and learning* (pp. 121-141).
- Fischbein, E. (1977). Image and Concept in Learning Mathematics. *Educational Studies in Mathematics*, 8(2), 153-165.
- Fischbein, E., & Gazit, A. (1988). The Combinatorial Solving Capacity in Children and Adolescents. *Zentralblatt fur Didaktik der Mathematik* 5, 193-198.
- Fischbein, E., & Grossman, A. (1997). Schemata and intuitions in combinatorial reasoning. *Educational Studies in Mathematics*, 34(1), 27-47.
- Fischbein, E., & Schnarch, D. (1997). The evolution with age of probabilistic, intuitively based misconceptions. *Journal for Research in Mathematics Education*, 28(1), 96-105.
- Freudenthal, H. (1973). *Mathematics as an educational task*. Dordrecht, Netherlands: Reidel.
- Gick, M. L. (1986). Problem-solving strategies. *Educational psychologist*, 21(1-2), 99-120.
- Godino, J. D., Batanero, C., & Roa, R. (2005). An onto-semiotic analysis of combinatorial problems and the solving processes by university students. *Educational Studies in Mathematics*, 60(1), 3-36.
- Gruber, H. E., & Voneche, J. J. (Eds.). (1977). *Essential Piaget*. New York: Basic Books, Inc.
- Hadar, N., & Hadass, R. (1981). The road to solving a combinatorial problem is strewn with pitfalls. *Educational Studies in Mathematics*, 12, 435-443.
- Halani, A. (2012a). Students' ways of thinking about combinatorics solution sets: Deletion and Equivalence Classes. *Proceedings of the 34th Annual Conference of the North American Chapter of the International Group for the Psychology of Mathematics Education*, 206-210.

- Halani, A. (2012b). Students' ways of thinking about enumerative combinatorics solution sets: The odometer category. *Proceedings of the 15th Annual Conference on Research in Undergraduate Mathematics Education*, 1, 231-245.
- Halani, A., Davis, O., & Roh, K. (2013). Critiquing the Reasoning of Others: Devil's Advocate and Peer Interpretations as Instructional Interventions. *Proceedings of the 16th Annual Conference on Research in Undergraduate Mathematics Education*. Retrieved from http://pzacad.pitzer.edu/~dbachman/RUME_XVI_Linked_Schedule/rume16_submission_114.pdf website:
- Harel, G. (2008). What is mathematics? A pedagogical answer to a philosophical question. In R. B. Gold & R. Simons (Eds.), *Proof and Other Dilemmas: Mathematics and Philosophy*: Mathematical American Association.
- Harel, G., & Sowder, L. (2005). Advanced mathematical-thinking at any age: Its nature and its development. *Mathematical Thinking and Learning*, 7(1), 27-50.
- Heinze, A., Anderson, I., & Reiss, K. (2004). Discrete mathematics and proof in the high school. *ZDM*, 36(2), 44-45.
- Hodgson, T. (1996). Students' Ability to Visualize Set Expressions: An Initial Investigation. *Educational Studies in Mathematics*, 30(4), 159-178.
- Kapur, J. N. (1970). Combinatorial analysis and school mathematics. *Educational Studies in Mathematics*, 3(1), 111-127.
- Kavousian, S. (2008). *Enquiries into undergraduate students' understanding of combinatorial structures*. (Unpublished doctoral dissertation), Simon Fraser University, Vancouver, BC.
- Lobato, J., & Siebert, D. (2002). Quantitative reasoning in a reconceived view of transfer. *Journal of Mathematical Behavior*, 21, 87-116.
- Lockwood, E. (2010). An investigation of Post-Secondary Students' Understanding of Two Fundamental Counting Principles. *Proceedings of the 13th Annual Conference on Research in Undergraduate Mathematics Education*.
- Lockwood, E. (2011a). *Student approaches to combinatorial enumeration: The role of set-oriented thinking*. (Unpublished Doctoral Dissertation), Portland State University, Portland, OR.
- Lockwood, E. (2011b). Student connections among counting problems: an exploration using actor-oriented transfer. *Educational Studies in Mathematics*, 78(3), 307-322.
- Maher, C. A., Powell, A. B., & Uptegrove, E. B. (2010). *Combinatorics and reasoning: Representing, justifying and building isomorphisms* Vol. 47.

- Mason, J. H. (2002). *Mathematics teaching practice: Guide for university and college lecturers*: Horwood Pub Limited.
- Nunokawa, K. (2001). Interactions between subgoals and understanding of problem situations in mathematical problem solving. *The Journal of Mathematical Behavior*, 20(2), 187-205.
- Oehrtman, M. C. (2002). *Collapsing dimensions, physical limitation, and other student metaphors for limit concepts: An instrumentalist investigation into calculus students' spontaneous reasoning*. (Unpublished doctoral dissertation), The University of Texas, Austin, TX.
- Palais, R. S. (1999). The visualization of mathematics: Towards a mathematical exploratorium. *Notices of the AMS*, 46(6), 647-658.
- Piaget, J. (1980). *Adaption and intelligence: Organic selection and phenocopy*. Chicago, IL: The University of Chicago Press.
- Piaget, J. (1985). *The equilibration of cognitive structures: The central problem of intellectual development*. Chicago, IL: The University of Chicago Press.
- Piaget, J., & Inhelder, B. (1975). *The origin of the idea of chance in children*. New York: W.W. Norton.
- Pinto, M., & Tall, D. (2002). Building formal mathematics on visual imagery: A case study and a theory. *For the learning of mathematics*, 22(1), 2-10.
- Polya, G. (1957). *How to solve it: A new aspect of mathematical method*: Princeton University Press.
- Presmeg, N. C. (2006). Research on visualization in learning and teaching mathematics. *Handbook of research on the psychology of mathematics education*, 205-235.
- Pritchard, D. (2010). Where learning starts? A framework for thinking about lectures in university mathematics. *International Journal of Mathematical Education in Science and Technology*, 41(5), 609-623.
- Rasmussen, C., & Marrongelle, K. (2006). Pedagogical Content Tools: Integrating Student Reasoning and Mathematics in Instruction. *Journal for Research in Mathematics Education*, 37(5), 388-420.
- Rasmussen, C., Kwon, O., & Marrongelle, K. (2008). A framework for interpreting inquiry-oriented teaching. *Proceedings of the 11th Annual Conference on Research in Undergraduate Mathematics Education*.
- Roh, K. (2008). Students' images and their understanding of definitions of the limit of a sequence. *Educational Studies in Mathematics*, 69(3), 217-233.

- Roh, K. (2010). An empirical study of students' understanding of a logical structure in the definition of limit via the ϵ -strip activity. *Educational Studies in Mathematics*, 73(3), 263-279.
- Roh, K., & Halani, A. (2011). *Instructional Provocations for Inquiry-based Learning in College Mathematics*. Unpublished manuscript. School of Mathematical and Statistical Sciences. Arizona State University.
- Schoenfeld, A. H. (1979). Explicit heuristic training as a variable in problem-solving performance. *Journal for Research in Mathematics Education*, 173-187.
- Schoenfeld, A. H. (1980). Teaching problem-solving skills. *The American Mathematical Monthly*, 87(10), 794-805.
- Schoenfeld, A. H. (1985). *Mathematical problem solving*. Orlando, FL: Academic Press.
- Schoenfeld, A. H. (1992). Learning to think mathematically: Problem solving, metacognition, and sense making in mathematics. *Handbook of research on mathematics teaching and learning*, 334-370.
- Shin, J., & Steffe, L. P. (2009). *Seventh-graders' use of additive and multiplicative reasoning for enumerative combinatorics problems*. Paper presented at the 31st Annual meeting of the North American Chapter of the International Group for the Psychology of Mathematics Education, Atlanta, GA: Georgia State University.
- Silver, E. A. (1979). Student perceptions of relatedness among mathematical verbal problems. *Journal for Research in Mathematics Education*, 10(3), 195-210.
- Silver, E. A. (1981). Recall of mathematical problem information: Solving related problems. *Journal for Research in Mathematics Education*, 12(1), 54-64.
- Silverman, J., & Thompson, P. W. (2008). Toward a framework for the development of mathematical knowledge for teaching. *Journal of Mathematics Teacher Education*, 11, 499-511.
- Steffe, L. P. (1992). Schemes of action and operation involving composite units. *Learning and Individual Differences*, 4(3), 259-309.
- Steffe, L. P., & Thompson, P. W. (2000). Teaching experiment methodology: Underlying principles and essential elements. In R. Lesh & A. E. Kelly (Eds.), *Research design in mathematics and science education* (pp. 267-307). Hillsdale, NJ: Erlbaum.
- Strauss, A., & Corbin, J. (1998). *Basics of qualitative research: Techniques and procedures for developing grounded theory* (Second ed.). Thousand Oaks, CA: Sage Publications.
- Tall, D. (1991). Intuition and rigour: the role of visualization in the calculus. In W. Zimmermann & D. Cunningham (Eds.), *Visualization in Mathematics* (Vol. 19, pp. 105-119). Washington, D.C.: Mathematical Association of America Notes.

- Thompson, A. G., & Thompson, P. W. (1994a). Talking about Rates Conceptually, Part II: Mathematical Knowledge for Teaching. *Journal for Research in Mathematics Education*, 27(1), 2-24.
- Thompson, P. W. (1994a). The development of the concept of speed and its relationship to concepts of rate. In G. Harel & J. Confrey (Eds.), *The development of multiplicative reasoning in the learning of mathematics* (pp. 181-234). Albany, NY: SUNY Press.
- Thompson, P. W. (1994b). Images of rate and operational understanding of the Fundamental Theorem of Calculus. *Educational Studies in Mathematics*, 26(2-3), 229-274.
- Thompson, P. W. (in press). Constructivism in Mathematics Education. In Springer (Ed.), *Encyclopedia of Mathematics Education*.
- Thompson, P. W., & Saldanha, L. (2000). *Epistemological analyses of mathematical ideas: A research methodology*. Paper presented at the Proceedings of the Twenty Second Annual Meeting of the North American Chapter of the International Group for the Psychology of Mathematics Education, ERIC Clearinghouse for Science, Mathematics, and Environmental Education, Columbus, OH, Tucson, AZ.
- Thompson, P. W., & Saldanha, L. (2003). Fractions and Multiplicative Reasoning. In J. Kilpatrick, G. Martin & D. Schifter (Eds.), *Research companion to the Principles and Standards for School Mathematics* (pp. 95-114). Reston, VA: National Council of Teachers of Mathematics.
- Thompson, P. W., & Thompson, A. G. (1994b). Talking about Rates Conceptually, Part I: A Teacher's Struggle. *Journal for Research in Mathematics Education*, 25(3), 279-303.
- Tucker, A. (2002). *Applied Combinatorics* (4 ed.). New York, NY: John Wiley & Sons.
- Von Glasersfeld, E. (1995). *Radical Constructivism: A Way of Knowing and Learning*. Washington, D.C.: Falmer Press.
- Wadsworth, B. J. (1996). *Piaget's Theory of Cognitive and Affective Development: Foundations of Constructivism* (5th ed.). New York City: Longman.
- Zazkis, R., & Chernoff, E. J. (2008). What makes a counterexample exemplary. *Educational Studies in Mathematics*, 68, 195-208.

APPENDIX A

TASKS AND PROTOCOLS DESIGNED FOR PHASE 2

This appendix consists of the tasks and protocols to be implemented in the sessions of the teaching experiment. This Section first describes the general protocol to be implemented for each task. Following this general protocol, the tasks are separated by session, and an overview of each session is provided before discussion of the actual tasks. In this overview, the framing of the session, or the general purpose of the session and ways of thinking likely to be discovered or encouraged, is discussed. Then, for each task, the situation and question, the framing of the task in the context of the study, the administration protocol for that particular task, and the Alternative Argument(s)/Solution(s) students will analyze are provided.

A few tasks will be conducted in a clinical interview style instead of a teaching experiment style. The following general protocol describes the administration protocol for tasks 2-15 and 17-30. The administration protocol for Task 1 (Mississippi I), Task 16 (Sororities) and Task 31 (Mississippi II) is discussed in the “Administration Protocol” Section of those tasks.

General Protocol:

The researcher will ask the student to explain how he thought about the problem at the end of each task. In general, the researcher will begin the task by presenting the students with the situation and asking them “Okay, why don’t you think for about 30 seconds about the situation, and then, in turns, share what you envision?” Then, the students will share what they envision as they think about the situation (in an All-Purpose-Go-Around for paired sessions). The researcher will ask some clarifying questions about their assumptions. Then she will present them with the question (one at a

time if there are multiple ones). The students will be given time to think about the questions individually and then share their ideas with each other in an APGA (the order of the APGA will alternate in each task). The researcher will ask clarifying questions (such as “How can you tell?” “Why do you think so?”, “Can you explain why?”, etc.) as necessary. She will only intervene if students are stuck or once they have solved the problem. Her interventions if they are stuck will depend on the task/situation, and she will use Stimulating Questions to help the students find their error or conflicting assumptions, and proceed through the task. The researcher will ask the student to explain how he thought about the problem at the end of each task. Once they have solved the problem, she will discuss their assumptions in the task. If they had assumptions which do not coincide with the mathematical community’s assumptions, she will elaborate on this fact and ask them to work through the problem again. For example, if the students believe that objects with different colors are identical and solve the problem under this assumption, the researcher will ask the students to describe their assumptions for the task. She will then explain that in the mathematical community, objects with different colors are assumed to be distinct from one another. As an example, she will say that a blue car is considered different from a black car and that a red die is considered different from a white die. The students will then work through the problem again with these new assumptions about the situation.

These tasks are designed with a particular hypothetical learning trajectory in mind, as discussed in the Methodology chapter. The tasks were chosen to push the students to develop or extend certain ways of thinking which will build upon each other. As such, after the students solve each task, the researcher will often implement

instructional interventions such as Contrasting Prompts or Devil's Advocate in order to push them to further develop their reasoning and deepen/extend their ways of thinking. In addition, (Batanero et al.) (1997b) claimed that the Implicit Combinatorial Model (ICM) had an effect on students' ability to solve a combinatorial problem. As discussed in the Methodology chapter, many tasks in this study were chosen because they involve the same combinatorial operations as other problems but different ICM. Students will have an opportunity to deepen their ways of thinking by applying them in different types of situations. Furthermore, the researcher might observe whether students engage in different ways of thinking when presented with tasks involving different ICM.

Following the first interview, each day will start out with a review of the ways of thinking uncovered in the previous session. For example, in Paired Session 1, the researcher will ask the students "Can you describe how you were thinking about the tasks in the previous session? In particular, can you talk about the way of thinking you used for the Security Codes task? Was it any different from how you were thinking about the previous ones?" Once the students give their feedback, the researcher will rephrase the students' ways of thinking by saying something like "Okay, so in general, you had this idea of holding one thing constant and then cycling through the others to get everything." As another example, in Paired Session 3, the researcher will review permutations and factorial notation. She will ask the students to describe how they were thinking about the tasks in the previous session. The students will likely briefly discuss creating a new problem. The researcher will rephrase the students' ways of thinking about the idea of creating a new problem whose solution set can be grouped into parts of equal size where each part corresponds to an element of the original solution set by saying something like

”In the Table problem, one idea we used was to create a new problem of unclasping the circle and finding the number of ways to permute the people. Then, we grouped the permutations based on which table setting they correspond to. We found a way to relate the size of the new solution set to the size of the original solution set by considering the number of elements in each group.”

Each session will end with a closing where the students share their impressions of the session. The students will also discuss these impressions in their reflections.

Individual Interview 1:

These tasks are designed so that the researcher can get a sense of the students’ initial ways of thinking about combinatorics and have them develop the Odometer way of thinking. It is known that social interaction can serve as a catalyst for students to construct knowledge (Cobb, 2007). So that the researcher can attend to how these initial ways of thinking develop slowly in the individual student, these tasks are implemented in individual interviews. Tasks 2-5 all involve 2-item arrangements. In addition, the students will ideally develop the Standard Odometer way of thinking in this interview.

(1) Mississippi I

- Task:
 - Situation: Imagine that the state of Mississippi is adopting new, 11-character license plates. For fun, the state agreed to provide citizens who use the letters in the word “MISSISSIPPI” arranged in any order with a special license plate with an image of the mockingbird (the Mississippi state bird) as the background.
 - Question: How many of these special license plates with the mockingbird must the state be prepared create?
- Framing:
 - This task is designed to assess students’ initial ways of thinking about permutations with repeated elements. In particular, this task is one of the most difficult the students will encounter in this study, and the students will

encounter a version of this problem later in the study. As a result, it serves as a pre-test of sorts. In addition, it allows the researcher to introduce the concept of combinatorics in a real-world situation.

- It is not anticipated that the student will be able to solve this task. However, the researcher will attend to whether the student considers holding a letter constant and attempts to cycle through the other letters, whether he attempts to create a new problem whose solution set size is additively or multiplicatively related to the size of the solution set of the original problem, etc.
- Administration Protocol:
 - The researcher will provide the task to the student and ask him to speak aloud as he reasons through the task. The researcher will implement a clinical interview type protocol for this task, meaning she will only ask questions to clarify the student's statements. She will repeat the student's statements, but will make an effort not to rephrase them. Questions she might ask include "what is the question asking?", "what do you mean by that?", "How can you tell?", "Why do you think so?" and so forth.
 - In order to get more information from the students, the researcher might ask if the students have ever encountered a problem of this sort before. If they have, she will ask them about their past experience with a problem like this and how they solved it in the past. If they have trouble, she might ask if they've seen any similar problems and if they could show her how they approached those. Finally, she might ask them to outline a strategy for solving this problem even if they cannot actually follow the strategy through (this will hopefully give information about their ways of thinking and how they envision the solution set).

(2) Dice

- Task:
 - Situation: Two dice are rolled, one white and one red.
 - Question: How many outcomes are there that are not doubles?
- Framing:
 - This is the first 2-item arrangement problem the students will encounter. This task was chosen as the first task to be implemented in a teaching experiment style because the size of the solution set is fairly small and students could use numerous ways to determine this size. The researcher will pay particular attention to whether the student seems to search for a systematic way to list the elements of the solution set. Furthermore, the researcher will attend to whether the students employ deletion in the middle, at the end, or if the students do not use deletion at all.
- Administration Protocol:
 - The researcher will provide the students with two dice, one white and one red, and ask what an "outcome" would look like. The student will likely roll the dice and point to it. The researcher will ask if a 1 on the red with a 2 on the white is the same thing as a 2 on the red and a 1 on the white. The researcher will accept his response, regardless of what it is. She will ask them how we can keep record and track of the outcomes, and perhaps suggest that they write down a few outcomes.

- Then, the researcher will provide the student with the actual question and let the students work. She will not interfere at all with the way they answer the question, except to ask clarifying questions. *If* it comes up that ways to get a white 1 are mostly in a specific row or column and the students seems disturbed by this, she may suggest that the students re-organize their list/table so that all of the white 1s are in the same row.
- If the students do hold one object constant and employ the odometer strategy in order to get an answer of 30, the researcher will employ Devil's Advocate by providing Carmen's argument: first we hold the red constant and get this list, but now we need to do the same thing with the white ... so we get another 30 and all together we get 60. The student will be asked to analyze the argument.
 - Note: If the students do not employ the odometer strategy, Devil's Advocate will be employed in another problem.
- As mentioned in the General Protocol Section above, if the student has assumed that the 1 on the red with a 2 on the white is the same thing as a 2 on the red and a 1 on the white, the researcher will discuss these assumption with the student and explain how the mathematical community in general would interpret the situation. Then, she will ask the student to repeat the problem with these new assumptions.

- Alternative Argument(s)/Solution(s):

- Carmen's: There are two ways to consider the two dies: (1) the red one first and then the white one; or (2) the white one and then the red one.
- When considering the red one first, we hold the red constant and get this list:

Red: 1 – 2, 3, 4, 5, 6
 2 – 1, 3, 4, 5, 6
 3 – 1, 2, 4, 5, 6
 4 – 1, 2, 3, 5, 6
 5 – 1, 2, 3, 4, 6
 6 – 1, 2, 3, 4, 5

Now we need to do the same thing with the white to be considered first:

White: 1 – 2, 3, 4, 5, 6
 2 – 1, 3, 4, 5, 6
 3 – 1, 2, 4, 5, 6
 4 – 1, 2, 3, 5, 6
 5 – 1, 2, 3, 4, 6
 6 – 1, 2, 3, 4, 5

We add all of these together to get the total amount.

(3) Committee 1

- Task:
 - Situation: A club has 6 members and wishes to choose a president and vice president from among the members. The same person cannot hold both positions.
 - Question: In how many ways can the club choose these officers?
- Framing:

- Mathematically, there is a bijective correspondence between the solution set of this problem and that of the previous problem: 2) Dice. The context is different, however. There is research that indicates that students reason differently about problems involving numbers and problems involving people (Fischbein & Gazit, 1988), though other research indicates that there is no difference (Batanero et al., 1997b). It will be interesting from a research standpoint to observe whether students do reason differently about this problem. In addition, because of the similarity of the problem to the previous, students might refine their ways of thinking for efficiency. However, there are slight differences between this problem and the previous one – for example, it is possible to roll doubles, but it is impossible to elect the same person to both positions. As a result, it is possible that while students might engage in the Deletion way of thinking in the previous problem, they might not in this problem.
- Administration Protocol:
 - The researcher will provide the students with flashcards with the letters A, B, C, D, E, and F, and tell them that Alice, Bob, Carrie, Doug, Eleanor, and Frank are the members of the club. She will ask them what an election result will look like. It is possible that the student will move two of the cards up away from the rest of them. If this happens, she will ask him to interpret what he just did and ask if it would make a difference if he picked CD vs DC. The question will then be presented and the researcher will ask the students about the number of ways for the election to play out. The researcher will ask clarifying questions as the student works, but will not guide the student until he has finished counting.
 - Once the student completes the task, the researcher will again implement Devil’s Advocate by telling the student that Cal, a former student, found the answer to the problem without actually computing anything. She will provide Cal’s argument and will ask the student to refute or justify Cal’s argument.
- Alternative Argument(s)/Solution(s):
 - Cal’s: Tasks 2 and 3 are essentially the same problem. So, the answers will be the same. Since the answer to Task 2 was 30, the answer to Task 3 is 30 as well.

(4) 2-digit numbers

- Task:
 - Situation: A 2-digit number is a number formed by taking an integer from 1-9 and appending an integer from 0-9.
 - Question: How many 2-digit numbers are there?
- Framing: This is another 2-item arrangement problem. Once again, the solution set of the problem is small enough at the student can list out the elements. However, since the solution set (90 elements) is larger than the previous solution sets, it is possible that the students will feel the necessity to find a systematic manner of listing the elements of the set.
- Administration Protocol:
 - If the student does not employ the Standard Odometer strategy, then the researcher will provide scratch work by a former student, which lists the

numbers 10-99 in a table. See Karl's argument. The student will be asked to analyze this strategy. Then, he will be asked if this way of thinking about the solution set could have been used in the previous tasks.

- If the student does employ the Standard Odometer strategy, and Devil's Advocate to obtain double the number of elements has not been used yet, then the researcher will implement that argument (Carmen's) at this point.
- Alternative Argument(s)/Solution(s):
 - Karl's: First, we can hold a 1 constant in the 10's place and cycle through the possibilities for the 1s place. Then, we can hold a 2 constant in the 10s place and cycle through the possibilities for the 1s place. Continuing this process, we can organize the elements in the following manner.

10	20	30	40	50	60	70	80	90
11								
12								
13								
14								
15								
16								
17								
18								
19								

- Carmen's: First, we hold a digit constant in the 10s place and cycle through the choices for the 1s place, and we do this for all 9 possibilities for the 10s place. Then, we hold a digit constant in the 1s place and cycle through all the choices for the 10s place, and we do this for all the possibilities for the 1s. We add all of these together to get the total amount.

(5) Security Codes

- Task:
 - Situation: A security code for a computer involves two letters. It is case insensitive, but the two letters must be different from each other.
 - Question: How many possible security codes are there for this computer?
- Framing: By now, the student will have either stumbled upon the Odometer strategy or will have observed it in Karl's argument in task (4) 2-digit number. The hope is that students adopt the Odometer way of thinking on their own. The solution set to this problem is too large (26×25 elements) for students to easily list out its elements. As a result, it is likely that they will engage in the Standard Odometer way of thinking, which will be encouraged through Stimulating Questions, Contrasting Prompts and Devil's Advocate. Notice that this task is similar to the first two tasks, though students might not recognize this fact. It is likely that students will engage in the Deletion way of thinking, though if the students employ Standard Odometer with Anticipation, this may not happen.
- Administration Protocol:

- After students discuss with the researcher what a security code for this problem will look like, students will work through this task on their own.
- If the students employ the Odometer way of thinking with Anticipation, then David’s argument (Standard Odometer way of thinking with Deletion at the end) will be provided using Devil’s Advocate and students will be asked to discuss the similarities and differences between the two solutions.
- If the students employ Standard Odometer with Deletion, then Annie’s argument (Standard Odometer with Anticipation) will be provided using Devil’s (if the students engaged in Standard Odometer with Deletion in the middle, they may not view Annie’s argument as a different way of thinking – it will be interesting to observe whether they see the difference).
- If the students do not employ the Standard Odometer at all, then both the David’s and Annie’s arguments will be provided to them and students will be asked to discuss the similarities and differences between the two solutions.
- Alternative Argument(s)/Solution(s):
 - David 1: First we consider all two-letter strings which start with A. Then two-letter strings which start with B. Similarly, we consider all of the 26 two-letter strings which start with each of C through Z. But, there are two-letter strings which are not acceptable as security codes, so we have to take them out.
 - David 2:

AA	BA	CA	DA	. . .	YA	ZA
AB	BB	CB	DB		YB	ZB
AC	BC	CC	DC		YC	ZC
AD	BD	CD	DD		YD	ZD
.
.
.
AY	BY	CY	DY		YY	ZY
AZ	BZ	CZ	DZ	. . .	YZ	ZZ

$$(26 \times 26) - 26$$

- David 3: There are 26 two-letter strings which start with A: AA, AB, ..., AY, AZ. There are also 26 two-letter strings which start with B: BA, BB, ..., BY, BZ. Similarly, there are 26 two-letter strings which start with each of C through Z. Altogether, there are 26×26 total two-letter strings. Now, we have 26 two-letter strings which are not acceptable as security codes (AA, BB, CC, ..., ZZ). This idea is summarized in the table below. There are 26 columns, and 26 rows, but 26 two-letter strings are crossed out. Therefore, we have $(26 \times 26) - 26$ total security codes.

AA	BA	CA	DA	. . .	YA	ZA
AB	BB	CB	DB		YB	ZB
AC	BC	CC	DC		YC	ZC
AD	BD	CD	DD		YD	ZD
.
.
.
AY	BY	CY	DY		YY	ZY
AZ	BZ	CZ	DZ	. . .	YZ	ZZ

- Annie 1: First we consider the acceptable security codes which start with A. Then we consider the acceptable security codes which start with B. Similarly, we consider the acceptable security codes which start with each of C through Z.
- Annie 2:

A: B, C, D, E, F, ..., Y, Z
 B: A, C, D, E, F, ..., Y, Z
 C: A, B, D, E, F, ..., Y, Z
 D: A, B, C, E, F, ..., Y, Z
 .
 .
 .
 Y: A, B, C, D, E, ..., X, Z
 Z: A, B, C, D, E, ..., X, Y

$$26 \times 25$$

- Annie 3: There are 25 possible security codes which start with A: AB, AC, ..., AZ. There are also 25 possible security codes which start with B: BA, BC, ..., BZ. Similarly, there are 25 possible security codes which start with each of C through Z. This is summarized below. There are 26 letters A – Z, and when each is placed as the first letter in the security code, there are 25 possibilities for the second letter. Altogether, there are 26×25 possible security codes.

A: B, C, D, E, F, ..., Y, Z
 B: A, C, D, E, F, ..., Y, Z
 C: A, B, D, E, F, ..., Y, Z
 D: A, B, C, E, F, ..., Y, Z
 .
 .
 .
 Y: A, B, C, D, E, ..., X, Z
 Z: A, B, C, D, E, ..., X, Y

Paired Session 1:

In this session, the two students will work together to solve a variety of problems involving arrangements with and without repetition. They will work with different situations (identical elements, all three ICMs, etc.) This session is designed to further develop and reinforce the Odometer way of thinking, which will be foundational to developing future ways of thinking such as Equivalence Classes and Generalized Odometer. Students will also likely employ the Addition way of thinking.

(6) Books

- Task:
 - Situation: Suppose there are 5 different algebra books, 6 different geometry books, and 8 different calculus books.
 - Question: In how many ways can a person pick a pair of books if they must choose books on different subjects?
- Framing: Students have now employed or seen Alternative Argument(s)/Solution(s) driven by the Standard Odometer way of thinking in Individual Interview 1. Because of the cardinality of the solution set to this problem, students will likely engage in the Standard Odometer way of thinking. Furthermore, the problem will likely require the Addition or Partition ways of thinking. The researcher will observe whether students view these ways of thinking as the same thing.
- Administration Protocol:
 - Students will first be asked to interpret the problem. They will be asked what it means to pick books from different subjects. They will be asked how they can keep track of different pairs. They will then work together to solve the problem. They will be asked to discuss their reasoning with each other.
 - If the students first partition the solution set and then find the cardinality of each part, the instructor will implement Contrasting Prompts/Devil's Advocate: the students will be provided with Gil's solution driven by the Addition way of thinking which first determines the number of pairs involving an Algebra book and then determines the number of pairs involving Geometry and Calculus. They will be asked to discuss the similarities and differences in the solutions and the corresponding reasoning.
 - If the students first determine the number of pairs involving an Algebra book and then determines the number of pairs involving Geometry and Calculus, the instructor will implement Contrasting Prompts/Devil's Advocate: the students will be provided with Polly's solution driven by the Partition way of thinking which first partitions the solution set and then determines the

cardinality of each set. They will be asked to discuss the similarities and differences in the solutions and the corresponding reasoning.

- Alternative Argument(s)/Solution(s):
 - Addison 1: First we find the number of pairs involving an algebra book, then we find the number of remaining pairs, and we add all of these together. There are 5 algebra books and each one can be paired with one of the 6 Geometry books or one of the 8 Calculus books. All that remains is the pair the Geometry books with the Calculus books. There are 6 Geometry books and each one can be paired with one of the 8 Calculus books.
 - Addison 2: Each algebra book can be paired with one of the Geometry books or one of the Calculus books. So, each algebra book can be paired with $6+8=14$ other books. Since there are 5 algebra books and this is true for each algebra book, there are 5×14 total pairs with an Algebra book. Now, the Geometry books have already been paired with the Algebra books so we need to pair the Geometry books with the Calculus books. Each Geometry book can be paired with 8 Calculus books. Since there are 6 Geometry books, there are a total of 6×8 pairs consisting of Geometry and Calculus books. Since all of the books have now been paired together, we have a total of $5 \times 14 + 6 \times 8$ pairs of books.
 - Polly 1: We have three different cases based on the types of books chosen: we can either have an Algebra book and a Geometry book, an Algebra book and a Calculus book, or a Geometry book and a Calculus book. If we find the number of each type of pair, we can add them all together to find the total number of pairs with different books.
 - Polly 2: We have three different cases based on the types of books chosen: We can either have an Algebra book and a Geometry book, an Algebra book and a Calculus book, or a Geometry book and a Calculus book. Each Algebra book can be paired with 6 Geometry books, so we have 5×6 pairs with Algebra and Geometry. Each Algebra book can be paired with 8 Calculus books, so we have 5×8 pairs with Algebra and Calculus. Finally, each Geometry book can be paired with 8 Calculus books, so we have 6×8 pairs with Algebra and Calculus. Altogether, we have $5 \times 6 + 5 \times 8 + 6 \times 8$ total pairs of books from different subjects.

(7) Balls

- Task:
 - Situation: Suppose a store has a bin with 5 indistinguishable tennis balls and 8 indistinguishable golf balls.
 - Question: In how many ways can I buy at least one ball from this store?
- Framing: This is the first task where students have to contend with identical objects. This is another arrangement problem, however, students are no longer arranging the individual items (the balls), but the amount of each type of item..
- Administration Protocol:
 - The researcher will provide the students with 5 tennis balls and 8 golf balls. They will be asked to demonstrate what a purchase would look like. They will be asked what it means that the balls are “indistinguishable”. They will then be allowed to work on their own.

- If the students treat the balls as distinct items, the researcher will discuss the meaning of “indistinguishable/identical” in traditional combinatorics textbooks. In particular, she will tell the students that objects are indistinguishable if they have no individualizing characteristics. In this problem involving indistinguishable balls, it means that it does not matter which particular golf ball I buy. She will demonstrate to the students that buying 1 tennis ball and 2 golf balls is the same as buying another tennis ball and 2 golf balls. She will ask the students to take 30 seconds to think about what will make one purchase different from another. Using All Purpose Go Around the students will discuss their answers. The students will then be asked to solve the problem with this in mind.
- If students do not employ the Standard Odometer way of thinking (most likely because they engaged in the Addition way of thinking and partition the solution set by the number of balls purchased), the researcher will implement Contrasting Prompts/Devil’s Advocate by providing the students with Sally’s argument. The students will be asked to discuss this alternative solution and its validity. If the students do not realize that Sally forgot to subtract the empty set, the researcher will ask them to compare the size of the supposed solution set in each arguments. The students should revise Sally’s argument and then contrast this argument with their own.
- Alternative Argument(s)/Solution(s):
 - Sally: A purchase does not depend on the particular balls which are chosen, but instead on the number of each type of ball. Now, you can buy no tennis balls, 1 tennis ball, 2 tennis balls, up through 5 tennis balls. For each of these, you can buy 0 – 8 golf balls. So, for each number of tennis balls chosen, there are 9 choices for the number of golf balls in the purchase.

• Sal:

(0,0)	(0,1)	(0,2)	(0,3)	(0,4)	(0,5)	(0,6)	(0,7)	(0,8)
(1,0)								
(2,0)								
(3,0)								
(4,0)								
(5,0)								(5,8)

(8) Fraternities

- Task
 - Situation: There are 24 letters in the Greek alphabet. Fraternity names involve 3 Greek letters.
 - Questions:
 - How many fraternities may be specified by choosing 3 Greek letters if repetitions are not allowed?
 - How many fraternities may be specified by choosing 3 Greek letters if repetitions are allowed?
- Framing: The first question is a typical arrangement problem, but a 3-item arrangement problem, which the students have not yet encountered. Then, the

students will encounter a 3-item arrangement with repetition problem in the second question. Students will have to determine the meaning of “repetitions”. This problem has a Selection ICM. The following problems might have other ICMs.

- Administration Protocol:
 - Students will first encounter the first question. They will be asked what “repetitions are not allowed” means. After they solve the first problem, they will encounter the second problem, and will be allowed to work on each as they wish to.
 - Once the students complete the problem, they will be asked to discuss the differences, if any, between the ways of thinking involved in each question. In this way, the questions serve as Contrasting Prompts.

(9) Garage, Bat 9, D

- Task:
 - Situation: The garage in Angel’s building has five numbered places. This is the plan of the garage: 1 2 3 4 5
As the building is very new, at the moment there are only three residents, Angel, Beatrice, and Carmen who would need to park their cars in the garage. They each have only one car.
 - Question: In how many different ways could Angel, Beatrice, and Carmen park their cars in the garage?
- Framing: This task is an arrangement problem without repetition which involves a Distribution ICM. This task was chosen to deepen the Standard Odometer way of thinking by applying it to different situations and ICMs.
- Administration Protocol:
 - Students will be allowed to work with the flashcards with A, B, and C on them.
 - The students will be asked to discuss the situation with each other and determine the size of the solution set. The researcher might implement Stimulating Questions, but will not use any other type of Instructional Provocation.

(10) Cars, Bat 4, Part

- Task:
 - Situation: A boy has five different colored cars (black, orange, white, red, and grey) and he decides to distribute the cars between his friends Peggy, John and Linda.
 - Question: In how many different ways can he distribute the all of the cars to his friends?
- Framing: This is another arrangement problem with repetition. In this case, it is phrased with a Partition ICM. This task was chosen to deepen the Standard Odometer way of thinking by applying it to different situations and ICMs. Further, there is evidence that students might view the colors of the cars as extraneous information (Godino et al., 2005). The researcher will have an opportunity to observe whether the students in this study view this situation in the same manner.
- Administration Protocol:

- First, the students will be asked to read the situation and determine if there is any superfluous information.
- The students will be asked to discuss the situation with each other and determine the size of the solution set.
- If the students struggle with this task and focus on determining the number of ways the boy could give the cars to one person, the researcher will say that a former student would have said that they were looking at the problem from the people’s perspective and should instead look at it from the car’s perspective. She will ask the students what they think of this statement.
- Once the students complete this task, they will be asked to compare and contrast this task with the previous task. The researcher will ask the students “Can you compare and contrast the situation in this task with the situation in the Garage task we just completed? How are they similar? How are they different? What do these differences mean in terms of the solution sets?” The two tasks will thus serve as Contrasting Prompts.
- Alternate Arguments/Solutions:
 - Paul: We consider the cars that each person could get:

Peggy	John	Linda
B,O,W	R	G
B,O,W	G	R
B,O,R	W	G
B,O,R	G	W
B,O,G	W	R
.		
.		
.		

- Carly: We consider the people that each car could go to:

$$\frac{\overline{3333}}{B O W R G}$$

Paired Session 2:

In this paired session, students will further develop the Odometer way of thinking, apply this way of thinking to other arrangement problems with and without repetition, and encounter the selection and distribution ICMs. Ideally, students will develop the tree diagram as a way to visually represent the Standard Odometer way of thinking. In addition, students will be introduced to the Wacky Odometer way of thinking in the hopes that this way of thinking will aid the transition to Generalized Odometer way of thinking later in the study. The tree-diagram representation will hopefully help students contrast the Standard and Wacky Odometer ways of thinking, and deepen their understanding of both.

(11) Grandma, Bat 6, D

- Task:
 - Situation: Four children: Alice, Bert, Carol, and Diana go to spend the night at their grandmother's home. She has two different rooms available (one downstairs and another upstairs) in which she could place all or some of the children to sleep.
 - Question: In how many different ways can the grandmother place the children in the two different rooms?
- Framing: This task is another arrangement with repetition problem, but it involves a Distribution ICM. This task was chosen to deepen the Standard Odometer way of thinking by applying it to different situations and ICMs. This task will serve as a warm-up for the session, as well as an introduction to tree diagrams.
- Administration Protocol:
 - Students will be allowed to work with the flashcards to find the size of the solution set.
 - Batanero et al. (1997b) include in their question the following information: "For example she could use only one room to place the children, or she could place Alice, Bert, and Carol in the ground floor room and Diana in the upstairs room." If students struggle to understand the question, the researcher will provide them with that extra information.
 - Students will solve the problem and then be asked to discuss how they were thinking about generating the elements of the solution set. Ideally, they will state that they have different cases based on which room each child sleeps in. The researcher will ask the students to visually represent their way of thinking for this task.
 - They will be presented with Annette's tree diagram for the problem. They will be asked how the size of the solution set can be determined from the

given diagram. They will be asked to contrast Annette's solution and representation with their solution.

- Alternative Argument(s)/Solution(s):
 - Annette:

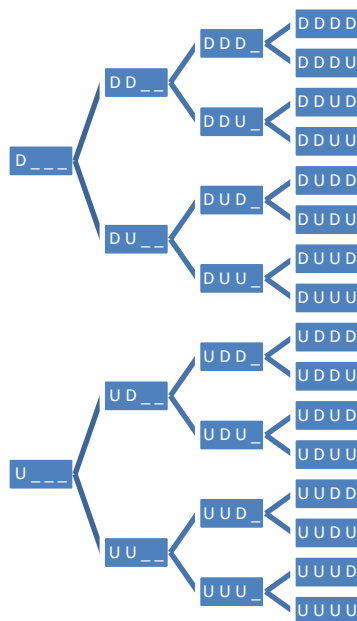

(12) Lotto Numbers, Bat 11, S

- Task:
 - Situation: In a box there are four numbered marbles (with the digits 2, 4, 7, and 9). We choose one of the marbles and note down its number. Then we put the marble back in the box. We repeat the process until we form a three-digit number, our Lotto number.
 - Question: How many different Lotto numbers is it possible to obtain?
- Framing: This is an arrangement with repetition problem which involves a Selection ICM. The students have not seen this ICM since the Fraternities problem. Furthermore, students will construct or see more tree diagrams.
- Administration Protocol:
 - The students will be asked if there is any superfluous information provided (this is to determine the students' understanding of putting the marble back in the box)
 - Students will then be asked to discuss the situation and find a solution to the problem.
 - Students will be asked to discuss how they were thinking about generating the elements of the solution set. Ideally, they will state that they have different cases based on the first marble chosen. For each of them, they have different cases based on the second marble chosen, etc. They will be asked if there is a way to visually represent this way of thinking about this problem.
 - Students will be presented with Toni's partial solution . They will be asked to complete Toni's solution, to explain why Toni knew to structure the tree-

diagram in this manner even though she didn't finish it, and how Toni was able to determine the size of the solution set from this tree diagram. For the last question, if the students are unable to answer it, the researcher will provide the rest of Toni's partial solution (there are 4 separate "webs", each web consists of 4 separate mini-webs, which each have 4 leaves. So we have $4 \cdot 4 \cdot 4 = 4^3$ total Lotto numbers), and will be asked to discuss the validity of Toni's explanation.

- If students had created a tree diagram where following the branches leads to something like $2 \rightarrow 2 \rightarrow 9$ in the representation they create for their own way of thinking, and students will be asked to contrast their representation with Toni's and to discuss the reasoning to use either.
- Alternative Argument(s)/Solution(s):
 - Toni:

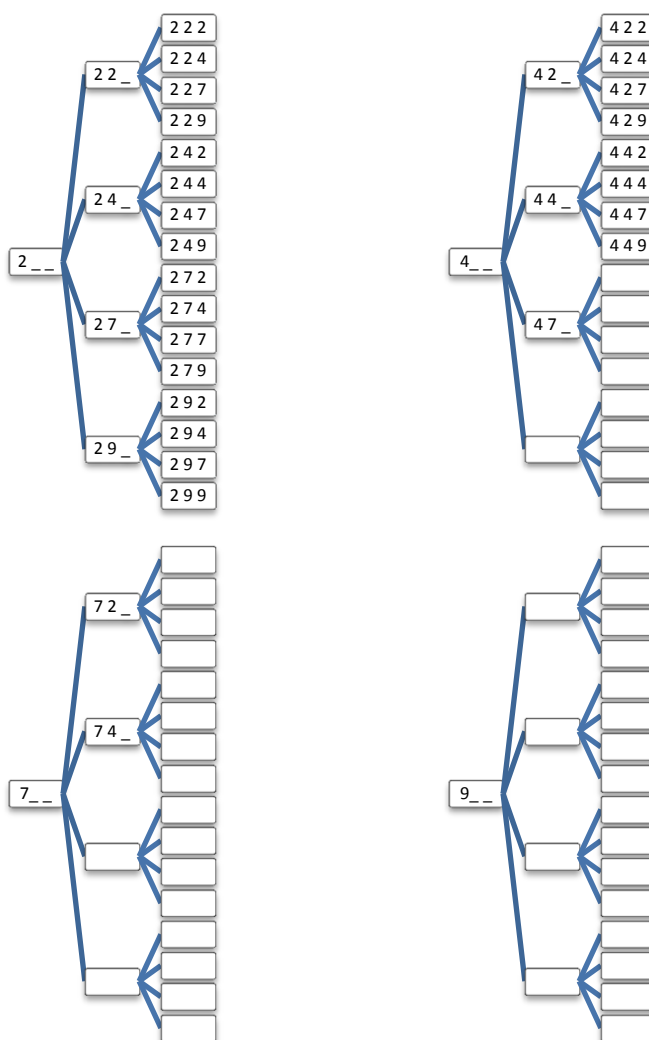

(13) Committee 2, Bat 13, S

- Task:

- Situation: A club needs a three member committee (president, treasurer, and secretary), and has 4 candidates (Arthur, Ben, Charles, and David).
- Question: How many different committees could be selected?
- Framing: The phrasing of the situation is similar to that of the 3rd task (Committee 1) used in the individual interview, but the students will now need to find a 3-element arrangement. It is likely that the students will not struggle with this task, however it provides a nice opportunity to introduce the Wacky Odometer way of thinking.
- Administration Protocol:
 - Students will be allowed to work with the flashcards with A-D on them.
 - Then, they will be provided with Walter's solution to the problem involving a tree diagram representing the Wacky Odometer way of thinking through Devil' Advocate. They will be asked to visually represent how they were thinking about the task and they will be asked to compare and contrast these two representations and ways of thinking.
- Alternative Argument(s)/Solution(s):
 - Walter:

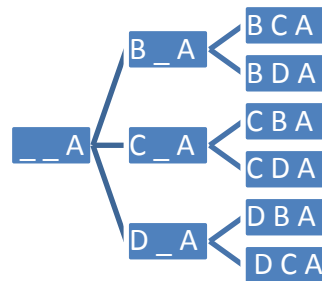
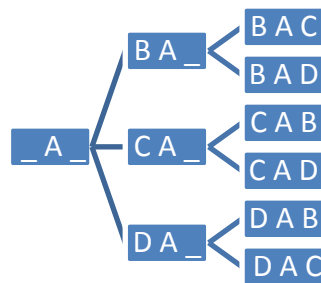
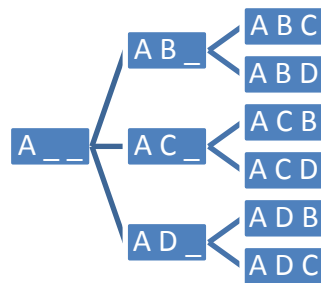

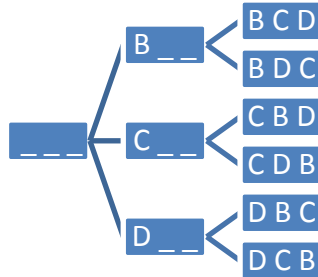

(14) Letters abcdef

- Task:
 - Situation: Suppose we have the letters a, b, c, d, e, f and we are forming three-letter strings of letters (“words”) from these letters.
 - Questions: How many 3-letters “words” can be formed from these letters if
 - i. Repetition of letters is not allowed
 - ii. Repetition of letters is not allowed and the letter “d” must be used.
 - iii. Repetition of letters is not allowed and either the letter “d” must be used or the letter “a” must be used, but not both
 - iv. Repetition of letters is not allowed and either the letter “d” must be used or the letter “a” must be used, or both must be used.
 - v. Repetition of letters is allowed
 - vi. Repetition of letters is allowed and the letter “d” must be used.
- Framing: This task is similar to the Fraternities problem, however, there are restrictions in the second and fourth tasks. The Addition way of thinking or Wacky Odometer will be necessary for the second question.
- Administration Protocol:
 - The questions will be provided to the students one at a time, and the students will be allowed to work with the flashcards A-F.
 - Students will be asked to solve the first problem on their own, and represent their solution visually.
 - They will then be provided with the second question. They will be asked what it means that the letter “d” must be used and then allowed to solve the problem however they like.
 - Students will solve the third and fourth problems however they like.
 - First, students will solve the fifth problem however they like. If they cannot solve it or solve it using neither Standard Odometer or Wacky Odometer, both Oscar and Carrie’s solutions to will be provided – one with overcounting, the other correct. Students will be asked to evaluate both. In this case, the solutions would serve as Contrasting Prompts and Devil’s Advocate. If the

students solve the problem using one method, the other will be provided using Devil's Advocate. The two solutions will serve as Contrasting Prompts.

- Once the students recognize the error in Oscar's solution, the researcher will provide Iuliana and Adam's arguments one at a time as Devil's Advocate. The students will be asked to contrast these arguments with Oscar's argument.
- Alternative Argument(s)/Solution(s):
 - Ian: We will first count all of the "words" possible including the letter "d", then all of the "words" including the letter "a". Since "words" including both "d" and "a" would then be counted twice – once in each of those terms, we will subtract the number of "words" using both to compensate:
 - If the letter "d" is used, then the word can either go d __, _d, __d. For each of these, there are 5×4 ways to place the other letters since repetition is not allowed. So there are $3 \times 5 \times 4$ "words" with the letter "d". Similarly, if the letter "a" is used, then there are $3 \times 5 \times 4$ ways to place the other letters. If we sum these terms, we have $(3 \times 5 \times 4) + (3 \times 5 \times 4)$.
Now, if both "a" and "d" are used, we could have ad_, da_, _ad, _da, a_d, d_a. For each of these, there are 4 "words" we can write. So there are 6×4 "words" using both "a" and "d". Each of these has been counted twice and we only want to count it once, so we must subtract this from our above sum:
 $(3 \times 5 \times 4) + (3 \times 5 \times 4) - (6 \times 4) = 96$.

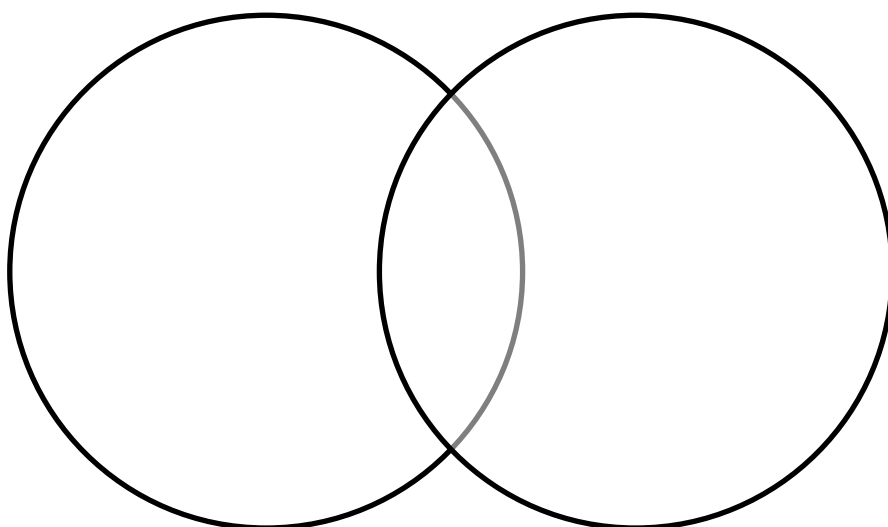

- Oscar: If d is first, then there are 6×6 ways to place the other letters. If it's second, then there are 6×6 ways to place the other letters. If it is third, there are 6×6 ways to place the other letters. In total there are $(6 \times 6) + (6 \times 6) + (6 \times 6) = 108$ "words".
- Carrie: We first determine the number of 3-letter "words" possible regardless of whether d is used: $6 \times 6 \times 6$ from question 3. Then, we determine the

number of “words” which do not include the letter “d”: $5 \times 5 \times 5$. Thus, there are $6^3 - 5^3$ “words” which include the letter d.

- Iuliana: If d is first, there are 6×6 ways to place the other letters. If it’s second, then there are 6×6 ways to place the other letters. If it is third, there are 6×6 ways to place the other letters. If we sum these terms, we get $(6 \times 6) + (6 \times 6) + (6 \times 6) = 108$ “words”.

However, this sum over-counts things of the form $dd_$ - it counts them once in the first term and once in the second, but we only want to count them once. There are 6 things of this type, so we need to subtract 6. Also, the sum over-counts things of the form d_d - it counts them once in the first term and once in the third, but we only want to count them once total. There are 6 things of this type so we need to subtract 6 from our sum. Similarly, we need to subtract 6 again because there are 6 things of the form $_dd$ which are counted twice in our sum - once in the 2nd term and once in the 3rd. Once we subtract, we have $(6 \times 6) + (6 \times 6) + (6 \times 6) - 6 - 6 - 6 = 90$.

But notice that ddd is something of the form $d__$ and $_d_$ and $__d$, It was counted once in each term of the sum (for a total of 3 times), but we subtracted it 3 times because it is of the form $dd_$, d_d , and $_dd$. So it’s not being counted at all in the 90 “words” we counted above. We need to add it back in: $(6 \times 6) + (6 \times 6) + (6 \times 6) - 6 - 6 - 6 + 1 = 91$.

- Adam: If d is first there are 6×6 ways to place the other letters. Now let’s think about what happens if d is second. We already counted everything that had d first, so we can’t have d first and second. Therefore, there are 5 options for the first letter and for each of them there are 6 options for the third. So there are 5×6 ways for the d to be second that we have not already counted. Finally, let’s think of what can happen if d is third. We already counted everything that had d first or second, so we can’t have d in either of those spots. So there are 5×5 ways to place d third that we have not already counted. Altogether we have $(6 \times 6) + (5 \times 6) + (5 \times 5) = 91$ total “words”.

(15) Boys and Perms, Bat 1, D

- Task:
 - Situation: Four boys are sent to the headmaster for cheating. They have to line up in a row outside the principal’s room and wait to speak to the principal individually. Suppose the boys are called Andrew, Burt, Charles and Dan (A, B, C, D, for short). We want to write down all the possible orders in which they could line up.
 - Question. In how many ways can the boys line up?
- Framing: This is the first permutation problem the students will encounter. It is likely that the students will not see much of a difference between this problem and the previous arrangement problems. The researcher will not formally discuss permutations with the students at this point. During data analysis, the ways of thinking students engage in while solving this problem will be contrasted with the ways of thinking students engage in while solving permutation problems in general.
- Administration Protocol:

- Students will be allowed to work with the flash cards A-D and find the size of the solution set.
- If students struggle to represent the situation, the researcher will provide them with a variation of the following: “For example: A (first), B (second), C (third), D(fourth), we write ABCD.” This sentence is from Batanero et. al (1997b)’s questionnaire.
- Once the students complete this task, they will be asked to compare and contrast this situation with the situations in previous tasks. The researcher will not react to their responses. As mentioned above, the students might not view this task as any different from the previous ones.

Individual Interview 2:

The first task (Task 16) in this session serves as a mid-study test. In particular, the researcher will have a chance to observe the students individually as they, hopefully, engage in one of the Odometer ways of thinking. This first task will be conducted in a clinical interview style. The rest of the session (Tasks 17 and 18) will be conducted in teaching experiment style and is extremely important in the development of students’ ways of thinking. In particular, the researcher will observe students’ initial ways of thinking as they develop the Equivalence Classes way of thinking. In particular, students will develop the combinatorial operation of permutations and what is colloquially referred to as “circle permutations”. Equivalence Classes thinking is extremely important in developing the operations of combinations and permutations with repetition. As a result, it is important that the researcher is able to closely attend to the development of each individual students’ ways of thinking.

(16) Sororities

- Task:
 - Situation: A university decides that sorority names can be three-letters chosen from the following Greek letters: $\Gamma, \Delta, \Theta, \Lambda, \Pi, \Phi, \Psi, \Omega$
 - Questions: How many sorority names can be formed from these letters if
 - Repetition of letters is not allowed and either the letter “ Φ ” or the letter “ Γ ” must be used, but not both.
 - Repetition of letters is allowed
 - Repetition of letters is allowed and the letter “ Θ ” must be used.

- Framing: This task will serve as a mid-study test. The researcher will observe the students' ways of thinking in this task as they solve it individually and without any interventions by the researcher. The task is very similar to Task 14: Letters abcdef. Students will likely engage some form of Odometer thinking,

(17) Perms in general

- Task:
 - Situation: This time a bunch of people are sent to the headmaster for cheating. They have to line up in a row outside of the head's room to wait to talk to him.
 - Question: In how many ways can n people line up in a row outside of the headmaster's office?
- Framing: This task is an extension of Task 15 "Boys and Perms". Students will hopefully apply the Odometer way of thinking (either Standard or Wacky) to this task. The researcher will introduce factorial notation in this task. This is one of the few times she will lecture.
- Administration Protocol:
 - The students will be allowed to work with a variety of flashcards. They will not be told to start with any particular n unless they struggle. If they do struggle, the researcher will suggest that they start with 1 card, then 2, and so forth.
 - If the students do not describe that there are $n(n-1)(n-2)\cdots 2\cdot 1$ ways to line up the n people, but have answers for particular n , the researcher will ask the student to consider the case of 3 boys and 4 boys. She will ask the student whether these cases are similar in any manner. If the student still struggles, she will take the fourth boy and ask "in how many ways can the other 3 boys be lined up if D is first? Why is that? How does that number relate to the 3-person problem? Let's think about the 3-person problem, how does it relate to the 2-person problem? Okay, so the solution set to the 4-person problem has 4-3-2-1 elements....What if we have 5 people? How does this relate to the 4-person problem? Can you generalize this?"
 - Once the students are able to state that there are $n(n-1)(n-2)\cdots 2\cdot 1$ ways to line up the n people, the researcher will introduce factorial notation. She will tell the students that in general, the number of ways to order n distinct objects in a row is $n!$. The student will construct a table with n and $n!$ as the columns for $n \in [7]$.

(18) Table

- Task:
 - Situation: A bunch of people would like to sit around a large, round table. It doesn't matter to them which particular seat they sit in, but they do care about the people who will be sitting to either side of them.
 - Question: In how many ways can n people sit around a circular table?
- Framing: This task will serve as an introduction to Equivalence Classes thinking, though students might not engage in that way of thinking at first.
- Administration Protocol:

- As always, the students will be presented with the situation and question. First they will discuss what the situation means. They will be allowed to use the flashcards with the letter A, B, C, and so forth. They will be asked to use the flashcards create different table settings. Once they do so, the researcher will provide pairs of table settings of her own using the cards and ask the students if they are the same or different. One pair will involve a flip; the other pair, a rotation. Following their responses, the researcher will further discuss the situation with the students, in order to communicate the traditional mathematical institution’s interpretation of the situation.
- The student will work as far through the problem on his own as he can. If he struggles and has not chosen to work with a small n , the researcher will suggest that he determines the number of ways for 1 person to sit at the table, 2 people, etc.
- If the student indicates that he would like to implement a recursive solution as he did for the previous problem (Task 17), the researcher will help him do so. There are two options for this, and the researcher will choose the option which suits the particular student best. In particular, if the student attempts to modify his strategy for Task 17: Perms in General where he held D constant, then the researcher will use the first option. Otherwise, she will use the second option.
 - “Okay, suppose we have student D sitting at the table. Now students A - C want to sit at the table too. In how many ways can they do so? Why? ...Now, what if we had 5 people, one sat down and the remaining 4 wish to do so too. In how many ways can they do so? Why? Can you generalize this?” [Broken Odometer]
 - “Suppose 3 people are sitting around a table. How many options are there for where student D can pull up a chair? Why? So how many total ways are there for 4 people to sit around this table? What if we wanted to seat 5 people around the table and 4 are already sitting, how many choices does the fifth person have about where to sit? Why? So how many ways total are there for the five people to sit around the table? Can you generalize this?” [let’s call this *Leaf-First Broken Odometer*]
- If the student attempts to draw the tables as if the seats are distinct and then use Deletion to remove the “invalid” elements [as Slang did in the pilot study], the researcher will ask why some elements are being discarded. She will then suggest that the student draws arrows between the element which is acceptable and those which are invalid because of it. Once the student completes the problem, the researcher will remind him that he was trying to use Deletion and ask him whether Deletion could be applied to arranging n people around the table. If he says “yes”, she will ask him how. If the student says “no”, she will ask what prompted him to change his mind.
- If the student struggles with the task and cannot even use Deletion, the researcher will provide Pat’s scratch work for Equivalence Classes from more generality to less (P1 through P3). They will then analyze the scratch work, be asked about its validity, and asked if they can generalize the technique.
- Devil’s Advocate and Contrasting Prompts will be used to provide these the remaining two solutions (from root-first Broken Odometer, leaf-first Broken

Odometer, and Equivalence Classes). Students will be asked to compare and contrast the three solutions, and asked about their preference.

- Arguments:

- Pat:

- P1:

ABCD	BCDA	CDAB	DABC
------	------	------	------

ABDC	BDCA	DCAB	CABD
------	------	------	------

ACBD	CBDA	BDAC	DACB
------	------	------	------

ACDB	CDBA	DBAC	BACD
------	------	------	------

ADBC	DBCA	BCAD	CADB
------	------	------	------

ADCB	DCBA	CBAD	BADC
------	------	------	------

- P2:

4



ABCD	BCDA	CDAB	DABC
------	------	------	------

ABDC	BDCA	DCAB	CABD
------	------	------	------

ACBD	CBDA	BDAC	DACB
------	------	------	------

ACDB	CDBA	DBAC	BACD
------	------	------	------

ADBC	DBCA	BCAD	CADB
------	------	------	------

ADCB

DCBA

CBAD

BADC

· P3:

$$4!/4 = \frac{4 \cdot 3 \cdot 2 \cdot 1}{4} = 3 \cdot 2 \cdot 1 = 3!.$$

- Bobby: We can sit the n th person at the table in 1 way. Once he's sitting down, it's like we have a line, not a circle left. Now, we need to permute the remaining $n-1$ people. We can do this in $(n-1)!$ ways. In total, we have $(n-1)!$ ways to seat people around the table.
- Isaac: We know that there is 1 way for two people to sit at the table. There are 2 ways for 3 people to sit at the table. Now, if 3 people were sitting at the table, and a 4th person shows up, there are 3 choices for where this person would sit. So altogether there are 6 ways for 4 people to sit. It seems as if there are $(n-1)!$ ways for n people to sit. Let's check to make sure this makes sense. It certainly does for $n=1, \dots, 4$. Now suppose that it is true for $k-1$. Suppose we have $k-1$ people sitting around the table. There were $[(k-1)-1]!$ ways for these people to sit. Now, the k th person has $k-1$ choices for where to sit. So altogether there are $(k-1)!$ ways for these k people to sit around. So it works for all possible values for n .

Paired Session 3:

The beginning tasks in this paired session are slight extensions of those in the previous individual interview. Students will gain familiarity with permutations by employing them in tasks involving different ICMs, and have an opportunity to engage in their newly-acquired Equivalence Classes way of thinking. The final task of this session is designed to help students develop the operation of combinations.

(19) Urn, Bat 5, S

- Task:
 - Situation: In an urn there are four marbles numbered with the digits 2, 4, 7, and 9. We extract a marble from the urn and note down its number. Without replacing the first marble, we extract another one and note down its number. Without replacing either marble, we extract another one and note down its number. Finally, we extract the last number from the urn and note down its number.

- Question: How many four-digit numbers can we obtain with this method?
- Framing: This task serves as a warm-up for the session. The Boys and Perms task (Task #15) in Paired Session 2 was a permutation problem of 4 items as this problem is. However, the Boys and Perms task involved a Distribution ICM and this task involves a Selection ICM. In addition, students encountered a very similar situation in Task 12: Lotto Numbers; however this problem is technically a permutation problem, where Task 12 is an arrangement problem.
- Administration Protocol:
 - Students will be presented with the situation and question. They will be allowed to work through the task as they wish. If they write their answer as 4-3-2-1, the researcher will point out that this equals 4!, and ask the students why this might be true.

(20) ATM

- Task:
 - Situation: A customer remembers that 2, 4, 7, 8, and 9 are the digits for a 5-digit access code for an automatic bank-teller machine. Unfortunately, the customer has forgotten the order of the digits.
 - Questions:
 - What is the largest possible number of trials necessary to obtain the correct code?
 - The customer suddenly remembers that the 2 comes right before the 9. Now what is the largest possible number of trails that is necessary to obtain the correct code?
 - She then remembers that the first number is 7 and the 2 comes right before the 9. Now what is the largest possible number of trails that is necessary to obtain the correct code?
- Framing: Students will have a chance to work together to apply permutations (or to treat these problems as the previous problems). From a mathematical standpoint, all three of these tasks involve permutations. However, we may observe whether actor-oriented transfer coincides with traditional transfer, since students might not view the second and third questions as involving permutations. In addition, it is possible that even if the students use 5! as an answer for the first problem, when presented with the second question, the student might not observe the relationship to permutations. This restriction might push the students to revert back to previous ways of thinking.
- Administration Protocol:
 - The questions will be provided to students one at a time and they will work as they usually do.
 - Once the students have finished working, if they did not consider 29 as one item in the second and third question, Lydia's argument will be provided for the third question. . The students will be asked if Lydia's argument could be modified for the second question.
- Alternative Argument(s)/Solution(s):
 - Lydia: Since the 2 comes directly before 9, we can consider 29 as one object. Now, we know that 7 comes first. After this, we need to order 4, 8, 29. We

can do this in $3!$ ways. For example, if we ordered 4, 8, 29 as 29, 4, 8, the pin number would be 72948.

(21) Necklace

- Task:
 - Situation: Amy has a bunch of beads to place on a necklace. Each bead has a different color.
 - Question: In how many ways can Amy place n beads on the necklace?
- Framing: This task is similar to the task 18: Table; however, flips of the circle are now identified as well. The researcher will have a chance to observe whether students engage in the Equivalence Classes thinking, and if they do so immediately or as a last resort. It seems unlikely that the students would be successful attempting a recursive solution as they did for the Perms and may have done for the Table problem.
- Administration Protocol:
 - The researcher will provide the students with different colored beads and a piece of string. She will ask the students to interpret the situation. She will ask them to create different necklaces. Then, she will provide a few necklace pairs on a sheet of paper to the students and ask them if they are the same or different, one pair will involve a rotation, another a flip, and a third both a rotation and a flip. Following their responses, the researcher will further discuss the situation with the students, in order to communicate the mathematical institution's interpretation of the situation.
 - The students will work as far through the problem on their own as they can. If they struggle and have not chosen to work with a small n , the researcher will suggest that they determine the number of ways for 1 bead to be placed on the necklace, 2 beads, etc.
 - If the students attempt to draw the necklaces as if the spots are distinct and then use Deletion to remove the "invalid" elements the researcher will ask why some elements are being discarded. She will then suggest that the students draw arrows between the element which is acceptable and those which are invalid because of it. Once the students complete the problem, the researcher will remind them that they originally tried to delete the invalid elements and ask them whether Deletion could be applied to arranging n beads around the necklace. If they say "yes", she will ask them how. If they say "no", she will ask what prompted them to change their mind.
 - If the students struggle to use Equivalence Classes, the researcher will ask them what new problem they have created. She will ask them to list the elements of its solution set and ask how these elements can be grouped.
 - Depending on whether the student uses Equivalence Classes with the new task of the Tables problem or the Perms problem, the researcher will provide the other argument to the students using Devil's Advocate and Contrasting Prompts. Note that two of the three prepared solutions involve the Perms problem but one uses Equivalence Classes once and the other uses it twice.
- Alternative Argument(s)/Solution(s):

- Penny: We know that we have $n!$ ways to arrange n beads in a row. Now, $2n$ of these rows correspond to the same necklace. See the example below. Since this is true for every necklace, we have $\frac{n!}{2n}$ possible necklaces.

For example, if we had 4 beads and the beads were numbered 1,2,3,4, then we can group the rows as follows:

1234, 2341, 3412, 4123, 4321, 3214, 2143, 1432
 1243, 2431, 4312, 3124, 3421, 4213, 2134, 1342
 1324, 3241, 2413, 4132, 4231, 2314, 3142, 1423

- Elise: We know that we have $n!$ ways to arrange n beads in a row. Now, we know that n of these rows correspond to the same Table (from task 18), so there are $\frac{n!}{n}$ possible table settings. But, there are two tables which

correspond to the same necklace and there are total of $\frac{\binom{n!}{n}}{2}$ total necklaces from n different colored beads.

For example, if we had 4 beads and the beads were numbered 1,2,3,4, then we can group the rows as show below. If we connect the first and last items, then each row corresponds to the same table. However, flips of the table create the

same necklace. So we have $\frac{\binom{4!}{4}}{2}$ total necklaces from 4 different colored beads.

1234, 2341, 3412, 4123 }
 1432, 4321, 3214, 2143 }

 1243, 2431, 4312, 3124 }
 1342, 3421, 4213, 2134 }

 1324, 3241, 2413, 4132 }
 1423, 4231, 2314, 3142 }

- Tania: We know that there are $(n-1)!$ ways to place n items around a table. But 2 tables correspond to the same necklace. See below for example. So we have $\frac{(n-1)!}{2}$ total necklaces.

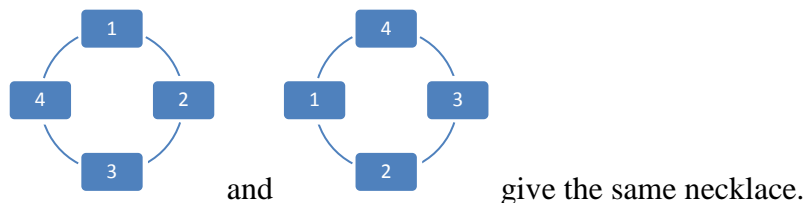

(22) Smoothies

- Task:
 - Situation: Mario has a bunch of different types of fruit to put into his smoothie.
 - Questions:
 - In how many ways can Mario make a smoothie with 2 types of fruit if he has n types of fruit to choose from?
 - In how many ways can Mario make a smoothie with 3 types of fruit if he has n types of fruit to choose from?
 - In how many ways can Mario make a smoothie with 4 types of fruit if he has n types of fruit to choose from?
 - In how many ways can Mario make a smoothie with k types of fruit if he has n types of fruit to choose from?
- Framing: This task serves as an introduction to combinations. Students will build up from 2-element subsets of n -elements to k -element subsets. They will most likely construct combinations from arrangements using Equivalence Classes. The notation for combinations will be given, but the explicit formula $\frac{n!}{(n-k)!k!}$ will not be.
- Administration Protocol:
 - The students will be provided first with the situation. As always, they will be asked to interpret the situation. Once the students present their interpretations of the question, the researcher will ask them how this situation compares with the situations in the other tasks. She will ask them how this new situation will affect how to find the size of the solution set.
 - The questions will be presented to the students in the order above. If the students struggle the researcher will ask them in how many ways the smoothie could be created if it mattered in which order the fruit was added. She then will ask them how the number of elements in the solution set of this new problem relates to those of the original task.
 - If the students still continue to struggle, the researcher will provide Jennifer's scratch work for the last question designed using Equivalence Classes. She will provide the table first, and if the students still struggle, she will then provide the argument.
 - Once the students have completed the task, the researcher will introduce the notation for combinations in the following manner: "The number of ways to

choose k elements from a total of n distinct objects is ‘ n choose k ’ and is denoted $\binom{n}{k}$.

- Alternative Argument(s)/Solutions(s):

- Jenifer:

- J1: $n=5$ types of fruit, 3 fruits in smoothie. There are 10 smoothies.

ABC	ACB	BAC	BCA	CAB	CBA
ABD	ADB	BAD	BDA	DAB	DBA
ABE	AEB	BAE	BEA	EAB	EBA
ACD	ADC	CAD	CDA	DAC	DCA
ACE	AEC	CAE	CEA	EAC	ECA
ADE	AED	DAE	DEA	EAD	EDA
BCD	BDC	CBD	CDB	DBC	DCB
BCE	BEC	CBE	CEB	EBC	ECB
BDE	BED	DBE	DEB	EBD	EDB
CDE	CED	DCE	DEC	ECD	EDC

- J2: Let’s see how this works for $n=5$. We know that the number of ways to order 3 fruits from 5 fruits is $5 \times 4 \times 3$. Now consider ABC. This has the same fruits as ACB, BAC, BCA, CAB, and CBA, and all of these will therefore create the same smoothie. In fact, this is true for each order of the fruit we found. We can organize the table as it is below. Since the number of ways to order 3 things is $3!$, we have $3!$ things in each row which will create the same smoothie. This means that we will have $\frac{5 \times 4 \times 3}{3!}$ ways to create a smoothie with 3 types of fruit when we have 5 types of fruit to choose from.

Paired Session 4:

In this paired session, students will gain familiarity with combinations. Now that students have been exposed to the notation of combinations, students will not be required to determine the numerical cardinality of a solution set. In other words, students will be able to leave their answers in the form $\binom{6}{2}$ instead of simplifying to 15. The last task (Task 26) is a permutation with repetition problem. This task is similar to the first task in

Individual Interview 1. Students will be introduced to the Generalized Odometer way of thinking in that problem.

(23) Envelopes, Bat 3 D

- Task:
 - Situation: Supposing we have three identical letters, we want to place them into four different colored envelopes: yellow, blue, red and green. It is only possible to introduce one letter in each different envelope.
 - Question: How many ways can the three identical letters be placed into the four different envelopes?
- Framing: This task involves a Distribution ICM and the operation of combinations. Now that students have seen combinations, they might transfer this knowledge to this problem. However, since combinations is still fairly new to students, they might not.
- Administration Protocol:
 - If the students seem confused about what the question is asking, the researcher will provide them with the following sentence taken from Batanero et al.'s (1997) questionnaire: For example, we could introduce a letter into the yellow envelope, another into the blue envelope and the last one into the green envelope.
 - The researcher will allow the students to work through the problem on their own. Then, she will provide Eddie or Camile's (or both if the students used a different solution) solutions using Devil's Advocate/Contrasting Prompts The students will be asked to compare and contrast the solutions.
- Alternative Argument(s)/Solutions(s):
 - Eddie: Suppose the letters are different and are labeled 1, 2, and 3. Then there are four possible envelopes for the first letter, 3 choices for the second letter, and 2 choices for the third letter. For example, YBG would correspond to the first letter going into the yellow envelope, the second letter going into the blue envelope, and the third getting placed in the green envelope. In total there are ways if the letters are different. But, since the letters are not different, YBG is the same thing as YGB, BGY, BYG, GBY, GYB. So, each ordering of envelopes is equivalent to its permutations. Since there are $3!$ permutations of 3 envelopes, we have a total of $\frac{4 \times 3 \times 2}{3!}$ total possibilities for envelopes.
 - Camile: We need to put the letters into 3 envelopes, but it doesn't matter which letter goes in which of the chosen envelopes. So, we need to choose 3 elements from 4 elements. We can do this in $\binom{4}{3}$ ways.

(24) Blackboard, Bat 8, S

- Task:
 - Situation: Five pupils Elisabeth, Ferdinand, George, Lucy and Mary have volunteered to help the teacher in erasing the blackboard.

- Question: In how many different ways can the teacher select three of the five pupils?
- Framing: This task involves a Selection ICM and the operation of combinations.
- Administration Protocol:
 - If the students seem confused about what the question is asking, the researcher will state “For example he could select Elisabeth, Mary and George.” This sentence was adopted from Batanero et al.’s (1997) questionnaire.
 - Once the students determine a solution such as $\binom{5}{3}$, the researcher will ask if they can think about it in a way similar to Eddie during task 23. Then, she will ask them if they can visually represent their thinking.

(25) Stamps, Bat 10, Part

- Task:
 - Situation: Mary and Cindy have four stamps numbered from 1 to 4. They decide to share out the stamps, two for each of them.
 - Question: In how many ways can they share out the stamps?
- Framing: This task is a Partition ICM with combinations.
- Administration Protocol:
 - Once the students determine a solution such as $\binom{4}{2}$, the researcher will ask if they can think about it in a way similar to Eddie during task 23. Then, she will ask them if they can visually represent their thinking. Arizona
- Task:
 - Situation: Remember that Arizona has 7-character license plates. In an attempt to foster state pride, the DOT agreed to provide citizens who use the letters in the word “ARIZONA” arranged in any order with a special license plate with an image of the a Saguaro Cactus and the Cactus Wren as the background.
 - Question: How many of these special license plates must the state create?
- Framing: This task is stated in a similar manner to the first task the students encountered, though it might be deemed “easier” since the Equivalence Classes used for permutations “Arizona” have size 2 instead of 4!4!2!. With the exception of the first task, this will be the first time students encounter permutations with repeated elements. Since “A” and “a” appear differently, this was chosen so that students might easily transition to treating the elements as if they were distinct and then “flattening” the choices using Equivalence Classes.
- Administration Protocol:
 - Students will be asked to interpret the task and what it is asking them to count. They will be asked how they might attempt the problem.
 - If the students struggle and had introduced the concept of treating the letters as distinct in Task 1, the researcher will remind them of this idea. If they did not introduce that idea before, she might do so here. She will suggest that they write “ARIZONA” as “Arizona” so that the A’s appear differently. Before the students actually count the number of permutations of “Arizona”, the researcher will ask the students why this number might help them.

- The researcher will remind the students of their initial ideas for task 1 Mississippi I. She will ask them to compare those ideas with the ones they have for this task.
- Finally, she will provide them with Gary’s solution driven by the Generalized Odometer way of thinking. She will ask them about the validity of this solution and to compare the two solutions.
- Alternative Argument(s)/Solutions(s):
 - Evan: First, we will determine the number of permutations of “Arizona” there are. Here, we view “A” and “a” as different things. There are 7! ways to permute these letters. Indeed, there are 7 letters that can go first. For each one of them, there are 6 letters that can go second; for each one of those, there are 5 letters that can go third, and so forth. See the tree diagram below. Now, multiple permutations of “Arizona” will yield the same license plate. For example, “riAzona” and “riazonA” will both give the license plate “RIAZONA”. In fact, each permutation of “Arizona” has a partner created by swapping the “A” with the “a”. This means that there are 2 times as many permutations of “Arizona” as there are license plates. So, our solution is $\frac{7!}{2}$.

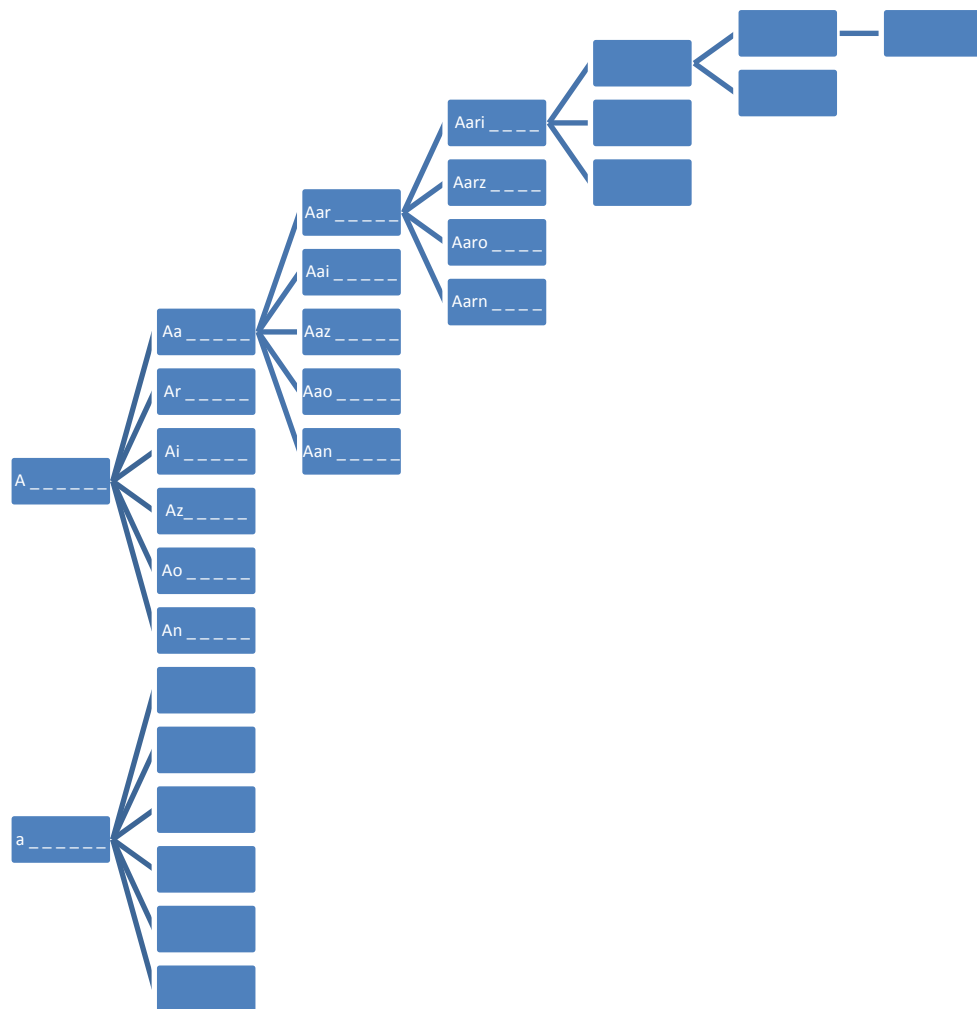

- Gary: First we choose where the A's go. Since there are 7 spaces in the license plate, we can place these items in $\binom{7}{2}$ ways. Each one of these placements leaves 5 empty spots, and, since 5 distinct letters need to go in these empty spots, each placement will create $5!$ license plates. Since there are $\binom{7}{2}$ placements, we have $\binom{7}{2} \cdot 5!$ total license plates.

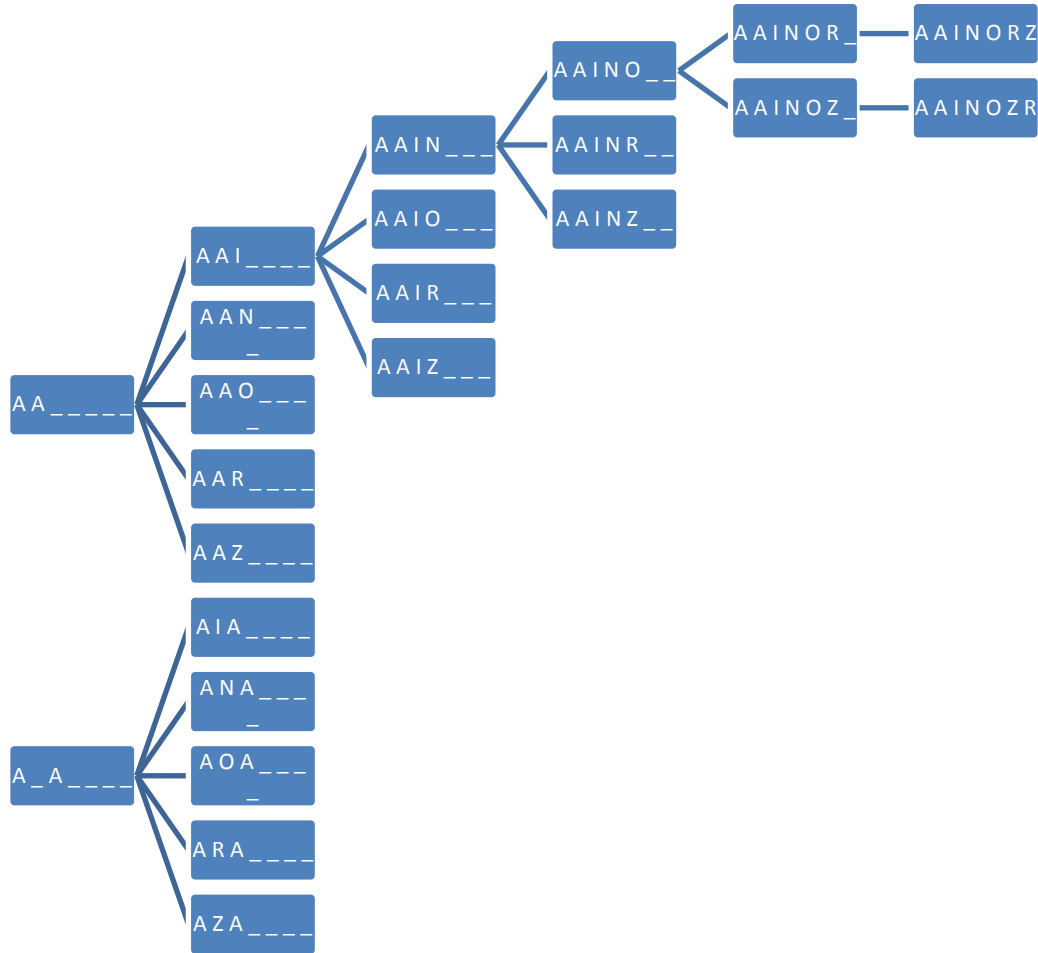

Paired Session 5:

This is the last of the paired sessions. Students will gain familiarity with permutations with repeated elements in problems with all three ICMs. They will have an opportunity to review other combinatorial operations and ways of thinking in the last

task. They will ideally engage in both Equivalence Classes and Generalized Odometer ways of thinking.

(26) Counters, Bat 2, S

- Task:
 - Situation: In a box there are four colored counters: two of them are blue, another is black and the last one is red. We take one of the counters at random and we note down its color. We take another counter at random from the box without replacing the first one. We continue this process until we have selected all four counters.
 - Question: In how many different ways is it possible to select the counters?
- Framing: This is a permutation with repetitions problem which involves a Selection ICM. In addition, the researcher will re-enforce the Generalized Odometer and Equivalence Classes ways of thinking by presenting them as possible solutions.
- Administration Protocol:
 - If the students seem to struggle, the researcher will say “For example we could select the counters in the following sequence: black, blue, red and blue.” This was taken from Batenero et al.’s (1997) questionnaire.
 - The researcher will ask the students to interpret the problem and whether there is any superfluous information. She will ask how the fact that there are 2 blue counters will affect their solution.
 - Once the students have reached a conclusion, the researcher will present either Ellis or Genny’s solutions. If they used Equivalence Classes, she will present Genny’s, if they used Generalized Odometer, she will present Ellis’s. If they use neither (and perhaps use Computer Program), she will present both prepared solutions.
- Alternative Argument(s)/Solutions(s):
 - Ellis: Suppose the blues are different shades instead. We have the following items: ● ● ● ● ●. First, we think of the number of ways to order these distinct counters. But, we don’t have different shades of blue. So ● ● ● ● ● is the same thing as ● ● ● ● ●. Both are the same as ● ● ● ● ●. Now, we need to think of how many times more counters we’ve counted than we want to count. We adjust our initial answer accordingly.
 - Genny: First we choose where the blue counters go. Each one of these placements leaves empty spots, and we can count the number of ways the red and the black counters can go in these empty spots.

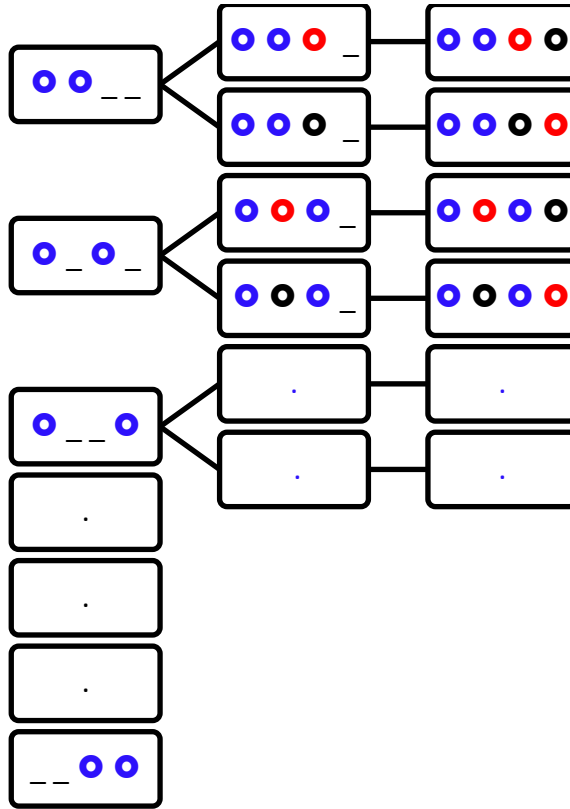

(27) Projects, Bat 7, Part

- Task:
 - Situation: Four friends Ann, Beatrice, Cathy and David must complete two different projects: one in Mathematics and the other one in Language. They decide to split up into two groups of two pupils, so that each group could perform one of the projects.
 - Question: In how many different ways can the group of four pupils be divided to perform these projects?
- Framing: This is a permutation with repetitions problem which involves a Selection ICM. The researcher might gain some insight about whether students reason differently when presented with problems with different ICM. In addition, it is less likely the students will engage in Computer Program for this task since Equivalence Classes and Generalized Odometer will have been presented in the previous task. She will re-inforce the Generalized Odometer and Equivalence Classes ways of thinking by asking the students to consider alternate solutions to the task.
- Administration Protocol:
 - If the students seem confused, she will state “For example, Ann and Cathy could complete the Mathematics project and Beatrice and David the Language project.”

- Once the students complete the task, she will ask them to consider the alternate solutions to the task based on Generalized Odometer and Equivalence Classes thinking.
- Alternative Argument(s)/Solutions(s)
 - Sean: We can split this problem up into different stages. In stage 1, we pick the students who will complete the Math project. In stage 2, we pick the students who will complete the Language project from the remaining people. There are $\binom{4}{2}$ ways to choose the people for Math in stage 1. We are then left with choosing 2 of the remaining 2 students for the Language project in $\binom{2}{2}$ ways. Altogether, we have $\binom{4}{2} \times \binom{2}{2}$ total ways to choose the students for the task. We could notice that there is only one way to choose 2 people from 2 choices, so we really have $\binom{4}{2}$ ways to choose the students.
 - Vince: We can think of this task as passing out the letters $L L M M$ to the students. Say the first letter gets passed to Ann, the second to Beatrice, the third to Cathy and the last to David. Then, we have the problem of ordering $L L M M$. Now, if we had 2 different Language projects and two different math projects, we could call them L_1, L_2, M_1, M_2 . Then, we would have 4 distinct objects to permute in $4!$ ways. But, $L_1 L_2 M_1 M_2$ is the same as $L_2 L_1 M_1 M_2$. In both of them, Ann and Beatrice would work on Language. So we can write $L_1 L_2 M_1 M_2$ as $LLM_1 M_2$. Notice that this is because there are $2!$ times more ways to arrange L_1, L_2, M_1, M_2 than there are to arrange L, L, M_1, M_2 . So, we divide $4!$ by $2!$ to compensate. But $LLM_2 M_1$ is the same as $LLM_2 M_1$. By the same argument, we have to divide $\frac{4!}{2!}$ by $2!$ again. See below:

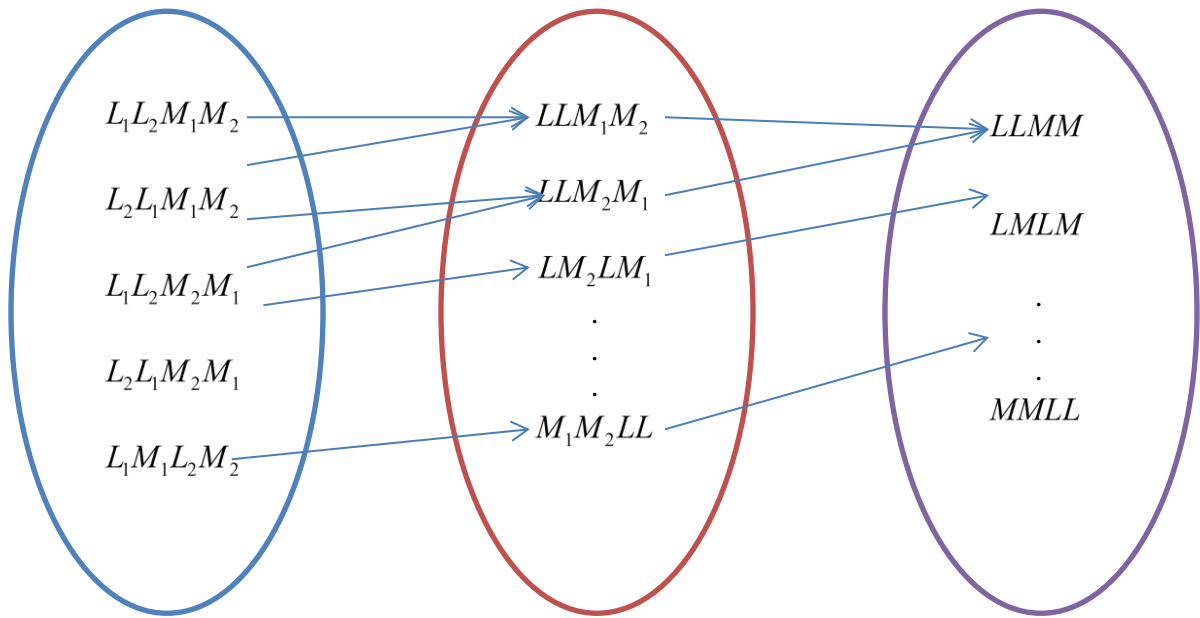

(28) Cards, Bat 12, D

- Task:
 - Situation: Each one of five cards has a letter: A, B, C, C, and C.
 - Question: In how many different ways can I form a row by placing the five cards on the table?
- Framing: This is a permutation with repetitions problem which involves a Distribution ICM.
- Administration Protocol:
 - The researcher will ask the students what it means for there to be 3 C's.
 - If the students seem confused she will state "For example I could place the cards in the following way: ACBCC."

(29) Wellesley

- Task:
 - Situation: Consider the word *WELLESLEY*. We will be forming "words" from these letters.
 - Question: How many "words" can be formed from the letters in "WELLESLEY" if:
 - i. We need 9-letter words created by rearranging the letters provided?
 - ii. We need 9-letter words created by rearranging the letters provided, and all of the L's are next to each other?
 - iii. We need 9-letter words created by rearranging the letters provided, and the Y comes before the S and the W?
 - iv. We need 9-letter words and each letter may be used any number of times?
 - v. We need 4-letter words, each letter may be used multiple times, and we must use the letter "E"?
- Framing: This task is an attempt to tie together many of the concepts from this study. The first question asks students to find permutations of a multi-set as they

had done in the rest of this session. The second question might require students to treat the L's as one item and create a new problem. The third question will likely require students to engage in the Generalized Odometer way of thinking or Generalized Odometer with Equivalence Classes. The fourth problem is something they have not yet seen before. It requires students to recognize that there are really only 5 types of items used (W E L S Y), and then to connect this to arrangements of repeated elements, which they have not done in a while. Finally, the last question again uses arrangements of repeated elements, along with Deletion to subtract the number of arrangements which do not involve E.

- Administration Protocol:
 - Each question will be presented one at a time and students will be asked to interpret each.
 - Students might struggle with the third question. The researcher will allow them to struggle for a while, and then ask them to think about the Generalized Odometer solutions to the other problems. She will remind them that in those other problems, they dealt with the most trouble-some aspect of the problems first (the repeated elements). She will ask them if there is a way to extend that idea to this task. She will ask them what the most trouble-some aspect of the task is and if they have any ideas for how to tackle it.
 - Students might also struggle with the last two tasks. The researcher will discuss with the students what it means that each letter may be used any number of times. If the students provide the answer, the researcher will ask the students to interpret their solution visually and/or provide an element of the solution set which is being over counted. She will ask them to adjust their solution.
 - For the last task, the researcher will ask how we can ensure that the word we create includes the letter "E". She will let the students work (they might attempt to use Addition), and, if they struggle will use Stimulating Questions to help them identify errors in reasoning. If they struggle, the researcher might ask how the last two questions are related, if at all, and if they can write another problem which might be related and helpful. She might remind them that, in the past, they counted the size of the solution set to other problems and then adjusted. She will then ask them how they could adjust their solution to the previous task.

Individual Interview 3:

This final task will serve as a post-test of sorts. Notice that the first question is a more conventional phrasing of Task 1. Students will have been asked to type up an explanation of the ways of thinking one must engage in to solve the first question before the interview. Students will discuss their write-up with the researcher and may provide an alternate solution to the first task in the interview. As a result, students will likely engage

in both Equivalence Classes and Generalized Odometer ways of thinking. In addition, they will likely engage in Deletion as well.

(30) Mississippi II

- Task:
 - Situation: Consider the word *MISSISSIPPI*. We will be forming “words” from these letters.
 - Question: How many “words” can be formed from the letters in “MISSISSIPPI” if:
 - i. We need 11-letter words created by rearranging the letters provided?
 - ii. We need 11-letter words created by rearranging the letters provided, and none of the *P*’s are next to each other?
 - iii. We need 11-letter words created by rearranging the letters provided, and all of the *I*’s come before the *S*’s and the *M*?
 - iv. We need 5-letter words, each letter may be used multiple times, and we cannot use the letter “P”?
- Framing: As stated above, this task will serve as a post-test. The students will have written a document discussing the ways of thinking involved in solving the first question. He will likely provide an alternate way of thinking as well. The second question is similar to the second question from the Wellesley problem above, but it involves Deletion, which the question above did not. The third question might require the Generalized Odometer way of thinking. The final question is a slight variation of the last question in the Wellesley problem, but it does not involve Deletion.
- Administration Protocol:
 - The researcher will discuss this question with the student and his provided solution and explanation. She might ask him if he could discuss any other ways of thinking which could be involved in solving the question.
 - The researcher will adopt a Clinical Interview style for the remaining questions, meaning she will ask clarifying questions, but will not intervene to guide the student to the solution.
 - Finally, the researcher will ask the student for his impression of the task for the day, as well as his impressions of the study in general.

APPENDIX B
SAMPLE CONTENT LOG

Dissertation Study Phase 1

Content Log: PS2

February 20, 2012

1) 0:02:29 – 0:17:39 Task 11: Grandma, Bat 6, D

- Task:
 - Situation: Four children: Alice, Bert, Carol, and Diana go to spend the night at their grandmother's home. She has two different rooms available (one on the ground floor and another upstairs) in which she could place all or some of the children to sleep.
 - Question: In how many different ways can the grandmother place the children in the two different rooms?
- The students briefly recap PS1 by saying that the tasks were more complicated than in II1 and the answer was not immediately apparent like they had been in II1.
- At 0:04:58, the students give their initial thoughts.
- Kate was thinking about it in terms of the number of ways to put the students into two different groups. She said that she actually just needs to find the number of ways to get one group because then the other group is defined by the remaining children.
- She said that it could be A, AB, AC, AD, ABC, ABD, ACD, ABCD (she said their names, but I summarized it here) for the number of ways to have Alice in the room.
 - **TN**: Kate has definitely clung onto the idea of holding one thing (person) constant. She is using Addition (or maybe Partition) thinking to find the number of groups involving Alice, then adding on the subsets involving the other people.
- Boris then explained that this problem reminded him of task 10: Cars problem. He said that in that problem he originally thought of the cars that each person could receive. He said that in this problem, he was thinking about the number of ways the rooms could receive them, but then he realized that it would be easier to think of the number of ways the people could go to the rooms.
 - **TN**: The difference is in the perspective. When he says "the number of ways the rooms could receive them," he is thinking about partitioning the children into two groups. He decided that it would be easier to think about which room Alice could go into, etc.
 - **MN**: Perhaps I really should add in an argument, or at least make a point of mentioning a prior students' idea to think from the perspective of the cars to the protocol for Task 10: Cars. That idea certainly seemed to help Boris here.
 - **ON**: Interestingly, both students in both problems (Cars and Grandma) began by trying to partition the items (Cars and People). However this question uses the word "place" and has a Distribution ICM whereas the Cars question is a Partition ICM.
- Boris explained that there were two rooms that the first person could go to. For each of those possibilities, there are 2 possibilities for where the second person

could go to. For each of those 4 possibilities, there were 2 more for the third person. And it will ultimately be 2^4 possibilities.

$$\begin{array}{cccc} 2 & \cdot & 2 & \cdot & 2 & \cdot & 2 & = & 16 \\ A & & B & & C & & D & & \end{array}$$

- **TN:** Boris is certainly engaging in top-down Standard Odometer thinking. It is clear that he is holding things constant and systematically varying others when he said “for each of those there are ...” Notice that he does not need to actually list the possibilities though.
- Kate actually listed possibilities for one room:

A	, AB,	AC,	AD,	ABC,	ABD,	ACD,	ABCD
B		BC	BD		BCD,		
C			DC				
D							

- **ON:** Kate missed Diana in the room by herself.
- **TN:** This is certainly Addition (or perhaps Partition) thinking based who is in the room. It is not clear which one it is because Kate didn’t mention the other subsets until she was actually counting them. However, it seems more like Addition because she is not adding on everything that has Bert, but just the remaining ones with Bert. Inside this way of thinking is the idea of holding something constant, adopted from the Odometer ways of thinking.
- Kate said that she got 15, which is one less than Boris got which made her think that she missed one.
- After the students examine the arguments again for about 2 minutes, Boris realized that Kate had missed listing Diana alone.
- At 0:14:04, I presented Annette’s tree-diagram. Kate said, at first, that she doesn’t even know what that means.
 - **TN:** Clearly, Kate was not envisioning tree-diagrams. Maybe this was why it was so mentally taxing for her to engage in that bottom-up approach.
- Boris said that Annette was just filling each spot with the different possibilities in each column. When I asked him to explain, he asked what the G and the U stand for. Kate said that it was ground floor and upstairs. Boris paused for a few seconds then.
 - **TN:** Boris’ pauses indicate that perhaps he was not envisioning tree-diagrams either. At least not in the same way Annette did. Even if he were not using G and U but another two distinct things, I would imagine that he would find an isomorphism between his argument and Annette’s. The fact that he couldn’t do so immediately might indicate that he was not envisioning a tree-diagram of any sort.
- Boris said that she was filling the requirement for each person. He said that the first person could either go to the ground floor or upstairs. Then the next person could go to the ground floor or the upper floor. He said that for those four possibilities, there are again 2 more possibilities for each of those.
- At this point, Kate said “oh, okay, so it’s just a graphic representation of what you were saying.” Ben agreed and said “yeah, with G’s and U’s.”

- I asked how they felt about the “graphic representation”. Boris said that it made sense once he thought about it. And Kate said “yeah, when you first look at it, you’re like ‘what is going on?’ but it makes sense once you get it though.”
- Boris said that the G’s and U’s threw him off. He would have preferred Room 1 and Room 2. Or using 0s and 1s.
 - **MN:** I think sticking with the Gs and Us would probably be best instead of introducing numbers (and A and B wouldn’t work because of the names of the children). I want the diagram to match the problem and think that introducing digits in the problem could be confusing. I would like to avoid confusion about whether the digits represent the rooms or represent numbers.
 - **MN:** Maybe it would be better to say “downstairs” and “upstairs” – might be more natural to native English speakers since that is typically how we say it here.
- He summarized the tree diagram by saying “it’s really just showing that there are two possibilities for every possibility that comes before it.”
- I asked if they liked the “web” thing that Annette did. Kate responded that it was very organized. Boris said that he would prefer it vertically instead of horizontally. Kate gave the partial tree-diagram below as an example. Boris could not explain why he would prefer it vertically except that he thinks it looks nicer vertically and would be easier to follow.

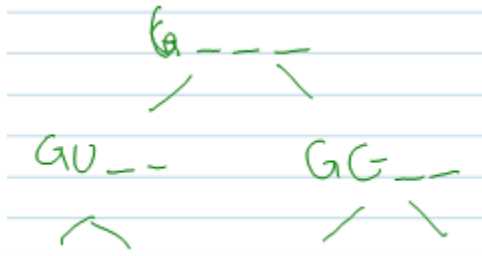

2) 0:17:39 – 0:25:05 Task 12: Lotto Numbers, Bat 11, S

- **Task:**
 - **Situation:** In a box there are four numbered marbles (with the digits 2, 4, 7, and 9). We choose one of the marbles and note down its number. Then we put the marble back in the box. We repeat the process until we form a three-digit number, our Lotto number.
 - **Question:** How many different Lotto numbers is it possible to obtain?
- Boris was immediately ready to answer the question, but Kate needed a few seconds to think. At first she said that she could talk about it but she doesn’t have very well-formed thoughts. A few seconds later she said “oh” and began her argument.
- She said that she remembered Boris’ method for doing to Fraternities problem and created 3 slots. She said that there were 4 possibilities for the first digit, 4 for the second and 4 for the third so it’s a total of 4^3 .
 - **TN:** It’s not clear if Kate is engaging in Standard Odometer thinking. At this point, it is likely, however. If she is engaging in Odometer thinking, then it is Standard because she refers to the first, second and third digits in order.

However, unlike Boris above, she doesn't say "for each one of those" as part of her argument. It's possible that this is implicit in her argument, or it is possible she's simply working through a process.

- **MN:** I could have asked why she was multiplying but it is most likely, given her responses in the past, she would have referred to holding something constant in the first position, etc. I think the students were getting tired of answering the "why multiplication question" when their answer was always the same. Also, even though she might discuss elements of the solution set in her explanation for why she is multiplying, that does not necessarily indicate that she was thinking about it before.
- Kate's slots are below:

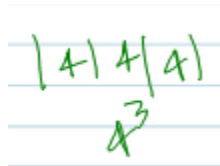

- **ON:** Kate is using the idea of slots, but she is not simply mimicking Boris' slots in the previous problem, her way of drawing them is different. This indicates that she has constructed slots for herself.
- Kate said that originally she was thinking about it in her own, complicated way where she would hold things constant and make lists, but then she remembered Boris' way was easier.
- I asked how her way compared with the way she ended up doing it. She said "well, it's basically the same thing, as we discovered last [...session...] but this is just a kind or more simple way of thinking about it."
 - **TN:** This seems to indicate that Kate knows that she is holding things constant and supports my idea above that she would have explained her multiplication in terms of holding things constant, as she has done for almost all of the other problems. It seems as if the multiplication she did is a way to encapsulate the top-down "holding something constant" idea.
- At 0:20:28, I provided Toni's tree diagram with blanks. I told the students that Toni gave the answer of 4^3 as well. Boris said that Toni's solution was just a visual representation to indicate that there are four possibilities for every possibility that comes before.
 - **TN:** I think he means that for each of the options for the first slot, there are 4 possibilities for the second, etc.
- Kate said that Toni made a mistake. She said that Toni forgot that the order of the numbers mattered. She said that she assumed that's what she meant when she left the blank boxes.
 - **TN:** Kate seemed to believe that Toni left the boxes blank because she was engaging in Deletion thinking. It seems as if Kate thought that the empty boxes are because that element had been counted already (assuming we are talking combinations not arrangements as Kate indicated that Toni seemed to be doing).
- Kate said that the way she would do it would be to fill all of them in, the way Annette did. She said "that's perfectly fine if you do it for all four of the graph

- things with the first digit. With all of the first digits. I'm pretty sure you'd be fine and you'd end up with the right answer. But um, she didn't."
- When I reminded Kate that Toni said that the answer was 64, she said "oh." A few seconds later she asked "Did she just not fill out the rest of them, and just assume that that would be the number of...that it didn't matter what the numbers *were*, she just..."
 - I responded that what was shown was what Toni gave me when she told me what the answer was and asked what the students thought. Boris said that she was just indicating the pattern. Kate immediately agreed.
 - I asked the students what would go in a couple of blanks in both the second and third levels in the different tree diagrams and they immediately responded, which indicates that they understood Toni's diagram and had made it their own.
 - I asked the students to contrast Toni's way with Annette's way in the previous problem. Boris thought that Toni's method saved time. He said that they know that they have the same number of possibilities when 2 is the first digit as they do when 9 is the first digit, so they don't really need to fill out all the boxes.
 - I then asked them to compare Toni's method with their own solution. Kate said "She just did what my first impulse was to do, which was to hold one thing steady and then change the second number. She just, um, whereas I would have done it as a big list of things, she did it graphically."
 - Boris added that in the process of doing "this" [the tree-diagram] she would have realized that it was "that" [4^3]. He said that since she said that the answer was 4 cubed, he imagined that she didn't actually count all of the elements, but realized that that was what the pattern was by doing this [tree diagram].
 - Kate said that Toni probably said that it was 16 times 4 because there were 16 "there" [one tree] times 4 [4 trees]. But she said "okay" when I told her that Toni's answer was 4^3 .

3) 0:25:05 – 0:32:36 Task 13: Committee 2, Bat 13, S

- Task:
 - Situation: A club needs a three member committee (president, treasurer, and secretary), and has 4 candidates (Arthur, Ben, Charles, and David).
 - Question: How many different committees could be selected?
- The students pointed out that in the previous Committee problem, it specified that the same person couldn't hold both, but this one doesn't specify.
- Kate also said that since the problem doesn't specify, she's not sure if the order of who is president, treasurer or secretary would matter.
- They decided that the same person could not hold both positions and that the order of the positions did matter.
- Boris said that he thinks there would be 24 different ways. He said "For the first position, I guess it doesn't matter which position you fill first, if it were president, there are 4 different people who could be president. Then for the next position there are 3 people that can be elected for each of those four possibilities. So that's

12 for the first two, and then for each of those 12 possibilities, there are 2 more possibilities for the last position. So we have $4 \times 3 \times 2$.

- Kate said that was exactly how she thought of it.
- I asked the students to graphically represent it the way Toni and Annette had.
- Kate provided the tree diagram for if Arthur was president and said “and then you’d do that for the rest.” I asked her what would come next. She added to the diagram to get what is below. She didn’t bother filling out the full tree diagram and Boris said that they would just leave the blanks and know that they would be filled. Kate agreed.

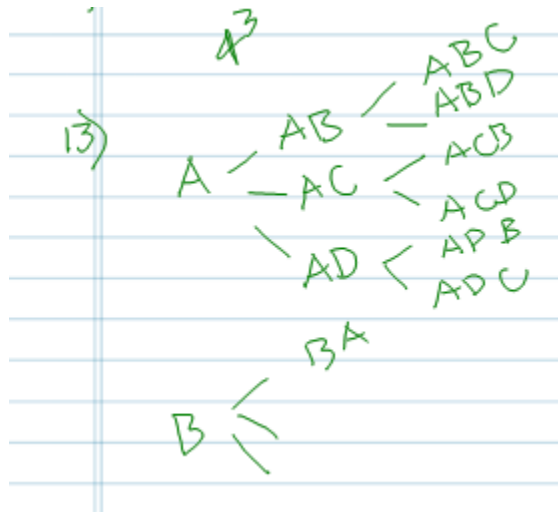

- **ON**: The 4^3 above is from the previous problem.
 - **MN**: Perhaps I should have provided Walter’s argument and then asked them to visually represent theirs for contrasting purposes.
 - At 0:30:03, I presented Walter’s argument and told them that Walter also said that the answer was $4 \times 3 \times 2 = 24$. Within 15 seconds, Kate said “so instead of focusing on a position, Walter is focusing on a person. So instead of saying ‘these are the people who could be president’, he was saying ‘these are the positions Arthur could fill.’” When I asked what those positions were, Kate said “president, secretary, treasurer, or none.”
 - Boris said that he didn’t have anything to add to that. I asked him to interpret the second tree diagram and he explained that there were 6 different ways for Arthur to hold the second position.
 - I asked them to compare Walter’s argument with their own. Boris said that they were looking at it as the number of ways a position could be filled instead of the number of ways that a person could hold a position. The students both said that they liked their way better.
- 4) 0:32:36 – 1:09:19 Task 14: Letters abcdef
- Task:

- Situation: Suppose we have the letters a,b,c,d,e,f and we are forming three-letter strings of letters (“words”) from these letters.
- Questions: How many 3-letters “words” can be formed from these letters if
 - Repetition of letters is not allowed
 - Repetition of letters is not allowed and the letter “d” must be used.
 - Repetition of letters is not allowed and either the letter “d” must be used or the letter “a” must be used.
 - Repetition of letters is allowed
 - Repetition of letters is allowed and the letter “d” must be used.
- The students agree that the order of the letters in the word matters.
- The students agreed that the answer to the first problem (repetition not allowed) is $6 \times 5 \times 4$. Kate explained that she was using the same idea she used in task 12. She said that there were 6 options for the first letter. For each of those options, there are 5 options for the second letter, because we can’t repeat the first letter. Again for each of those options, there are 4 options for the third letter because the two letters already used can’t be repeated. So there are $6 \times 5 \times 4$ possibilities.
 - **TN:** Kate seems to be clearly engaging in Standard Odometer thinking here. This is clear from her language “for each of those options, there are...” She is holding things constant in the first position then the second and then the third.
- Boris agreed with her and said that was how he was thinking about it.
- At 0:36:38, the students share their initial thoughts about question 2. Boris said that since d had to be used, we are really only filling 2 spots because d had to be in one of the 3 spots. He said that they could choose between 5 letters for the first spot and 4 for the second. He concluded that the answer would be 20.
- Kate said that that was what she was doing. When I asked whether she also got 20, she said that she had been holding d constant in different positions. She said that if d were in the first position, there would 5 options for the second letter and 4 for the third so it would be 5×4 ways. She said that when d was the second letter there would be another 5×4 and when d was the third, another 5×4 . She concluded that it would then be $5 \times 4 \times 3$ ways.
 - **TN:** This seems to be indicative of top-down Wacky Odometer thinking. She is holding the d constant in different positions and varying the others (by referring to the number of ways to fill the second and third slots). It could be Addition thinking, but the fact that she multiplied instead of summing $5 \times 4 + 5 \times 4 + 5 \times 4$ seems to indicate that she is really engaging in Wacky Odometer thinking instead. Also, she said in the beginning that she was holding d constant in different positions.
- Boris said that Kate’s argument was “more right” than his own. He said that he didn’t take into account the d. He said that he needed to “take into account in how

many ways the third slot [with the d] can fit into the two slots”. He said that for each of the 20 ways to fill 2 slots there are 3 different ways, so there are a total of 60.

- **TN:** This seems almost like what could be called a bottom-up approach to Wacky Odometer thinking. Speaking in terms of tree-diagrams, we could say that he is considering the leaves of one tree. And then he is figuring out the number of trees (by considering where the d could go in relation to the 2 slots already filled). If he were creating tree-diagrams, it would be organized in the same fashion that Kate’s would be, but the order of steps in the construction of them would be different.
- **TN:** Alternatively, this is similar to what Abromovich and Pieper (1996) refer to as recursive thinking about permutations. It’s like the argument driven by what I called “Insertion” thinking that I have for the Table problem in II2. I had not had empirical evidence for students engaging in insertion thinking before though. In this case, if we think in terms of tree diagrams, he is organizing the tree diagram as 20 trees with 3 leaves each...
- **Musing:** If we visually represent it as a complete bipartite graph with 3 options on one side (d, d, and d) and the 20 options on the other, then depending on which side we take as the root, we can split it into 2 different tree diagrams – one for bottom-up wacky odometer thinking and the other for insertion thinking. Is there a difference then?
- At 0:39:07, we proceeded to the third question (repetition not allowed and either a or d but not both must be used).
- Boris said that if a or d goes into the first spot, then there would be 2 possibilities for the first spot. Then for the second spot there would be 5 possibilities and then 4 possibilities for the last spot. He said that there would be 3 times that many because “just like in the last one,” a or d could be in the second or third spots.
 - **TN:** This seems indicative of top-down Wacky Odometer thinking. He is first considering one way for a or d to be, and then attempting to vary the other slots before changing the position for a or d.
 - **TN:** By saying “just like in the last one”, it indicates that he is thinking about this question in the same way that he thought of the last one. Since it seems as if he’s engaging in Wacky Odometer thinking here, it is possible that he was engaging in a form of Wacky Odometer in the previous question and does not see a difference between top-down and bottom-up approaches.
 - **ON:** Boris was actually overcounting by quite a bit.
- Kate said that she was doing pretty much the same thing she was doing for part b. She said that she was doing it separately for d and a.
 - **TN:** This seems indicative of Partition thinking – she is splitting the solution set into those which have d and those which have a.

- She said that if d were in the first spot, there would be 4 options for the second spot, because it can't be d again and it can't be a. She said that it would be the same if d were second or third, so we'd have to multiply that number by 3.
 - **TN:** This sounds like Wacky Odometer thinking. She is holding d constant in different positions and varying the others before changing the position of d.
- She continued on to say that we needed to multiply by 2 because it is the same set of numbers for when a is used.
 - **TN:** sounds like she has found a bijection between the subset involving d's and the subset involving a's and realized that they would have the same size.
- Kate found her answer to be $4 \cdot 3 \cdot 3 \cdot 2 = 72$. Boris wrote this down. He said that his answer was $2 \cdot 5 \cdot 4 \cdot 3 = 120$. He admitted that he wasn't really listening to what Kate was saying because he was trying to write down the problem in the notebook. After Kate explained her argument, Boris said that he was confused about why "this number" was 4. Kate started to use slots to explain. When she said "you can't use d and you can't use a," Boris asked why we couldn't use a. She explained that you couldn't use both and Boris reread the question and agreed with her argument after she re-explained it using the writing below. Her argument was essentially the same as before.

$$\begin{array}{l}
 \cancel{4} \cdot \cancel{3} \cdot 3 \cdot 2 = 72 \\
 2 \cdot 5 \cdot 4 \cdot 3 = 120
 \end{array}$$

- Boris claimed that he wasn't paying attention to the fact that you couldn't use both a and d.
- I asked what the answer would be if they could use both a and d. Kate said that the 4's and 3's would change to 5's and 4's, and they would end up with Boris' answer.
- I pointed out that the answer to a previous problem about repetition of letters not allowed was also 120.
- Boris said that this would indicate that all of the possibilities have a or d or both, but this is not true.
- The students pause for about 30 seconds before Kate said that their argument still made sense to her. She said that she was looking at both problems (the first question and this question) to find a flaw.
 - **MN:** I was about to direct the students towards thinking about the elements of the solution set so that they could find something that was being over-counted,

but decided to come back to this after they saw the overcounting argument and the deletion argument for the fifth problem.

- At 0:48:19 we moved on to the next question (repetition is allowed). The students immediately said that it was 6^3 . Boris explained that there were 6 options for the first letter, for each of those, 6 for the second and for each of those, 6 for the third. Kate agreed and we moved on.
- At 0:48:55, I presented the fifth question (repetition is allowed and d must be used). After taking a few seconds to think about the question, Kate said that she was moving the d around. If d were in the first place, there would be 6 possibilities for the second, and 6 for the third. She said that we needed to multiply by 3 because d can be in 3 places.
 - **TN:** This seems to be the same type of thinking Boris engaged in for the modification of the third problem. It is Wacky Odometer thinking since the d is changing placed and being held constant for a little while.
- Boris agreed with her. I provided the students with Oscar's argument (overcounting – similar to the students' argument) and Carrie's argument (driven by deletion).
- The student both said that Carrie's argument seemed pretty good. At my prompting, they realized that Carrie did not get 108 like they did.
- They take a while to look over the arguments. I asked them to explain Carrie's argument in their own words. Kate said that Carrie is just taking the total number of options and subtracting the ones that she doesn't want, which is everything that doesn't have a "d" in it. Kate said that this makes sense and that she has used that technique on problems in the past. She said "but I can't find where the error was made. I think it has something to do with the repetition of "d"s but ...[trails off]"
- Boris said that he's looking for a mistake in both arguments. He said that neither seemed like it had a mistake.
- After giving them a little while longer to think, I asked them to dig a little deeper into Carrie's argument. I asked how she got the $6 \times 6 \times 6$ part. Boris said that it was just what they had found from the previous question. I asked why it was 5^3 for the ones without d. Kate said that there were just 5 choices for each slot.
- I then asked them to look at their argument. I said "you said that if d is first, there are 6 times 6 options. Can you give me an example of that?" Boris said "dab or dad." I said "okay, so if d is second there are 6 times 6 ways to do that, and if d is third there are 6 times 6 ways. Can you give me an example where d is third?" Kate immediately said "OH! [...] if we repeat ds, we're going to get some of the same words [...] like dad."
- Boris then became worried about whether they were overcounting other letter combinations (other than just because of the ds) in both their own and in Carrie's argument. Kate said that she didn't see why it wouldn't be overcounting.

- Boris agreed, saying that “it seems like it would be [overcounted in Carrie’s]”. After pausing for about 10 seconds, he said “well, I guess you wouldn’t. Because the only thing we’re overcounting here [their original argument/Oscar’s argument] is the d’s. We’re not over-counting other letter combinations.” He said that they aren’t overcounting in Carrie’s argument.
- Kate was still confused. She said that she still doesn’t understand why Carrie is not making the same mistake. Boris explained that they were only overcounting the ds, not other letter combinations. He said that the combination bb wouldn’t be counted twice in that. He then said that he confused himself.
- Kate said “is it because it’s not considering d as like a distinct letter? Like it’s not d itself is the letter that we’re taking out, it’s just taking out the possibility of any one letter.”
- When I asked what she meant, she said “like for the set of numbers it’s subtracting, it’s not really taking into account the letter d, just taking out any letter.”
 - **TN:** Kate seems to have realized that 5^3 would be the answer to the number of “words” that do not include the letter x where $x \in \{a, b, c, d, e, f\}$ and this confuses her for some reason. Perhaps she is looking for a mistake in Carrie’s argument and just clings to this part, which made sense to her earlier?
- I asked her to explain where the 5^3 came from. In particular, I asked what the 5 options for the first slot would be. She immediately answered “a b c e f” and Boris said “all the letters except for d”.
- I asked her to explain her question again. She said “I don’t know. [pause] it was um [garbled because Boris is saying “I can’t figure out why –“ at the same time], yeah I couldn’t figure out why Carrie’s argument wouldn’t count d twice also.”
- Boris mumbled something and then said “like efe, it’s only going to count it once.”
- Kate said that Carrie’s argument made sense like 5 minutes ago and now it didn’t to her.
 - **MN:** this could be because the students had been at this for over an hour and had sat through my 266 class before that so they may have just needed a break.
- Boris said “okay, if we’re representing this visually...” I asked him to do so. He said “I don’t want to because there are so many.” He started making a tree diagram by listing possible first letters. He said “I was confused because I thought that things like efe would be counted twice, but they wouldn’t because e would only be counted once as a first letter and it would never be repeated. So it [efe] would only be at the end of this one diagram [tree with root e].” I asked if he were referring to the $6 \times 6 \times 6$ portion and he said yes.

- Kate said that they could then just take out all the ones that didn't have a "d" in them. I pointed out that they would need to be able to count how many they were taking out. The students then started filling out more of the tree-diagram with "a" as the root:

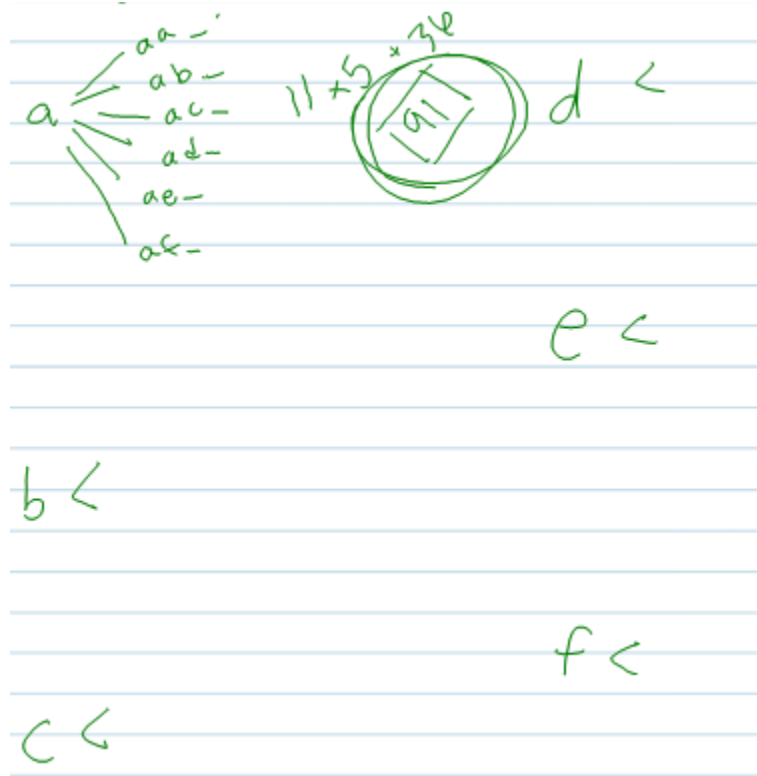

- Note: the calculations at the top had not yet been completed, but I can't crop them out...
- Kate said that they could just count up all the ones with d's. She said that there is one option with a "d" for "aa" [meaning that if aa were the first two spots, then aad is the only thing with a d possible]. She said that there would be 5 total options based on if the first letter were "a" and the second letter were a, b, c, e, f. She said "so 5 plus 6 [points to ad_]"
- Boris said that would be 11. Kate said it would be 11 times 5, but Boris said it would be 6. Kate pointed out that all of the ones with "d" as the first letter would need to be counted. They found the answer to be $11 \times 5 + 36$.
 - **TN:** This seems to be a mixture of Standard Odometer and Partition thinking. The solution set was partitioned based on first letter (and then grouped based on d vs non-d), but then things were held constant.
- I asked where the 11 came from and Kate explained that there would be 1 in the aa_, ab_, ac_, ae_, and af_, plus all of the ones in ad_. She said that it would be the same for different first letters, except for d, which would have 36.

- She said that she was trying to figure out if they would be repeating anything, but realized that everything was listed only once.
- I asked the students to compare their answer to Carrie's. Boris takes $125 + 91 = 216$ to confirm that they both got the same answers.
- I asked them to compare their Kate said that they eliminated the overcounting that was inherent in Oscar's argument.
- I asked the students to compare their solution to Carrie's. Boris said that it was similar, but they weren't waiting to take out the "non-d" possibilities. Kate said that instead of taking all of the possibilities and subtracting the ones they didn't want, they just "didn't count originally the ones we didn't want. We went through and counted all the ones with 'd's in them"
- I asked them for their preference in argument. Both said that they preferred Carrie's. Kate said that what they ended up doing is more logical to her so she might start doing that and then end up with Carrie's "if she had to do a bunch of problems like this". Boris said that he wouldn't have been able to do their method without "drawing all this out." But that Carrie's argument makes sense without really drawing anything.
 - **ON:** It'll be interesting to see how the students handle the third Sororities question in II2 then. Do they revert to their initial (Oscar) thinking? The way they ultimately did it? Or Carrie's deletion thinking?
- Kate said that if someone told them it was 11 times 5 plus 36, they would have no idea how they did that.
- I told the students that I would like the students to discuss the third question in their reflections instead of discussing whether the answer is 120 now.

5) 1:09:19 – 1:12:47 Task 15 – Boys and Perms, Bat 1, D

- Task:
 - Situation: Four boys are sent to the headmaster for cheating. They have to line up in a row outside the principal's room and wait to speak to the principal individually. Suppose the boys are called Andrew, Burt, Charles and Dan (A, B, C, D, for short). We want to write down all the possible orders in which they could line up.
 - Question. In how many ways can the boys line up?
- This is a permutation problem but the students treat it exactly as they have the previous problems. They find the answer to be $4 \times 3 \times 2 \times 1$ and Kate explained that for every option for the first spot, there are 3 options for the second spot. For those 12 options they had 2 options for the remaining ones.
 - **TN:** This seems to indicate Standard Odometer thinking because of their reference to slots and holding things constant in the first few positions.

APPENDIX C
INFORMATIONAL LETTER GIVEN TO STUDENTS

January 11, 2012

Dear Students,

As you know, I am a graduate student in the School of Mathematical and Statistical Sciences at Arizona State University. I am conducting a research study to provide some insight into the question: How do students develop their ways of thinking about the set of elements being counted as they progress through problems involving situations normatively taken to be combinatorial in nature?

I am inviting your participation in my study, which will involve meeting with me for 3 hour-long sessions individually and for 5 hour-long paired sessions. We will be working on enumerative combinatorics problems, but no prior experience with combinatorics is necessary. In fact, you may not participate if you have formal experience with combinatorics. The meetings will each consist of an exploratory teaching interview in which you will work through combinatorics problems, answering my questions as you proceed. You have the right not to answer any question, and to stop the interview at any time. You must participate in all 8 sessions in order to receive compensation. You must be 18 years or older to participate.

Your participation in this study is voluntary. If you choose not to participate or to withdraw from the study at any time, there will be no penalty. You will receive Honors credit for this course if you complete all 8 sessions and write reflections following each one. There are no foreseeable risks or discomforts to your participation.

Confidentiality will be maintained through the use of pseudonyms throughout the study. You may choose your own pseudonym. The results of this study may be used in reports, presentations, or publications but your name will not be used.

I would like to audio- and video-tape this interview. The interview will not be recorded without your permission. Please let me know if you do not want the interview to be taped; you also can change your mind after the interview starts, just let me know. The recordings will be made using a SmartPen© and with a webcam. I will keep the recordings on my computer for a period of 5 years for data analysis. Following this time, I will delete all of the files.

If you have any questions concerning the research study, please contact me at halani@mathpost.asu.edu. If you have any questions about your rights as a subject/participant in this research, or if you feel you have been placed at risk, you can contact the Chair of the Human Subjects Institutional Review Board, through the ASU Office of Research Integrity and Assurance, at (480) 965-6788. Please let me know if you wish to be part of the study.

Thank you,

Aviva Halani

APPENDIX D
HUMAN SUBJECTS APPROVAL FORM



Office of Research Integrity and Assurance

To: Kyeong Roh
PS

From:  Mark Roosa, Chair
Soc Beh IRB

Date: 12/06/2010

Committee Action: **Exemption Granted**

IRB Action Date: 12/06/2010

IRB Protocol #: 1011005765

Study Title: Students' Ways of Thinking about Combinatorics

The above-referenced protocol is considered exempt after review by the Institutional Review Board pursuant to Federal regulations, 45 CFR Part 46.101(b)(2) .

This part of the federal regulations requires that the information be recorded by investigators in such a manner that subjects cannot be identified, directly or through identifiers linked to the subjects. It is necessary that the information obtained not be such that if disclosed outside the research, it could reasonably place the subjects at risk of criminal or civil liability, or be damaging to the subjects' financial standing, employability, or reputation.

You should retain a copy of this letter for your records.

APPENDIX E
REFLECTION FORM

Reflection: MAT 266 Honors Contract

Reflect on the experience that you had in the session for your honors contract. You may answer the following questions for your reflection:

1. What was the topic dealt with in the special session? If you had any prior knowledge regarding the topics, please describe what you already knew about the topics.
2. What were the tasks or materials that the instructor designed for you? If you had any prior knowledge regarding the tasks or materials, please describe what you already about the tasks or materials.
3. What was the instructor's intention that you should learn from the tasks or materials? Explain how you can tell.
4. How did the instructor teach the topic? Was the instructors' approach similar to your previous instructors' approach? Or was it different (or, kind of new to you) from your previous instructors' approach? Please describe how it was similar or different.
5. What was (were) interesting to you about the tasks or materials? Why do you think so?
6. What was (were) the challenge that you faced with in understanding the tasks or materials? Why do you think so?