

Network Topology Optimization with Alternating Current Optimal Power Flow

by

Tejaswi Potluri

A Thesis Presented in Partial Fulfillment  
of the Requirements for the Degree  
Master of Science

Approved November 2011 by the  
Graduate Supervisory Committee:

Kory Hedman, Chair  
Vijay Vittal  
Gerald Heydt

ARIZONA STATE UNIVERSITY

December 2011

## ABSTRACT

The electric transmission grid is conventionally treated as a fixed asset and is operated around a single topology. Though several instances of switching transmission lines for corrective mechanism, congestion management, and minimization of losses can be found in literature, the idea of co-optimizing transmission with generation dispatch has not been widely investigated. Network topology optimization exploits the redundancies that are an integral part of the network to allow for improvement in dispatch efficiency. Although, the concept of a dispatchable network initially appears counterintuitive questioning the wisdom of switching transmission lines on a more regular basis, results obtained in the previous research on transmission switching with a Direct Current Optimal Power Flow (DCOPF) show significant cost reductions. This thesis on network topology optimization with ACOPF emphasizes the need for additional research in this area. It examines the performance of network topology optimization in an Alternating Current (AC) setting and its impact on various parameters like active power loss and voltages that are ignored in the DC setting. An ACOPF model, with binary variables representing the status of transmission lines incorporated into the formulation, is written in AMPL, a mathematical programming language and this optimization problem is solved using the solver KNITRO. ACOPF is a non-convex, nonlinear optimization problem, making it a very hard problem to solve. The introduction of binary variables makes ACOPF a mixed integer nonlinear programming problem, further increasing the complexity of the optimization problem. An iterative method of opening each transmission line individu-

ally before choosing the best solution has been proposed as a purely investigative approach to studying the impact of transmission switching with ACOPF. Economic savings of up to 6% achieved using this approach indicate the potential of this concept. In addition, a heuristic has been proposed to improve the computational efficiency of network topology optimization. This research also makes a comparative analysis between transmission switching in a DC setting and switching in an AC setting. Results presented in this thesis indicate significant economic savings achieved by controlled topology optimization, thereby reconfirming the need for further examination of this idea.

## ACKNOWLEDGMENTS

I would like to thank my advisor, Dr. Kory Hedman, for his valuable guidance and constant encouragement through every step of my graduate level studies. He has been a great source of inspiration, not only with his enthusiasm for the subject but also with his highly motivated nature. His dedication and responsibility towards his students have been of utmost value in shaping this thesis. He has provided me with opportunities to attend conferences and meetings, which have, to a very large extent, contributed towards my professional development.

I would also like to thank my committee members, Dr. Vijay Vittal and Dr. Gerald Heydt for their valuable time and suggestions.

I am grateful to my parents for their faith and utter confidence in me. I am thankful for the role they had in shaping my personality and helping me be the person that I am today. My heartfelt thanks goes to my brother, my roommates and my friends who have supported me through all my achievements and reinforced my confidence in times of need.

# TABLE OF CONTENTS

	Page
LIST OF TABLES.....	vii
LIST OF FIGURES.....	viii
CHAPTER	
1 INTRODUCTION.....	1
1.1 Overview.....	1
1.2 Research Focus.....	2
1.3 Summary of Chapters.....	4
2 LITERATURE REVIEW.....	6
2.1 Introduction.....	6
2.2 Legislative Mandates and National Directives.....	6
2.3 Loss Minimization.....	7
2.4 A Corrective Mechanism.....	8
2.5 Congestion Management Tool.....	9
2.6 Evolution of Network Topology Optimization.....	10
2.7 Optimal Transmission Switching with DCOPF.....	10
3 GENERATION DISPATCH AND OPTIMAL POWER FLOW.....	13
3.1 Generation Dispatch.....	13
3.2 Economic Dispatch.....	13
3.3 Optimal Power Flow.....	14
3.4 DCOPF.....	17
3.5 Network Topology Optimization.....	19

CHAPTER	Page
4 NETWORK TOPOLOGY OPTIMIZATION WITH ACOPF.....	20
4.1 Overview of Network Topology Optimization.....	20
4.2 Transmission Planning .....	21
4.3 Commercial Solvers for MINLP.....	21
4.4 Modeling of Transmission Switching.....	22
4.5 IEEE 118 Bus Test Case .....	25
4.6 Results and Analysis.....	25
4.7 Effect on Varying Loads .....	28
4.8 Losses.....	32
4.9 Voltage.....	35
4.10 Summary.....	37
5 COMPARISONS BETWEEN DC AND AC TRANSMISSION SWITCHING .....	39
5.1 Overview of DC Optimal Transmission Switching.....	39
5.2 Network Topology Optimization with DCOPF.....	40
5.3 Results of DC Transmission Switching .....	41
5.4 Comparison Between AC and DC Switching.....	45
5.5 Conclusion .....	49
6 HEURISTICS FOR PRACTICAL APPLICATION .....	51
6.1 Introduction to Heuristic Techniques.....	51
6.2 Evolutionary and Genetic Algorithms .....	52
6.3 Application of Fuller’s Heuristic to AC Systems .....	53

CHAPTER	Page
6.4 Results .....	55
6.5 Conclusion .....	60
7 CONCLUSIONS .....	61
8 FUTURE RESEARCH .....	64
8.1 Overview .....	64
8.2 Transient Stability.....	64
8.3 Protective Devices/Relays .....	65
8.4 Circuit Breakers .....	65
8.5 Reliability.....	66
8.6 Heuristic Techniques .....	66
BIBLIOGRAPHY .....	68
APPENDIX	
A NOMENCLATURE.....	71

## LIST OF TABLES

Table	Page
4.1 Transmission switching results for IEEE 118 bus case .....	27
4.2 Results of switching at varying load levels for 118 bus test case .....	29
4.3 Results of switching for loads as a percentage of the actual load level .	31
5.1 Transmission lines to switch for $C=1$ and 2, varying load levels .....	44
5.2 Comparison of ACOPF performance with DC initial solutions .....	48
5.3 Comparison of DCOPF performance with AC initial solutions .....	49



## LIST OF FIGURES

Figure	Page
4.1 One line diagram of IEEE 118 bus test system with line 32 open .....	26
4.2 Graph showing economic savings gainst number of lines open .....	28
4.3 Graph representing percentage savings when 1 and 2 lines are opened	30
4.4 Graph showing cost savings against load levels in percentage .....	32
4.5 Graph showing real power losses and percentage savings against number of lines open in a 4519 MW 118 bus system .....	34
4.6 Graph showing real power losses and percentage savings against number of lines opened 4017 MW 118 bus system .....	34
4.7 Voltage profile of IEEE 118 bus test case with load at 4519 MW .....	36
4.8 Voltage profile of IEEE 118 bus test case with load at 4957 MW .....	36
5.1 Results of IEEE 118 bus case DCOPF with transmission switching ....	42
5.2 Network topology optimization with DCOPF at varying load levels ...	43
5.3 Comparison between AC and DC transmission switching for the IEEE 118 bus test case with load at 4519 MW .....	45
6.1 Flow chart of the heuristic with ACOPF .....	54
6.2 Heuristic performance with respect to brute force method for 1 line opened .....	56
6.3 Heuristic performance with respect to brute force method for 2 lines opened .....	56
6.4 Heuristic performance for load as a percentage of 4519 MW for 1 line open .....	57

Figure	Page
6.5 Heuristic comparison for varying load levels, one line open .....	59
6.6 Heuristic comparison for load levels as percentage of actual load, one line opened .....	59

## CHAPTER 1: INTRODUCTION

### 1.1 Overview

At the time when Nikola Tesla dreamed of commercial electricity, it was a luxury that was affordable only by the rich. Over a hundred years later, in the present scenario, electric energy is considered a necessity rather than a luxury. Continuous research and a willingness to apply new techniques help in keeping up with the demands on the electric grid. A reliable electric network aides the industrial and commercial development of a country. Consequently, there has been a national push to create a smarter, more reliable and flexible electric grid.

Traditionally, transmission lines are considered as static assets. The operator dispatches generation with an objective to minimize the total generation cost while satisfying all the system constraints. Although transmission switching is used today for maintenance purposes and as a corrective mechanism, the concept of incorporating transmission switching in day to day dispatch operations for economic benefit has not been examined to its maximum potential. The possibility of varying optimal network topologies for different operating conditions has not been vastly explored. It is known that the electric network has built-in redundancies to ensure reliable operation. However, all of these redundancies may not be required for every operating state. As the operating state of the grid changes, the redundancies needed to ensure the reliability of system change as well. Moreover, these redundancies may cause the grid to deviate from operating at its optimal topology. Therefore, it is beneficial to view transmission as a flexible asset since the

ability to switch transmission lines adds another layer of control in order to improve system operations, reliability, and market efficiency.

This research strives to validate the concept of transmission switching and examine the impact of incorporating network topology control in the Alternating Current Optimal Power Flow (ACOPF) problem. A comparative analysis between Direct Current (DC) and Alternating Current (AC) transmission switching is also performed.

## **1.2 Research Focus**

The primary aim of this research is to evaluate the concept of incorporating topology optimization in a traditional OPF problem. The objective of the OPF is to find a least cost generation dispatch solution while satisfying the constraints of the system. The ACOPF is a non-convex non-linear problem, which is difficult to solve using the present day commercial solvers. The state of a transmission line in the network (in service or out of service) is represented in the optimal power flow problem with a binary variable making the ACOPF a Mixed Integer Non Linear Programming (MINLP) problem, a far more difficult problem to solve. A common approach taken to overcome this problem is to use the linearized version of the AC nonlinear constraints with a linear objective. This creates a Linear Programming (LP) problem called the Direct Current Optimal Power Flow (DCOPF), and when transmission switching is incorporated, the DCOPF becomes a mixed integer programming (MIP) problem. This research analyzes the feasibility of transmission switching and the impact of switching on AC parameters like voltage, reactive power, and losses.

Furthermore, this research endeavors to study the impact of network topology optimization on the deregulated energy market structure. Studies have been performed to answer questions pertaining to how a dispatchable network affects the Locational Marginal Prices (LMP), Generation Revenue, Load Payment, and Congestion Rent. The changes in dispatch efficiency and social welfare with the incorporation of switching are examined.

In addition, a comparative analysis is performed between the DC transmission switching and AC transmission switching. The electric grid is primarily composed of transmission lines operating in the AC setting. The MINLP problem formed by the ACOPF formulation with binary variables makes it a very difficult nonlinear non convex problem to solve. Operators today perform DCOPF with unit commitment since unit commitment with AC is too difficult to solve. Then, the DC optimal solution is used as an initial solution to obtain an AC feasible solution. However, it is important to examine the effects of transmission switching on the AC transmission grid in terms of economic benefits, voltage, reactive power, and losses. This makes a study of transmission switching on an AC level a necessity to understand the concept of network topology optimization. At the same time, the practical application of transmission switching is currently limited to the DC level making an understanding of the commonalities and differences between AC and DC switching imperative.

As a final part of the research, a heuristic has been proposed to find a network topology that has significant economic saving within a reduced solution time. This thesis concludes with a discussion on future research.

### 1.3 Summary of Chapters

A literature review of past research done on transmission switching is presented in Chapter 2 of this thesis. The concept of transmission switching proposed for various reasons like corrective switching and congestion management, and the various techniques adopted are listed. A thorough examination of research done on co-optimization of transmission with generation dispatch on a DC level is also performed in the literature review.

Chapter 3 gives an overview of generation and economic dispatch along with the mathematical formulation of ACOPF. The linear approximation of ACOPF to DCOPF is discussed and a brief introduction to network topology optimization is provided.

Chapter 4 begins with an introduction to the research topic and explains the motivations behind proposing the concept of the dispatchable networks. The differences and similarities between transmission switching and transmission expansion are emphasized followed by a discussion on the difficulties in solving an MINLP. Modeling of ACOPF with transmission switching and the results of studies performed on an IEEE 118 bus test case are presented. The effect of network topology optimization with ACOPF on various AC parameters like voltage and losses are examined and the results of transmission switching at various load levels are also included.

As mentioned in the previous sections, there is a need to study the relationship between DC and AC transmission switching. This remains the primary motivation for Chapter 5. A comparison of results obtained by transmission

switching with both DCOPF and ACOPF performed on the same test case is presented. The inferences that can be made from this comparison are pointed out and several conclusions leading to a better understanding of transmission switching have been made.

Chapter 6 proposes a heuristic to overcome the major setback of AC transmission switching, i.e., the solution time. The results of the heuristic are presented and the solution time and accuracy of the heuristic results are compared against the original network topology optimization results obtained in Chapter 4. An attempt to address the general misconceptions of congestion on a transmission line has also been made with the aid of a new heuristic.

A summary of the results and various conclusions to this thesis are presented in Chapter 7 followed by a discussion on the future research prospects in the field of optimal transmission switching in Chapter 8.

## CHAPTER 2: LITERATURE REVIEW

### **2.1 Introduction**

The aim of this research is to study the impacts of topology optimization on the ACOPF, compare the ACOPF topology optimization problem to the DCOPF, and to examine potential solution techniques. A history and background on previous work done on transmission switching is presented in this chapter. A review of the origin of dispatchable networks and past research examining transmission switching on a DC level is provided. A list of contemporary industry practices related to switching of lines is also discussed.

### **2.2 Legislative Mandates and National Directives**

The increase in the importance of electric power calls for an urgent improvement in the technology of the electric grid. Reference [1] refers to a 50% increase in electricity consumption by 2030, which increases the stress on an already overworked network. A smarter grid not only improves the efficiency of the electric transmission and distribution systems but also ensures a secure and reliable power system. This research is in line with several national directives addressing this need for a smarter and more flexible grid.

The United States Energy Policy ACT (EPACT) of 2005 calls for advanced transmission technologies while the FERC order 890 encourages the improvements in economic operations of transmission grid. This thesis on “Network topology optimization with ACOPF” aims to address these national policies. It is also in accordance with the Energy Independence and Security Act (EISA), which was passed by the United States Congress and approved by the President in De-



ember 2007. Title XIII of EISA defines a smart grid and continues to “...establish a federal policy to modernize the electric utility transmission and distribution system...”. The intention of this research is to harness the control of transmission assets by the dynamic optimization of the grid and the co-optimization of transmission with generation, thereby encouraging a smarter, flexible, and more efficient electric network.

### **2.3 Loss Minimization**

There is a common misconception that when transmission lines are taken out of service, the losses in the system increase. However, in practice it cannot be proven whether the losses increase or decrease as the total network is re-dispatched once the topology is reconfigured. There have been several papers in the literature stating the use of topology reconfiguration as a means for loss reduction in the power network.

Reference [2] introduces a current injection based switching model, which is treated as an optimization problem to demonstrate the ability of switching to minimize losses. This concept is further explored by [3] and [4], which describe a piece-wise linear approximation to find the relation between real power losses and line flows. A linear MIP is used to demonstrate the decrease in losses. It is to be noted that this optimization problem has an objective to minimize losses as opposed to maximizing social welfare, which should be the true goal of the optimization problem.

This research also focuses on studying the impact of transmission switching on losses in the system and this is done by co-optimizing the topology with

generation, thereby studying the effect of losses with transmission switching while simultaneously ensuring maximized social welfare. As it will be shown in the results of the following chapters, the misconception that losses increase when transmission lines are switched will also be addressed.

## **2.4 A Corrective Mechanism**

Past research proposes transmission switching as a corrective mechanism to overcome network constraint violations like line overloads and voltage deviations. Reference [5] developed an algorithm for switching ranked transmission lines to alleviate system overloads in 1986. Reference [6] proposes a linear programming based optimization problem to relieve the system of undesirable conditions. A ranking methodology that places branch switching operations in order of their effectiveness to provide corrective actions is devised in this paper. These researches assume the generation dispatch to be fixed while topology optimization is applied. This assumption takes away from the benefit of co-optimizing the network with generation, thereby creating a more efficient grid.

Reference [7] presents a search mechanism combining  $N-1$  security analysis and optimal power flow. A heuristic that utilizes transmission switching as a corrective mechanism for contingencies is presented. However, this method does not generate the optimal solution due to the complexity of the optimization problem and works with a candidate set of switching actions. Reference [8] proposes a control strategy for short time stabilization using switching concepts. Though their simulations demonstrate the use of transmission switching for improvement of transient response of a system, this method relies on control strategy rather than

an optimization method. Reference [9] presents a practical implementation of the Corrective Switching Algorithm (CSA) for overload relief. This method is again based on a searching algorithm and a set of pre-selected candidate lines list. Also, generation is re-dispatched after the switching action instead of a simultaneous optimization of generation and transmission profiles.

Reference [10] is a review paper on the various switching techniques and practices available for helping with voltage violations and line overloads. It also addresses the practical issues with the application of corrective switching and differentiates between the various methods that have been suggested regarding this concept. Reference [11] puts forward an algorithm to find the best switching action to alleviate line overloads and voltage violations caused by system faults. This technique is based on fast decoupled power flow and has a limited iteration count for generating solutions faster. Reference [12] gives a feasible load flow study for base case and contingency cases using corrective switching methods. The technique proposed is based on constraint programming and a tree search method formulation.

## **2.5 Congestion Management Tool**

It has generally been assumed that taking transmission lines out of service increases the congestion in the system. This misconception has been proven wrong in this research. It cannot be assumed that congestion on the network increases or decreases, just as it cannot be assumed that losses must increase with the switching of transmission lines. Network topology optimization allows for a system re-dispatch, which makes it impossible to state the impact on congestion.

The concept of transmission switching as a tool for congestion management has been investigated by [13]. The proposed technique is based on both deterministic and genetic algorithms to reconfigure the system so as to minimize congestion in the network. Reference [14] devises a topology re-dispatch congestion management methodology. The expectation of increased congestion in the system due to high renewable penetration has been stated as the motivation for the improvement in congestion management techniques.

## **2.6 Evolution of Network Topology Optimization**

The concept of dispatchable networks was first introduced in [15]. Further research on the feasibility of network topology optimization was conducted in [16]. A mixed integer linear programming optimization problem was formulated to find the optimal generation dispatch when transmission line status is co-optimized with generation. An extension to this work is found in [17] where transmission switching with DCOPF was analyzed. The various aspects of this research are summarized in detail in the following section. Additional simulations to test the practicality of transmission switching and the various computational issues have been addressed in [18].

Thus, the concept of transmission switching has come to light in recent years and extensive research in this area is necessary to completely evaluate its potential and address any concerns related to network topology optimization.

## **2.7 Optimal Transmission Switching with DCOPF**

The progression of dispatchable networks has been discussed in the previous section. Extensive work on the co-optimization of network topology with

generation dispatch in a DCOPF model has been done in [17]. The impact of transmission switching on nodal prices, generation revenue and rent, load payment, and congestion rents is studied. Reference [19] examined the co-optimization of generation unit commitment with transmission system with  $N-1$  reliable DCOPF model. It was demonstrated that a system can comply with  $N-1$  standards within the assumptions of the model, in spite of having a different optimal unit commitment solution due to transmission switching.

One question that has yet to be answered is whether  $N-1$  reliability can be achieved when co-optimizing the topology with generation based on an ACOPF framework. Due to the computational complexities of the MINLP formed by network topology optimization using ACOPF, checking for reliability of the system on an AC level can be performed similar to the unit commitment problem. Unit commitment is performed on DCOPF and the solution is fixed to find an AC feasible power flow. Similar to this, an  $N-1$  reliable solution is found for DCOPF and the solution is fixed before solving for an AC feasible solution. Co-optimizing the system for reliability with network topology optimization makes it an extremely difficult problem for the present day commercial solvers to solve. However, previous academic research and industrial practices referenced in the above sections demonstrate the utilization of transmission switching for corrective mechanisms and congestion management, thereby improving reliability of the network. Therefore, such previous research suggests that network topology optimization can be formulated in such a way so as to not violate  $N-1$  reliability standards.

Reference [20] continues on to propose a concept called Just-in-time transmission to further ensure the reliability of a system when topology optimization is applied. Reference [21] addresses the concerns that transmission switching might lead to revenue inadequacy. The structure and principles that the current market system is based on has been developed in tandem with the way energy markets have been operating for the past decade. With new technologies, there is a need to review these principles. However, this paper on revenue adequacy illustrates that the concept of dispatchable networks can be modified to maximize social welfare while warranting revenue adequacy, if desired.

All previous work presented in this chapter justifies the need for additional exhaustive research to be done in the field of network topology optimization. This provides the necessary motivation for the current research on transmission switching with ACOPF. This work attempts to put the idea of harnessing the control of a transmission system in perspective and explores the potential of adding an additional layer of control to the electric grid in order to further the steps taken towards creating the much anticipated smart grid.

## CHAPTER 3: GENERATION DISPATCH AND OPTIMAL POWER FLOW

### **3.1 Generation Dispatch**

The electric industry is comprised of four major components: Generation, Transmission, Distribution, and the Load. The traditional operation of the grid has the operator dispatching the generation at minimum generation cost to meet the load while keeping the remaining assets fixed. Modern technologies aim to create flexibility in all components of the grid, resulting in a smarter and more efficient electric network. Capturing the flexibility in load, e.g., modeling of deferrable load, would create a more flexible and smarter grid. Harnessing the flexibility in the network topology e.g., FACTS devices and transmission, would further add an additional layer of control on the transmission side.

### **3.2 Economic Dispatch**

Economic dispatch is an optimization problem that finds the minimum generation cost for generation dispatch in order to meet load on the system while adhering to the minimum and maximum generator capacity constraints. As none of the network flow constraints are taken into consideration this is also called unconstrained economic dispatch. It sets a lower bound on the optimal power flow problem. Economic dispatch is a sub problem of unit commitment. Unit commitment models a generator's ON or OFF status, its minimum and maximum capacity, ramp rates, up and down time constraints, no-load and startup costs as well as its available reserve.

### 3.3 Optimal Power Flow

The majority of the transmission grid operates based on an AC setting. The ACOPF problem represents the transmission of power from the point of generation to the load through the transmission lines at the optimal generation cost. These flows on the transmission lines are governed by Kirchhoff's laws and ACOPF takes into consideration these laws in the form of constraints.

The ACOPF formulation is shown below:

$$\text{Minimize: } \sum_g c_g P_g \quad (3.1)$$

subject to:

$$-S_k^2 \leq (P_{kmn}^2 + Q_{kmn}^2) \leq S_k^2, \quad \forall k \quad (3.2)$$

$$-S_k^2 \leq (P_{knm}^2 + Q_{knm}^2) \leq S_k^2, \quad \forall k \quad (3.3)$$

$$V_m^2 G_k + V_m^2 G_{mk} - V_m V_n (G_k \cos(\theta_m - \theta_n) + B_k \sin(\theta_m - \theta_n)) - P_{kmn} = 0, \quad \forall k \quad (3.4)$$

$$V_n^2 G_k + V_n^2 G_{nk} - V_n V_m (G_k \cos(\theta_n - \theta_m) + B_k \sin(\theta_n - \theta_m)) - P_{knm} = 0, \quad \forall k \quad (3.5)$$

$$Q_{kmn} + V_m^2 B_k + V_m^2 B_{mk} + V_m V_n (G_k \sin(\theta_m - \theta_n) - B_k \cos(\theta_m - \theta_n)) = 0, \quad \forall k \quad (3.6)$$

$$Q_{knm} + V_n^2 B_k + V_n^2 B_{nk} + V_n V_m (G_k \sin(\theta_n - \theta_m) - B_k \cos(\theta_n - \theta_m)) = 0, \quad \forall k \quad (3.7)$$

$$\sum_{\substack{k(.,n) \\ k(n.,)}} P_{knm} + \sum_{\substack{k(n.,) \\ k(.,n)}} P_{kmn} - \sum_{g(n)} P_g + P_{dn} = 0, \quad \forall n \quad (3.8)$$

$$\sum_{\substack{k(.,n) \\ k(n.,)}} Q_{knm} + \sum_{\substack{k(n.,) \\ k(.,n)}} Q_{kmn} - \sum_{g(n)} Q_g + Q_{dn} = 0, \quad \forall n \quad (3.9)$$

$$P_{min} \leq P_g \leq P_{max}, \quad \forall g \quad (3.10)$$

$$Q_{min} \leq Q_g \leq Q_{max}, \quad \forall g \quad (3.11)$$

$$-\theta_{max} \leq \theta_n - \theta_m \leq \theta_{max}, \quad \forall k \quad (3.12)$$

$$V_{min} \leq V_n \leq V_{max}, \quad \forall n \quad (3.13)$$



The objective of the ACOPF problem is to maximize the total social welfare. However, with the assumption that load is perfectly inelastic, minimizing the total generation cost is the same as maximizing the total social welfare. Hence, the objective (3.1) is to minimize the total generation cost wherein the generator cost curve is assumed to be linear or approximated by piecewise linear cost curve.

Constraint (3.2) and (3.3) represent the capacity constraints on the transmission line  $k$  in both directions. The power flows on the transmission lines are considered in both the directions to calculate the losses involved in transmission.

Equation (3.4) represents the real power flow on transmission line  $k$  from node  $m$  to node  $n$ . Constraint (3.5) represents the real power flow on line  $k$  from node  $n$  to node  $m$ . Similarly, (3.6) and (3.7) reflect the reactive power flow on line  $k$  in both the directions. The terms  $G_{mk}$  and  $B_{mk}$  in the above constraints represent the shunt conductance and susceptance respectively, at bus  $m$  of the transmission line  $k$  and the terms  $G_{nk}$  and  $B_{nk}$  represent the shunt conductance and susceptance respectively, at bus  $n$  of the transmission line  $k$ .

Constraints (3.8) and (3.9) are the node balance or power balance equations, which characterize the law of conservation of energy. The node balance equations specify that the power flow into a bus must equal the flow out of the bus. The absolute value of the sum of line flows in both the directions represents the line flow loss and is considered as a withdrawal. The load consumption on a bus is also considered as a withdrawal whereas the sum of generation is an injection at the bus. Hence, the node balance equation (3.8) ensures that the total real

power injected into a bus equals the real power withdrawal at that bus and (3.9) applies to the reactive power conservation at a particular bus.

Constraints (3.10) and (3.11) reflect the real and reactive generation capacity on the generator respectively. It is to be noted that this is a linear representation of the generator's actual restriction on its real and reactive power governed by its  $P$ - $Q$  curve. Since unit commitment on an AC level is a very hard problem to solve, it is assumed that the generators are online and the minimum real power generation capacity on every generator is assumed to be at zero though this is not necessarily true in a practical test case.

Equation (3.12) restricts the angle difference between any two buses connected by a transmission line. If the angle difference between the buses is too high it may lead to a system collapse; hence, it is imperative that the angle difference be constrained.

Constraint (3.13) sets limits on the voltage at each bus. This constraint is important to ensure voltage stability on the system as both over voltage and under voltage have serious repercussions on the stability of the system.

It is seen from the above formulation that ACOPF is a nonlinear non convex optimization problem and some of the constraints have trigonometric terms. This makes ACOPF a very difficult problem to solve. To deal with this difficulty, certain assumptions are made to linearize the AC power flow problem creating a linear programming problem called the DCOPF.

### 3.4 DCOPF

The non-convexity of the constraints in an AC power flow problem makes it a very hard problem to solve and some of the present day NLP commercial solvers cannot handle the complexity of an ACOPF. Consequently, several approximations are made to linearize the ACOPF, which result in the DCOPF.

In a DCOPF, the reactive power component is ignored and the resistance is assumed to be such that  $r_k \ll x_k$ , or basically assumed to be zero. This assumption makes the DC model lossless and eliminates the need for representing the line flow in both directions. Hence, the line flow variables,  $P_{kmn}$  and  $P_{knn}$  in the line flow rating, power flow constraints, and the node balance equations, (3.2)-(3.9), are replaced by a single line flow variable  $P_k$ .

In addition, the voltage magnitudes are assumed to be 1.0 p.u. Generally, the voltage at a bus is very close to 1.0 p.u and such an assumption eliminates the non-linearity caused by the product of voltage variables with other variables in the constraints (3.4)-(3.7). Furthermore, the angle difference between any two buses connected by a transmission line is assumed to be small. This assumption can be used to simplify the trigonometric terms in (3.4)-(3.7). The small angle approximation in trigonometry states that the cosine of a small angle is approximated as 1 and the sine of a small angle is the angle itself (in radians).

Upon application of these assumptions, the linear DCOPF formulation is as shown below:

$$\text{Minimize: } \sum_g c_g P_g \tag{3.14}$$

subject to:

$$-P_{kmax} \leq P_k \leq P_{kmax}, \forall k \quad (3.15)$$

$$P_k - B_k(\theta_n - \theta_m) = 0, \forall k \quad (3.16)$$

$$\sum_{k(n,..)} P_k - \sum_{k(.,n)} P_k + \sum_{g(n)} P_g - P_{dn} = 0, \forall n \quad (3.17)$$

$$P_{min} \leq P_g \leq P_{max}, \forall g \quad (3.18)$$

$$-\theta_{max} \leq \theta_n - \theta_m \leq \theta_{max}, \forall n \quad (3.19)$$

It is seen from the above formulation that the DCOPF is a linear programming problem, which is easier and faster to solve. Also, the ACOPF by itself is a difficult problem to solve and the addition of a unit commitment problem would make it an even harder problem to solve. For these reasons, system operators run a DCOPF with unit commitment to find the optimal generation dispatch. After an optimal solution in the DC is obtained, this optimal solution is used as an initial solution to run an ACOPF and a local optimal solution to the ACOPF is found. If a local optimum is not reached within a set time frame, an AC feasible solution generated by the solver is used.

However, DCOPF is an approximation to the ACOPF and, hence, does not represent the actual electric system. Several parameters like reactive power, losses, etc., are neglected in the DC model and remedies such as proxy limits have been proposed in the literature to deal with these shortcomings of DCOPF.

DCOPF can also be formulated using Power Transfer Distribution Factors (PTDFs) to represent the network flow constraints. However, PTDFs are dependent on the network topology and need to be recalculated for every change in to-

pology. This increases the computational complexity of the DCOPF network topology optimization problem. Furthermore, PTDF calculations do not take parameters such as reactive power, losses and voltage into consideration. For this reason, formulating transmission switching with ACOPF model using PTDFs might result in inaccuracies in addition to increasing the complexity of the optimization problem itself. Hence, the above proposed formulations are used for DCOPF and ACOPF transmission switching computation throughout this thesis.

### **3.5 Network Topology Optimization**

Previous work on DC transmission switching can be found in the literature. This research extends upon DC network topology optimization and aims to validate the concept of dispatchable networks from an AC point of view. This thesis proceeds to show that co-optimizing the network along with generation can lead to substantial economic savings. Details such as the frequency of performing transmission switching in practice: real time, day ahead or monthly, transient stability, and market impacts of transmission switching are examined.

### 4.1 Overview of Network Topology Optimization

The electric grid is built with redundancies in order to account for contingencies and ensure reliable operations. While redundancies are necessary for reliability, not all the transmission lines are needed at every operating state. The state of the system changes with variations in load and generation. Since the optimal network topology configuration changes with the operating state, the use of a static network topology is inefficient. Therefore, co-optimizing the network topology with generation guarantees a solution that is either better than or at least as good as the previous optimal solution since network topology optimization creates a superset of feasible solutions.

It is shown in further chapters that incorporating transmission switching in the traditional OPF leads to significant savings in generation cost. Section 4.2 distinguishes between transmission planning and transmission switching. Section 4.3 discusses the unavailability of commercial solvers to solve the difficult MINLP problems like ACOPF with transmission switching and the actions taken to overcome these solver issues in this research. The modeling of a binary variable to represent the switching on and off of transmission lines in a network is explained in Section 4.4. Sections 4.5 and 4.6 present and analyze the results of transmission switching when incorporated with ACOPF modeled in an IEEE 118 bus test system. The effect of transmission switching on varying load levels is discussed and the results are presented in Section 4.7. The remaining sections explore the impact of dispatchable networks on losses and voltage.

## **4.2 Transmission Planning**

It is important to understand the differences between short term network topology optimization and transmission planning. It may be assumed that optimal transmission switching is only beneficial with a poorly planned network. Transmission planning is a long term optimization problem that endeavors to find an optimal topology for the electric grid over a large period of time. The evaluation criterion is based on either reliability or economics. However, since the load and generation of the network change from period to period, not all transmission lines may be required at all periods of operation. While transmission planning is a long term problem that seeks to find the best line over multiple periods, optimal transmission switching determines the optimal network configuration for a particular operating state. As such, the optimal network topology in the long run need not be the same as the optimal topology for specific operating states. Therefore, the flexibility of the network topology should be considered in the short term in order to improve system operations and reliability.

## **4.3 Commercial solvers for MINLP**

ACOPF is a very difficult nonlinear non-convex problem with trigonometric functions in its constraints. It is a very hard problem to solve and is highly time consuming. Incorporating transmission switching in ACOPF involves modeling of a binary variable, which makes the transmission switching ACOPF a MINLP problem, an even more complex problem to be solved. Modern day solvers are largely capable of handling mixed integer linear programming problems. There are commercial solvers that can handle some of the non-convex

nonlinear problem but do not always guarantee a good solution. However, these solvers do not have the capability to deal with a MINLP problem. The unavailability of solvers that can deal with the complexity of network topology optimization on a large scale in an AC setting makes the concept of transmission switching very difficult.

A brute force method of solving the ACOPF while each of the transmission lines is switched out individually is applied to an IEEE 118 bus system and the results are presented in the following chapters. This complete enumeration method is proposed as an investigative methodology to analyze AC network topology optimization as opposed to being suggested as a solution technique to be used for practical application of transmission switching. This method is primarily employed as a means to run comparative analysis between AC transmission switching and DC switching transmission switching, as discussed in the following chapters. This method makes the MINLP into a nonlinear programming problem, thus overcoming the solver issue as well. This technique, however, has the drawback of a high solution time. A heuristic has been proposed in the later chapters to reduce the computational time. The results obtained from this exhaustive search method are also used as a measure against the efficiency of the heuristic.

#### **4.4 Modeling of Transmission Switching**

Transmission switching is represented in an ACOPF by a binary variable  $z_k$  indicating the line is in service or out of service. If  $z_k=1$ , it represents the line is closed and in service;  $z_k=0$  indicates that the line is open and out of service. This binary variable ensures that line flow constraints and line flow variables are zero



for the corresponding opened line in the ACOPF formulation. The new ACOPF formulation reflecting the state of the transmission line is defined below.

$$\text{Minimize: } \sum_g c_g P_g \quad (4.1)$$

subject to:

$$-z_k S_k^2 \leq (P_{kmm}^2 + Q_{kmm}^2) \leq z_k S_k^2, \forall k \quad (4.2)$$

$$-z_k S_k^2 \leq (P_{knn}^2 + Q_{knn}^2) \leq z_k S_k^2, \forall k \quad (4.3)$$

$$z_k (V_m^2 G_k + V_m^2 G_{mk} - V_m V_n (G_k \cos(\theta_m - \theta_n) + B_k \sin(\theta_m - \theta_n)) - P_{kmm}) = 0, \forall k \quad (4.4)$$

$$z_k (V_n^2 G_k + V_n^2 G_{nk} - V_n V_m (G_k \cos(\theta_n - \theta_m) + B_k \sin(\theta_n - \theta_m)) - P_{knn}) = 0, \forall k \quad (4.5)$$

$$z_k (Q_{kmm} + V_m^2 B_k + V_m^2 B_{mk} + V_m V_n (G_k \sin(\theta_m - \theta_n) - B_k \cos(\theta_m - \theta_n))) = 0, \forall k \quad (4.6)$$

$$z_k (Q_{knn} + V_n^2 B_k + V_n^2 B_{nk} + V_n V_m (G_k \sin(\theta_n - \theta_m) - B_k \cos(\theta_n - \theta_m))) = 0, \forall k \quad (4.7)$$

$$\sum_{\forall k(.,n)} (z_k P_{kmm}) + \sum_{\forall k(n,.)} (z_k P_{knn}) - \sum_{\forall g(n)} P_g + P_{dn} = 0, \forall n \quad (4.8)$$

$$\sum_{\forall k(.,n)} (z_k Q_{kmm}) + \sum_{\forall k(n,.)} (z_k Q_{knn}) - \sum_{\forall g(n)} Q_g + Q_{dn} = 0, \forall n \quad (4.9)$$

$$P_{min} \leq P_g \leq P_{max}, \forall g \quad (4.10)$$

$$Q_{min} \leq Q_g \leq Q_{max}, \forall g \quad (4.11)$$

$$-\theta_{max} \leq \theta_n - \theta_m \leq \theta_{max}, \forall k \quad (4.12)$$

$$V_{min} \leq V_n \leq V_{max}, \forall n \quad (4.13)$$

$$z_k \in \{0, 1\}, \forall k \quad (4.14)$$

The constraints (3.2) and (3.3) are modified to (4.2) and (4.3) with the addition of the binary variable  $z_k$  to represent the status of each transmission line. When the line is in service,  $z_k = 1$  and (4.2) and (4.3) are similar to (3.2) and (3.3). When the transmission line is open  $z_k = 0$ , this makes the minimum and maximum branch rating capacities equal to zero, which forces the power flow on the corre-

sponding branch to zero. Similarly, Equations (3.4)-(3.7) are modified to (4.4)-(4.7) by the incorporation of transmission switching. Multiplying the real and reactive power balance Equations (4.4)-(4.7) with  $z_k$  forces these equations to zero, in case of an open transmission line and retains the power balance equations, in the case of a transmission line in service. As can be seen from the above formulation, this is a MINLP with the incorporation of the binary variable  $z_k$ .

The complexity of solving a MINLP has been explained in Section 4.3. Another formulation of transmission switching, which makes the binary variable into a continuous variable, is shown below. Equation (4.14) in the above formulation is substituted with (4.15) and (4.16).

$$0 \leq z_k \leq 1, \forall k \quad (4.15)$$

$$z_k(1-z_k) = 0, \forall k \quad (4.16)$$

Equation (4.15) makes  $z_k$  a continuous variable allowing any value between 0 and 1 to be assigned to  $z_k$  whereas (4.16) ensures that the value of  $z_k$  is either 0 or 1 only. This formulation makes transmission switching a nonlinear programming problem. However, each of the  $z_k$  values produce their own local optimal solutions based on Equation (4.16) and the optimization program terminates when the first feasible solution is obtained. This drawback, in addition to the non-convex nature of the problem combined with the hard constraints of ACOPF retains the complexity of the formulation and makes it a very difficult problem, which still cannot be solved by current available solvers. In view of this, the initial formulation of network topology optimization with ACOPF is henceforth used in all computations.

#### **4.5 IEEE 118 Bus Test System**

The ACOPF with network topology optimization formulation shown in Section 4.3 is written in AMPL, a mathematical modeling language. A nonlinear optimization solver, KNITRO was used for the ACOPF with transmission switching. The data for the 118 bus system was obtained from [22] and was modified to meet the AC requirements. The test system is comprised of 118 buses, 24 generators and 186 transmission lines. The total real power capacity of the test system is 6806.2 MW and the reactive power capacity is 7029 MVA<sub>r</sub> with the total demand on the system at 4519 MW.

The transmission lines' capacities and generator cost information have been obtained from [17]. The largest generator has a maximum capacity of 805.2 MW and the smallest generator has a maximum capacity of 100 MW. The minimum capacity of all the generators is assumed to be 0 MW as unit commitment is not considered in the AC formulation.

#### **4.6 Results and Analysis**

The original ACOPF without transmission switching was solved in KNITRO and the total generation cost was found to be at 2986.59 \$/h. The entire optimization problem was solved in 18.09 s. Due to the complexity of a MINLP problem and the unavailability of solvers, the optimal line to be opened when transmission switching is incorporated in ACOPF is found using a brute force method. The optimization problem is solved repeatedly by opening up each individual transmission line in the system and the transmission line that, when out of service, results in the least generation cost is selected as the optimal line to be

opened. This technique of testing every line in the network is not conducive for practical application of transmission switching due to its computational inefficiency. For this reason, this method only serves as an investigative approach to determine the effect of network topology optimization in the AC setting.

The optimal line to be opened for the IEEE 118 bus test system found by this method was line 32, shown in Fig.4.1, with the total generation cost at 2925.82 \$/h. For a better understanding, the results are expressed in terms of % savings in cost from the original formulation to ACOPT with switching. In this case a total of 2.03% economic savings were achieved by taking line 32 out of service.

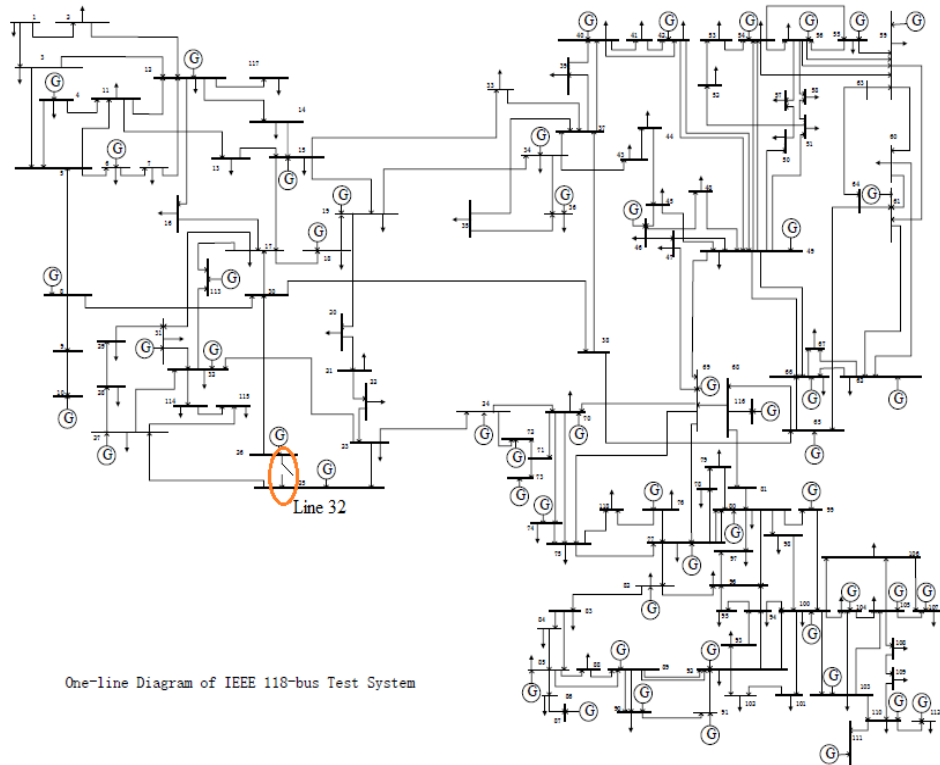

Fig.4.1 One line diagram of IEEE 118 bus test system with line 32 open

The following Table 4.1 shows the percentage savings in total generation cost for the IEEE 118 bus test system with a load of 4519 MW against the number of lines opened and the computational time for each of the optimization problems.

Table 4.1 Transmission switching results for IEEE 118 bus case

Number of lines open	% savings in total generation cost	Time to solve (h)
1	2.03	1.2
2	3.75	1.87
3	4.3	11.03

Fig.4.2 is a graphical representation of the economic savings of the system with transmission switching. It is to be observed that with the opening of the single best line, there is a 2% savings in generation cost. Though the savings in cost increase as more lines are opened, the percentage of savings obtained by opening two lines is not as high as that obtained by opening the first line alone. This method has the disadvantage of a very long computational time. As seen from Table 4.1, it takes over an hour to find the single best line to be opened in the 118 bus test case. A heuristic is suggested in the later chapters to overcome this high computational time. Another drawback of this method is that the optimality of the solutions cannot be guaranteed. When more than one line is to be opened, this technique finds the next best line to be opened given that the single best line chosen in the first iteration remains open during the rest of the iterations. However, it is possible that there exists another combination of lines to be opened that could give a better or at least as good as the solution that is obtained by this method.

Nevertheless, the solution obtained by this method still yields significant economic savings.

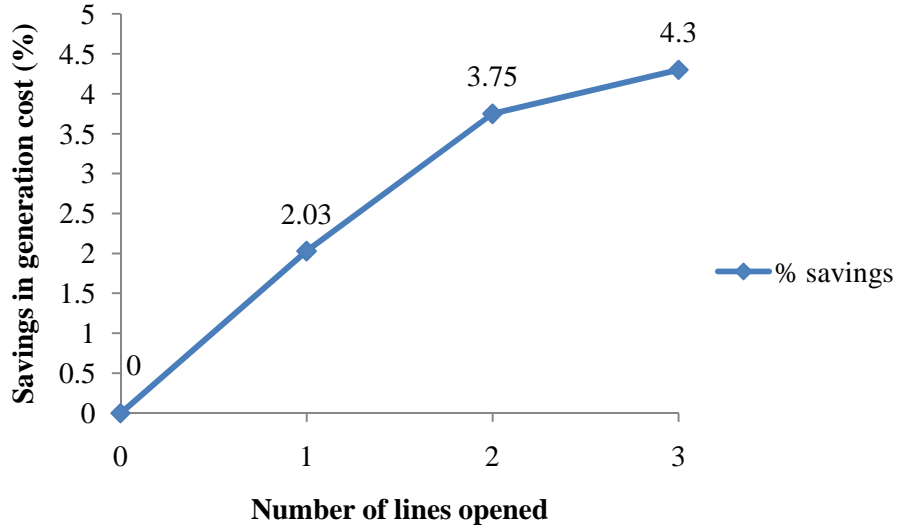

Fig.4.2 Graph showing economic savings against number of lines open for IEEE 118 test system.

#### 4.7 Effect on Varying Loads

A light coming on or a fan turning off, such everyday activities cause a varying load profile. This fact leads to a discussion on the effect of transmission switching on varying loads. Moreover, references to the implementation of transmission switching at lightly loaded levels to overcome voltage violations can be found in the literature. References [23] and [24] indicate procedures to switch transmission circuits, as a part of contemporary industry practices to handle voltage violations.

Two types of load variations are considered for the 118 bus test system described in Section 4.4. Firstly, a set of random variations of the load are considered and network topology optimization is performed on them.

Four different load levels including the original 4519 MW are taken and the results are presented in Table 4.2. As mentioned in the earlier section, the time to solve for the above optimization problems is high and increases as the number of lines to be opened increases. It is also concluded that there is no pattern in the time to solve as the load increases. This is mainly because of the difference in operating conditions of the various loads and it need not necessarily be faster to solve for a lower load level than a higher load level.

Table 4.2 Results of switching at varying load levels for 118 bus test case

	Load Level (MW)			
	4017 MW	4242 MW	4519 MW	4957 MW
Total cost without switching (\$/h)	1458.87	1735.77	2986.59	3912.3 9
Solution time (min)	0.475	0.202	0.302	0.215
% savings in cost with switching (1 line open)	3.73	3.54	2.03	1.89
Branch number of the opened line(s)	32	32	32	102
Solution time (min)	53.9	53.69	72.23	105.02
% savings in cost with switching (2 lines open)	4.19	4.43	3.78	3.43
Branch number of the opened line(s)	32, 102	32, 5	32, 124	32, 102
Solution time (min)	88.8	76.8	112.2	98.4

The branch numbers of the lines to be opened are also presented in Table 4.2. It is observed that all the load levels except 4957 MW have line 32 in common to be opened for one transmission line to be opened. However, when 2 lines are to be opened, line 32 is common for all the load levels. This establishes the possibility of having a candidate set of lines that can be opened under different load levels for any given system. Having a set of candidate lines to study the impact of transmission switching, instead of performing the entire optimization process to find the single most optimal line, reduces the computational time greatly and helps overcome the high solution time factor mentioned earlier.

In addition to Table 4.2, a graphical representation of the % savings is presented below for a better understanding of the effect of transmission switching on different load levels. It is seen from Fig.4.3 that as the load level increases there is a consistent decrease in the percentage savings when the single most optimal line is opened.

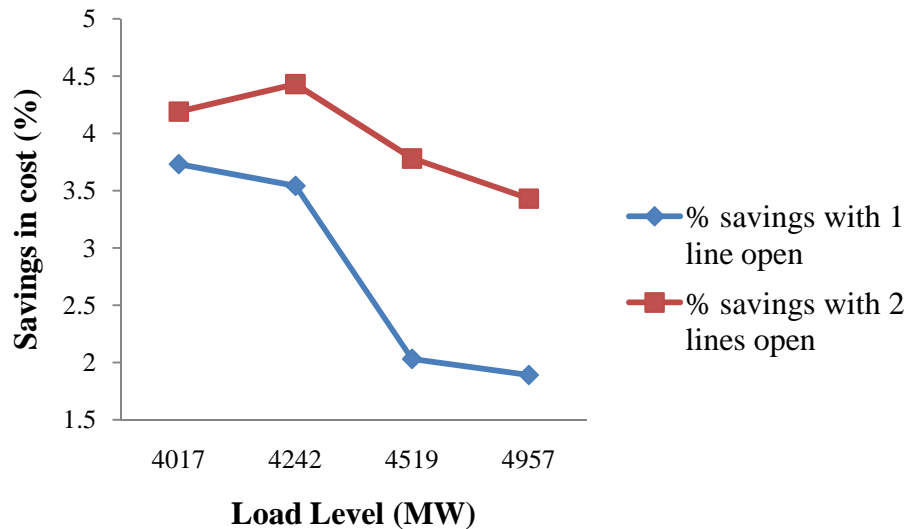

Fig.4.3 Graph representing the percentage savings when 1 and 2 lines are opened.



When 2 transmission lines are switched in the network, there is no observed trend in the percentage savings. This may be attributed to the previous statement made in Section 4.5 regarding the possibility of finding a better solution when more than one line is switched. The above process is repeated with a new set of load levels calculated as a percentage of the actual load of 4519 MW. The load levels considered are 80%, 90% 100%, 105% and 110% of the actual system load. The results of network topology optimization run on the above load levels are tabulated in Table 4.3 and show that the computational time continues to be high.

Table 4.3 Results of switching for loads as a % of the actual load level

	Load Level (MW)				
	80 % (3615.2)	90 % (4067.1)	100 % (4519)	105 % (4744.95)	110 % (4970)
Total cost without switching (\$/h)	1267.64	1847.36	2986.59	4146.13	5527.9
Solution time (min)	0.083	0.108	0.302	0.223	0.206
% cost savings with switching (1 line open)	6.01	3.15	2.03	2.15	1.27
Branch number of the opened line	123	125	32	32	32
Solution time (min)	25.17	51.51	72.23	149.19	91.69
% cost savings with switching (2 lines open)	9.12	4.45	3.78	2.70	1.51
Branch numbers of the opened lines	37, 123	135, 125	32, 124	32, 52	32, 47
Solution time (min)	69.6	88.2	112.2	850.2	99.6

Once again it is observed that most of the load levels have a common single best line to be opened, i.e., line number 32. Some of the parallel lines, like line 123 and 124, may also be considered in the candidate list of lines to be opened at some of the load levels. It is seen from the graph in Fig.4.4 that the percentage of savings decreases with an increase in load similar to the percentage savings observed with the previous set of randomly varying load levels. This section emphasizes the influence of transmission on varying loads and highlights some of the advantages of network topology optimization.

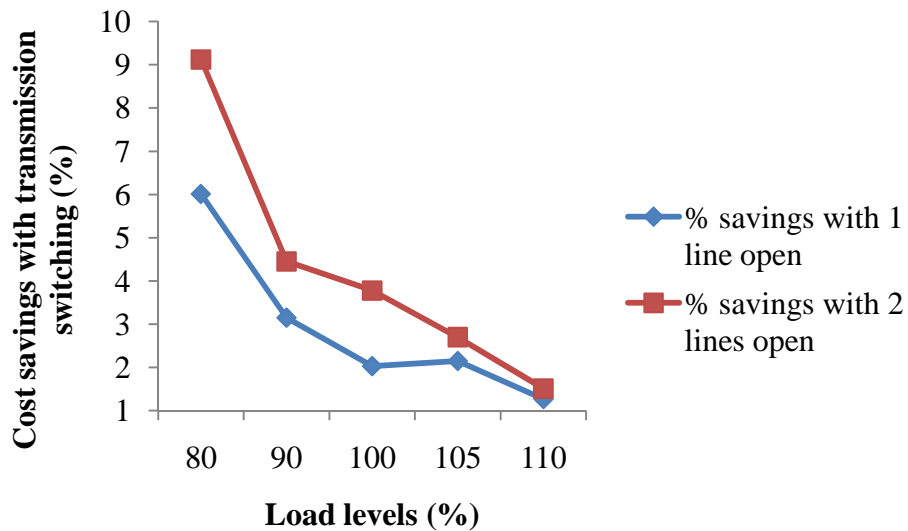

Fig.4.4 Graph showing cost savings against load levels in percentages.

#### 4.8 Losses

Previous sections of this chapter emphasized the economic savings obtained by transmission switching and its performance under varying load conditions. In the previous work of DC approximation of transmission switching, losses are neglected. This section proceeds to explain the impact of transmission switching on the losses in a system. It is a general assumption that there is an increase in

system losses when a transmission line is taken out of service. On the contrary, literature review of chapter 2 indicates that the concept of dispatchable networks is used for minimization of losses in a system, dispelling the above assumption. Nonetheless, it is not true that every line, when taken out of service results in reduced losses. It is not possible to predict whether the losses in a network increase or decrease when a line is taken out of service. The flows in an electric network are governed by Kirchhoff's laws. When a transmission line is switched off, this creates an entirely new optimization problem with a new operating state, which in turn leads to a new power flow profile. This is demonstrated by the results presented in this chapter.

The real power losses in the IEEE 118 bus test system have been calculated before and after switching and the results are shown below for a load level of 4519 MW. It is seen from Fig.4.5 that the real power loss of this system increases as more lines are opened. The economic savings of the system increase as number of lines opened increases although the losses also increase. However, it cannot be said conclusively that the losses always increase when a line is taken out of service. The graph shown in Fig.4.6 illustrates the possibility of decrease in losses with transmission switching and generation redispatch. The losses in an IEEE 118 bus test system with a load level of 4017 MW are plotted against the number of lines opened.

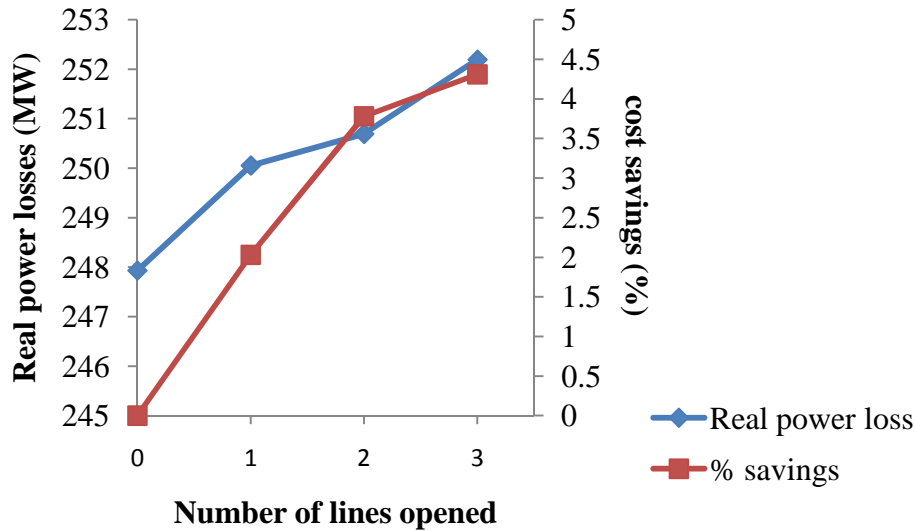

Fig.4.5 Graph showing real power losses and percentage savings against number of lines open in a 4519 MW 118 bus system.

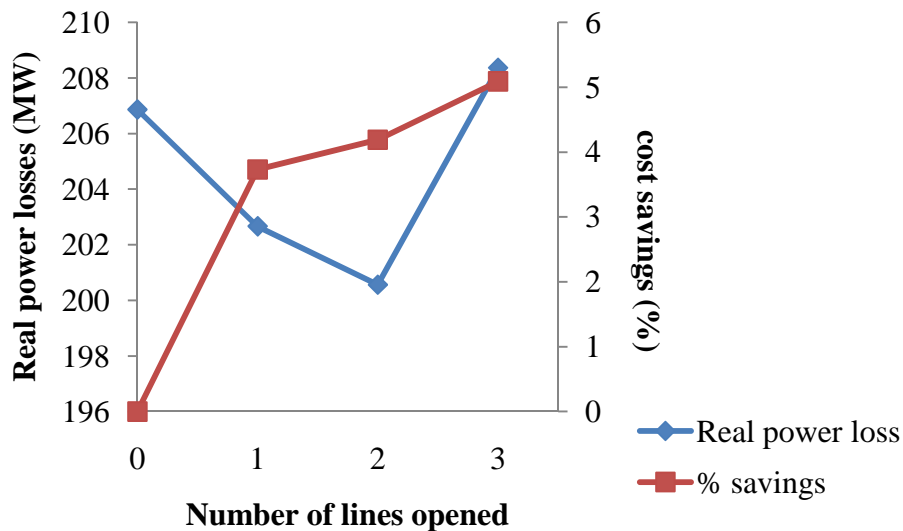

Fig.4.6 Graph showing real power losses and percentage savings against number of lines open in a 4017 MW 118 bus system.

It can be seen that when the single most optimal line is opened, losses decrease by 2%. The losses in the system further decrease by another 1% with 2 lines open. When 3 transmission lines are switched, losses increase above the total real power loss without switching. Even though the losses decrease initially and increase later on, the percentage savings in cost increase steadily with an increase

in the number of lines opened. This example demonstrates that the economic savings due to transmission switching are not dependent on system losses alone.

#### **4.9 Voltage**

Previous research on transmission switching with DCOPF works with the assumption that the voltage magnitude is 1.0 p.u. This research aims to explore the impacts of transmission switching on voltage without this assumption. There are instances in the literature, as mentioned in Chapter 2, where the concept of switching lines is used to overcome voltage magnitude violations. This research further explores the impact of transmission switching on voltage in a system.

It is very important that the voltages in a system are within their specified limits. Voltage magnitude violations can cause serious damage to the system and might lead to voltage instability and in some cases result in cascading outages. Over voltages can cause equipment damage and trip transmission elements. Under voltages cause the stalling of generating units and equipment malfunction. For these reasons, it is essential to study the impact of transmission switching on voltage of the system.

The graphs shown in Fig.4.7 and Fig.4.8 depict the voltage magnitude profile of the IEEE 118 bus test system with load levels of 4519 MW and 4957 MW respectively. The voltage magnitude limits are set at 94% to 106%. It can be observed from the below graphs that the voltage magnitude profile of the system with switching follows closely with that of the voltage magnitude profile without switching and the two profiles closely overlap each other to the point that they are relatively indistinguishable.

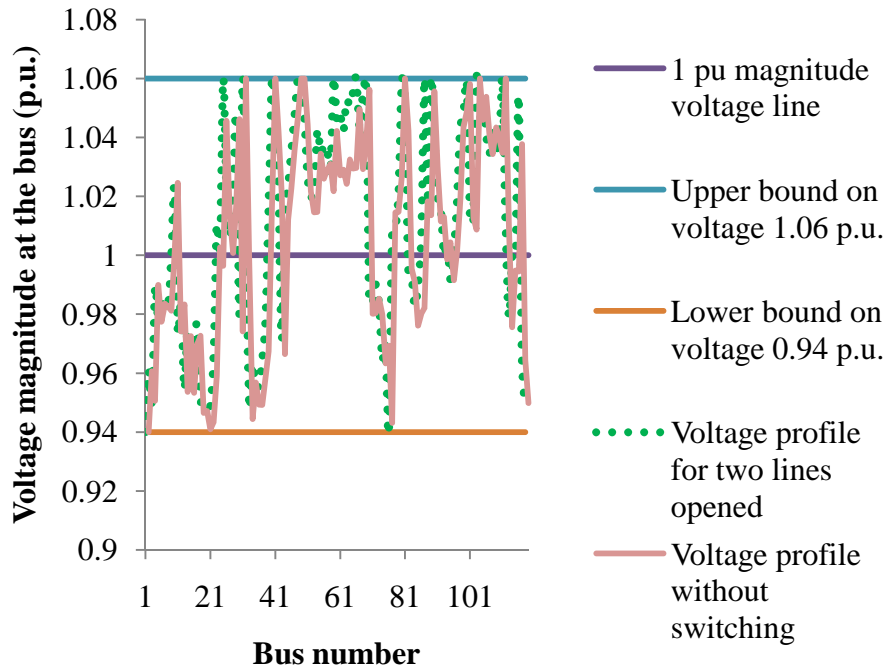

Fig.4.7 Voltage magnitude profile of IEEE 118 bus test system with load at 4519 MW.

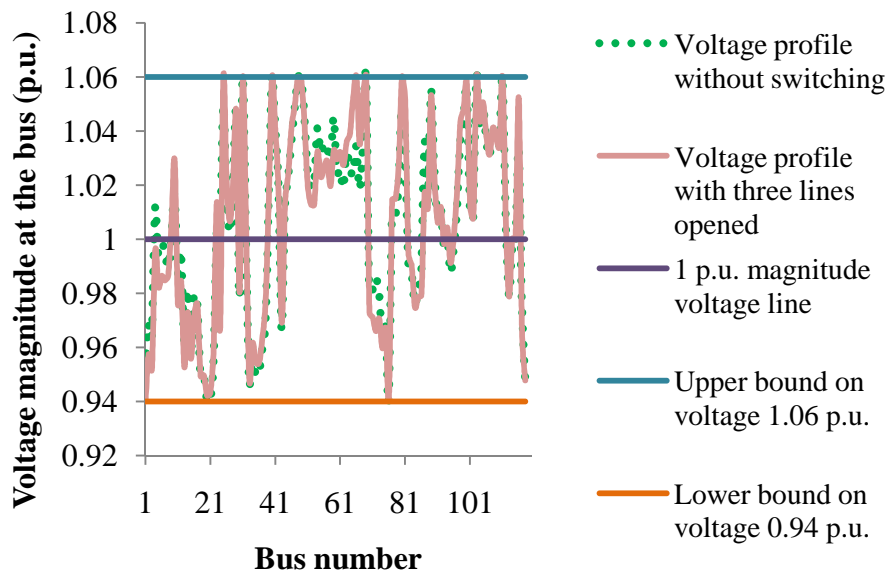

Fig.4.8 Voltage magnitude profile of IEEE 118 bus test system with load at 4957 MW.

In Fig 4.8, it is seen that there is an improvement in voltage magnitude with switching at some of the buses. This is in line with the research on switching of lines to improve on voltage presented in the literature review of Chapter 2.

The voltage magnitude of a system is closely related to its reactive power. Changes in reactive power profile affect the voltage magnitude of the system as well. A decrease in reactive power results in voltage magnitude drop and forces the current to increase in order to maintain constant power. This in turn needs more reactive power leading to a voltage collapse. Reactive power and voltage form two components of the power system that support reliability. In light of this, studying the impact of transmission switching on voltage magnitude is necessary to understand network topology optimization's effect on reliability of the system as well.

#### **4.10 Summary**

Dispatchable network topology in addition to deployment of generation assets has been explored in this chapter. The concept of network topology optimization has been introduced and the distinction between transmission planning and transmission switching has been clarified. The results of transmission switching along with ACOPF have been presented. Savings in cost of a total of 3% to 6% have been achieved. The losses in the system before and after transmission switching have been recorded and it can be concluded that the change in losses does not alone determine the economic savings of the system. It is difficult to predict whether the losses increase or decrease with the switching off of a particular line but it has been proven that there could be significant savings in total gen-

eration cost irrespective of this change in losses. Finally, the impact of transmission switching on the voltage magnitude profile of the system is analyzed and the importance of voltage magnitude and reactive power control for system reliability has been discussed.

This chapter provides insight into the unexplored potential of the concept of transmission switching and brings to light the improvement in dispatch efficiency that can be achieved through the implementation of this method. Even though the brute force method suggested above is not practically and computationally feasible for real world application today, the possibility of improvements in computational abilities and availability of commercial solvers for this very problem makes network topology optimization a viable solution for future implementation. Application of heuristics and genetic algorithms to achieve a good, if not the optimal, solution very fast has been discussed in Chapter 6.



## CHAPTER 5: COMPARISONS BETWEEN DC AND AC TRANSMISSION SWITCHING

### 5.1 Overview of DC Optimal Transmission Switching

Which is better: AC or DC? This is a question that was first raised in the late 1800s and continues to be a much investigated area of modern power systems. While Thomas Edison argued that DC was safer and simpler to work with, Nikola Tesla countered by arguing and proving that AC is cheaper and easier to transmit. Each of these forms of power has its own pros and cons and neither of them can be completely replaced by the other.

Today, the electric grid is primarily AC in nature except for a few high voltage DC transmission lines. A linearized approximation of the ACOPF called DCOPF is used for computation of the optimal power flow, for the sake of simplicity and ease of calculation. DCOPF is much faster and computationally efficient. For these reasons, the industry uses LP solvers to find the optimal solution for DCOPF and feeds in the DC optimal result as an initial solution to the ACOPF in order to generate an AC feasible solution. This method of operating the grid, however, does not guarantee the accuracy of the DCOPF solution while allowing for all the approximations that are made. In turn, this leads to another debate on which is more important: accuracy or computational efficiency.

Incorporating network topology optimization along with generation dispatch involves binary variables and makes the ACOPF, which is already a difficult non-convex optimization problem, an even harder problem to solve by creating a mixed-integer nonlinear program. As a result, approximations to the idea of

transmission switching with ACOPF may be necessary to implement this concept. For this reason, this chapter concentrates on making an association between AC and DC transmission switching. The accuracy of DC transmission switching and the computational efficiency of AC topology optimization are weighted against their counterparts in an effort to answer the above debate.

## 5.2 Network Topology Optimization with DCOFF

The objective of the DC optimization problem is to minimize the total generation cost. The formulation of DCOFF, along with this objective, is shown in Equations (3.14)-(3.19). A binary variable  $z_k$  is incorporated in this formulation to account for transmission switching similar to the ACOPF with network topology optimization formulation. When  $z_k=0$ , it is indicative of the specific transmission line  $k$  being out of service and  $z_k=1$  represents the transmission line is in service. The modeling of DCOFF with transmission switching is presented in this section.

$$\text{Minimize: } \sum_g c_g P_g \quad (5.1)$$

subject to:

$$-z_k P_{kmax} \leq P_k \leq z_k P_{kmax}, \quad \forall k \quad (5.2)$$

$$B_k(\theta_n - \theta_m) - P_k + (1 - z_k) M_k \geq 0, \quad \forall k \quad (5.3)$$

$$B_k(\theta_n - \theta_m) - P_k - (1 - z_k) M_k \leq 0, \quad \forall k \quad (5.4)$$

$$\sum_{\forall k(n,.)} P_k - \sum_{\forall k(.,n)} P_k + \sum_{\forall g(n)} P_g - P_{dn} = 0, \quad \forall n \quad (5.5)$$

$$P_{min} \leq P_g \leq P_{max}, \quad \forall g \quad (5.6)$$

$$-\theta_{max} \leq \theta_n - \theta_m \leq \theta_{max}, \quad \forall n \quad (5.7)$$

$$z_k \in \{0,1\}, \forall k \quad (5.8)$$

The line flow capacity constraint (3.15) is modified to (5.2) to reflect the state of the transmission line. The binary variable  $z_k$  forces the line flow to 0 when the transmission line is out of service and retains the original capacity limits when the line is in service. Constraint (3.16) is replaced by (5.3) and (5.4) to ensure that the constraints reflect a line being out of service when  $z_k=0$ . This is done by introducing a new variable  $M_k$  chosen to be large enough to make sure that (5.3) and (5.4) are not binding in the case where the transmission line is open. When the line is in service,  $z_k=1$  enforcing the two constraints to equality resulting in (3.16). A similar model for formulation of DCOPF with transmission switching was proposed in [17].

The IEEE 118 bus test system with a load level of 4519 MW described in Section 4.6 is used to perform the DCOPF study. The code is written in AMPL and the solver used is GUROBI, a MIP solver. The below constraint (5.9) is included in the code to impose a restriction on the number of optimal lines to be switched off, which is to be specified by the user before the code is run in AMPL.

$$\sum_k (1-z_k) = C, \forall k \quad (5.9)$$

### 5.3 Results of DC Transmission Switching

DCOPF of the original network without switching yields a total generation cost of 2135.14 \$/h within in a solution time of 0.047 s. When transmission switching is applied to find the single best line to be opened i.e.  $C=1$  in (5.9), the total cost of generation is found to be 1974.31 \$/h within a duration of 1.13 s. The

most optimal line to be switched off is found to be at line number 123 and yields total economic savings of 7.5 %. The graph in Fig.5.1 depicts transmission switching in DCOPF for the IEEE 118 bus test system.

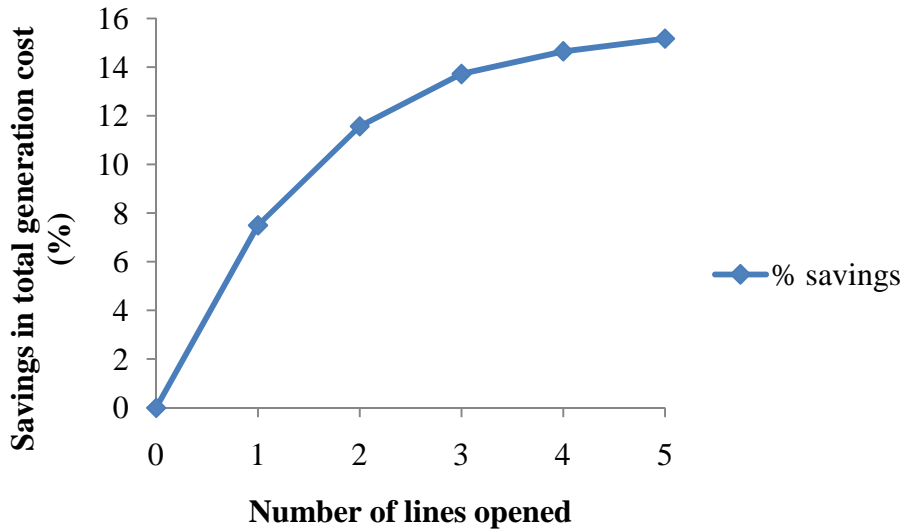

Fig.5.1 Results of IEEE 118 bus case DCOPF with transmission switching.

It is observed from the above graph that the savings increase gradually as the number of lines opened increase. The solution time for switching of lines also increases as well with the number of lines opened. This indicates the increase in complexity of finding the optimal solution as the number of transmission lines to be opened increases.

The need to examine the impact of optimal transmission switching on varying load levels is explained in Section 4.8 and the concept is revisited here in the DC setting. The graph in Fig.5.2 shows the effect of transmission switching at varying load levels of 4017 MW, 4242 MW, 4519 MW and 4957 MW. It can be concluded from the graph that no pattern can be attested to the percentage savings

in cost as the load increases. This is another exemplar to establish that the outcome of the optimization problem is largely dependent on the complexity of the system at any particular operating state and the optimal solution changes with every change in the operating conditions of the network.

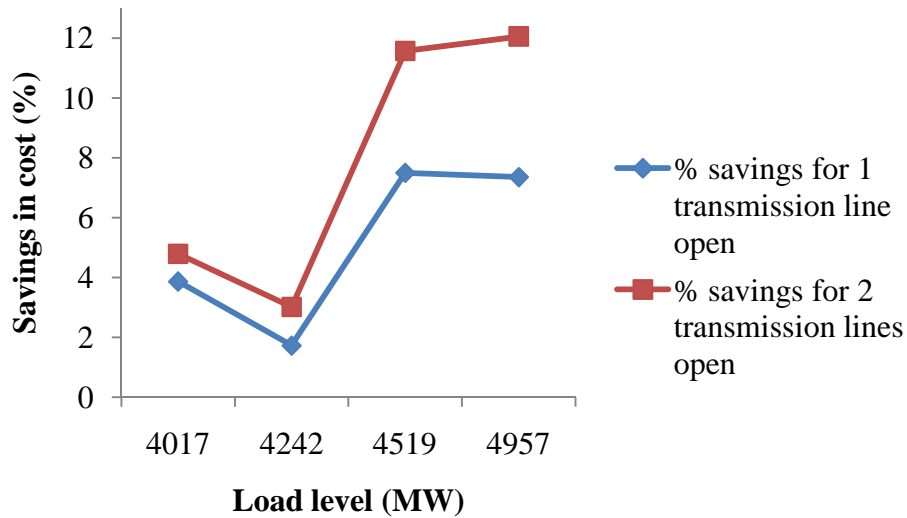

Fig.5.2 Network topology optimization with DCOPF at varying load levels.

Table 5.1 lists the optimal transmission lines that are to be opened at each load level. Though there is no recognizable pattern in the lines that are chosen to be opened among the different load levels, it is to be observed that there are certain lines that are repeatedly chosen as the optimal solution for most of the load levels, e.g., Line 123. This reiterates the possibility of having a set of candidate lines from which a good solution for network topology optimization can be achieved, which is important in order to achieve faster solution times.

Table 5.1 Transmission lines to switch for  $C=1$  and 2, varying load levels

Load level (MW)	Single best line to be opened, $C=1$	Best two transmission lines to be opened, $C=2$
4017	102	102 and 3
4242	52	50 and 37
4519	123	123 and 125
4957	123	37 and 123

It is also to be noted that for the load level of 4242 MW, the single best line to be opened is line 52 whereas the combination of 37 and 50 is the optimum solution for switching of two transmission elements. This example refers back to the statement made in the previous chapter regarding the optimality of the AC solution generated by a brute force method. When a complete enumeration method is applied to find the best two lines to be opened in an ACOPF in the previous chapter, the single best line solution is found first and that line is forced to be open throughout the other iterations where the process is repeated to find the second line to be switched. This technique excludes the possibility of a combination of lines, like 37 and 50 in the above test case, that are different from the single best line solution of 52 shown above, to yield a better solution. However, transmission switching with DCOPF ensures that the optimal combination of lines is chosen, demonstrating the computational efficiency of DC transmission switching.

## 5.4 Comparison between AC and DC Switching

A detailed analysis of the results of network topology optimization with ACOPF was presented in Chapter 4. The motivation of this section is to highlight the significant results of AC transmission switching in comparison with DC transmission switching. Fig.5.3 is a representation of the DC and AC transmission switching solution times and % savings obtained from the IEEE 118 bus test system with a real power load of 4519 MW.

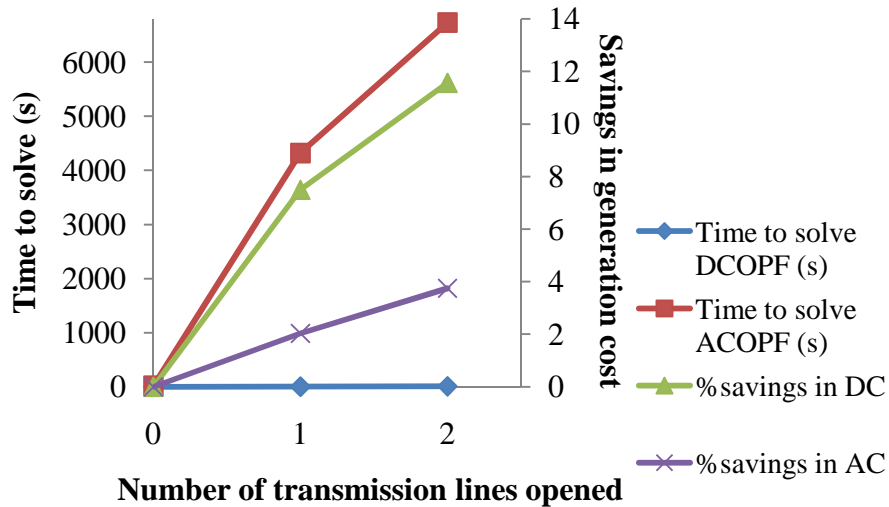

Fig.5.3 Comparison between AC and DC transmission switching for the IEEE 118 bus test system with load at 4519 MW.

The AC solution time is in hours and is quite high in comparison with the DC solution time. This reconfirms the computational efficiency of DCOPF with transmission switching. This is a major advantage of DC approximation as the high solution times of ACOPF make it impractical for real world applications. Given these complexities in ACOPF, an alternative approximation method similar to that of solving unit commitment problem in DCOPF can be devised for the implementation of network topology optimization as well. Therefore, this compari-

son of AC and DC transmission switching is essential to establish a relationship between the two models.

The graph in Fig.5.3 also plots the economic savings obtained in both AC and DC transmission switching optimizations. There is a wide disparity between the savings obtained in both the settings, bringing forth the question of accuracy. The savings obtained in the DC approximation do not necessarily represent the actual savings that can be obtained by transmission switching. Similarly, the savings shown in AC setting are not necessarily optimal due to the non-convexities that are present in the ACOPF, which make it extremely difficult to prove global optimality. However, this research has demonstrated the potential of network topology optimization. While solving network topology optimization with the ACOPF problem is currently too difficult on a large-scale with the available commercial software today, there is still the potential to implement network topology optimization through the use of the DCOPF, similar to what is done today for unit commitment. Hence, there is a need for further research on not only improving solution techniques for network topology optimization but also on dealing with the inaccuracies of the DCOPF transmission switching problem.

This research examines the performance of the DC optimal solution in an AC setting, to investigate how the inaccuracies from the DCOPF problem may affect network topology optimization. The optimal solution of the DCOPF for the IEEE 118 bus test system at load level of 4519 MW was line 123 with a savings of 7.5 %. This solution is used as a starting point for ACOPF transmission switching and the savings obtained using this approach are examined. It has been ob-



served that the total cost of generation for this ACOPF switching solution is higher than the dispatch cost of the original topology, which indicates that the lines that are optimal in the DCOPF framework need not necessarily be the best solutions in ACOPF and may even have a higher dispatch cost than the initial topology as indicated by this instance.

All feasible transmission lines with savings of above 2% in the DCOPF were taken as a candidate set for ACOPF with transmission switching and their performances were recorded as shown in Table 5.2. While the results in Table 5.2 show that many lines that are beneficial in the DCOPF problem are not beneficial in the ACOPF problem, this anecdotal evidence should not be assumed to produce a generic result. Further testing is needed to see if similar results are found for other test cases. Furthermore, it is always hard to have definitive results when solving an ACOPF problem due to its non-convexities as it is possible that the true global optimal solution is much better than what is being presented but the non-linear solver is simply not able to find it before it converges to a local optimal solution.

It is seen that lines that have significant savings in the DCOPF do not necessarily produce the same results in the ACOPF. It is to be noted that two of the lines, 116 and 185 that have over 2 % economic savings in the DCOPF, are infeasible in the ACOPF. The ACOPF solution with line 32 open results in economic savings of over 2 % but yields only a 0.9 % savings when opened in the DCOPF. It is also observed that some of the lines that produced significant savings when switched in the DCOPF model have an increase in the total generation cost when

switched in the ACOPF model, e.g., line 131 has a 7% savings when switched in the DCOPF model whereas the same line causes over 2% increase in generation cost when switched in the ACOPF model. The possibility of a DCOPF optimal solution being infeasible in ACOPF is also to be considered.

Table 5.2 Comparison of ACOPF performance with DC initial solutions

Line number	% savings with DCOPF	% savings with ACOPF
116	2.27	infeasible
122	2.11	-2.14
123	7.53	-37.35
124	3.72	0.59
125	5.5	-20.54
128	5.81	-12.28
130	6.03	0.22
131	7.39	-2.72
132	5.57	0.9
135	6.08	-0.78
136	4.92	-0.7
137	2.62	-0.37
150	2.60	0.63
156	2.73	0.27
185	2.19	infeasible

Similar to the testing of DC switching solution with ACOPF topology optimization, Table 5.3 demonstrates the performance of AC switching solutions with 1% or more economic savings, with DCOPF topology optimization. It is observed that lines 5 and 11 that have around 1% savings when switched in the ACOPF model cause an increase in the dispatch solution when switched in the DC model. Another interesting result seen in the performance of AC solutions is that line 32, the best line for topology optimization with ACOPF, has only a 0.89% savings in the DC model where it has shown the potential for over 2% savings in the ACOPF model. These results demonstrate the innate variations and the uncertainty of establishing a pattern between the AC and DC formulations.

Table 5.3 Comparison of DCOPF performance with AC initial solutions

Line Number	% savings with ACOPF	% savings with DCOPF
5	1.27	-0.84
11	1	-0.63
32	2.04	0.89

## 5.5 Conclusion

This chapter explores the possibility of generating a candidate set of transmission lines to be switched in an ACOPF based on the DCOPF optimal solution obtained. However, it has been established in Section 5.4 that there is an ambiguity in the performance of this candidate set in ACOPF with transmission

switching. This result emphasizes the idea stated throughout this thesis that any change in the operating state of the system results in a new power flow thereby creating new operating conditions. Dissimilarities as well as concurring points of ACOPF and DCOPF network topology optimization have been stated. It can be concluded that no standard pattern can be established between the DC and AC formulations of OPF with transmission switching. This calls for further research on heuristic techniques that overcome the primary disadvantages of AC and DC namely high solution time and accuracy of system representation respectively, and are discussed in the following chapter.

## CHAPTER 6: HEURISTICS FOR PRACTICAL APPLICATION

### 6.1 Introduction to Heuristic Techniques

The solution techniques used in previous chapters were meant to study the problem of network topology optimization and to allow for a comparative analysis of the DCOPF versus the ACOPF network topology optimization. To use a complete enumeration/brute force technique as was the case in the previous chapters will not work for real-world applications. Therefore, there is a need for solution techniques that can provide good solutions in a reasonable amount of time. This chapter develops a heuristic based solution technique for the network topology optimization problem.

Heuristic techniques are used as a means of generating satisfactory solutions at a faster rate than an exhaustive search or other optimization techniques. As it has been pointed in the previous chapters, the solution time for finding the single best line to be opened is over an hour when using a brute force approach. The optimality of the solution also cannot be proven. The complexity of the problem only increases with application to a larger real world power system. In light of this, use of heuristic techniques exhibit the potential of practical application of network topology optimization with respect to the problems of computational efficiency. A heuristic provides the solution to the complex non convex, nonlinear optimization problem within half the actual time. These methods do not guarantee optimality; however, normal optimization techniques that can guarantee optimality take too long to solve and are unlikely to find the optimal solution within the

timeframe to solve the problem. Thus, the motive is to find good feasible solutions fast, which is fulfilled by using a heuristic.

## **6.2 Evolutionary and Genetic Algorithms**

The possibility of implementing evolutionary algorithms to help find a good solution in a short period of time is to be explored to make network topology optimization viable for practical application. It has been shown in previous chapters that the solution time to find the single best line to be opened in a system is quite long and increases with the number of lines to be opened, as the complexity of the system increases.

Evolutionary algorithms are search methods employed in optimization problems to obtain solutions through the application of natural evolutionary techniques. The principles of survival of the fittest and natural selection are applied to the available pool of solutions and a candidate set of superior feasible solutions is obtained. An evolutionary algorithm is different from other optimization techniques in this aspect that the search yields a candidate set of solutions as opposed to a single best solution. The solution can be chosen from this set of solutions and the availability of a candidate set keeps the possibility of finding a better solution in a different location at a later time active.

Genetic algorithms are a class of heuristics that belong to the superset of evolutionary algorithms. Genetic algorithms are commonly proposed heuristics for optimization problems and they make use of the natural evolutionary principles of selection, mutation, and crossover to generate a population of solutions to choose from. These heuristics are generally faster than complete enumeration and

provide a wide array of possible solutions as opposed to finding only the best solution. On the other hand, the solution obtained with the heuristic is “best” only in comparison with other possible solutions from the candidate set and its optimality cannot be established. Nonetheless, the application of these search techniques to network topology optimization may help improve the computational efficiency while generating a good solution in a faster time than the complete enumeration technique [25]. The application of heuristics to network topology optimization is examined in the later sections of this chapter.

### 6.3 Application of Fuller’s Heuristic to AC Systems

The idea for the heuristic used in this chapter is based on the technique described in [26]. It describes a heuristic that repeatedly runs DCOPF by opening up lines based on a ranking system. The same ranking system is used in the proposed heuristic. However, the concept of ranking lines is now performed on the ACOPF solution of the initial heuristic. Fig.6.1 is a flow chart of the heuristic explaining the step by step procedure of this proposed technique.

ACOPF is solved for the original network topology and the lines in the network are ranked in the order of lowest to highest based on their rank,  $R_k$  as shown in Equation (6.1), where  $LMP_m$  is the Locational Marginal Price (LMP) at the “from” bus  $m$  and  $LMP_n$  is LMP at “to” bus  $n$ .

$$R_k=(LMP_n-LMP_m)P_k, \forall k \quad (6.1)$$

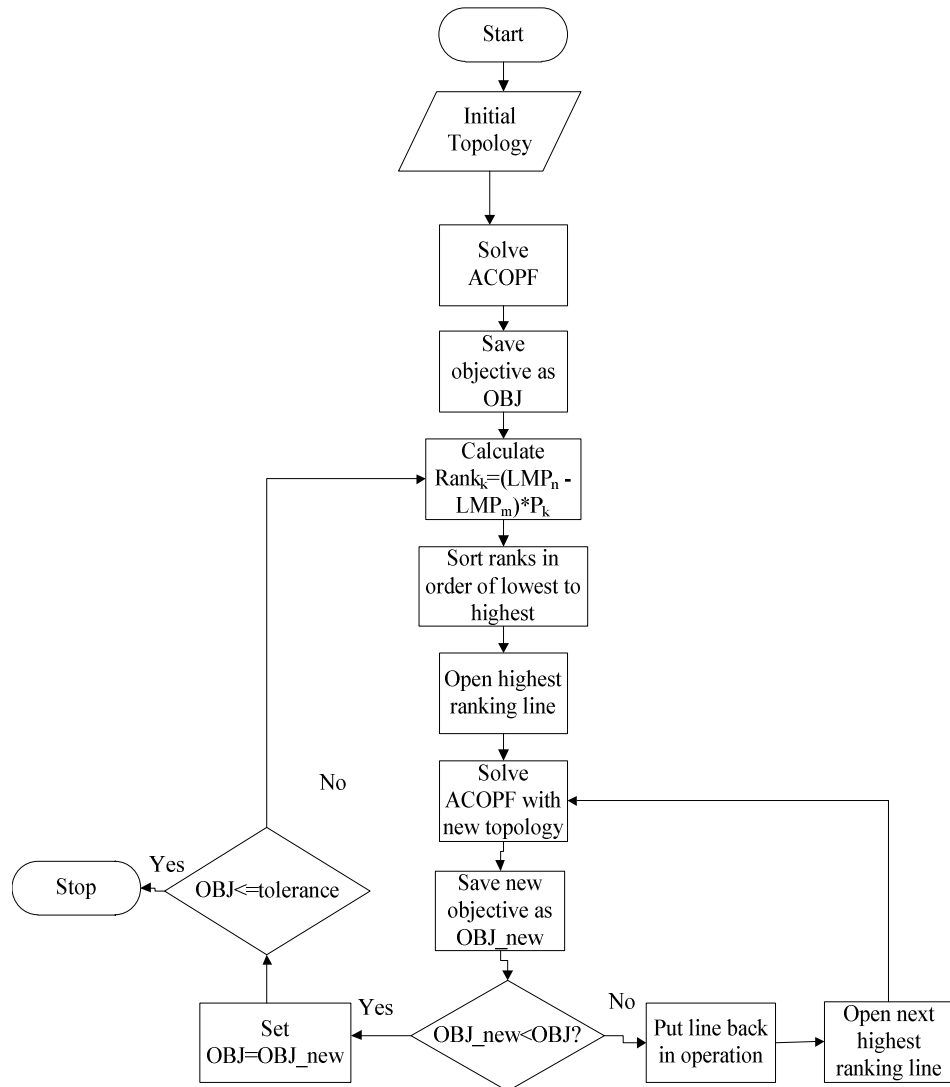

Fig.6.1 Flowchart of the heuristic with ACOPF

The highest ranking line is opened and the ACOPF is solved again. This objective is compared with the objective of the original network topology objective and if there is an improvement in cost, the line that is opened is chosen as the best line to be opened and is forced to remain open for the rest of the iterations. If the objective of the ACOPF with the highest ranking line opened is higher than the original topology's objective, the current line is switched back in service, the



second highest ranked line is opened and the procedure is repeated by iterating to the next line of the list until an improvement is achieved in the objective. If a second line is to be opened, this line is forced to remain open and then the lines are ranked again with the new line flows based on (6.1) and the entire process is repeated until the next best line to be opened is discovered. Although this method does not guarantee the optimal solution, it is shown in the following sections that a good feasible solution is achieved with significant reductions in the solution time.

#### **6.4 Results**

The heuristic described in Section 6.2 was coded in AMPL and the ACOPF was solved using KNITRO. The heuristic is tested on various load levels and the results are compared with the results obtained in Chapter 4. Fig.6.2 is a graph representing the heuristic results against the various load levels for one line open. It can be seen that the savings obtained by the heuristic, though lesser than the economic savings obtained by the complete enumeration method, are still significant. However, there is a huge improvement in the solution time with the use of the heuristic.

Where it took just under an hour to find a solution with savings of 3.5 % for a 4242 MW load system for the iterative ACOPF method, it takes only 27 seconds to get significant savings of 1.8% for the same system with the application of the heuristic. The reduction in savings is a tradeoff with the solution time in this case. However, it can be seen from the graph that the same solution of 1.89% savings is achieved by opening line 102 in both cases for a load of 4957 MW with

an enormous difference in the solution time. The improvement in solution time is also obvious from Fig.6.3 where it took over an hour for the iterative method to find a solution at all load levels but took only minutes for the heuristic to find a solution. Also, the economic savings achieved in both cases are closer to each other as the number of lines opened increases.

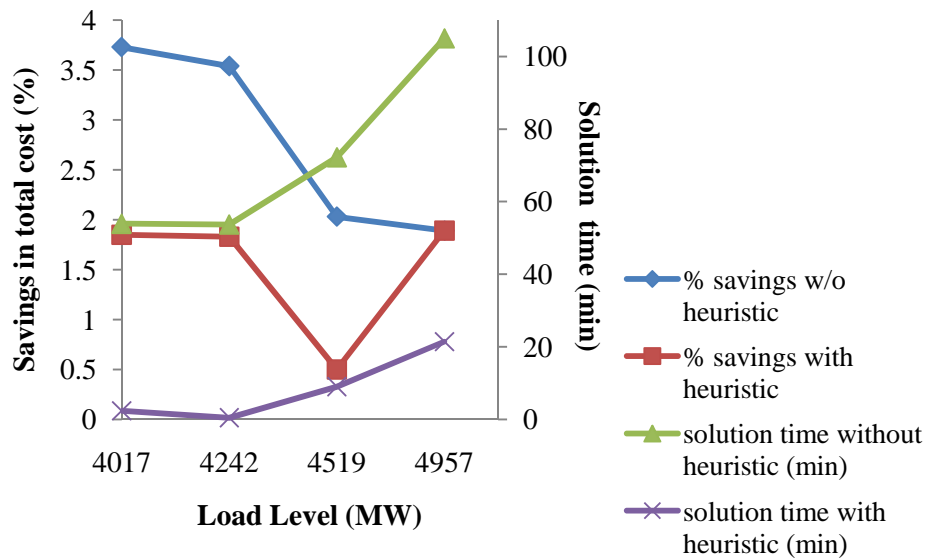

Fig.6.2 Heuristic performance with respect to brute force method for 1 line open

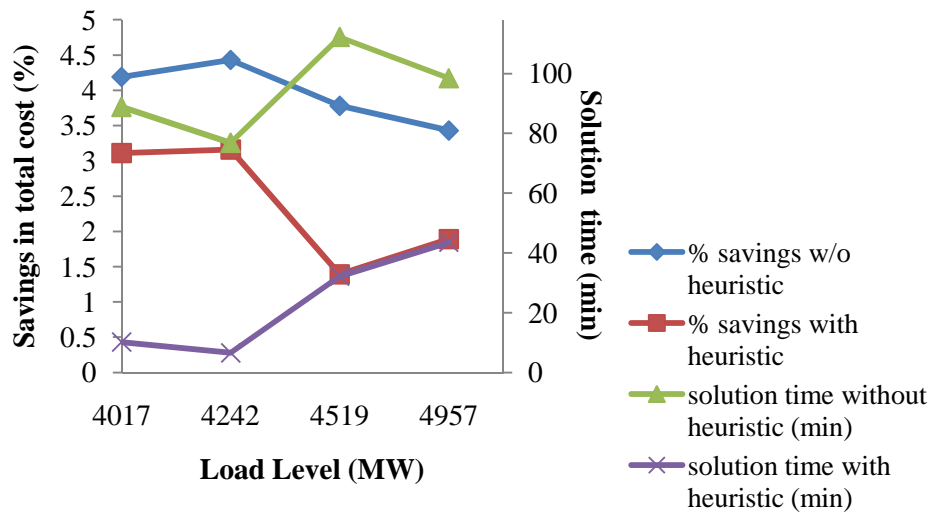

Fig.6.3 Heuristic performance with respect to brute force method for 2 lines open

The possibility of achieving better savings with the heuristic than the iterative method is also to be considered given that the optimality of the iterative method's solution is unproven. This was seen from the results obtained by both methods for the load level of 4242 MW when opening 3 lines. The heuristic generated a solution with 4.71% savings as opposed to 4.68% for solution without the heuristic.

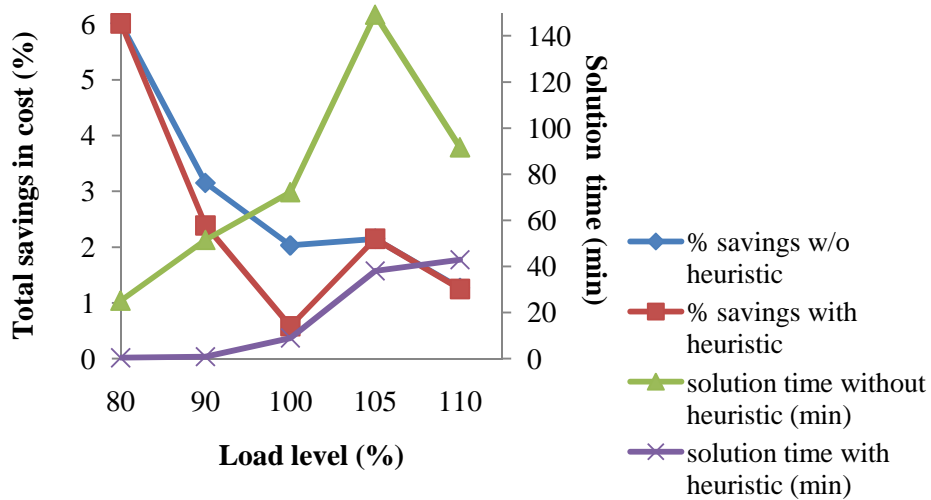

Fig. 6.4 Heuristic performance for load as % of 4519 MW for 1 line open

The above graph in Fig.6.4 depicts the performance of the heuristic against the iterative method for loads as a percentage of the actual load level of 4519 MW with 1 line open. It can be concluded for this set that the solutions are similar for most load levels and close to each other in the other case. Once again, the solution time of the heuristic is far shorter than the iterative method and is demonstrated most effectively by the example of opening 2 lines for 105% of the actual load level. Where it took 14.2 hours for the iterative method to find a solution of lines 32 and 52 with savings of 2.69%, the heuristic took only 1.07 hours

to find a solution of lines 32 and 37 with 2.39% savings. These results demonstrate the computational improvement achieved by performance of the heuristic. Thus, the heuristic produces good feasible solutions with vast improvements in solution time, emphasizing the potential benefits of network topology optimization while handling the challenges of transmission switching.

This heuristic may seem to be contrary to the common assumption as to what lines are the best to switch out of service. It is often assumed that lines that are fully loaded or capacity constrained are good candidates for switching actions. Another potential measurement is to use the LMP difference across the line times the line's flow and then to rank the lines from highest to lowest based on this value, which is the opposite of the ranking mechanism used in the above heuristic.

The following discussion analyzes the results of a heuristic ranking the lines based on (6.1) from highest to lowest. An attempt has been made to show that it is not always true that switching of fully loaded lines is economically beneficial to the system. The results below show the comparison of the two kinds of heuristics for both types of varying load levels.

As can be seen from the graphs in Fig.6.5 and Fig.6.6, there is no conclusion to be drawn that one heuristic is better than the other. It is observed from the random patterns of the graph that there is no standard substantial difference in either the economic savings or the solution time for the heuristics. Where the Fuller's heuristic of ranking lines from the lowest to highest seems to do better in case of Fig.6.5, the new heuristic suggested to order the lines from highest to lowest appears to be more efficient in the second graph, Fig.6.6. Thus, it cannot be

established that taking the most constrained transmission line out of service results in better savings.

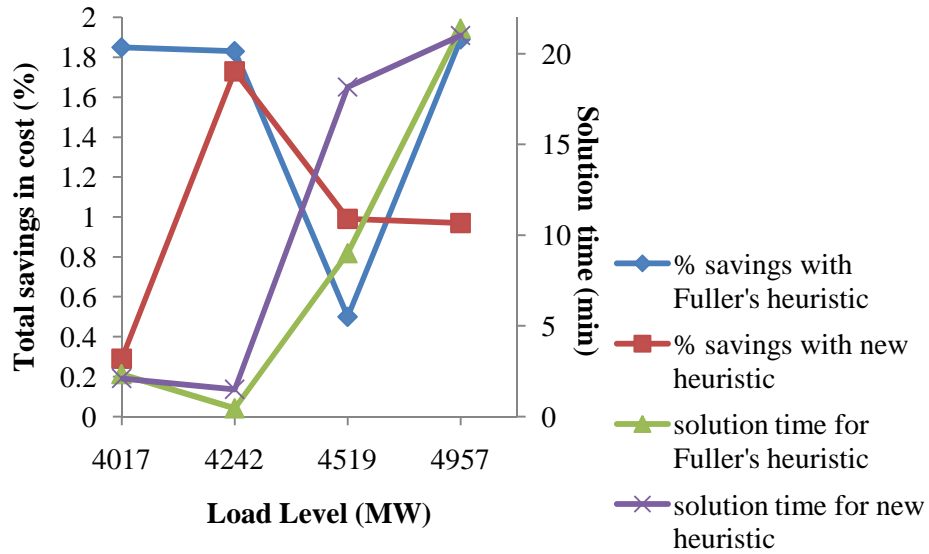

Fig.6.5 Heuristic comparison for varying load levels, one line open

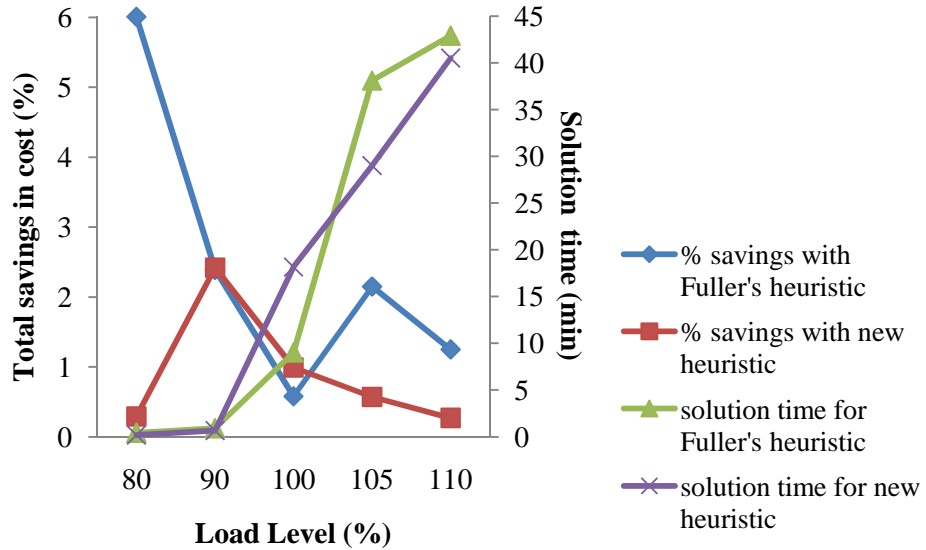

Fig.6.6 Heuristic comparison for load levels as % of actual load, one line open

## 6.5 Conclusion

Considering the computational inefficiency of the previously proposed exhaustive search method of network topology optimization with ACOPF, a heuristic based on Fuller's DC heuristic has been proposed to study the potential of practical implementation of this concept from the computational point of view. A comparison between the exhaustive search method and Fuller's heuristic is made to portray the enormous improvements in solution time made by the heuristic method. This development in solution time overshadows the lesser but still significant economic savings achieved by the heuristic method. As a side discussion, the general fallacy of the assumption that primarily fully loaded lines are the preferred lines to be taken out of service has been dispelled with the help of another heuristic. Thus, this chapter forms the basis for the possibility of practical implementation of the concept of topology optimization and encourages future research towards the development of new heuristics, e.g., genetic algorithms, in order to fulfill this goal.

## CHAPTER 7: CONCLUSIONS

Previous research on transmission switching emphasized the benefits of transmission switching for alleviating line overloads and to help with voltage and other constraint violations. The techniques and ad-hoc procedures adopted in current industry practices are described in Chapter 2. However, these practices do not consider the possibility of co-optimizing the network along with generation dispatch to create a superior and more efficient electric grid. The idea of a dispatchable network and its effects on the grid in combination with the DCOPF has been explored by [15] and [17]. This research further examines the effect of transmission switching on the network and studies the impact of switching from an AC perspective. It is of utmost importance to study the AC parameters that are approximated in the DCOPF and their behavior with network topology optimization with ACOPF, considering that the electric grid is primarily AC in nature.

The results from Chapter 4 confirm the thought that implementing an additional layer of flexibility to the transmission system not only improves utilization of resources but also provides significant economic savings in the total generation cost. The statement that, when a transmission line is taken out of service the generation is re-dispatched thereby changing the network flows and creating new system conditions, has been proven. Economic savings of up to 6% have been achieved by switching only 3 transmission lines. The possibility of higher savings is also to be considered by acknowledging that optimality cannot be established and so there might be a better solution yielding higher savings for the

specific optimization problem. It is also to be noted that the above mentioned savings were achieved by switching of only a few lines.

In any power system, the load is frequently changing and these changes in the loading level affect the flows on the transmission lines. As such, it is important to understand the performance of transmission switching at various load levels. This has been pursued in Chapter 4 and though the switching results do not have an established pattern, they indicate the possibility of establishing a candidate set of switchable transmission lines. Also, in most cases the percentage of economic savings gradually decreases as the load level increases, which seems contrary to what would be expected. Such a counter-intuitive result reconfirms the motive to develop systematic approaches to manage the grid due to its complexity. Furthermore, the results show that the concept of transmission switching is not detrimental to the voltage and reactive power of the system to the point that network topology optimization is not feasible. In addition, the impact of transmission switching on losses does not inhibit network topology optimization from obtaining a more economically efficient dispatch solution.

In Chapter 5, a comparison between the DCOPF results and the ACOPF results for transmission switching has been made. The similarities and differences between the two optimization problems are discussed. Though the solution time for DC transmission switching is less and the savings shown are greater, the amount of savings shown might not be the actual savings that can be obtained considering that there are a lot of assumptions with the DC network. Also, these results pertain to a particular network and, thus, these results should not be as-



sumed to be generic. Hence, it is essential to understand the similarities and differences between AC and DC switching and this knowledge can be used to get the DC network topology optimization model to be as close to the AC model as possible.

The addition of a binary variable representing the status of the transmission lines in the system made the ACOPF problem a MINLP. The structure of this MINLP with non-convex constraints is too complex to be handled by commercial solvers to date. Furthermore, exhaustive search techniques cannot be used on large-scale systems due to their long solution time. For this purpose, a heuristic that generates good feasible solutions in a short period of time has been proposed. This heuristic is based on a priority list that ranks the transmission lines in accordance to the LMP difference between the source and sink buses times the line flow. It has also been observed that the heuristic's performance in some cases has been as good as the exhaustive search method but with a huge improvement in the computational efficiency. This heuristic throws light on the possibility of the practical implementation of this concept.

This research indicates that the treatment of transmission elements as static assets is not always the most efficient way of operating the national electric grid. The redundancies built in to the network to account for contingencies are not necessary at every stage of operation. The results presented in this thesis demonstrate that not all the transmission lines present in the network are needed at every hour of operation. For this reason, the concept of network topology optimization is to be considered for creating a smarter and more efficient grid.

## CHAPTER 8: FUTURE RESEARCH

### **8.1 Overview**

This thesis answers the call for further research in making the electric network smarter, flexible and more efficient. In addition to studies conducted on transmission switching with ACOPF, this research also points towards potential future research topics in this area. The barriers to the concept of network topology optimization are discussed in this chapter and the need for future research will be pointed out.

### **8.2 Transient Stability**

Any disturbance in the network of a power system results in an immediate change in power flow and angular differences. If the disturbance is large, it may cause the machines to fall out of sync causing an instability in the system referred to as transient instability. When transmission lines are taken out of service, the switching action acts as a disturbance on the system and the transient stability of the system may be affected. Hence, it is important to study the effect of switching on the stability of the system to ensure that network topology optimization helps create an efficient and reliable power grid. There have been several instances in the literature, see [27] as well as industry practices [28] that utilize the concept of transmission switching without cause for transient stability concerns. These references provide the basis that switching actions do not always create transient stability issues. Nevertheless, further studies are to be conducted in this area to establish the impact of network topology optimization on transient stability.

### **8.3 Protective Devices/Relays**

Relay settings are used to provide protection to the power system against faults. They send signals to the circuit breakers to open up or close a line accordingly in order to isolate the fault. These settings are preprogrammed based on previous experience and by taking possible scenarios into consideration for a given network topology. However, the concept of network topology optimization changes the grid each time a line is taken out of service. Provisions have to be made to take this action into account while programming relay settings. Transmission lines are taken out of service for maintenance or for corrective actions even today and procedures to deal with these situations are already in place. Future research accounting for the idea of topology change on a more regular basis and its associated impact on relay settings is to be performed.

### **8.4 Circuit Breakers**

Transmission switching requires the operation of circuit breakers on a more regular basis. The increased use of circuit breakers may lead to increased maintenance requirements and more wear and tear on the breakers. The cost of replacing the breakers and the effect that switching would have on a circuit breaker is to be further studied. However, with the promise of substantial economic savings with transmission switching, the costs of replacing circuit breakers or improving the monitoring system of breaker status along with frequent maintenance are likely to be inconsequential in comparison.

## **8.5 Reliability**

The N-1 reliability of the transmission network with DCOPF transmission switching has been studied in [19] and it was shown that transmission switching ensures N-1 reliability subject to the assumptions of the model, e.g., the model is based on a DCOPF. While network topology optimization with ACOPF by itself is a difficult MINLP and cannot be handled by current day commercial solvers, the integration of a scenario based contingency analysis into this MINLP further complicates the optimization problem. One way to handle this complexity is to perform contingency analysis on an AC level similar to unit commitment. Unit commitment is performed with DCOPF and an AC feasible power flow with a fixed unit commitment solution is obtained. Similarly, an optimal solution to the optimization problem can be obtained first and contingency analysis can be performed to obtain an AC feasible power flow that is N-1 reliable. Further research is needed to determine the various approaches to ensure reliability with network topology optimization given the complexity of this problem. With that said, the current practices that utilize topology control provide the basis that reliability can be ensured with network topology optimization.

## **8.6 Heuristic Techniques**

One of the major challenges of network topology optimization is the computational complexity of this technique. It is essential to be able to generate a good feasible solution to the optimization problem within a given time frame. Hence, improvements in the solution times of DC as well as AC transmission switching are necessary. Although the complexity of solving the MINLP ACOPF

with transmission switching inhibits practical implementation of this technique on an ACOPF level, network topology optimization can be implemented in real world scenarios similar to a unit commitment problem that is solved on a DCOPF and implemented in AC. There is an urgent need for heuristics that can solve this optimization problem in a short period of time while still generating good feasible solutions.

Genetic algorithms that generate candidate lines using the principles of natural selection and mutation can find a good feasible solution with stopping criteria that limit the solution time to a desired minimum. These heuristics overcome the computational difficulties involved with network topology optimization and act as substitutes for the commercial software capable of solving an MINLP of this complexity. Though a heuristic has been proposed in Chapter 6, there is ample scope for further improvement in performance. Hence, future research utilizing these principles of genetic algorithms to provide better solution techniques for network topology optimization should be considered.

## BIBLIOGRAPHY

- [1].D. Gromko, "The need for a national smart grid," January 2011  
<http://leadenergy.org/2011/01/the-need-for-a-national-smart-grid/>.
- [2].R. Bacher, and H. Glavitsch, "Loss reduction by network switching," IEEE Transactions on Power Systems, vol. 3, no. 2, pp. 447-454, May 1988.
- [3].S. Fliscounakis, F. Zaoui, G. Simeant, and R. Gonzalez, "Topology influence on loss reduction as a mixed integer linear programming problem," IEEE Power Tech, pp. 1987-1990, Jul. 2007.
- [4].S. Fliscounakis, F. Zaoui, M. P. Houry, and E. Milin, "Loss reduction as a mixed integer optimization problem," IEEE Power Tech, pp.1-6, Jul. 2009.
- [5].A. A. Mazi, B. F. Wollenberg, and M. H. Hesse, "Corrective control of power system flows by line and bus-bar switching," IEEE Transactions on Power Systems, vol. 1, no.3, pp.258-264, Aug. 1986.
- [6].A. G. Bakirtzis and A. P. (Sakis) Meliopoulos, "Incorporation of switching operations in power system corrective control computations," IEEE Transactions on Power Systems, vol. 2, no. 3, pp. 669-675, Aug. 1987.
- [7].G. Schnyder and H. Glavitsch, "Integrated security control using an optimal power flow and switching concepts," IEEE Transactions on Power Systems, vol. 3, pp. 782-790, May 1988.
- [8].B. Perunicic, M. Ilic, and A. Stankovic, "Short time stabilization of power systems via line switching," IEEE International Symposium on Circuits and Systems, vol. 1, pp.917-921, Jun. 1988.
- [9].J. N. Wrubel, P. S. Rapcienski, K. L. Lee, B. S. Gisin and G. W. Woodzell, "Practical experience with corrective switching algorithm for on-line applications," Proceedings of IEEE Power Industry Computer Application Conference, pp.365-371, May 1995.
- [10]. J. G. Rolim, and L. J. B. Machado, "A study of the use of corrective switching in transmission systems," IEEE Transactions on Power Systems, vol. 14, pp. 336-341, Feb. 1999.
- [11]. W. Shao, and V. Vittal, "Corrective switching algorithm for relieving overloads and voltage violations," IEEE Transactions on Power Systems, vol. 20, no. 4, pp. 1877-1885, Nov. 2005.

- [12]. M. Li, P. B. Luh, L. D. Michel, Q. Zhao and X. Luo, "Corrective line switching with security constraints for the base and contingency cases," IEEE Transactions on Power Systems, pp. 1-9, Sep. 2011.
- [13]. G. Granelli, M. Montagna, F. Zanellini, P. Bresesti, R. Vailati, and M. In-norta, "Optimal network reconfiguration for congestion management by deterministic and genetic algorithms," Electric Power Systems Research, vol. 76, pp. 549-556, Apr. 2006.
- [14]. F. Kunz, "Congestion management in Germany – the impact of renewable generation on congestion management costs," May 2011, Available: [http://idei.fr/doc/conf/eem/papers\\_2011/kunz.pdf](http://idei.fr/doc/conf/eem/papers_2011/kunz.pdf).
- [15]. R. P. O'Neill, R. Baldick, U. Helman, M. H. Rothkopf and W. Stewart, "Dispatchable transmission in RTO markets," IEEE Transactions on Power Systems, vol. 20, pp. 171-179, Feb. 2005.
- [16]. E. B. Fisher., R. P. O'Neill, and M. C. Ferris, "Optimal transmission switching," IEEE Transactions on Power Systems, vol. 23, no. 3, pp. 1346-1355, Aug. 2008.
- [17]. K. W. Hedman, R. P. O'Neill, E. B. Fisher, and S. S. Oren, "Optimal transmission switching – sensitivity analysis and extensions," IEEE Transactions on Power Systems, vol. 23, no. 3, pp. 1469-1479, Aug. 2008.
- [18]. K. W. Cheung, Jun Wu, and R. Rios-Zalapa, "A practical implementation of optimal transmission switching," 4<sup>th</sup> International Conference on Electric Utility Deregulation and Restructuring and Power Technologies, pp. 366-371, Jul. 2011.
- [19]. K. W. Hedman, M. C. Ferris, R. P. O'Neill, E. B. Fisher, and S. S. Oren, "Co-optimization of generation unit commitment and transmission switching with N-1 reliability," IEEE Transactions on Power Systems, vol. 25, no. 2, pp. 1052-1063, May 2010.
- [20]. K. W. Hedman, R. P. O'Neill, E. B. Fisher, and S. S. Oren, "Smart flexible just-in-time transmission and flowgate bidding," IEEE Transactions on Power Systems, vol. 26, no. 1, pp. 93-102, Feb. 2011.
- [21]. K. W. Hedman, S. S. Oren, and R. P. O'Neill, "Revenue adequacy constrained optimal transmission switching," 44<sup>th</sup> Hawaii International Conference on Systems Sciences, pp. 1-10, Jan. 2011.

- [22]. University of Washington, Dept of Electrical Engineering, "Power System Test Case Archive," May 2010. Available: <https://www.ee.washington.edu/research/pstca/index.html>.
- [23]. Northeast Power Coordinating Council, Guidelines for inter-area voltage control. New York, NY: NPCC Operating Procedure Coordinating Committee and NPCC System Design Coordinating Committee, 1997.
- [24]. ISONE, ISO New England Operating Procedure no. 19: Transmission Operations, pp. 7–8, Apr. 13, 2007.
- [25]. Anonymous, "Genetic algorithm," Available: [http://en.wikipedia.org/wiki/Genetic\\_algorithm](http://en.wikipedia.org/wiki/Genetic_algorithm).
- [26]. D. J. Fuller, R. Ramasra, and A. Cha, "Fast heuristics for transmission line switching," IEEE Transactions on Power Systems, submitted for publication, April 2011.
- [27]. S.Chen, and H.Glavitsch, "Stabilizing switching," IEEE Transactions on Power Systems, vol. 8, no. 4, pp. 1511-1517, Nov. 1993.
- [28]. PJM, Manual 3: Transmission Operations, Revision: 35, October 5, 2009. Section 5: Index and Operating Procedures for PJM RTO Operation. Available: <http://www.pjm.com/markets-and-operations/compliance/nercstandards/~media/documents/manuals/m03.ashx>
- [29]. California ISO, Minimum Effective Threshold Report, March 2010, Available: <http://www.caiso.com/274c/274ce77df630.pdf>.
- [30]. P. A. Ruiz, J. M. Foster, A. Rudkevic, and M. C. Caramanis, "On fast transmission topology control heuristics," 2011 IEEE Power and Energy Society General Meeting, pp. 1-8, July 2011.



APPENDIX A  
NOMENCLATURE

### Sets

$g$ : Set of all generators

$g(n)$ : Set of all generators located at bus  $n$

$k$ : Set containing all transmission lines

$k(n,.)$ : Set of transmission lines with  $n$  as the “to” bus

$k(.,n)$ : Set of transmission lines with  $n$  as the “from” bus

$n$ : Set of all buses

### Variables

$P_g$ : Real power generated by generator  $g$  located at bus  $n$

$P_{kmn}$ : Real power flow on line  $k$  from bus  $m$  to bus  $n$

$P_{knm}$ : Real power flow on line  $k$  from bus  $n$  to bus  $m$

$Q_g$ : Reactive power generated by generator  $g$  located at bus  $n$

$Q_{kmn}$ : Reactive power flow on line  $k$  from bus  $m$  to bus  $n$

$Q_{knm}$ : Reactive power flow on line  $k$  from bus  $n$  to bus  $m$

$V_n$ : Voltage magnitude at bus  $n$

$V_m$ : Voltage magnitude at bus  $m$

$z_k$ : status of transmission element (0 for line out of service, 1 for line in service)

$\theta_n$ : Voltage angle at bus  $n$

$\theta_m$ : Voltage angle at bus  $m$

### Parameters

$B_k$ : Series susceptance of transmission line  $k$

$B_{mk}, B_{nk}$ : Shunt susceptance of transmission line  $k$  at bus  $m$  and  $n$  respectively

$c_g$ : Generation cost of generator  $g$

$G_k$ : Series conductance of transmission line  $k$

$G_{mk}, G_{nk}$ : Shunt conductance of transmission line  $k$  at bus  $m$  and  $n$  respectively

$P_{dn}$ : Real power demand at bus  $n$

$P_{kmax}$ : Maximum capacity rating of transmission line  $k$

$P_{min}, P_{max}$ : Real power generation limits on generator  $g$

$Q_{dn}$ : Reactive power demand at bus  $n$

$Q_{min}, Q_{max}$ : Reactive power generation limits on generator  $g$

$S_k$ : MVA rating of the transmission line  $k$

$V_{min}, V_{max}$ : Minimum and maximum ratings of bus voltage

$\theta_{max}$ : Maximum voltage angle difference