

Subunit Vaccine to Prevent Escherichia coli O157:H7 Intestinal Attachment  
and Colonization

by

Emel Topal

A Dissertation Presented in Partial Fulfillment  
of the Requirements for the Degree  
Doctor of Philosophy

Approved November 2010 by the  
Graduate Supervisory Committee:

Hugh S. Mason, Chair  
Scott E. Bingham  
Tsafrir Mor  
Robert W. Roberson

ARIZONA STATE UNIVERSITY

December 2010

## ABSTRACT

In the United States, *Escherichia coli* O157:H7 (*E. coli* O157:H7) is the most frequent cause of hemolytic uremic syndrome (HUS) and it is also the primary cause of acute renal failure in children. The most common route of the infection is ingestion of contaminated meat or dairy product originating from cattle or vegetables contaminated with bovine manure. Since cattle are the main reservoir for human infection with *E. coli* O157:H7, the reduction of intestinal colonization by these bacteria in cattle is the best approach to prevent human infections.

Intimin is an outer membrane protein of *E. coli* O157:H7 that plays an important role in adhesion of the bacteria to the host cell. Hence, I proposed to express intimin protein in tomato plants to use it as a vaccine candidate to reduce or prevent intestinal colonization of cattle with *E. coli* O157:H7. I expressed His-tagged intimin protein in tomato plants and tested the purified plant-derived intimin as a vaccine candidate in animal trials. I demonstrated that mice immunized intranasally with purified tomato-derived intimin produced intimin-specific serum IgG1 and IgG2a, as well as mucosal IgA. I further demonstrated that mice immunized with intimin significantly reduced time of the *E. coli* O157:H7 shedding in their feces after the challenge with these bacteria, as compared to unimmunized mice.

Shiga toxin is the major virulence factor that contributes to HUS. Since Shiga toxin B subunit has an important role in the attachment of the toxin to its receptor, I fused intimin to Shiga toxin B subunit to create multivalent subunit vaccine and tested the effects upon immunization of mice with the B subunit when combined

with intimin. His-tagged intimin, Shiga toxin B subunit, and Shiga toxin-intimin fusion proteins were expressed in *E. coli* and purified. I demonstrated that this multivalent fusion protein vaccine candidate elicited intimin- and Shiga toxin B-specific IgG1, IgG2a, and IgA antibodies in mice. I also showed a reduction in the duration of the bacterial shedding after the challenge compared to the control sham-immunized groups.

## DEDICATION

I dedicate this thesis to my devoted husband Timothy Patrick Hively and our gorgeous daughter Isabella Esin Hively who was born in June 11, 2010.

## ACKNOWLEDGMENTS

First of all I would like to thank to all my committee members for their support and guidance. I would like to express my genuine appreciation to my committee chair Dr. Hugh S. Mason for his sincere kindness, his patience, his scientific suggestion and most importantly for accepting me as a Ph.D. student in his lab and providing all the scientific tools necessary for my work. I am grateful to Dr. Scott Bingham for his amazing moral support and for his enthusiasm to help me in any subject that I needed. To Dr. Robert Roberson, for all his help with the electron microscopy techniques and it was exceptionally fun to work with him. Dr. Roberson's insightful comments greatly contributed to materialize another chapter of my thesis. To Dr. Mor, for the productive discussions and helpful suggestions at each committee meeting which helped me to shape up my thesis. I appreciate very much for David Lowry's assistance in the use of the electron microcopy. I wish to thank Dr. Alison O'Brien and James Sinclaire at Uniformed Services University of the Health Sciences, who provided materials for my work and helpful suggestions for interpretation of the data. I thank to Jacquelyn Kilbourne for technical assistance with mouse studies and to Dr. Melha Mellata for advice on the challenge study and the use of mouse facilities. I also owe debts of gratitude to Dr. Juergen Gadau for granting me the dissertation fellowship award which helped me to finish my thesis on time.

I owe my deepest gratitude to my best friend and an amazing scientist Dr. Lucrecia Alvarez, no words will ever be able to describe how much I appreciate her genuine friendship and contributions. I feel exceptionally lucky to have her as

my friend. Dr. Alvarez made this journey bearable with her love and jokes and without her support from the beginning to the end; it would not have been possible to complete this journey on time.

To my family and friends: First of all to my loving husband, without him standing by me I could not have made it to date. I am very grateful to have him in my life and I simply cannot find words to express how thankful I am to have him as a husband. I am very thankful for having my mother, Dudu Topal, and my father, Ismail Topal, as my parents. They have been very loving and supporting throughout my life and the most importantly they have always believed in me. I give special thanks to both of my sisters Evrim Topal and Esin Topal, for their endless love and support. I express gratitude to my parent in-laws, Kathleen Cullen and Don Cullen, for accepting me as one of their children since the beginning and for their support all the way through this journey. I give my thanks to Paul Arnold for moral emotional support and edition of the manuscripts. To future doctor Sun Hee Park for her scientific support and for many fun coffee and lunch hours that we shared to shared. I express my appreciation to Dr. Lolita George Mathew for making the science fun with her laughter. I would like to express my appreciation to my former English teacher and now friend Jean Schloeman, who taught me English when I was a foreign ESL (English as a second language) student in her class, and whose teaching went beyond her expectation since I am writing and defending my Ph.D. in English. Thank you very much to Joni Ward for her moral support, good food and for her excellent company. And Finally, I am very thankful to all of the colleagues that I meet

during my Ph.D. for their contribution in helping me to understand the life in a different perspective.

# TABLE OF CONTENTS

	Page
LIST OF TABLES.....	xi
LIST OF FIGURES.....	xii
CHAPTER	
1 INTRODUCTION.....	1
1.1 Pathogenic Escherichia Coli.....	1
1.2 EHEC O157:H7 infection and epidemiology.....	2
1.3 EHEC and Cattle.....	3
1.4 Virulence factors of EHEC O157:H7.....	5
1.4.1. Locus of enterocytes effacement.....	5
1.4.2. Intimin.....	5
1.4.3. The pO157.....	7
1.4.4. Shiga toxin.....	7
1.5. Shiga toxin and hemolytic uremic syndrome (HUS).....	9
1.6 Diagnosis.....	10
1.7. Recombinant subunit vaccines.....	11
1.8. Specific Aim of the Dissertation.....	14
2 PLANT DERIVED VACCINE TO PREVENT E. COLI O157:H7	
INTESTINAL ATTACHMENT.....	16
Abstract.....	16
1. Introduction.....	17
2. Materials and methods.....	20



2.1. Plasmid.....	20
2.2. Stable Transformation of Tomato.....	23
2.3. Protein Extraction from Fresh Leaves, Fresh Fruits and Freeze- Dried Fruits.....	24
2.4. Enzyme-linked Immunosorbent Assay (ELISA).....	24
2.5. Western Blot Analysis.....	25
2.6. Tomato Fruit Processing for Animal Trials.....	26
2.7. Protein Purification from Freeze-Dried Fruits.....	27
2.8. Deglycosylation of Purified IntC from Tomato Fruit.....	27
2.9. Animal Trials.....	27
2.10. Enzyme-linked Immunosorbent Assay (ELISA) to Determine IgG1 and IgG2 Titers in Mice Serum, and IgA Titer in Feces and Vaginal Lavages.....	29
2.11. Bacterial Challenge.....	30
2.12. Statistical Analysis.....	30
3. Results.....	31
3.1. Stable Transgenic Plants.....	31
3.2. IntC Expression in Freeze-Dried Tomato Fruits.....	31
3.3. IntC Purification from Freeze-Dried Fruits and Glycosylation of Purified Intimin.....	36

3.4. Immunogenicity of Tomato-Derived IntC.....	39
3.5. Bacterial Challenge of Immunized Mice.....	39
4. Discussion.....	46
3 SHIGATOXIN B -INTIMIN SUBUNIT FUSION VACCINE TO PREVENT ESCHERICHIA COLI O157:H7 INFECTION .....	49
Abstract .....	49
1. Introduction.....	50
2. Material and Methods.....	51
2.1. Plasmids.....	52
2.2. Bacterial Expression and Purification of StxB1, IntC and StxB1-IntC Fusion Protein.....	53
2.3. SDS-PAGE and Western-blot.....	54
2.4. Receptor binding of StxB1 and StxB1-IntC: Gb3 binding assay.....	56
2.5 Mouse immunization and challenge.....	56
2.6. Enzyme-linked Immunosorbent Assay (ELISA) to Determine IgG1 and IgG2a Titers in Mice Serum, and IgA Titers in Feces and Vaginal Lavages in mice.....	58
2.7. Statistical Analysis.....	59
3. Results.....	53
3.1. <i>E. coli</i> Protein Expression and Purification.....	60

3.2. Gb3 Receptor Binding of StxB1 and StxB1-IntC.....	65
3.3. Mouse Immunization.....	67
3.4. Challenge of Immunized Mice.....	74
4. Discussion.....	76
4 ELECTRON MICROSCOPY .....	82
Abstract .....	82
1.Introdcution.....	82
2. Materials and Methods .....	83
2. Results and Discussion .....	83
5 CONCLUSIONS.....	91
REFERENCES .....	93

## LIST OF TABLES

Table		Page
1.	Mice immunization groups and treatments .....	40
2.	IgG1 to IgG2a ratios for the mice immunized with tomato-derived intimin and mice in positive control .....	42
3.	Mice immunization groups and treatments for fusion protein.....	68
4.	IgG1 to IgG2a ratios in mice immunized.....	71

## LIST OF FIGURES

Figure		Page
1.	Plasmid constructs pNR49 and pNR50 were used for recombinant protein expression in tomato plants.....	22
2.	Expression of IntC in the first generation of tomato leaves.....	33
3.	IntC expression in the freeze dried tomato fruits from (A) T0 elite plants and (B) T1 elite plants.....	34
4.	Expression of IntC in freeze dried tomato fruits in T0 and T1 elite lines. ....	35
5.	Purification of IntC from tomato fruits and bacteria.....	37
6.	Glycosylation of the purified IntC .....	38
7.	Antigen-specific antibodies elicited in mice immunized with IntC ...	41
8.	Antigen-specific antibodies raised in mice immunized with IntC.....	43
9.	Shedding of bacteria after challenge with <i>E. coli</i> O157:H7 strain 86-24 Str .....	45
10.	Plasmid constructs pET26-StxB1IntC, pET26-StxB1, and pET26-IntC .....	61
11.	Expression of IntC. His-tagged antigens were expressed in <i>E. coli</i> , purified by metal affinity, and separated by SDS-PAGE.....	62
12.	Expression of StxB1. His-tagged antigens were expressed in <i>E. coli</i> , purified by metal affinity, and separated by SDS-PAGE.....	63
13.	Expression of StxB1-IntC. His-tagged antigens were expressed in <i>E. coli</i> , purified by metal affinity, and separated by SDS-PAGE.....	64

Figure	Page
14. StxB1 and StxB1-IntC pentamer formation and binding to Gb3 receptor.....	66
15. Antigen-specific serum IgG1 (A and B) antibodies elicited in mice immunized with IntC, StxB1 or StxB1-IntC .....	69
16. Antigen-specific serum IgG2 (A and B) antibodies elicited in mice immunized with IntC, StxB1 or StxB1-IntC .....	70
17. Antigen-specific fecal IgA (A and B) in mice immunized with IntC, StxB1, or StxB1-IntC. StxB1-IntC.....	72
18. Antigen-specific vaginal IgA (A and B) in mice immunized with IntC, StxB1, or StxB1-IntC .....	73
19. Bacterial shedding after challenge with <i>E. coli</i> O157:H7 strain 86-24 Str <sup>f</sup> .....	75
20. Transmission electron microscopy of the leaf of T <sub>1</sub> elite line: 49-4b.3 .....	85
21. Transmission electron microscopy of fruit of T <sub>1</sub> elite line: 49-4b.3 .....	86
22. Transmission electron microscopy of the leaf of T <sub>1</sub> elite line: 50-7.3 leaf.....	87
23. Transmission electron microscopy of the fruit of T <sub>1</sub> elite line: 50-7.3 .....	88
24. Transmission electron microscopy of wild type tomato leaves.....	89

25. Transmission electron microscopy of wild type tomato fruit ..... 90

## Chapter 1

### INTRODUCTION

#### 1.1 Pathogenic *Escherichia coli*

The bacterial species *Escherichia coli* was first described in 1885 by a German pediatrician and bacteriologist Theodore Escherich. *E. coli* is a gram negative, facultative anaerobe and characteristically colonizes the gastrointestinal tract of warm blooded animals and humans within a few hours after the birth (Nataro and Kaper 1998). *E. coli* lives in a mutualistic relationship with humans, where it benefits from the warmth, shelter, and nutrients provided by the colon, and in return make vitamin K. It also serves as a competitive inhibitor of pathogenic bacteria. *E. coli* live in a healthy host without causing any disease, but sometimes even non-pathogenic *E. coli* strains can cause diseases in an immunosuppressed host or in a host having disrupted gastrointestinal barriers (Kaper, J.P. et al. 2004). Although *E. coli* is a probiotic commensal bacterium, some strains evolved to have virulence factors adapted to different environments allowing them to cause a wide variety of diseases. The combination of different virulence factors creates different pathotypes of *E. coli*. According to general clinical syndromes, pathogenic *E. coli* can be responsible for sepsis/meningitis, urinary tract infections, and enteric/diarrheal disease. Diarrheagenic *E. coli* can further be categorized into six pathotypes: enterotoxigenic *E. coli* (ETEC), enteroaggravative *E. coli* (EAEC), diffusely adherent *E. coli* (DAEC), enteropathogenic *E. coli* (EPEC), and enterohaemorrhagic *E. coli* (EHEC).



Furthermore, *E. coli* serotypes are identified based on combination of the O (lipopolysaccharide, LPS) and H (flagellar) antigens, such as in *E. coli* O157:H7. In 1983 Karmali et al. (Karmali, Petric et al. 1983) described a cytotoxin produced by *E. coli* strains that is toxic for African green monkey kidney cells (Vero cells) and causes sporadic cases of hemolytic uremic syndrome. Subsequently, Riley et al. (Riley, Remis et al. 1983) identified *E. coli* O157:H7 as a cause of bloody diarrhea after the two main outbreaks of gastrointestinal illness in the United States. Riley et al. (1983) described the illness as characterized by severe abdominal cramps, bloody diarrhea and little or no fever. O'Brien et al. (O'Brien, Lively et al. 1983) documented that *E. coli* O157:H7 produces a toxin very similar to the toxin from *Shigella dysenteriae*: Shiga toxin. Since then, different studies revealed EHEC as a cause of hemolytic uremic syndrome (HUS) and non-bloody/bloody diarrhea (Karch, Tarr et al. 2005) in the United States and all around the world.

## 1.2. EHEC O157:H7 Infection and Epidemiology:

Individuals infected by EHEC O157:H7 can possibly experience an illness ranging from mild or bloody diarrhea to HUS. HUS is characterized by microangiopathic hemolytic anemia, thrombocytopenia, and acute renal failure (Scheiring, Andreoli et al. 2008). HUS can also further be divided into diarrhea (D+) and non-diarrhea associated (D-) disease. D+ HUS is generally associated with *E. coli* O157:H7 infection. Indeed, EHEC O157:H7-mediated HUS is the primary cause of acute renal failure in children in the United States and Canada.

In the United States 73,480 infections, 2168 hospitalizations, and 61 deaths occur per year (Mead, Slutsker et al. 1999; Yoon and Hovde 2008) with an estimated annual disease cost of \$0.5-\$3.3 billion (Frenzen, Drake et al. 2005).

Human infection with *E. coli* O157:H7 has been reported in more than 30 countries. Epidemiological studies have shown that EHEC O157:H7 can be found in domestic animals, especially in cattle, regardless of geographical regions (Beutin 2006). Since a very wide spread outbreak of EHEC O157:H7 infections in humans in the United States in 1982, which was associated with ground beef consumption, the bovine reservoir has been confirmed as a source of these infections (Armstrong, Hollingsworth et al. 1996). Cattle infected with EHEC O157:H7 can remain asymptomatic although they still shed the bacteria into the environment through their feces. Environmental contamination with EHEC O157:H7 caused by infected cattle has been increasingly reported in the last 10 years (Fremaux, Prigent-Combaret et al. 2008). Infected cattle can contaminate drinking water sources, soil, and vegetables. Epidemiological studies also confirmed that a variety of bovine products such as ground beef, roast beef, and raw dairy products can cause EHEC O157:H7 infections in humans.

### 1.3. EHEC and Cattle

Although EHEC O157:H7 can colonize a number of different species, including sheep, dogs, some birds, and some wild animals, beef and dairy cattle are still considered the major reservoir for infection risk to humans (Griffin and Tauxe 1991; Armstrong, Hollingsworth et al. 1996; LeJeune, Besser et al. 2001).

Cattle can carry EHEC O157:H7 for different lengths of time (Lim, Yoon et al. 2010). Cattle can be colonized by EHEC O157:H7 at the terminal rectum mucosa and shed the bacteria for 3-12 months or even longer. Different factors such as age, diet and immunity play roles in the shedding time frame. EHEC O157:H7 is more frequently isolated from cattle during warmer months of late summer and early fall, and not surprisingly, this is the season when the most human infections take place (Armstrong, Hollingsworth et al. 1996; Elder, Keen et al. 2000). Shedding of the bacteria by cattle for more than 12 months is a long period of time. This extended period of colonization in cattle can increase bacterial contamination of the environment, beef related products, and the other cattle in the herd that are not colonized by the bacteria.

EHEC O157:H7 can easily be spread by the carrier cattle. Although ground beef is the main route for the infection in humans, cattle manure containing EHEC O157:H7 can be washed into the water supply and thus may contaminate water used for drinking, crop irrigation, vegetable and fruit production, and be transmitted to other animals that act as vectors. In fact, numerous EHEC O157:H7 outbreaks in humans have been associated with the consumption of vegetables such as lettuce, radishes, alfalfa sprouts, and spinach (Fukushima, Hashizume et al. 1999; Ferguson, Scheftel et al. 2005; Maki 2006). Based on all this knowledge, some investigators stated that strategies that control the EHEC O157:H7 before it enters into the food chain would greatly decrease environmental contamination (Hancock, Besser et al. 2001). In particular, preventing or reducing EHEC O157:H7 colonization of cattle intestine, perhaps by vaccination, could result in a

decreased potential for environmental contaminations as well as lower the risks for contamination of beef and dairy products. Therefore, vaccination of cattle has the potential to decrease EHEC O157:H7 infections in humans.

#### 1.4. Virulence Factors of EHEC O157:H7

##### 1.4.1. Locus of Enterocyte Effacement

The locus of enterocyte effacement (LEE) is an approximately 43 kb pathogenicity island found in EPEC and EHEC. EPEC has a smaller LEE region than EHEC that is approximately 35 kb (Yoon and Hovde 2008). The LEE region includes three different sections that encode five different operons. LEE1, LEE2, and LEE3 operons encode the genes responsible for type three secretion systems (TTSS). The second section includes the LEE5 operon which encodes the genes responsible for bacterial adhesion, intimin and translocated intimin receptor (Tir). The third section includes the LEE4 operon that encodes the genes for *E. coli* secreted proteins, for example, EspA, EspB and EspD.

##### 1.4.2. Intimin

Intimin or Eae (*E. coli* attaching and effacing protein) is a 94kDa outer membrane protein that mediates intimate attachment of the bacteria to the host epithelial cell (Donnenberg, Tzipori et al. 1993). This intimate attachment can cause attachment and effacement (A/E) lesion formation on the host intestinal epithelium (Donnenberg, Tzipori et al. 1993). A/E lesion formation was first described in EPEC (Jerse, Yu et al. 1990; Jerse and Kaper 1991) and it is characterized by

adherence of the bacteria to the intestinal epithelium cells and damage to microvilli on them. It also causes pedestal-like formation by the accumulation of actins in the epithelial cell underneath the attached bacteria. A/E lesion formation disrupts the tight junctions and causes diarrhea (Agin, Zhu et al. 2005; Guttman, Li et al. 2006). Frankel, Candy et al., (Frankel, Candy et al. 1994; Frankel, Candy et al. 1995) showed that the highly divergent C-terminal region of the intimin binds to its receptor, Tir. After Tir is translocated into the host cells by the type III secretion system, it incorporates itself into the intestinal epithelium with its intimin binding domain displayed on the intestinal cell surface. Subsequently, close interaction between intimin and Tir recruit actin within the epithelial cells and leads to A/E lesion formation. Although the most severe cases of infection are due to the production of Shiga toxin, close association of the bacteria and the forming of an A/E lesion is the beginning of the bacterial colonization and Shiga toxin release.

In addition to the intimin/Tir interaction, intimin can interact with a host cell surface protein called nucleolin (Sinclair and O'Brien 2002). Both Tir and nucleolin bind to the carboxy-terminal domain of intimin (Frankel, Candy et al. 1994; Frankel, Candy et al. 1995; Sinclair and O'Brien 2002). Based on these observations we can conclude that the carboxy-terminal domain of intimin is very important in the intimin host-cell interaction.

Since the intimin is an important adherence factor for *E. coli* O157:H7, a vaccine designed target intimin in order to block the intestinal adherence of the bacteria is feasible. Furthermore, antibodies specific to intimin can block adherence of

bacteria to cultured cells and intestinal mucosa (Gansheroff, Wachtel et al. 1999; Dean-Nystrom, Gansheroff et al. 2002). This is a strong indication that intimin is an attractive candidate for the development of an EHEC O157:H7 vaccine. Thus, a variety of approaches are being studied as possible vaccination strategies including plant-derived vaccines (Judge, Mason et al. 2004).

#### 1.4.3. The pO157

The pO157 is a large plasmid which varies from 92 Kb to 104 Kb and it is contained by most of the EHEC O157:H7 strains. The complete sequence of this plasmid was published in 1998, where it was explained that there are 100 open reading frames (ORFs) (Burland, Shao et al. 1998; Makino, Ishii et al. 1998). Presumably, 32 proteins are involved in the pathogenesis of *E. coli* O157:H7. Since pO157 encodes potential virulence factors such as hemolysin (ehx), catalase peroxidase (katP), and a serine protease, it may play an important role in the pathogenesis of EHEC. However the role of pO157 in the pathogenesis of *E. coli* O157:H7 is not fully understood.

#### 1.4.4. Shiga toxin

Shiga toxins (Stx) are produced by enteric pathogens such as *S. dysenteriae* serotype 1 and EHEC. In the 1890s after an epidemic in Japan, *S. dysenteriae* (Shiga's bacillus) serotype 1 was described by Kioshi Shiga (Shiga 1898; Trofa, Ueno-Olsen et al. 1999). In 1903, shortly after this discovery, Conradi described that an extract from the Shiga's bacillus paralyzed and killed rabbits (Conradi,

1902:). A similar finding was independently reported by Neisser and Shiga (Neisser and Shiga, 1903). In the mid 1970s the toxin was characterized in more detail by different groups (Keusch and Jacewicz 1975; O'Brien, Thompson et al. 1977) and in 1977 O'Brien and colleagues reported that certain strains of *E. coli* produce a toxin that can be neutralized by anti-Stx (O'Brien, Thompson et al. 1977). Since then this specific toxin from *E. coli* was called Shiga-like toxin. In the same year, Konowalchuk (Konowalchuk, Speirs et al. 1977) reported that certain diarrheagenic *E. coli* produces a toxin called Vero toxin, which can kill Vero (African green monkey kidney) cells. In 1983, O'Brien et al (O'Brien, Lively et al. 1983) reported that Shiga-like toxin produced by *E. coli* O157:H7 was responsible for causing an outbreak in the United States, and that this Shiga-like toxin was the same as Vero toxin. Although some researchers use the name "Shiga toxin" for the *E. coli* O157:H7 toxin, some still use either "Shiga-like toxin" or "Vero toxin" for Shiga toxins from *E. coli* O157:H7. In this work I will use the term "Shiga toxin" (Stx).

There are two main types of Shiga toxins associated with Shiga toxin-producing *E. coli* (STEC): Shiga toxin 1 (Stx1) and Shiga toxin 2 (Stx2). Stx1 differs from the toxin produced by *S. dysenteriae* type 1 by only one amino acid in the A polypeptide (O'Loughlin and Robins-Browne 2001). On the other hand, Stx1 and Stx2 share approximately 56% identity at the amino acid sequence level (Johannes and Romer 2010). STEC can also produce Stx1 and variants (Stx1b and Stx1c), Stx2 variants (Stx2c, Stx2d, Stx2e and Stx2f) or combinations of different variants.

Stx is one of the major virulence factors of EHEC, and belongs to the AB5 toxin family consisting of an A subunit (32kDa) and five identical B subunits (7.7kDa). The A subunit is composed of a 27kDa enzymatically active A1 subunit and a 5kDa structural A2 subunit. The A1 subunit has N-glycosidase activity and it cleaves a single adenine residue from the 28S ribosomal RNA of the 60S ribosome. After the depurination step, peptide elongation stops, since elongation factor 1-dependent aminoacyl transfer RNA is inhibited (Cherla, Lee et al. 2003). The A2 subunit associates with the A1 subunit via a disulfide bond and it links the A1 subunit to the B subunit pentamers by noncovalent associations (O'Loughlin and Robins-Browne 2001; Lim, Yoon et al. 2010). In addition, the B subunit of Shiga toxin (StxB) pentamer binds to its receptor, the globotriaosylceramide (Gb3), with the exception of Stx2eB which binds to Gb4 instead of Gb3.

### 1.5. Shiga toxin and the HUS

In 1955, HUS was described by Gasser and colleagues (Gasser, Gautier et al. 1955), who reported a serious case of five children with hemolytic anemia, thrombocytopenia (low platelet count), and small vessel renal thrombi (Gasser, Gautier et al. 1955). However, the key association between an *E. coli* O157:H7 infection and the HUS was discovered by Karmali *et al.* in 1983 (Karmali, Petric et al. 1983), who reported sporadic cases of HUS associated with an *E. coli* toxin, and they realized this toxin was lethal to cultured Vero cells. A week after this report, Riley described two clusters of patients with bloody diarrhea, and also reported a linkage between this event and undercooked hamburgers. Many of the



patients in these clusters had *E. coli* O157:H7 in their stools. (Riley, Remis et al. 1983) Shortly after, O'Brien and co-workers reported an association between *E. coli* O157:H7 toxin and the toxin of *S. dysenteriae* serotype 1 (O'Brien, Lively et al. 1983).

Renal injury in D+HUS is caused by Stx. After ingesting the food contaminated with *E. coli* O157:H7, bacteria passes through the acidic stomach environment and attaches to the intestinal epithelial cells (Bielaszewska and Karch 2005). Then Stx is translocated across the intestinal epithelium into circulation by binding the polymorphonuclear leukocytes. When Stx arrives at target organs, it binds to Gb3 molecules displayed on the target cell surface via its B subunit and increases cytokine expression which in return damage the target cells (Ray and Liu 2001).

## 1.6 Diagnosis

The very first selective medium for screening and isolation of *E. coli* O157:H7 was the sorbitol MacConkey agar (SMAC). If there is a possibility that a patient is infected with EHEC O157:H7, a stool specimen is collected and tested for the organism. The number of excreted pathogens per gram of feces rapidly decreases in a few days after infection. Hence, stool samples should be obtained and tested as soon as possible. Early in the course of the disease, samples are plated on SMAC, which contains 1% sorbitol instead of 1% lactose. Since EHEC O157:H7 is unable to ferment sorbitol rapidly; it forms colorless colonies on SMAC. Therefore, it can be distinguished from most of the remaining intestinal *E. coli* strains that ferment sorbitol and form pink colonies (Mead and Griffin 1998;

Karch, Bielaszewska et al. 1999; Kehl 2002). Other tests can also be done to identify EHEC O157:H7 (Ochoa and Cleary 2003). Enzyme-linked immunoassay (ELISA) kits are available for fast screening of fecal samples containing the O157 antigens. The ELISA test is more sensitive compared to SMAC, but it only detects *E. coli* O157. PCR assays are also used to detect *E. coli* O157:H7 major virulence genes. PCR assays are commonly based on Stx genes and EHEC O157:H7 specific *eae* (intimin) DNA sequences (Bai, Shi et al. 2010). Positive results by ELISA or PCR assay should also be confirmed by culture.

#### 1.7. Recombinant Subunit Vaccines

Infectious diseases cause a 45% mortality in low-income countries (Arntzen, Plotkin et al. 2005), and it is well known that vaccines are the most effective way of combating infectious diseases both in humans and animals. Traditional vaccines consist of live, killed, or attenuated pathogens. However the attenuated pathogen used as a vaccine can cause severe disease in immunosuppressed individuals, such as people suffering from HIV/AIDS or malnutrition. On the other hand, recombinant vaccines can offer safer options for both healthy and immunosuppressed individuals, since no pathogens are involved (Yusibov and Rabindran 2008).

In the past 30 years, there have been many different approaches applied for vaccine development and manufacturing, although innovative and new methods are still in demand. Recombinant subunit vaccines can be produced in different hosts including *E. coli*, yeast, mammalian cells, insect cells, and plants. For

recombinant antigen expression, the gene that encodes a protective antigen is expressed in the host, and the resulting recombinant protein is purified and administered as a vaccine. Each type of host has some advantages and some challenges to overcome. For example, the vaccines produced in *E. coli* can contain endotoxins and other unwanted pyrogens. In addition, complex proteins produced in *E. coli* will not undergo some eukaryote-specific post-translational modifications (Choi and Lee 2004). Nonetheless, recombinant proteins produced in bacteria offer the advantages of low cost, high scale up capacity, and short production timescale. The yeast expression system has some similarities to the bacterial expression system, including the use of relatively inexpensive growth medium and the high scale-up capacity. Yeast expression has one great advantage over bacterial expression: yeast is able to fold and assemble complex eukaryotic proteins. However, protein glycosylation can be incorrect, since the yeast glycan structure is different than those found in mammalian cells (Romanos, Scorer et al. 1992).

Mammalian cells are another alternative for subunit vaccine production. Although complex recombinant proteins can fold correctly, the maintenance of mammalian cells is very costly and it is hard to scale up. An additional disadvantage of the mammalian cells system for subunit vaccine production is that they can carry oncogenic agents and pathogens. The insect cell system shares some of the disadvantages of mammalian cells for the production of subunit vaccines.

Plant expression systems are an alternative to the other systems discussed above and are emerging as an economical substitute for fermentation-based expression

systems for producing of subunit vaccines (Mason and Arntzen 1995; Sojikul, Buehner et al. 2003; Mor, Mason et al. 2004). Plant derived recombinant vaccines offer some advantages over the traditional vaccines, including lower production cost and higher production volume, speedy scalability, higher safety (free of human pathogens), and ability to assemble complex eukaryotic proteins (Ma, Drake et al. 2003; Thanavala, Huang et al. 2006). As in mammalian cell expression systems, complex recombinant proteins expressed in plants can fold correctly and undergo post-translational modification. However, unlike the mammalian cell system the plant expression system does not require the manufacturing and operation of expensive fermenters, employment of highly skilled workers and use of costly culture media (Yusibov and Rabindran 2008). In addition, plants can be grown locally using inexpensive traditional agriculture (Goldstein and Thomas 2004).

Since plant-derived vaccines were first described by Mason et al. (Mason, Lam et al. 1992) different research groups all over the world began to investigate the use of plants for vaccine development and today there is a long list of recombinant proteins produced in a variety of plant systems (Mason, Warzecha et al. 2002; Ma, Drake et al. 2003; Tiwari, Verma et al. 2009). Although there are many different types of plants have been used as hosts for production of plant derived vaccines, tomato has some advantages over the other plant hosts. The culture of tomatoes is relatively simple and well established, and tomato plants have a high biomass fruit yield, approximately 68,000 kg per hectare (Ma, Drake et al. 2003; Alvarez and Cardineau 2010). The fact that tomato produces an edible fruit is

another advantage for the use of this plant as a plant derived vaccine production host, particularly for the development of orally-delivered vaccines. The short shelf-life of the fresh tomato fruit can be overcome by freeze-drying and pulverizing the fruits (Rigano and Walmsley 2005).

To conclude, vaccine production in plants has now been proven to be successful. In addition, several successful human clinical trials accomplished with plant-made vaccines have shown the potential of using this technology for vaccine production (Tacket, Mason et al. 1998; Kapusta, Modelska et al. 1999; Yusibov, Hooper et al. 2002; Tacket, Pasetti et al. 2004; Thanavala, Mahoney et al. 2005; Thanavala, Huang et al. 2006).

After taking into consideration of all the reasons previously stated, we decided to use the plant system to develop a vaccine candidate to prevent *E. coli* O157:H7 intestinal attachment in cattle. We expressed the carboxy-terminal one-third of intimin protein in tomato plants and demonstrated that this plant-derived vaccine candidate was immunogenic in mice. We also used bacteria for expression of vaccine antigens. We expressed StxB1, carboxy-terminal third of intimin (IntC) and StxB1-IntC fusion protein in bacteria and we confirmed the immunogenicity of them in mice.

#### 1.8. Specific aims of the dissertation

One of the hypotheses proposed in this dissertation is that when the C-terminal domain of the intimin protein is expressed in plants and used to immunize animals, a specific immune response will be induced. We hypothesized that

immunized animals infected with EHEC O157:H7 will have a decreased duration of intestinal colonization by this bacteria.

A second hypothesis is that mice immunized with purified StxB1-IntC fusion protein expressed in *E. coli* will produce stronger immune responses than mice immunized with either purified IntC or StxB1 alone. To test these hypotheses, I pursued the following steps. First, I successfully expressed IntC protein in tomato plants to be used as antigen in animal immunizations. Second, I purified the IntC expressed in two different expression systems: bacteria and plants. Third, I expressed StxB1-IntC fusion protein in bacteria and purified the protein. Fourth, I tested the immunogenicity of the purified antigens in mice before challenging them with EHEC O157:H7 to evaluate the duration of bacterial shedding.

## Chapter 2

### PLANT DERIVED VACCINE TO PREVENT *ESHERICHIA COLI* O157:H7 INTESTINAL ATTACHMENT

#### Abstract

In the United states, *Escherichia coli* serotype O157:H7 (*E. coli* O157:H7) is the most common cause of hemolytic uremic syndrome in humans and the most common reason for kidney failure in children (Dean-Nystrom, Gansheroff et al. 2002). Although different wild and farm animals can carry and spread *E. coli* O157:H7, cattle are the major reservoir of this serotype. *E. coli* O157:H7 infections in humans take place after ingestion of contaminated meat or dairy product originating from cattle. Since the bacterial protein intimin plays a major role in colonization, blocking this protein would prevent the intimate bacterial attachment to the host, leading to a reduced bacterial colonization in the cattle and it would limit *E. coli* O157:H7 infection in humans. In this research, we used intimin as a candidate vaccine to prevent *E. coli* O157:H7 colonization in the host by blocking the intestinal attachment. We expressed the C-terminal domain of intimin in transgenic tomato and we purified it using nickel affinity chromatography. We used this purified intimin to immunize the mice. We demonstrated mice immunized mucosally with tomato-derived IntC cleared *E. coli* O157:H7 from their intestines significantly faster than those mice in other groups. This is a very first step towards the development of a vaccine for cattle that will reduce their infection by *E. coli* O157:H7, and thus limit the incidence of human infections as well.

## 1. Introduction

*Escherichia coli*, especially serotype O157:H7, is a main cause of diseases including uncomplicated diarrhea, bloody diarrhea, hemorrhagic colitis, and severe hemolytic uremic syndrome (HUS) in humans world wide (Sheng, Lim et al. 2006). HUS induced by *E. coli* O157:H7 is the most common cause of acute kidney failure in children in the United States. However, the disease caused by O157:H7 bacteria is not limited to children, since all age groups can be easily infected (Gary Reiss 2006; (Reiss, Kunz et al. 2006). In the United States, 73,480 infections, and 61 deaths occur per year (Mead, Slutsker et al. 1999; Yoon and Hovde 2008) and the cost of the infections can be up to \$3.3 billion dollars annually (Frenzen, Drake et al. 2005).

There are three main pathways for *E. coli* O157:H7 infections: food-borne, environmental, and person-to-person contact (Strachan, Dunn et al. 2006). Ruminant feces are the most common contaminants for the food-borne and environmental route. Although different kinds of ruminants can carry *E. coli* O157:H7, cattle are the major reservoir for infections in humans (Dean-Nystrom, Gansheroff et al. 2002; Judge, Mason et al. 2004; Sheng, Lim et al. 2006; Fremaux, Prigent-Combaret et al. 2008; Serna and Boedeker 2008). The *E. coli* O157:H7 infected cattle are a direct source of contaminated meat and dairy products, as well as an indirect source by the fecal contamination of soil, water, and vegetables(Fremaux, Prigent-Combaret et al. 2008). Dairy products and meat can be contaminated with cattle feces during milking and slaughtering. *E. coli* O157:H7 can survive in very diverse environments including soil, sewage,



different water systems, various acidic environments, and the gastrointestinal tract (Avery, Williams et al. 2008; Yoon and Hovde 2008). It has been shown that *E. coli* O157:H7 can survive in manure or in drinking troughs for months or years and still be able to colonize cattle, resulting in re-contamination of the surroundings (LeJeune, Besser et al. 2001; Avery, Williams et al. 2008).

Environmental contamination by cattle was the case in the recent multi-state outbreak of *E. coli* O157:H7 infections from spinach, which resulted in 199 infections, 31 cases of HUS, and 3 deaths (Center for Disease and Control Prevention, 2006). Contamination with *E. coli* in meat products decreased in recent years because of the higher safety standards of in the meat industry.

However, the recent large multi-state *E. coli* O157:H7 outbreaks caused by the ingestion of infected spinach showed that a prevention of these infections is urgently needed.

Preventing the infection is extremely important, because antibiotic treatments after the infection are unreliable. There are some conflicting results on antibiotic usage in cases of HUS caused by *E. coli* O157:H7. Unfortunately, according to some studies, antibiotic treatment can increase the risk of HUS (Wong, Jelacic et al. 2000; Safdar, Said et al. 2002; Ochoa and Cleary 2003), and does not improve the outcome of the disease (Scheiring, Andreoli et al. 2008).

One of the best strategies to reduce infection with *E. coli* O157:H7 in humans is to prevent bacterial colonization in cattle. This strategy is very well accepted by many researchers (Dean-Nystrom, Gansheroff et al. 2002; Judge, Mason et al. 2004; Cataldi, Yevsa et al. 2008), who believe that it would reduce the incidence

of infection in humans by preventing bacterial colonization of cattle, and therefore, reducing food-borne and environmental contamination with *E. coli* O157:H7.

Intimin is an *E. coli* O157:H7 outer membrane protein that is required for intimate attachment of the bacteria to the host cells and essential for attaching and effacing lesion (A/E lesion) formation (Donnenberg, Tzipori et al. 1993; McKee, Melton-Celsa et al. 1995; McKee and O'Brien 1996; Dean-Nystrom, Bosworth et al. 1998; Batchelor, Prasanna et al. 2000). A/E lesions are characterized by the destruction (effacement) of brush border microvilli, intimate adherence of the bacteria to the host cell, and cytoskeletal rearrangement of the host cell resulting in a pedestal like formation underneath the bacterial attachment (Moon, Whipp et al. 1983; Nataro and Kaper 1998). Based on that knowledge, we propose that antibodies against intimin could inhibit or prevent bacterial attachment in the host. Hence, intimin is a very promising vaccine candidate that could reduce O157:H7 colonization in cattle. It has also been shown that suckling piglets were protected from colonization with EHEC O157:H7 by ingesting colostrum from intimin-vaccinated dams (Dean-Nystrom, Gansheroff et al. 2002). Judge et. al. (Judge, Mason et al. 2004) demonstrated that mice primed with plant-derived intimin C-terminal domain (IntC) and orally boosted with plant-derived IntC showed a decrease in bacterial shedding in their feces after they were challenged with *E. coli* O157:H7. Cataldi et al. (2008), demonstrated that intimin is a good potential vaccine candidate. These examples provide evidence that vaccination with intimin

is a potential strategy for prevention of *E. coli* O157:H7 colonization in cattle. Hence, we used the *E. coli* O157:H7 intimin protein as a vaccine candidate. Since Mason et al. (Mason, Lam et al. 1992) reported the expression of hepatitis B surface antigen different research groups all over the world began to investigate the use of plants for potential vaccine development, and vaccine production in plants has now shown a great potential (Haq, Mason et al. 1995; Mason, Ball et al. 1996; Mason, Haq et al. 1998; Tacket, Mason et al. 1998; Tacket and Mason 1999; Judge, Mason et al. 2004; Alvarez, Pinyerd et al. 2006; Wen, Teel et al. 2006b). Plant expression systems offer several advantages compared to other expression systems, including lower risk of contamination with human pathogens, larger scaling up capacity, cost-effective production (Thanavala, Huang et al. 2006; Mestecky, Nguyen et al. 2008). In addition, the several human clinical trials accomplished with oral delivery of plant-made vaccines have shown the potential of using the plant-made vaccine technology (Tacket, Mason et al. 1998; Kapusta, Modelska et al. 1999; Yusibov, Hooper et al. 2002; Tacket, Pasetti et al. 2004). Thus, we developed a candidate plant-derived vaccine to prevent *E. coli* O157:H7 intestinal attachment by expressing the IntC protein in tomato plants, and showed that it was immunogenic in mice.

## 2. Materials and methods

### 2.1 Plasmids

Tomato plants were transformed using plasmids pNR49 and pNR50 (Judge, Mason et al. 2004). pNR49 contains a plant-optimized C-terminal 281 amino

acids of intimin from *E. coli* O157:H7 strain 86-24 (Genbank Z11541) with a 6-His tag added at the N-terminus, and the soybean vspA N-terminal signal peptide sequence obtained from plasmid pBTI210.4. The construct was reported to contain the C-terminal 281 amino acids of intimin (Judge, Mason et al. 2004), but our sequencing showed that it actually contains 281 intimin residues. pNR50 (Judge, Mason et al. 2004) is similar to plasmid pNR49 except that does not contain a signal peptide (Fig. 1).

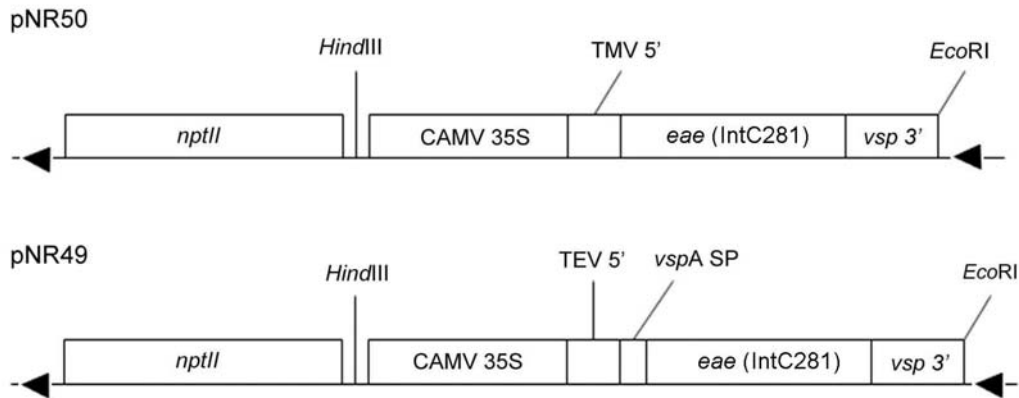

Figure 1. IntC expression constructs pNR49 and pNR50 were used for recombinant protein expression in tomato plants. The CaMV 35S promoter and soybean *vspB* 3' region flank the IntC coding sequence. Neomycin phosphotransferase II used to express kanamycin resistance in transgenic plants. The VspA signal peptide from soybean vegetative storage protein A was incorporated in pNR49 in order to increase protein expression.

## 2.2 Stable transformation of tomato

The *Agrobacterium*-mediated transformation protocol was modified from Walmsley et al. (Walmsley, Alvarez et al. 2003). Tomato cotyledons from *Lycopersicon esculentum* variety Tanksley TA234 was used for stable transformation. Tomato seeds were first sterilized in 20% Clorox (Commercial bleach, active ingredient is 5.25% NaOCl) for 20 minutes and rinsed with sterile distilled water three times. After sterilization, seeds were placed on half-strength Murashige and Skoog (MS) medium (50 mg/l myo-inositol, 2 mg/l thiamine HCL, 0.5 mg/l pyridoxine HCL, 0.5 mg/l nicotinic acid, 10 g/l sucrose, 8 g/l Difco bacto agar, pH 5.8) and left to germinate. Cotyledons were excised from germinated seedlings before the first true leaves appeared. Cotyledons were cut into small squares (approximately 1 cm<sup>2</sup>) and incubated in a suspension of *Agrobacterium tumefaciens* LBA4404 containing a binary vector, either pNR49 or pNR50, for 10 minutes on a shaker at room temperature. Cotyledon explants were then transferred with adaxial side up into 2Z selection medium (4.3 g/l MS salts, 20 g/l sucrose, 100 mg/l myo-inositol, 2 mg/l glycine, 10 mg/l nicotinic acid, 0.5 mg/l pyridoxine HCL, 0.5 g/l thiamine HCL, 0.5 mg/l folic acid, 0.5 mg/l d-biotin, 5.2 g/l agar, 300 mg/l timentin, 100 mg/l kanamycin, pH 5.8-6) . Cotyledon explants were transferred to 2Z selection medium every three weeks until shoots began to appear. Shoots were then excised and transferred to rooting medium (4.3 g/l MS salts, 30 g/l sucrose, 2 mg/l glycine, 10 mg/l nicotinic acid, 0.5 mg/l pyridoxine HCL, 0.5 g/l thiamine HCL, 0.5 mg/l folic acid, 0.5 mg/l d-biotin, 8 g/l bacto-agar, 300 mg/l timentin, 100 mg/l kanamycin, pH 5.8-6)

### 2.3 Protein extraction from fresh leaves, fresh fruits and freeze- dried fruits

Approximately 300 mg fresh leaves or fresh fruit were placed into 2 ml Fastprep® tubes (Fisher Scientific, PA) and frozen in liquid nitrogen. Approximately 0.03 mg of pulverized freeze-dried tomato fruit was placed into 2 ml Fastprep® tubes. All of the samples were suspended in 1 ml extraction buffer (100mM Tris pH8, 100mM NaCl, 1mM EDTA, 0.01% Triton X-100, 10µg/ml leupeptin) and homogenized in a Fastprep® machine (FP120 BIO101 Savant, Lab Central B.V., Haarlem, The Netherlands) for 40 seconds at speed 4. The samples were centrifuged at 20,000xg for 30 minutes at 4°C, and the supernatants transferred to clean 1.5 ml tubes and tested by Bradford assay (Bradford 1976) for total protein using bovine serum albumin (BSA) as the reference standard, and tested for intimin expression (below).

### 2.4. Enzyme-linked immunosorbent assay (ELISA) for intimin

The expression of IntC protein in transgenic tomato plants was measured by ELISA. All antibodies were diluted in 1% dry milk (DM) in phosphate buffer saline (PBS) containing 0.05% Tween 20 (1% DM /PBST), except the goat anti-intimin antibody, which was diluted in PBS. High binding polystyrene EIA/RIA 96 well micro plates (Corning, NY) were incubated with goat anti-intimin antibody (Kindly provided by Dr. Alison O'Brien) diluted 1:3000 for 2 hours at 37°C. ELISA plates were washed three times with PBST and blocked with 5% dry milk/PBST overnight at 4°C. The next day, the ELISA plates were washed three

times with PBST. Dilutions of bacterial intimin (Kindly provided by Dr. Alison O'Brien) and plant extracts were diluted in 1% DM/PBST, added to the plates, and incubated for 2 hours at 37°C. Following three washes with PBST, the plates were incubated with rabbit anti-intimin antibody at a 1:5000 dilution, for 2 hours at 37°C. Following three washes with PBST, horseradish peroxidase (HRP) labeled goat anti-rabbit antibody (1:10000 dilution) was added to the wells, and the plates were incubated for 1 hour at 37°C. The HRP substrate in the ECL Plus kit (Amersham Biosciences, Piscataway, NJ) was used to develop color as per the manufacturer's instructions. The optical densities at 450nm (OD<sub>450</sub>) of the samples were read on a microtiter plate reader (MRX-tc, Dynex technologies, Chantilly, VA).

A standard curve was generated from the bacterial intimin reference standard readings, and used to calculate the IntC concentration in the plant samples.

## 2.5. Western blot analysis

The protein extracts were obtained as it was described in section 2.3. The content of total soluble proteins (TSP) was calculated using Bradford assay (Bio-Rad, Hercules, CA), using BSA as the reference standard. Equal amounts of TSP from each plant extract was calculated and 6x SDS gel loading buffer (300mM Tris-HCl, pH 6.8, 600mM dithiothreitol, 12% SDS, 0.6% bromophenol blue, 60% glycerol) was added to the samples before boiling them for 15 minutes and placing them on ice. Samples were centrifuged for 5 seconds at 16,000xg and loaded into a precast SDS polyacrylamid gel (Bio-Rad, 12% Tris-HCl separating,



4% stacking). The gel was run at 35mA for 2 hours using a Tris-glycine running buffer (25mM Tris, 250mM glycine and 0.1% SDS), and the proteins were electrotransferred onto a PVDF membrane at 80V for 2 hours. The membrane was blocked overnight at 4°C, and the following day it was blocked in 5% DM/PBST on a shaker at room temperature. The membrane was washed six times in PBST for 15 minutes each, and then incubated with rabbit polyclonal antibody against intimin (kindly provide by Dr. Alison O'Brien) diluted 1:8000 in 1% DM/ PBST for 1 hour at 37°C . The membrane was washed four times in PBST for 15 minutes each, and then incubated with HRP conjugated goat polyclonal anti-rabbit IgG (Sigma-Aldrich, Saint Louis, MO) at a 1:10000 dilution in 1% DM/ PBST. The ECL plus kit (Amersham Biosciences, Piscataway, NJ) was used to detect the specific protein according to the manufacturer's instructions. Purified bacterial purified intimin (kindly provide by Dr. Alison O'Brien) was used as a positive control and a wild type tomato plant extract as a negative control.

## 2.6. Tomato fruit processing for animal trials

Freshly collected tomato fruits from the same plant were pooled and kept at -20°C. Frozen fruits were cut into small pieces using a deli- slicer and then freeze-dried using a FreeZone Freeze Dry system (Labconco) for at least 4 days. Freeze-dried fruits were ground into a powder, vacuum-sealed in plastic with a vacuum food sealer and stored at room temperature or collected in 50 ml conical tubes and saved at room temperature.

## 2.7. Protein purification from freeze-dried fruits

Approximately, 5 g of freeze-dried powdered red tomatoes were slowly placed into a cold mortar containing liquid nitrogen and the mixture was ground until a fine powder was obtained. 50 ml extraction buffer (20mM sodium phosphate, 0.5M sodium chloride, 10 µg/ml leupeptin and 10mM imidazole) was added to the fine powder, transferred into a 50ml tube and centrifuged at 10000xg for 45 minutes. The supernatant was transferred to a clean 50 ml tube and the centrifugation step repeated. Finally, the supernatant was filtered through a membrane and added to a His Trap Hp Column (GE Healthcare life Sciences, Piscataway, NJ) according to the manufacturer's instructions.

## 2.8 Deglycosylation of purified IntC from tomato fruit

Purified His-tagged IntC from freeze-dried tomato fruit was treated with trifluoromethanesulfonic acid (TFMS) (Prozyme, Hayward, CA) and PNGase F, PNGase A, and Endo H (New England Biolabs, Ipswich, MA) according to manufacturer's instruction. Purified plant-derived Intimin and bacterial-derived Intimin were denatured in Glycoprotein Denaturing Buffer (0.5% SDS, 40mM dithiothreitol) at 100 °C for 15 min. Samples were centrifuged at 2,000 × g for 1 min, and the supernatant was used for endoglycosidase digestions. Approximately 10µg of the denatured bacterial- and plant-derived Intimin was digested with PNGase F (1000 U) or Endo H (2000 U) at 37 °C for 3 h. The samples were then analyzed by Western blotting.

## 2.9. Animal immunization

Twenty-four-week-old female BALB/c mice were separated into three different groups of six animals each. On day 0, all the mice were primed intraperitoneally (IP) with 0.5µg purified bacterially derived IntC (See chapter 3), including the negative control mice (group 1). TiterMax Gold (TiterMax, GA) was used as an adjuvant according to the manufacturer's instructions. On week 3, the mice in group 2 were boosted intranasally (IN, mice held by their scruff and 5µl of PBS containing purified intimin was delivered to each nostril) with 4µg of tomato-derived IntC supplemented with 10µg of cholera toxin (CT, Sigma-Aldrich, Saint Louis, MO) as an adjuvant, and the mice in group 3 (positive control) were boosted IP with 0.5µg tomato-derived IntC supplemented with TiterMax Gold. The mice in group 2 were boosted again at weeks 7 and 14 with IN delivery of 4 and 30µg of tomato-derived IntC supplemented with 10µg CT, respectively. The mice in group 3 were boosted IP with 0.5µg tomato-derived IntC supplemented with TiterMax Gold at week 7. Blood samples were collected from the submandibular vein and incubated at room temperature for 10 minutes to let the blood coagulate, and centrifuged at 3000xg for 10 minutes. The sera were transferred to clean tubes and saved at -20°C until samples were tested by ELISA. Fecal pellets and vaginal lavages were also collected from individually housed mice and saved at -20°C until they were tested by ELISA to detect specific IgA titers. Proteins were extracted from fecal pellets using 1ml extraction buffer (10µg/ml leupeptin, 0.1% Tween 20 in PBS) per 100mg of fecal pellets. Samples were first kept at 4°C for 20 minutes before a 1 min homogenization by Bullet

Blender homogenizer (Next Advance Inc., Averill Park, NY). Homogenized samples were centrifuged at 20,800xg in an Eppendorf microcentrifuge 5417R (Eppendorf, Hauppauge, NY) for 10 minutes at 4°C. The cleared supernatants were collected and analyzed by ELISA. Vaginal lavage (vaginal opening of the mice were washed using round needle and syringe) samples were mix very well by vortexing and centrifuged in an Eppendorf Microcentrifuge 5417R at 17900xg for 10 minutes at 4°C.

#### 2.10. ELISA to determine IgG1 and IgG2 titers in mouse serum, and IgA titer in feces and vaginal lavages

ELISA was used to measure antigen-specific antibody titers in the biological samples. High binding polystyrene EIA/RIA 96-well microplates (Corning, Glendale, AZ) were coated with 50ng bacterial IntC protein (purified in our laboratory) in PBS. Plates were then incubated at room temperature for 4h and then overnight at 4°C. On the following day, plates were washed with PBST (PBS pH 7.4 with 0.05% Tween-20) and then blocked with 5% skim milk in PBST (5% PBST) for 1 h at 37°C. After another three washes with PBST, sera were serially diluted two-fold in the ELISA plate and incubated for 1 h at 37°C. Plates were washed three times with PBST, before incubation with HRP-conjugated goat anti-mouse IgG1 at dilution 1:2,500 in 1% PBST for IgG1 detection, or goat anti-mouse IgG2a at dilution 1:2,500 in 1% DM/ PBST for IgG2a detection. For detection of IgA in fecal extracts and vaginal lavages, HRP-conjugated goat anti-mouse IgA was used at dilution 1:1,000 in 1% DM PBST. Plates were washed

three times with PBST and the color developed with TMB peroxidase substrate (Bio-Rad, Hercules, CA). The enzymatic reaction was stopped with 1N H<sub>2</sub>SO<sub>4</sub> and the absorbance was read at 450nm in an Elisa plate reader (MRX-tc, Dynex technologies, Chantilly, VA). Titers were calculated as the highest dilution factor of the serum that produced an absorbance reading of 0.1 at 450nm after subtracting non-specific absorbance reading from non-treated mice.

### 2.11. Bacterial Challenge

Two weeks after the last boost, mice were fasted overnight and the water was removed from the cages 4 hours prior to the bacterial administration.

Streptomycin resistant EHEC O157:H7 strain 86-24 Str<sup>r</sup> (Melton-Celsa, Rogers et al. 1998) was plated one night before 2-3 colonies were selected to prepare a liquid culture. Twenty-five ml of LB culture containing 100µg/ml streptomycin was shaken at 37°C for 3 hours. The bacterial culture was centrifuged and re-suspended with freshly prepared, filter-sterilized 2.5 ml of 20% sucrose. A total of two doses were administered 4 hours apart and in each dose mice were fed with 10<sup>8</sup>-10<sup>9</sup> colony forming units (CFU) of bacteria. Following the challenge, fecal pellets were collected from individually caged mice.

### 2.12. Statistical Analysis

The non-parametric Kruskal-Wallis test with Dunn's Multiple Comparison post test were used to compare the levels of antigen-specific IgG1, IgG2a, and IgA antibodies in immunized mice. A one-way ANOVA with a Bonferroni's post test

was used to compare the logarithms of CFU in feces from mice immunized using the different treatments previously described (section 2.9), and then challenged with EHEC O157:H7 strain. All the statistical analyses were performed using software Prism 5 (GraphPad).

### 3. Results

#### 3.1. Stable Transgenic Plants

Out of 100 explants, only 53 explants developed healthy plantlets in kanamycin selection media, of which 28 expressed IntC protein that was detected using ELISA and Western blot. Of these 28 plants, pNR49-derived lines 49-3, 49-4b, and pNR50-derived line 50-7 were selected as elite lines because of their levels of IntC expression. Elite lines were transferred from selective media into soil and grown in a green house. Tomato fruits were then collected and freeze dried as previously described.

The screening of putative transgenic plants was performed by intimin-specific ELISA of leaf extracts. Tomato plants transformed with pNR49 expressed higher levels of IntC (1.78% IntC per TSP) than those transformed with plasmid pNR50 (0.03% IntC per TSP) (Fig 2).

#### 3.2. IntC expression in freeze-dried tomato fruits

The expression levels of IntC in freeze-dried tomato fruits were tested using intimin-specific ELISA. In selected tomato plants from two different first and second generation lines, IntC expression in red fruits was better than in the green

fruits. In the first generation line 49-3, the expression of IntC was 0.52 and 0.40 mg per gram of freeze-dried red and green fruit, respectively. In line 49-4b, the expression of IntC was 0.54 and 0.42 mg per gram of freeze-dried red and green tomato fruit, respectively (Fig. 3a). The second generation plants (named 49-3.6 and 49-4b.3) expressed 1.28 and 0.72 mg of IntC per gram of freeze-dried red and green tomato fruit, respectively. In line 49-4b.3, IntC expression was 1.86 and 1.55 mg per gram of freeze-dried red and green tomato fruit, respectively (Fig. 3b). Hence, red freeze-dried tomatoes were used in subsequent studies and for the animal trials. Western blot showed a strong band of 33kDa corresponding to IntC protein was observed (Figs. 4a and 4b).

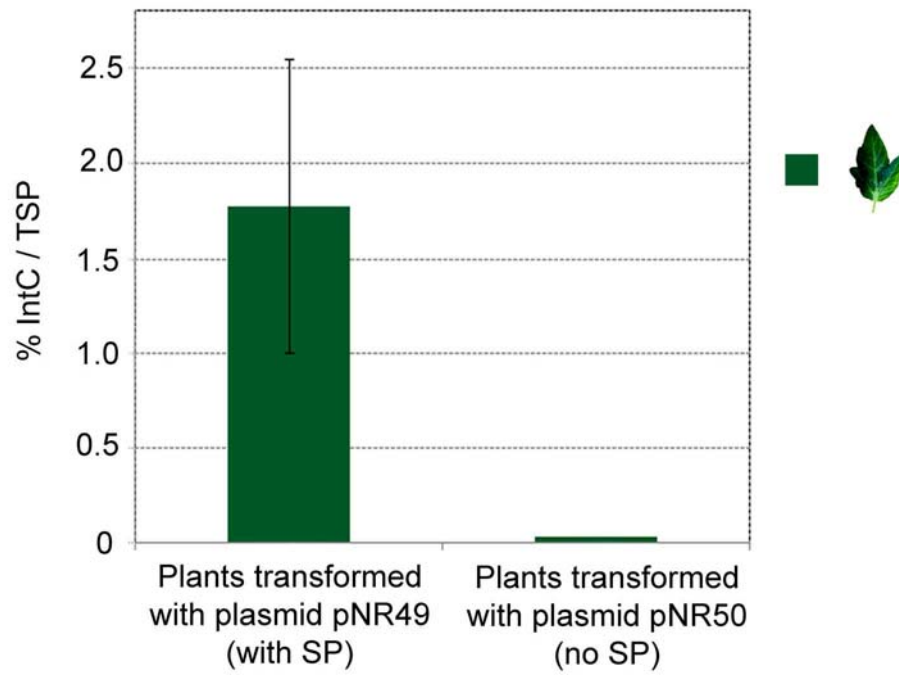

Figure 2. Expression of IntC in the first generation of tomato leaves. Tomato plants transformed with plasmid pNR49 expressed higher levels of IntC, 1.78% IntC per TSP, than those transformed with plasmid pNR50, 0.03% IntC per TSP.



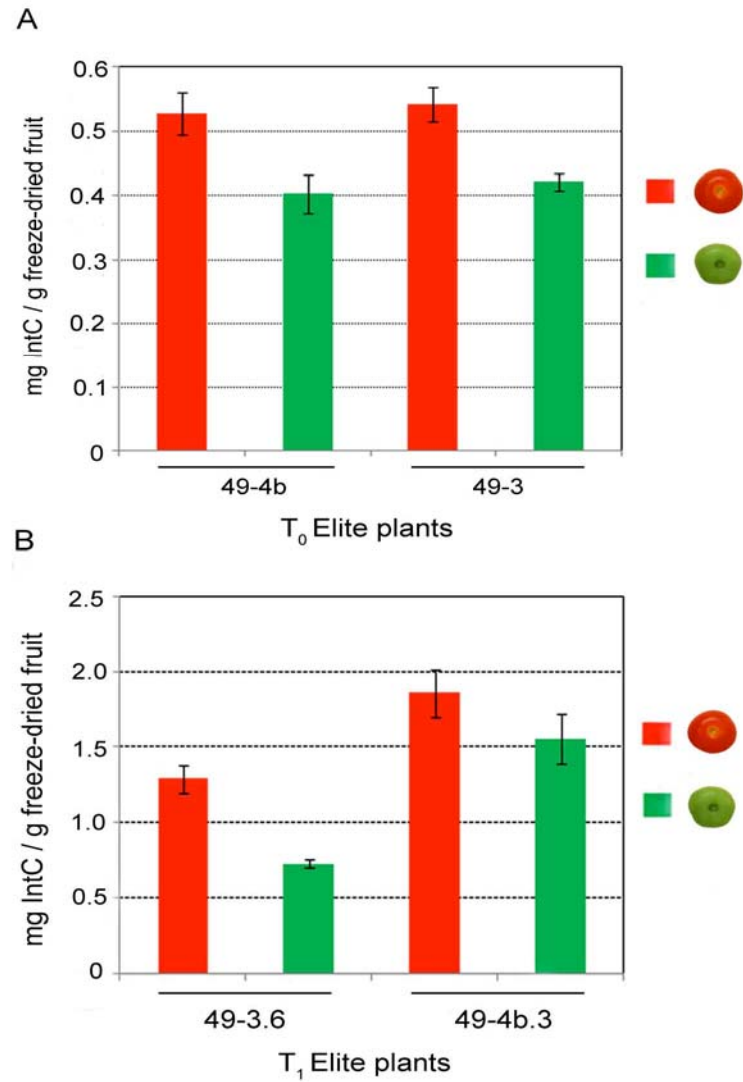

Figure. 3. IntC expression in the freeze dried tomato fruits from (A) T<sub>0</sub> (primary transformant) elite plants and (B) T<sub>1</sub> (second generation) elite plants. Plant names start with number 49 or 50 (indicating plants transformed with pNR49 or pNR50), followed by the line number.

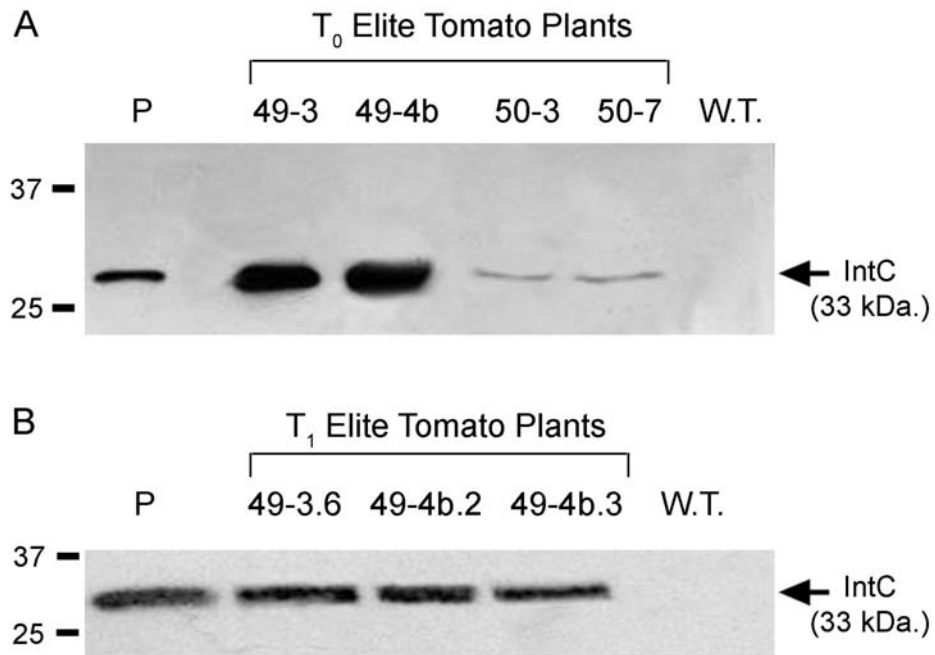

Figure 4. Expression of IntC in freeze-dried tomato fruits in T<sub>0</sub> and T<sub>1</sub> elite lines. All samples were standardized to contain 5 $\mu$ g TSP. P: positive control, 100ng of bacterial purified protein. W.T: wild type.

3.3. IntC purification from freeze-dried fruits and glycosylation analysis of IntC

Filtered supernatants of crude fruit extracts were purified using a Ni-Sepharose High Performance HisTrap-HP Column (GE Healthcare, Piscataway, NJ), according to the manufacturer's instructions. The expected 33kDa IntC band was observed both in Western blot and Coomassie-stained SDS-PAGE gel (Fig. 5a and 5b).

Glycosylation of the purified IntC was not indicated, because treatment with trifluoromethanesulfonic acid (TFMS), PNGase F, PNGase A or Endo H did not alter the mobility of the protein (Fig 6a and 6b).

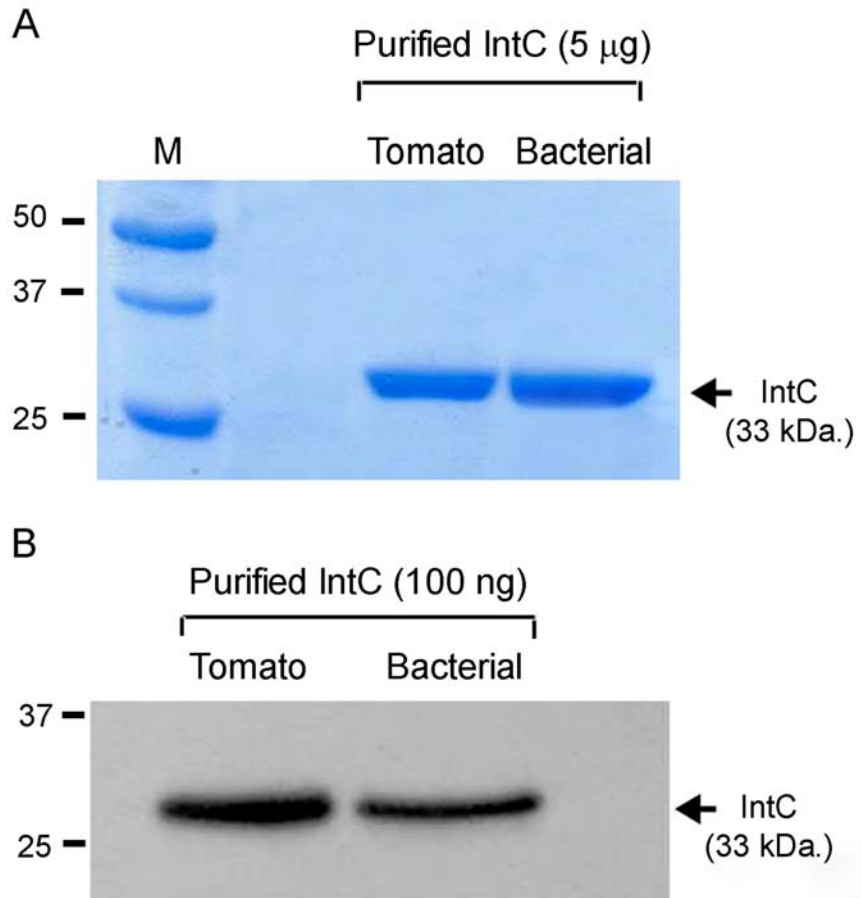

Figure 5. Purification of IntC from tomato fruits and bacteria. (A) Coomassie-stained gel, with 5 $\mu$ g antigens each lane. (B) Western blot probed with intimin-specific antibody, with 100ng antigens. M: Molecular weight marker.

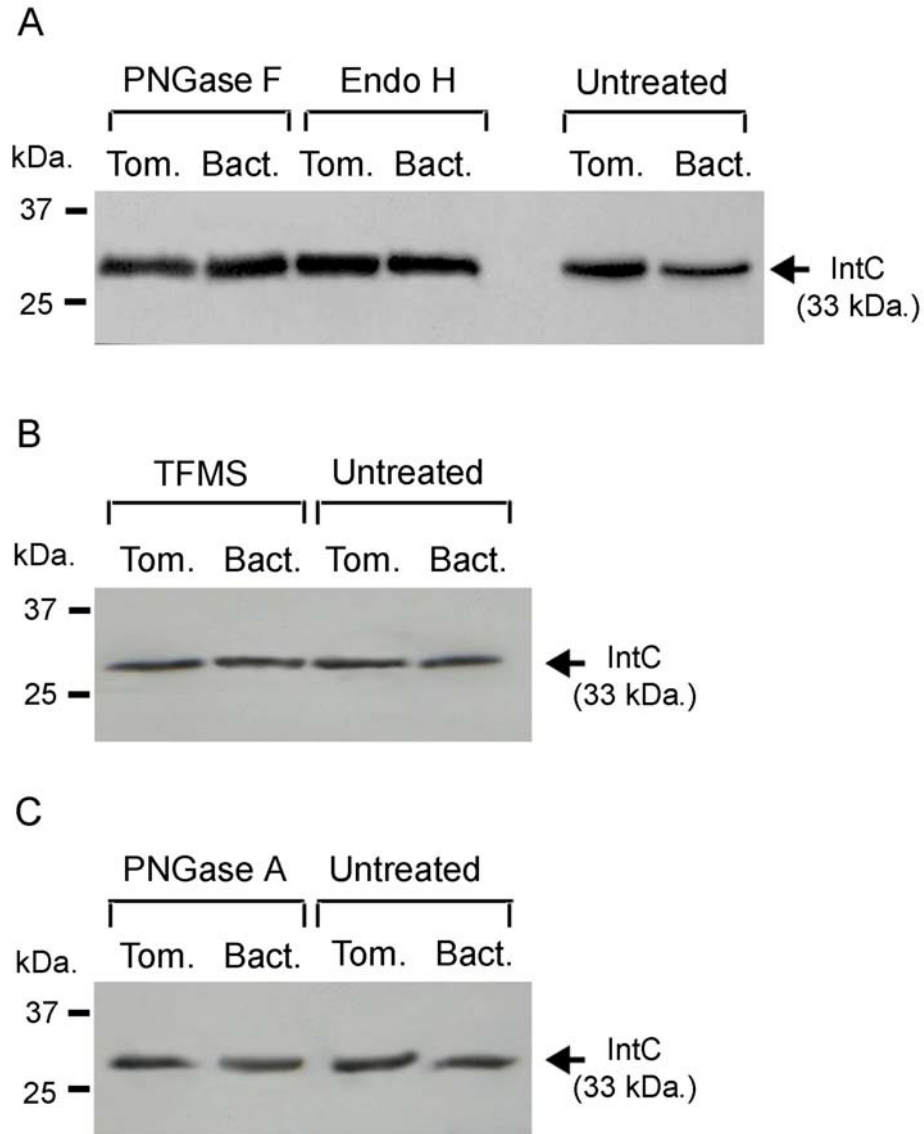

Figure 6. Deglycosylation of the purified IntC. Purified IntC from tomato and bacteria were treated with (A) PNGaseF or Endo H, (B) TMSF, or (C) PNGaseA, before loading 100ng on SDS-PAGE, blotting and probing with anti-intimin antibody. Untreated: same mass of antigens loaded without deglycosylation treatment.

### 3.4. Immunogenicity of tomato-derived IntC

After immunization with purified IntC from tomato (Table 1), BALB/c mice produced intimin-specific IgG1 and IgG2a antibodies in sera. In general, mice in all of the immunization groups produced higher levels of intimin-specific IgG1 than IgG2a antibodies (Fig 7a and 7b). Serum IgG1 levels raised in mice immunized IN with tomato-derived IntC and mice in the positive control group are both significantly different ( $P < 0.001$ ) than mice in the negative control group. Intimin-specific serum IgG2a titers in both of the immunized groups were significantly different than mice in the negative control group ( $P < 0.001$ ). Ratio for serum IgG1 to Serum IgG2a were also shown in table 2. Intimin-specific IgA titers were also detected in fecal samples from mice immunized IN with tomato-derived IntC, but not in mice in the positive control or mice in the negative control group (Fig. 8a and 8b). Intimin specific fecal IgA in mice immunized with tomato-derived IntC was significantly different than the mice in the negative control group and the group immunized with bacterial intimin ( $P < 0.01$  and  $P < 0.001$  respectively). The mice immunized IN with tomato-derived IntC produced intimin-specific vaginal IgA, but neither mice in the positive or negative control groups raised intimin-specific vaginal IgA. (Fig. 8a and 8b).

### 3.5. Bacterial challenge of immunized mice

After mice were challenged with *E. coli* O157:H7, the shedding of streptomycin-resistant *E. coli* O157:H7 strain 86-24 was evaluated for 11 days. Mice in the control group shed the bacteria during the entire 11 days of the evaluation period.

Table 1. Mice immunization groups and treatments: Mice in testing group (group I), mice in positive control group (group II) and mice in negative control (group III) were primed with 0.5µg bacterial-derived purified intimin intraperitoneally (I.P., with TiterMax as an adjuvant) and mice in group IV primed with PBS I.P. (TiterMax used as an adjuvant). Mice in testing group were boosted with tomato-derived purified intimin intranasally and mice in positive group boosted with bacterial-derived purified intimin intraperitoneally.

Groups	Prime	1 <sup>st</sup> Boost	2 <sup>nd</sup> Boost	3 <sup>rd</sup> Boost
Group I (Testing group)	0.5 µg B. Intimin I.P. (with TiterMax)	4 µg T. Intimin I.N. (with 10 µg CT)	4 µg T. Intimin I.N. (with 10 µg CT)	30 µg T. Intimin I.N. (with 10 µg CT)
Group II (Positive control)	0.5 µg B. Intimin I.P. (with TiterMax)	0.5 µg B. Intimin I.P. (with TiterMax)	0.5 µg B. Intimin I.P. (with TiterMax)	
Group III (Negative control)	0.5 µg B. Intimin I.P. (with TiterMax)			
Group IV (Negative control)	PBS I.P. (with TiterMax)			

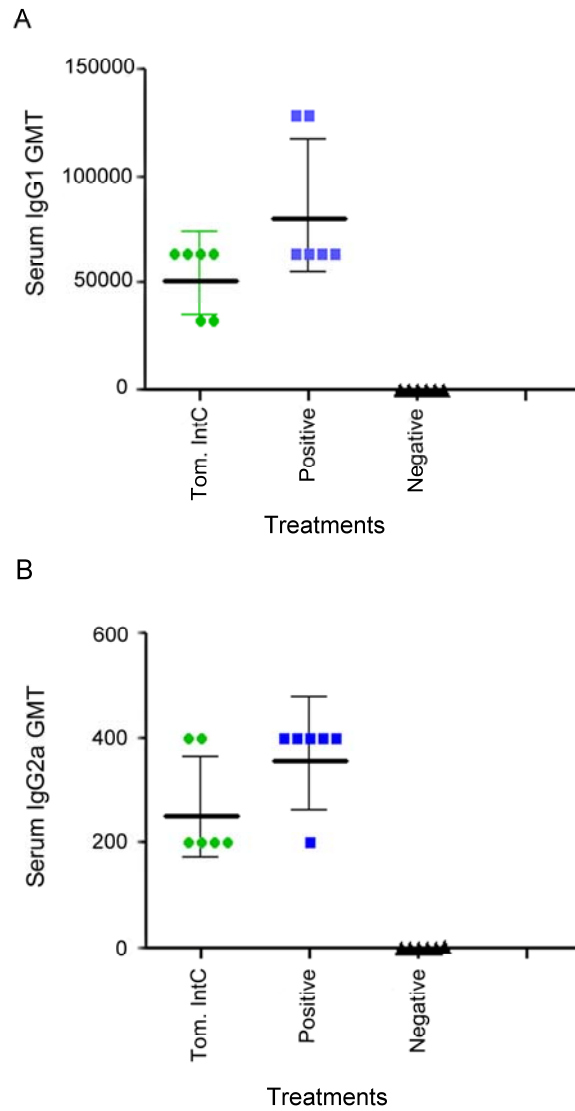

Figure 7. Antigen-specific IgG1 (A) and IgG2a (B) elicited in mice immunized IN with tomato-derived IntC (Tom. IntC), immunized IP with bacterial IntC only (Positive), or sham-immunized with PBS (Negative).



Table 2. IgG1 to IgG2a ratios for the mice immunized with tomato-derived intimin and mice in positive control.

<b>Mouse #</b>	<b>IgG1/IgG2a</b>	
	<b>INT</b>	<b>Positive</b>
1	320	160
2	320	320
3	320	160
4	80	320
5	160	320
6	160	160
<b>GMT</b>	201.587368	226.27417

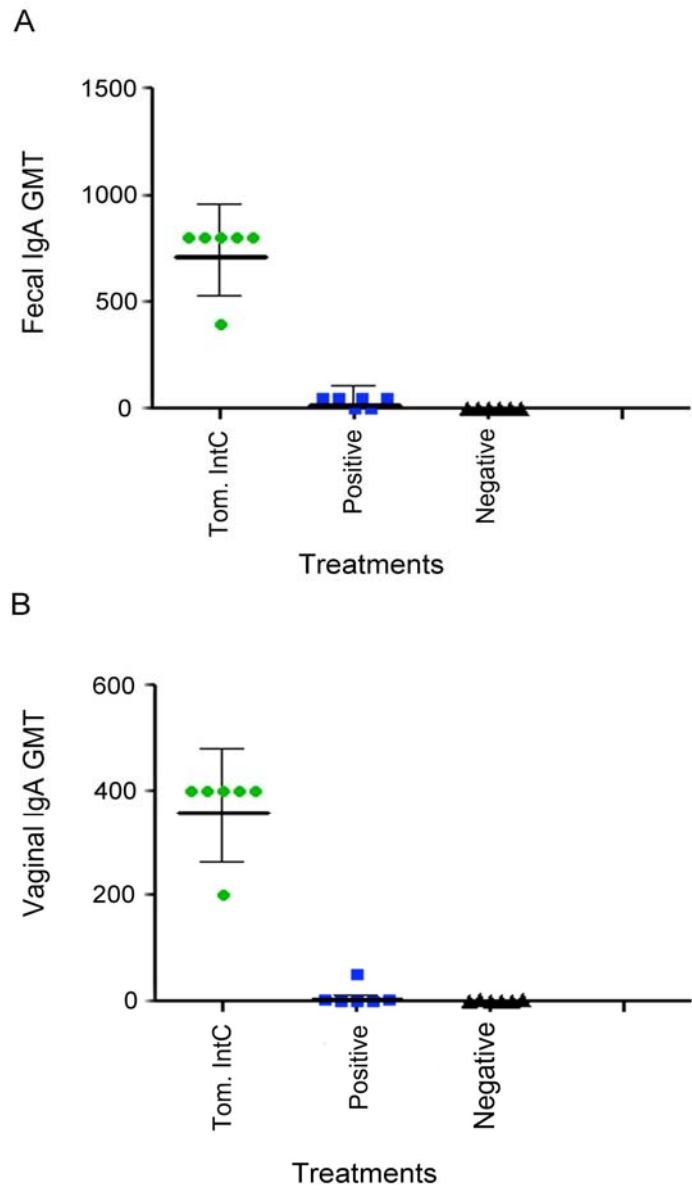

Figure 8. Antigen-specific fecal (A) and vaginal (B) IgA raised in mice immunized IN with tomato-derived IntC (Tom. IntC), immunized IP with bacterial IntC only (Positive), or sham-immunized with PBS (Negative).

However, mice immunized IN with tomato-derived IntC and mice in the positive control group cleared the bacteria from their systems in nine and eight days, respectively (Fig 9). In addition, there was a significant reduction in bacterial shedding starting at day 5 through 8 after the challenge in mice immunized IN with tomato-derived IntC compared to mice in the positive control group ( $P < 0.001$ ) (Fig. 9). We did not observe any weight change or abnormal behavior in mice after the challenge (data not shown).

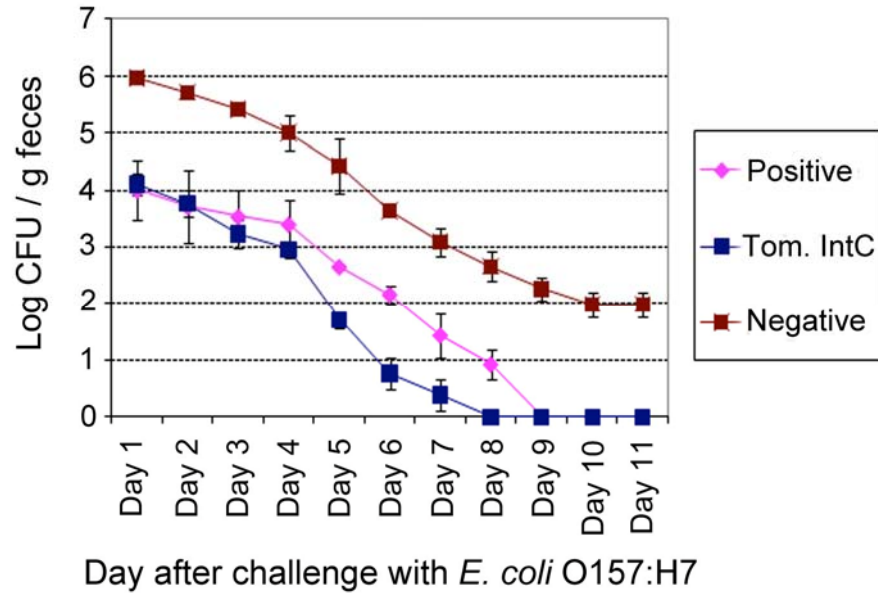

Figure 9. Shedding of bacteria after challenge of mice with *E. coli* O157:H7 strain 86-24 Str<sup>f</sup>. Mice were immunized IN with tomato-derived IntC (Tom. IntC), immunized IP with bacterial IntC only (Positive), or sham-immunized with PBS (Negative).

#### 4. Discussion

There have been previous attempts from different research groups to produce a vaccine to protect humans or animals from *E. coli* O157:H7 infection. One of the approaches used intimin as a vaccine candidate to prevent intestinal colonization in humans or animals by *E. coli* O157:H7 (Dean-Nystrom, Gansheroff et al. 2002).

In this study, we used an intimin subunit vaccine produced in tomato plants as a strategy to prevent intestinal colonization of *E. coli* O157:H7. Tomato is a good candidate for the production of plant-derived vaccines because it yields large masses of fruits and has well-established methods for industrial greenhouse culture and fruit processing (Alvarez, Pinyerd et al. 2006). Unfortunately, most of the proteins expressed in plants have a short shelf life if they are used fresh, as with tomato fruits (Rigano and Walmsley 2005). This problem can easily be solved by freeze drying the transgenic tomato fruits (Alvarez and Cardineau 2010). Hence, we chose to freeze-dry tomato fruits expressing IntC. We did not observe any degradation of IntC protein in freeze-dried tomato powder saved for a year in vacuum-sealed bags or 50 ml tubes at room temperature (data not shown). Thus, freeze-drying is an inexpensive and well-established technology that can be used to preserve IntC tomato fruits without recombinant protein degradation. Leaves from the first generation (T0) of putative transgenic tomato plants were tested by ELISA to confirm intimin expression. Tomato plants transformed with pNR49 expressed higher levels of IntC (1.78% TSP) than those plants transformed with pNR50 (0.03% TSP). Unlike pNR50, pNR49 has a VspA signal

peptide that directs the recombinant protein to be co-translationally translocated into the endoplasmic reticulum (ER), which resulted in higher IntC accumulation. Thus, we decided to continue our experiments only with tomato plants transformed with pNR49. Judge et al. (Judge, Mason et al. 2004) reported similar findings in IntC NT-1 transgenic cell lines transformed using the same plasmid constructs. Unfortunately, these authors found that the pNR49 cell lines producing the highest levels of IntC, after several months in culture, showed bands of higher molecular weight than that expected for IntC, suggesting glycosylation. In addition, antibodies raised against the higher molecular mass IntC recognized that IntC species, but not the bacterially-derived IntC. For this reason, Judge et al. (2004) speculated that the plant cell-directed glycosylation of IntC affected the antibody recognition of the bacterially-derived intimin, and used the non-glycosylated IntC derived from NT-1 cells transformed with pNR50 for mouse immunogenicity studies. We evaluated the tomato-derived IntC for potential glycosylation before the mouse studies, in order to avoid misinterpretation of the data. In contrast to the Judge et al. (2004) findings, our data indicate that the tomato-derived IntC was not glycosylated, because (a) it co-migrated on SDS-PAGE at the same molecular mass as bacterial IntC, which is not glycosylated, and (b) various chemical and enzymatic deglycosylation treatments had no effect on its mobility (Fig. 5).

In the mouse immunogenicity studies, we found that the tomato-derived IntC candidate vaccine was immunogenic, and elicited not only intimin-specific serum IgG1 and IgG2a responses (Fig. 6), but also induced mucosal immune responses

demonstrated by the presence of intimin-specific IgA in vaginal lavages and fecal pellets (Fig. 8a and 8b). In addition, mice immunized IN with tomato-derived IntC and challenged with *E. coli* O157:H7 shed the bacteria for a shorter period of time than mice both in the positive and negative control groups, which suggests a reduced time of *E. coli* O157:H7 intestinal colonization in mice (Fig. 9).

Taken together, the results presented here demonstrate the high potential of a mucosally-delivered tomato-derived IntC as a candidate vaccine for prevention of *E. coli* O157:H7 intestinal attachment and colonization. This is the first step towards the development of a vaccine for cattle that will reduce their infection by *E. coli* O157:H7, and thus limit the incidence of human infections as well.

## Chapter 3

### SHIGATOXIN B SUBUNIT-INTIMIN FUSION VACCINE TO PREVENT ESCHERICHIA COLI O157:H7 INFECTION

#### Abstract

*E. coli* O157:H7 is the most common cause of hemolytic uremic syndrome. Cattle represent the main reservoir for these bacteria. The *E. coli* O157:H7 outer membrane protein intimin is required for persistent colonization by this organism in numerous animal models that include neonatal and young calves. Thus intimin is a potential O157: H7 vaccine candidate for both humans and cattle. In this study we asked whether a fusion protein comprised of the C-terminal 1/3 of intimin from *E. coli* O157:H7 (IntC) and the Shiga toxin type 1 B subunit (StxB1) would enhance mucosal targeting and immunogenicity of intimin. We constructed and expressed the fusion protein StxB1-IntC, in which N-terminally His-tagged StxB1, a short linker (G<sub>4</sub>S)<sub>2</sub> and IntC were fused in-frame. This fusion protein as well as individually His-tagged protein StxB1 and IntC was purified by metal affinity chromatography and then 0.5µg of each protein was used to prime groups of BALB/c mice by IP injection Mice were then boosted intranasally with 30µg of IntC, StxB1, or StxB1-IntC. Mice immunized with StxB1-IntC produced the highest levels of specific serum IgG1 and IgG2a and fecal and vaginal IgA antibody against IntC or StxB1 than those immunized with IntC or StxB1 alone. After a challenge with *E. coli* O157:H7, mice immunized with StxB1-IntC cleared the inoculated bacteria from their intestine 4 days after the challenge, versus 7 or 10 days for bacterial clearance in mice immunized with StxB1 or IntC alone,



respectively. These results suggest an immunologically synergistic effect of the fusion protein, possibly mediated by mucosal targeting via StxB1 and/or IntC.

## 1. Introduction

In the United States, hemolytic uremic syndrome (HUS) associated with infection by enterohemorrhagic *Escherichia coli* (EHEC) serotype O157:H7 is the most common cause of acute kidney failure in children (Paton and Paton 1998).

Disease caused by EHEC is particularly dangerous for young children and the elderly population (Reiss, Kunz et al. 2006). In the United States, 73,480 cases of *E. coli* O157:H7 disease and additional ~36,740 cases of illness due to other serotypes of Shiga toxin-producing *E. coli* (STEC) are projected to occur each year (Mead, Slutsker et al. 1999). The impact of these infections (i.e. hospitalization, lost work days, etc) is predicted to cost as much as 3.3 billion dollars annually (Frenzen, Drake et al. 2005). Shiga toxins types 1 (Stx1) or type 2 (Stx2) are major virulence factors of *E. coli* O157:H7. The prototypic Stx is composed of one enzymatically active (N-glycosidase) A subunit (StxA, 32 kDa) and five B subunits (StxB, 7.7 kDa) (Furutani, Ito et al. 1990). StxA binds non-covalently to five identical B subunits. The pentameric StxB is responsible for binding to its receptor, a glybotriaosylceramide (Gb3), which facilitates entry of the enzymatically (N-glycosidase activity) active StxA into host cells, where the A<sub>1</sub> fragment of this subunit inhibits protein synthesis (Jacewicz, Clausen et al. 1986; Donohue-Rolfe, Jacewicz et al. 1989).

The EHEC genome contains a pathogenicity island called “locus of enterocyte effacement” (LEE) (Agin, Cantey et al. 1996). The LEE region contains five different operons named LEE1 to LEE5. The LEE 1, LEE2 and LEE3 operons encode the elements of a type III secretion system. LEE4 operon encodes some of the secreted proteins. LEE5 encodes the outer membrane protein intimin and its receptor named “translocated intimin receptor” (Tir). LEE is responsible for attachment and effacement (A/E) lesion formation. The intestinal lesion caused by EHEC is characterized by loss of microvilli and cytoskeletal rearrangement. The first step for the lesion formation is intimate attachment of the bacteria to the host. Intimin and Tir together play an important role in this intimate attachment. Hence, intimin has previously been used as a vaccine candidate for prevention of EHEC infections (McKee and O'Brien 1996; Stakenborg, Vandekerchove et al. 2006; van Diemen, Dziva et al. 2007)

In this study, we linked StxB1 (from Stx type 1) to the C-terminal third of intimin (IntC) to create a fusion protein (StxB1-IntC), which generated better mucosal and systemic immune responses in mice, as well as higher protection against infection with *E. coli* O157:H7 than either StxB1 or IntC delivered alone. We thus provide proof of principle that an StxB1 fusion protein is effective to develop an anti *E. coli* O157:H7 colonization vaccine candidate. Finally, we propose that StxB1 may be useful as a mucosal targeting molecule and/or adjuvant for the development of other mucosal vaccine candidates.

## 2. Materials and Methods

### 2.1. Plasmids

StxB1, which is identical to the StxB subunit from *Shigella dysenteriae* type 1 (Strockbine, Jackson et al. 1988), is the binding subunit of an A1:B5 oligomer of Stx1. The native bacterial sequence of StxB1 (Genbank M19437; (Strockbine, Jackson et al. 1988) was analyzed and a plant-optimized gene was designed that eliminated mRNA instability sequences and substituted plant-preferred codons where needed. The synthetic gene was prepared by assembly PCR using overlapping oligonucleotides spanning the entire sequence, and it was verified it by DNA sequencing. The plant-optimized StxB gene was inserted into our standard plant expression vector pIBT210 (Haq, Mason et al. 1995) at NcoI 5' and SacI 3' to make pStxB210 (made for expression in plants).

To make p6HStxB210, PCR using pStxB210 as template and primers N6HK (5'-GACCATGGGAGGATCTCACCATCACCATCATCACGGTACCCCAGATTG TGTGAC ), which incorporated a 6His tag, and VSPHT (5'-TGAATAGTGCATATCAGCATACTTA) produced a product that was digested with NcoI and BseRI. The previously constructed pIC-StxB1-D1, which contains an in-frame fusion of the plant-optimized StxB1 gene, a (G<sub>4</sub>S)<sub>2</sub> linker, and IntC (H. Mason, unpublished) was digested with BseRI and SacI. Finally pET26b (Novagen), which carries the pelB N-terminal signal peptide coding sequence, was digested with NcoI and SacI, and all three digested fragments ligated together to form pET26-StxBintC. To construct pET26-StxB, we used PCR with pET26-StxBintC as a template and primers T7 (5'-

AATACGACTCACTATAGG) and StxB1-Sac (5-GTTGAGCTCTTACCTAAAGATCACCTCAGAGAA). The PCR product and pET26b were digested with NcoI and Sac I and ligated to make pET26-StxB1. To make pET26-IntC, the IntC coding sequence was obtained from pNR50 (Judge, Mason et al. 2004) by digestion with NcoI and SacI, and ligated with pET26b that had been digested likewise. All plasmid constructs were sequenced to confirm the inserts.

## 2.2. Bacterial expression and purification of StxB1, IntC and StxB1-IntC

The plasmids pET26-IntC, pET26-StxB1, and pET26-StxB1IntC were mobilized into *E. coli* BL21 (DE3) by electroporation, and were confirmed in clones by plasmid preparation and restriction digestion. The bacteria were grown overnight at 37°C in Petri dishes containing solid medium Luria-Bertani (solid LB: 10 g/l bacto-tryptone, 5 g/l bacto-yeast, 10 g/l NaCl, 8 g/l agar, pH 7.0) supplemented with 50 mg/l kanamycin (LB-kan) as the selective agent. One bacterial colony was selected and grown overnight in 5 ml liquid LB-kan. The 5 ml bacterial culture used to inoculate 500 ml LB-kan. When the large bacterial culture reached 0.6-0.8 optical density at 600 nm (OD<sub>600</sub>), 1mM isopropyl β-D-1-thiogalactopyranoside (IPTG) was added to the culture, which was grown for 5 h at 30°C with shaking. Cells were harvested by centrifugation at 5000xg for 30 minutes (Avanti J-E, Beckman Coulter, Brea, CA), the supernatant removed and the cell pellet washed with 1X phosphate buffered saline (PBS, 137 mM NaCl, 2.7 mM KCl, 10 mM sodium phosphate dibasic, 2 mM potassium phosphate monobasic, pH of 7.4), the pellet was weighed and saved overnight at -80°C. The

bacterial pellet was resuspended in 10 ml binding buffer (20mM sodium phosphate, 20mM imidazole, and 500mM sodium chloride) per gram of pellet. Bacterial cells were lysed by sonication (550 Sonic Dismembrator, Fisher Scientific, Pittsburg, PA) on ice until the cloudy solution became clear. The bacterial lysate was centrifuged for 30 min at 10,000xg and His-tagged protein was purified using a Ni Sepharose high performance HisTrap-HP column (GE Healthcare, Piscataway, NJ), according to the manufacturer's instructions. Fractions eluted with 500mM imidazole were collected and dialyzed against PBS using slide-a-lyzer dialyzing cassettes (Pierce, Rockford, IL).

### 2.3. SDS-PAGE and Western Blot

The total soluble protein (TSP) content of each HisTrap-HP elution fraction was determined by BCA assay (Pierce, Rockford, IL), using BSA as the reference standard. For denaturing conditions, equal amounts of TSP were mixed with 6x SDS gel loading buffer (300mM Tris-HCl, pH 6.8, 600mM dithiothreitol, 12% SDS, 0.6% bromophenol blue, 60% glycerol). Samples were boiled for 15 min, placed on ice, and centrifuged 5 s before loading them on a pre-cast 4-20% Tris-HCl sodium dodecyl sulfate polyacrylamide gel (SDS-PAGE) (BioRad, Hercules, CA). For non-denaturing conditions; proteins were not boiled or no DDT was added. Proteins were separated by electrophoresis at 35mA for 2 h using Tris-glycine running buffer (25mM Tris, 250mM glycine and 0.1% SDS) and a Bio-Rad Mini-Protein apparatus (Bio-Rad, Hercules, CA). SDS-PAGE gels were stained with Coomassie dye (Fermentas, Glen Burnie, MD) or proteins were

transferred onto a polyvinylidene fluoride (PVDF) membrane at 80 volts for 2 h (Bio-Rad, Hercules, CA). The PVDF membrane was blocked overnight at 4°C in 5% dry milk in PBST (PBS buffer plus 0.1% Tween 20), and the next day the blocking continued for 2 h on a shaker at room temperature. The PVDF membrane was washed six times in PBST for 15 minutes each, and then incubated 1 hour at 37°C with rabbit polyclonal antibodies against Shiga toxin 1 (Wen, Teel et al. 2006b) or intimin protein diluted in 1% dry milk in PBST at 1:5000 and 1:8000, respectively. The membrane was washed in PBST with agitation four times, 15 minutes each. The membrane was incubated with horseradish peroxidase-conjugated goat anti-rabbit IgG (Sigma-Aldrich, Saint Louis, MO) at 1:10,000 dilution in 1% dry milk in PBST. ECL Plus kit (Amersham Biosciences, Piscataway, NJ) was used to detect bands specific for StxB (7.7 kDa), IntC (33 kDa), or StxB-IntC fusion protein (40.7 kDa) as per the manufacturer's instructions. Bacteria-derived purified IntC (expressed via pET26-IntC and purified in our laboratory) and StxB (BEI Resources, <http://www.beiresources.org/>) were used as positive controls. StxB1 and StxB1-intC purified samples were analyzed by Western blot in denaturing (1%SDS and 250mM DDT and boiled) and non-denaturing (no DTT added and not boiled) conditions. Pre-cast 4-20% Tris-HCl SDS-PAGE gels (BioRad, Hercules, CA) were used for western blot analysis.

#### 2.4. Receptor binding of StxB1 and StxB1-IntC: Gb3 binding assay

Globotriaosylceramide (Gb3) binding assay was modified based on Ashkenazi and Cleary (Ashkenazi and Cleary 1989). Gb3 (Matreya LLC, Pleasant Gap, PA) was dissolved in Chloroform/methanol (2:1) and 1 µg Gb3 per well was added to high binding polystyrene EIA/RIA 96-well microplates (Corning, Glendale, AZ). Plates were incubated at 23°C until all the fluid in the wells evaporated. Plates were washed with PBST three times and blocked with 5%BSA in PBST for 1 hour at 37°C. After washing the plates three times with PBST, different amounts (25, 50, 100 and 150ng) of purified StxB1, StxB1-IntC, or IntC, proteins were diluted in 1% BSA/PBST and added to the plates. Plates were incubated for 1 hour at 37°C, and washed three times with PBST, and incubated 1 hour at 37°C with rabbit polyclonal antibodies against StxB1 diluted in 1% dry milk in PBST at 1:1000. After three washes with PBST plates were incubated with HRP-conjugated goat anti-rabbit IgG (Sigma-Aldrich, Saint Louis, MO) at 1:10,000 dilution in 1% dry milk in PBST. TMB peroxidase substrate (Bio-Rad, Hercules, CA) was used for detection, and the reaction was stopped with 1N H<sub>2</sub>SO<sub>4</sub>. The absorbance was read at 450 nm in an ELISA plate reader (MRX-tc, Dynex technologies, Chantilly, VA).

#### 2.5 Mouse Immunization and Challenge

Twenty-four-week-old female BALB/c mice were separated into four different groups of seven animals each, and vaccinated with the StxB1, IntC and StxB1-IntC proteins previously expressed and purified from *E. coli*. On day zero mice

were primed intraperitoneally (IP) with 0.5 $\mu$ g purified IntC, StxB1 , StxB1-IntC fusion protein or PBS. TiterMax Gold (Sigma-Aldrich, St. Louis, MO) was used as adjuvant according to the manufacturer's instructions. On days 21, 28, and 42 the mice were boosted intranasally (IN) with 30 $\mu$ g of either IntC, StxB1, or StxB1-IntC supplemented with 10 $\mu$ g of cholera toxin (CT, Sigma-Aldrich, Saint Louis, MO) as adjuvant.

Blood samples were collected from the submandibular vein and incubated at room temperature for 10 minutes to let the blood coagulate. Samples were then centrifuged at 3000xg for 10 minutes, sera transferred to clean tubes, and saved at -20°C. Fecal pellets and vaginal lavages were collected from individually housed mice and saved at -20°C. Proteins were extracted from fecal pellets using 1ml extraction buffer (10  $\mu$ g/ml leupeptin, 0.1% Tween 20 in PBS) per 100 mg of fecal pellets. Samples were kept at 4°C for 20 minutes before a 1 min homogenization using a bullet blender homogenizer (Next Advance Inc., Averill Park, NY). Homogenized samples were centrifuged at 20,800xg in an Eppendorf Microcentrifuge 5417R (Eppendorf, Hauppauge, NY) for 10 minutes at 4°C. Cleared supernatant was collected and analyzed by ELISA immediately, or saved at -20°C for future tests. Vaginal lavages were thoroughly homogenized using a vortex, and samples were centrifuged in an Eppendorf Microcentrifuge 5417R at 17900xg for 10 minutes at 4°C.

For challenge studies, mice were challenged 14 days after the last boost.

Previously immunized female BALB/c mice were fasted overnight and water was removed from the cages 4 hours prior to the bacterial administration.



Streptomycin resistant EHEC O157:H7 strain 86-24 Str<sup>r</sup> (Melton-Celsa, Rogers et al. 1998) were plated one night before on LB supplemented with streptomycin, and 2-3 colonies were selected from a fresh plate to prepare liquid culture. Bacteria were cultured in 25ml of LB culture containing 100µg/ml streptomycin and incubated on shaker at 37°C for 3 hours. The culture was centrifuged at 3000xg and resuspended in freshly prepared, filter-sterilized 2.5 ml of 20% sucrose. Two doses were administered four hours apart and in each dose mice were fed (Mohawk, Melton-Celsa et al. 2010) 10<sup>8</sup>-10<sup>9</sup> colony forming units (CFU) of bacteria. Following the challenge, fecal pellets were collected from individually caged mice to determine bacterial shedding. Fecal pellets were collected from individually caged mice and were diluted 1:10 by weight into PBS buffer. Then they are homogenized and centrifuged as described previously for ELISA and plated into sorbitol MacConkey agar supplemented with streptomycin.

#### 2.6. ELISA to determine IgG1 and IgG2a titers in mouse serum, and IgA titers in feces and vaginal lavages

High binding polystyrene EIA/RIA 96-well microplate (Corning, Glendale, AZ) were coated with 50ng of either IntC or StxB1 proteins expressed in *E. coli* as described above. In order to compare antibody titers specific for StxB1 or IntC, plates were coated with StxB1 or IntC proteins, respectively, and incubated at room temperature for 4 h and then overnight at 4°C. Plates were washed with PBST (PBS pH 7.4 with 0.05% Tween 20) and blocked with 5% skim milk in PBST (5% PBST) for 1 h at 37°C. After another three washes with PBST, the

sera were two-fold serially diluted in the ELISA plate and incubated for 1 h at 37°C. After the plates were washed three times with PBST, they were incubated with goat anti-mouse IgG1-HRP (Southern Biotech, Birmingham, Alabama) at dilution 1:2,500 in 1% skim milk in PBST (1% PBST) for IgG1 detection, or goat anti-mouse IgG2a-HRP (Southern Biotech, Birmingham, Alabama) at dilution 1:2,500 in 1% skim milk in PBST for IgG2a detection. For IgA detection either in fecal pellets or in vaginal washes, goat anti-mouse IgA-HRP (Sigma-Aldrich, St Louis, Mo) was used at dilution 1:1,000 in 1% skim milk in PBST. Plates were washed 3 times with PBST and finally, detection was done using TMB peroxidase substrate (Bio-Rad, Hercules, CA). The reaction was stopped with 1N H<sub>2</sub>SO<sub>4</sub> and absorbance read at 450 nm in an ELISA plate reader (MRX-tc, Dynex technologies, Chantilly, VA). Titers were calculated as the highest dilution factor of the serum that produced an absorbance reading of 0.1 at 450 nm after subtracting non-specific absorbance reading from non-treated mice.

## 2.7. Statistical analysis

The non-parametric Kruskal-Wallis test with Dunn's Multiple Comparison post test was used to compare the levels of specific IgG1, IgG2a and IgA antibodies raised against StxB1 or IntC in immunized mice. A one-way ANOVA with a Bonferroni's post test was used to compare the logarithms of CFU in feces from mice immunized with StxB1, IntC, or StxB1-IntC and then challenged with EHEC O157:H7. All statistical analyses were performed using software Prism 5 (GraphPad).

### 3. Results

#### 3.1. *E. coli* protein expression and purification

The pET26b expression vectors used in this study are represented in Figure 1. Bacterial lysates from *E. coli* expressing StxB, IntC, or StxB-IntC were purified by metal affinity using HisTrap-HP columns. The purified proteins were separated by SDS-PAGE and stained with Coomassie blue or analyzed by Western blot. The expected specific protein bands of 33kDa for IntC (Fig. 2A and B), ~7.7 kDa for StxB1 (Fig. 3A and 3B), or 41kDa for StxB-IntC (Fig 4A and 4B), were observed in both Western blot and Coomassie blue stained SDS-PAGE gels. Based on examination of Coomassie and silver-stained gels, we estimate that the recombinant proteins were ~80% pure.

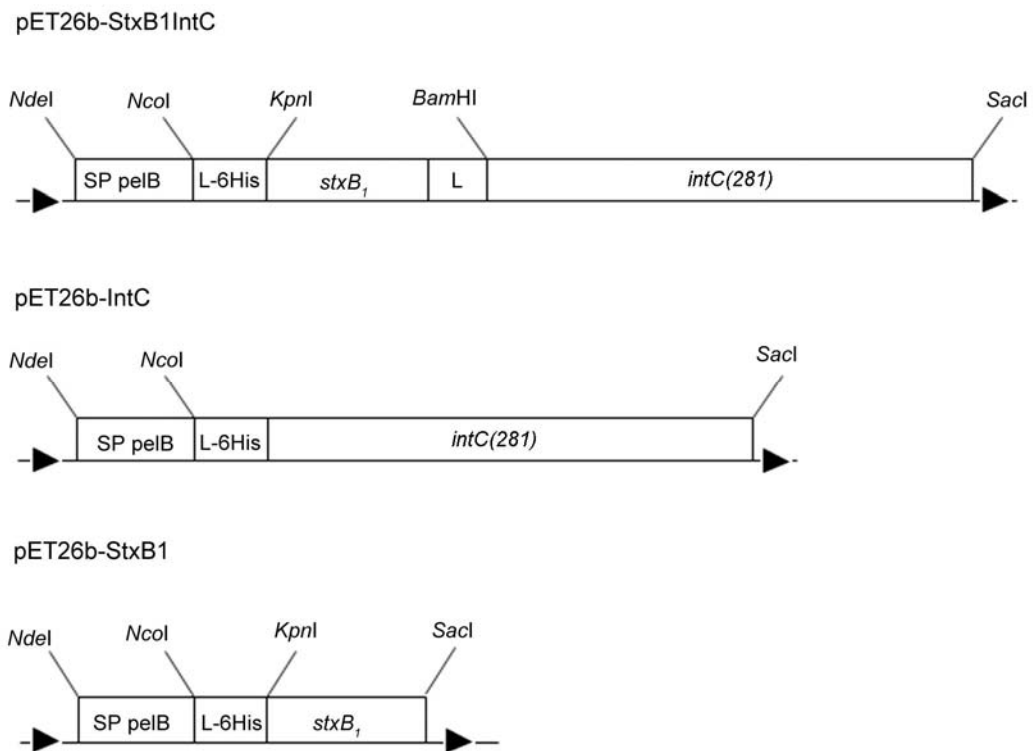

Figure. 1: Plasmid constructs pET26-StxB1IntC, pET26-StxB1, and pET26-IntC used for recombinant protein expression in *E. coli*. Antigen genes were cloned in pET26b, which provides periplasmic targeting by use of the pelB signal peptide. L, (G<sub>4</sub>S)<sub>2</sub> linker; pelB SP, pelB signal peptide; 6His, tag of 6 histidines for metal affinity purification.

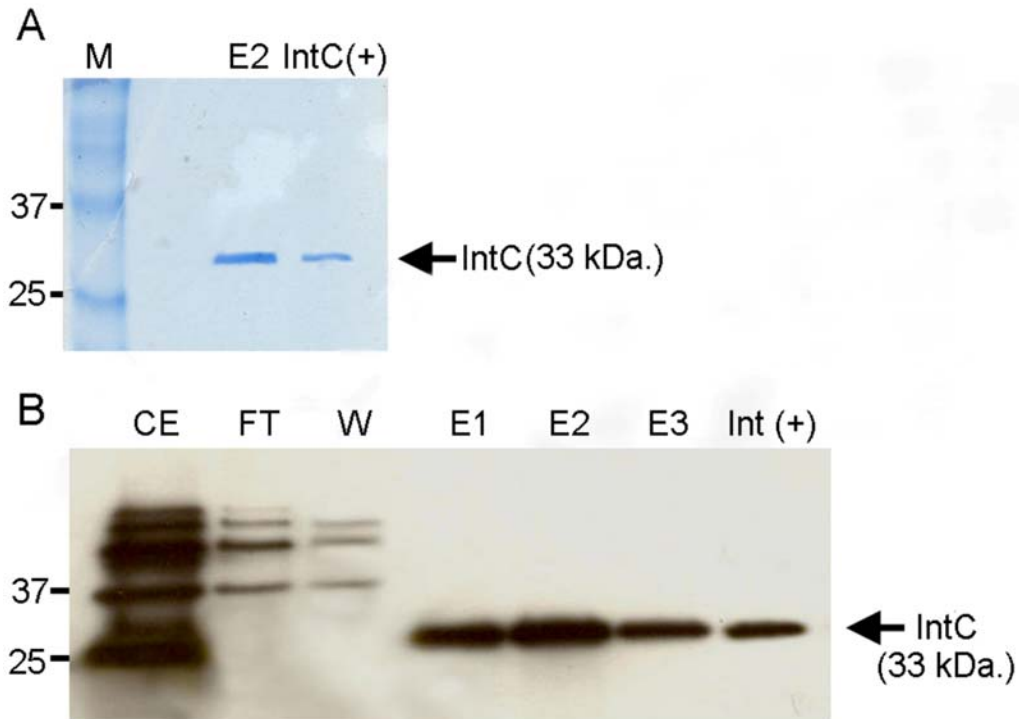

Figure 2. Expression of IntC. His-tagged IntC were expressed in *E. coli*, purified by metal affinity, and separated by SDS-PAGE. Gels were stained with Coomassie blue (A) or transferred to a PVDF membrane and probed with anti-intimin antibodies (B). E1-E3: elution fractions from the metal affinity column; M, protein molecular marker (protein sizes are in kDa.); CE, crude cell extract; FT, unbound column flow-through; IntC (+), reference standard proteins.

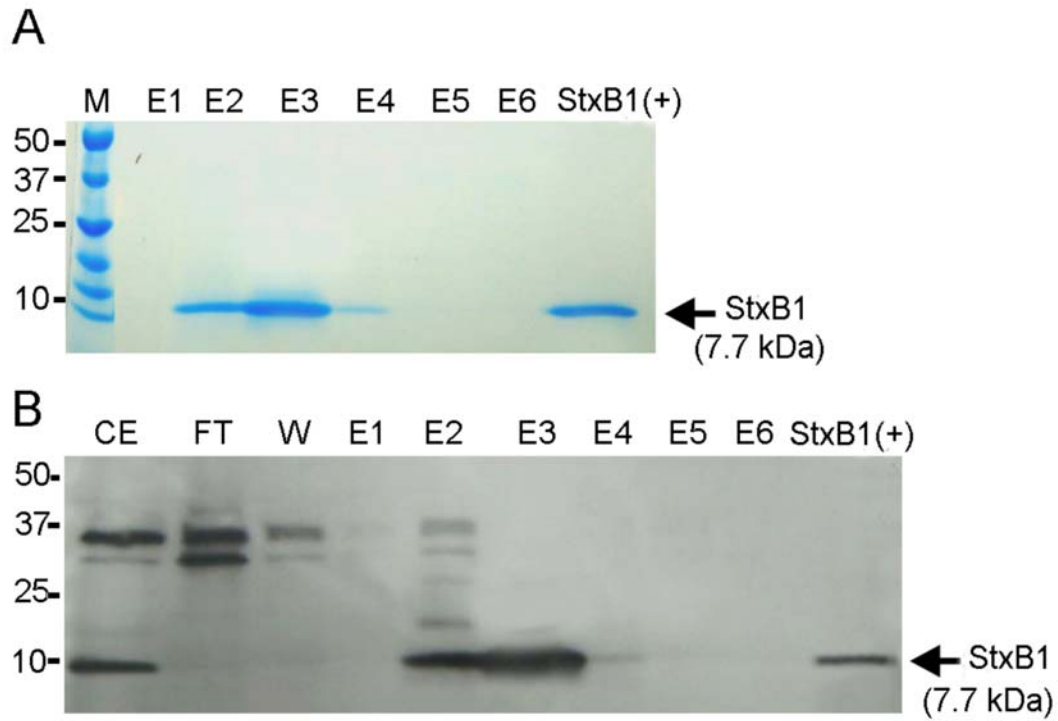

Figure 3. Expression of StxB1. His-tagged StxB1 were expressed in *E. coli*, purified by metal affinity, and separated by SDS-PAGE. Gels were stained with Coomassie blue (A) or transferred to a PVDF membrane and probed with anti-StxB1 antibodies (B). E1-E6: elution fractions from the metal affinity column; M, protein molecular marker (protein sizes are in kDa.); CE, crude cell extract; FT, unbound column flow-through; StxB1 (+), reference standard protein.

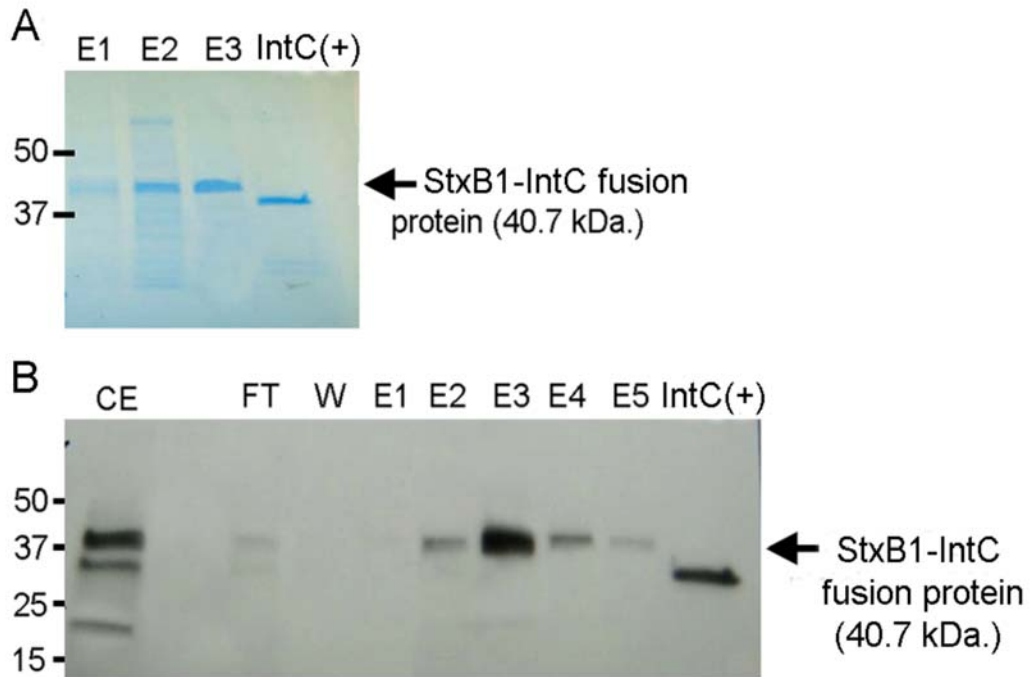

Figure 4. Expression of StxB1-IntC. His-tagged StxB1-IntC was expressed in *E. coli*, purified by metal affinity, and separated by SDS-PAGE. Gels were stained with Coomassie blue (A) or transferred to a PVDF membrane and probed with anti-intimin antibodies (B, D and F). E1-E5: elution fractions from the metal affinity column; M, protein molecular marker (protein sizes are in kDa.); CE, crude cell extract; FT, unbound column flow-through; IntC(+), reference standard protein.

### 3.2. Oligomer formation and Gb3 receptor binding of StxB1 and StxB1-IntC

Evidence of pentamer formation upon expression of StxB1 and StxB1-IntC was observed on Western blots (Fig 5A). Under denaturing conditions, the expected monomer sizes of 7.7kDa and 40.7 kDa were observed corresponding to StxB1 and StxB-IntC respectively (Fig. 5A). With non-denaturing conditions, higher molecular weight bands were observed, which suggest pentameric assembly of the B subunits. Monomer size bands were also observed for both StxB1 and StxB1-IntC under non-denaturing conditions, and the relative intensities suggest that the efficiency of assembly was ~90% for StxB1 and ~75% for StxB1-IntC. Binding activity of pentameric StxB1 and StxB1-IntC to Gb3 was measured by ELISA (Fig. 5B). StxB1 showed higher binding affinity than StxB1-IntC on a protein mass basis, but accounting for the 5-fold larger size of the fusion protein, it appears that StxB1-IntC bound Gb3 very well.



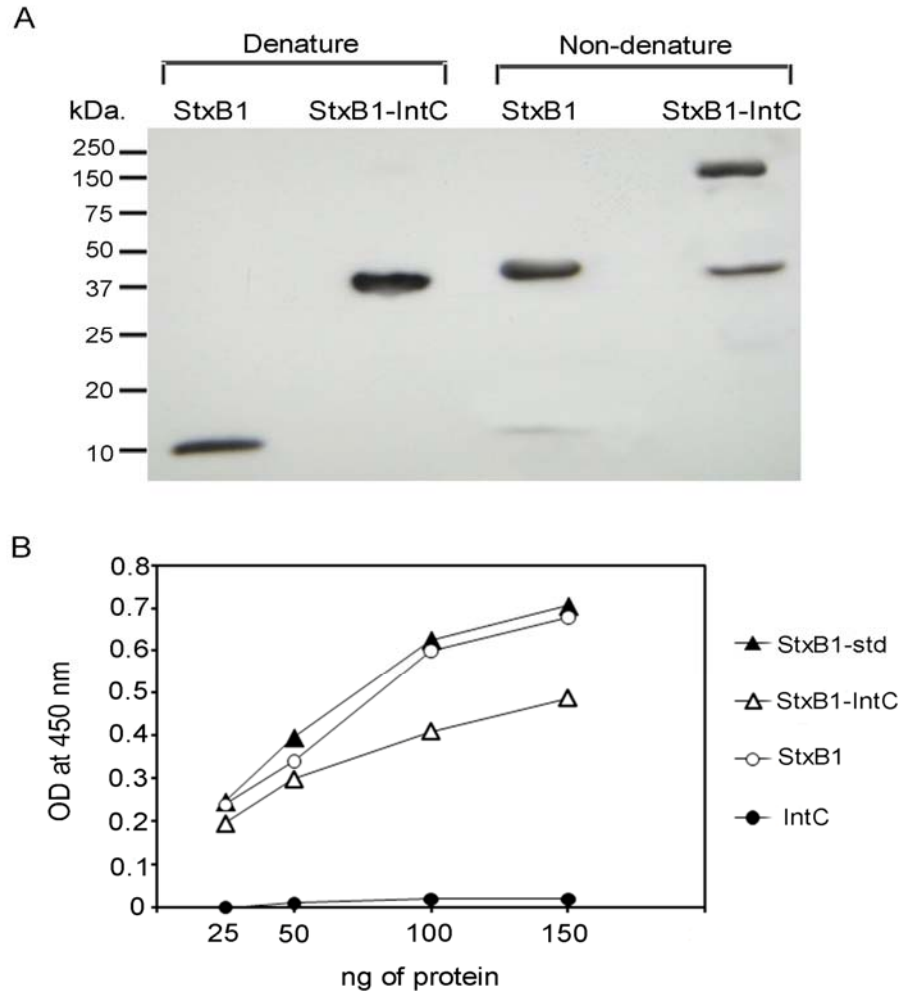

Figure 5. StxB1 and StxB1-IntC oligomer formation and binding to Gb3 receptor. (A) Western blot to detect denatured and non-denatured StxB1 and StxB1-IntC. Denature: samples were boiled in SDS sample buffer containing 100mM DTT. Non-denature: samples were not boiled and sample buffer did not contained DTT. In the non-denaturing condition, higher molecular weight protein bands were observed in both StxB1 and StxB1-IntC, indicating oligomer formation. (B) Gb3 ELISA showed binding of StxB1 and StxB1-IntC antigens to Gb3. StxB1-std, recombinant StxB1 (BEI Resources); IntC, negative control.

### 3.3. Mouse Immunization

Immunization of BALB/c mice (Table 1) with purified StxB1, IntC or StxB1-IntC provoked specific serum IgG1 and IgG2a antibodies against StxB1 and IntC proteins. In all the immunized animals, serum IgG1 titers were higher than serum IgG2a titers, which suggested a predominantly type 2 T-helper cell (Th2) response. of the Th2 response is associated particularly with humoral antibody responses. The StxB1-IntC fusion generated significantly higher ( $P < 0.01$ ) IgG1 and IgG2a titers than mice immunized with either StxB1 or IntC alone (Fig. 6 and Fig. 7). IgA titers were detected in fecal samples and vaginal lavages in all of the mice in groups 1, 2 and 3 (immunized animals), but not those in group 4 (negative control mice). Higher fecal and vaginal IgA titers were observed in mice that were immunized with the StxB1-IntC fusion than in those immunized with StxB1 or IntC alone (Fig. 8 and Fig. 9). IgA titers in vaginal lavages were higher (Fig 9) than in fecal samples (Fig 8), but the protease-rich gut environment probably caused underestimation of IgA in fecal samples.

Table 1. Mice immunization groups and treatments: Mice in group I were primed with IntC alone, mice in group II were primed with StxB1 alone, mice in group III were primed with StxB1-IntC fusion protein. Prime was performed intraperitoneally (I.P.) and TiterMax used as an adjuvant for all of the groups. Mice in were boosted intranasally with 30µg of same antigen that they were primed with.

Groups	Prime	1st Boost	2nd Boost	3rd Boost
Group I	0.5 µg B. IntC I.P. (with TiterMax)	30 µg T. IntC I.N. (with 10 µg CT)	4 µg T. Intimin I.N. (with 10 µg CT)	30 µg T. Intimin I.N. (with 10 µg CT)
Group II	0.5 µg B.StxB1 I.P. (with TiterMax)	30 µg B. StxB1 I.N. (with 10 µg CT)	30 µg B. StxB1 I.N. (with 10 µg CT)	30 µg B. StxB1 I.N. (with 10 µg CT)
Group III	0.5 µg B. StxB1-IntC I.P. (with TiterMax)	30 µg B. StxB1-IntC I.N. (with 10 µg CT)	30 µg B. StxB1-IntC I.N. (with 10 µg CT)	30 µg B. StxB1-IntC I.N. (with 10 µg CT)
Group IV	PBS I.P. (with TiterMax)			

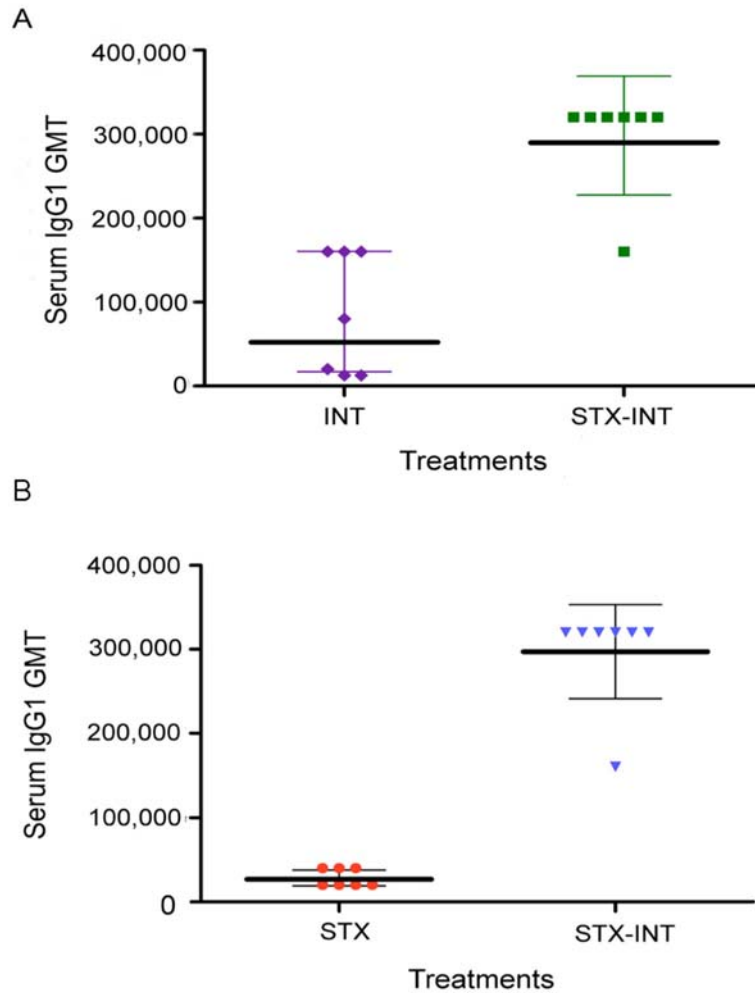

Figure 6. Serum IgG1 antibodies specific for intimin (A) or StxB1 (B) elicited in mice immunized with IntC, StxB1 or StxB1-IntC. Mice were primed IP with 0.5 $\mu$ g of the indicated antigen, followed by IN boosting with 30 $\mu$ g of the same antigens at days 21, 28, and 42. Sera were obtained 14 days after the last boost. Mice immunized with StxB1-IntC raised significantly higher ( $P < 0.01$ ) antigen-specific IgG1 antibody compared to mice immunized with IntC (A) or StxB1 (B). GMT, geometric mean titer (heavy bar)  $\pm$  95% CI (confidence interval). The 7 individual mouse endpoint titers are shown as data points.

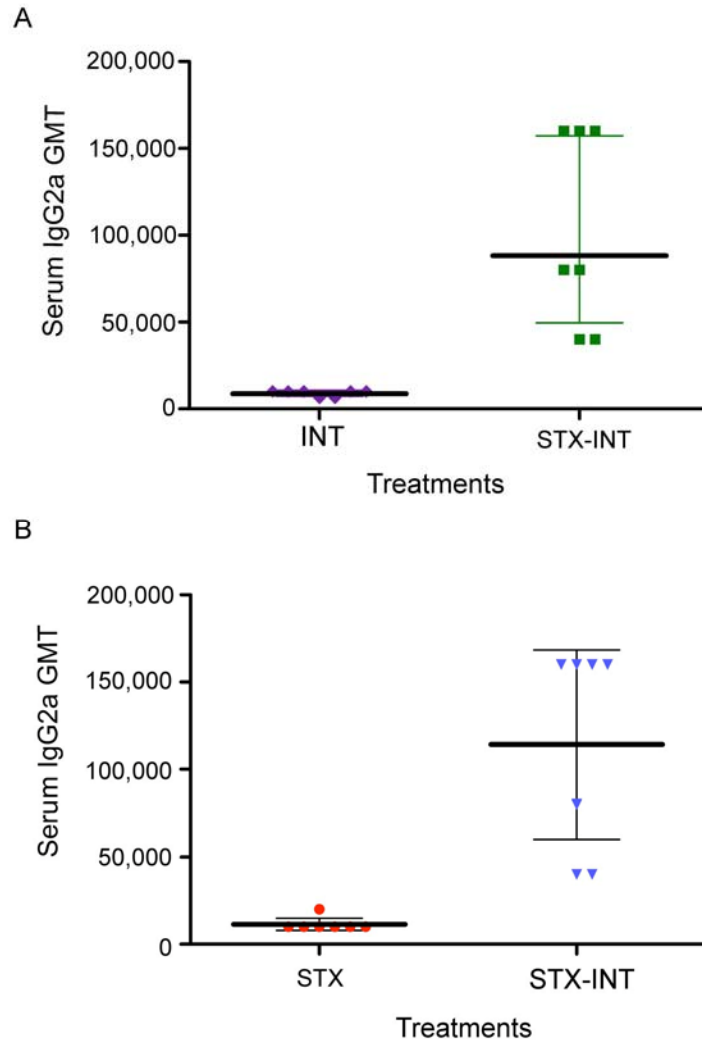

Figure 7. Serum IgG2a antibodies specific for intimin (A) or StxB1 (B) elicited in mice immunized with IntC, StxB1 or StxB1-IntC. Mice were primed IP with 0.5 $\mu$ g of the indicated antigen, followed by IN boosting with 30 $\mu$ g of the same antigens at days 21, 28, and 42. Sera were obtained 14 days after the last boost. StxB1-IntC immunized mice produced significantly higher ( $P < 0.01$ ) antigen-specific IgG2a antibodies compared to IntC (A) or StxB (B). GMT, geometric mean titer (heavy bar),  $\pm$  95% CI (confidence interval). The 7 individual mouse endpoint titers are shown as data points.

Table 2. IgG1 to IgG2a ratios in immunized mice

IgG1/IgG2a				
Mouse #	Int-C	StxB1-IntC	StxB1	StxB1-IntC
1	8	4	0.25	2
2	16	2	0.125	2
3	16	2	0.25	2
4	2	4	1	4
5	16	4	0.25	4
6	2	8	0.5	8
<b>GMT</b>	7.127189745	3.563594873	0.564980262	5.174802104

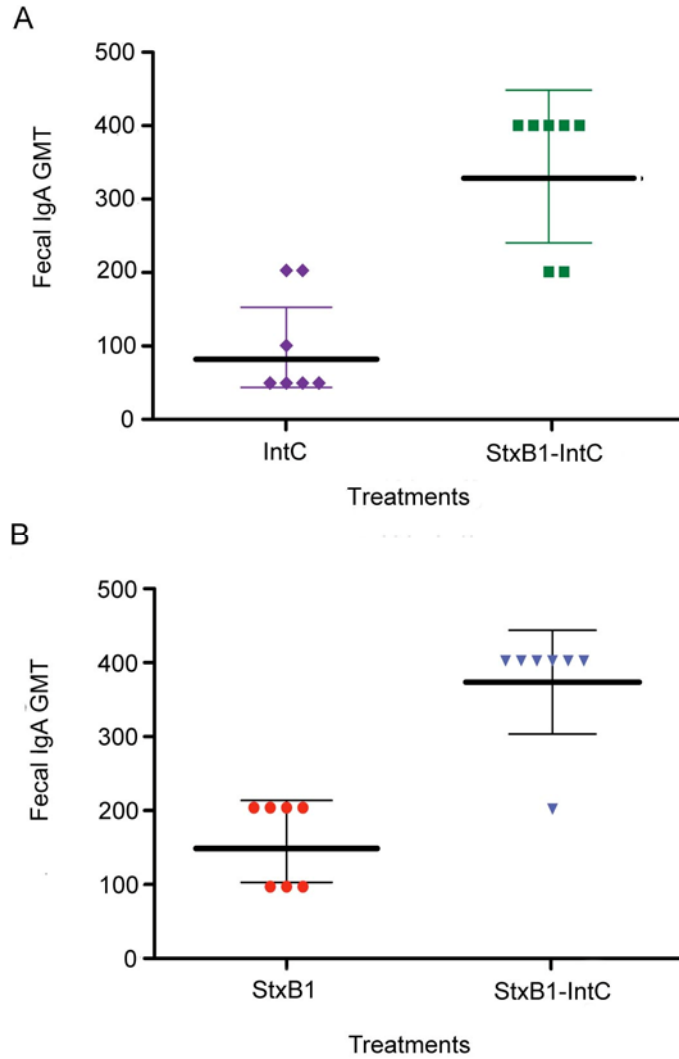

Figure 8. Fecal IgA specific for intimin (A) or StxB1 (B) in mice immunized with IntC, StxB1, or StxB1-IntC. StxB1-IntC immunized mice produced significantly higher ( $P < 0.01$ ) antigen-specific fecal IgA antibody compared to IntC (A) or StxB1 (B). GMT, geometric mean titer (heavy bar)  $\pm$  95% CI (confidence interval). The 7 individual mouse endpoint titers are shown as data points.

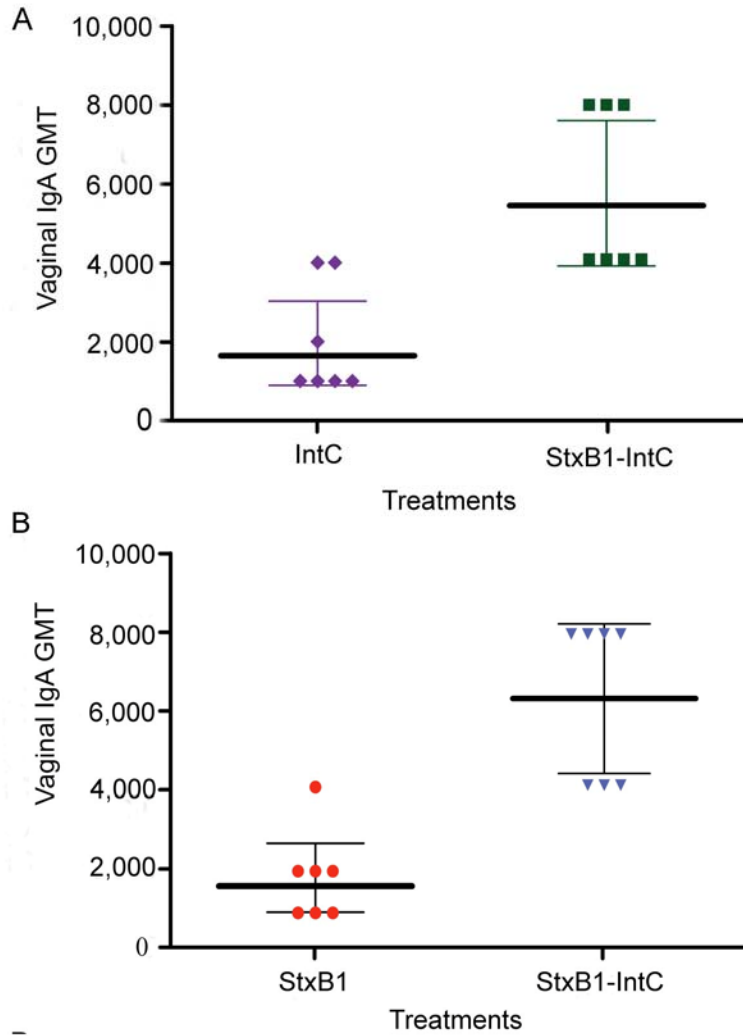

Figure 9. Vaginal IgA specific for intimin (A) or StxB1 (B) in mice immunized with IntC, StxB1, or StxB1-IntC. Mice immunized with StxB-IntC raised significantly higher ( $P < 0.01$ ) antigen-specific vaginal IgA antibody compared to mice immunized with IntC (A) or StxB1 (B). GMT, geometric mean titer (heavy bar) and 95% CI (confidence interval). The 7 individual mouse endpoint titers are shown as data points..



### 3.4. Challenge of Immunized Mice

In this study, shedding of streptomycin-resistant *E. coli* O157:H7 strain 86-24 was evaluated for 11 days after challenge (Fig. 10). Mice in the control group shed the bacteria for the full evaluation period (11 days). Mice immunized with StxB1 alone also shed the bacteria for 11 days, although at lower rates than the negative control mice for the first 5 days. Conversely, mice immunized with IntC or StxB1-IntC cleared the bacteria from their systems in six days and three days, respectively. Thus, we observed a benefit of immunization with the StxB1-IntC fusion protein over IntC alone. Mice immunized with StxB1-IntC cleared the bacteria significantly faster than those mice immunized with either IntC alone or StxB1 alone ( $P<0.001$ ). We did not observe any weight change or abnormal behavior in mice after the challenge (data not shown).

The time of bacterial shedding in mice immunized with StxB1-IntC fusion protein was significantly reduced compare to mice immunized with IntC ( $P<0.001$ ), StxB ( $P<0.001$ ), or no treated control ( $P<0.001$ ) group (3, 6, 11, and 11 days, respectively) (Fig. 10).

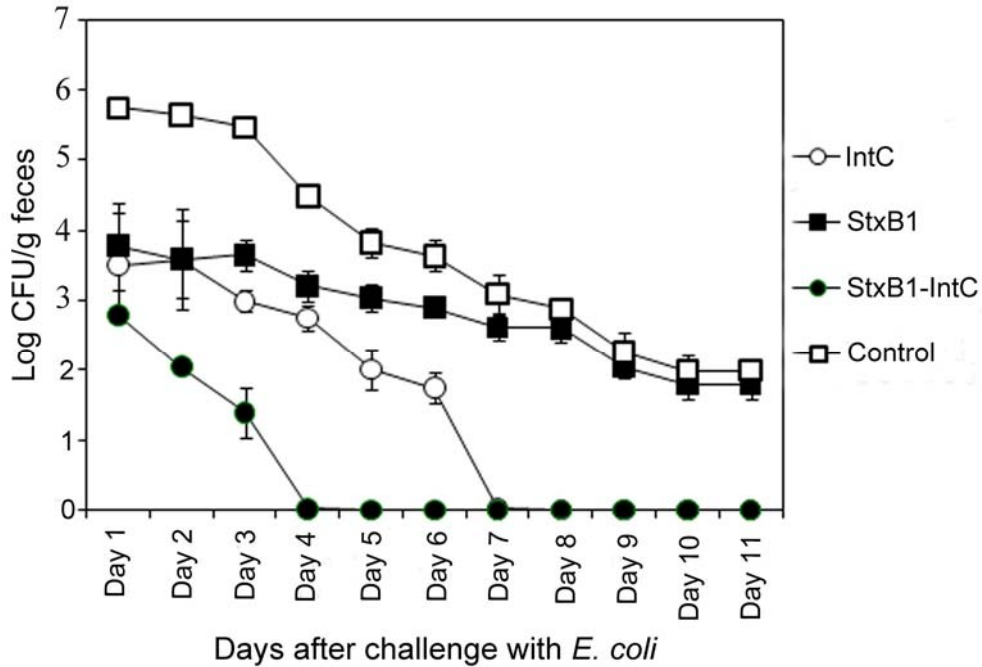

Figure 10. Bacterial shedding after challenge with *E. coli* O157:H7 strain 86-24 Str<sup>r</sup>. Mice immunized with StxB1, IntC or StxB1-IntC, or sham-immunized control mice were fed bacteria, and streptomycin resistant bacteria shed in feces were counted each day up to 11 days after challenge. The data points are means  $\pm$  SD of 3 replicate determinations. The length of bacterial shedding in mice immunized with StxB1-IntC fusion protein was significantly reduced compare to mice immunized with IntC ( $P < 0.001$ ), StxB ( $P < 0.001$ ), or no treated control ( $P < 0.001$ ) group (3, 6, 11, and 11 days, respectively)

#### 4. Discussion

HUS caused by EHEC infection is a medical emergency that results in 5-10% mortality. It is the most frequent cause of acute renal failure in children, although the majority of the infected people recover completely (Corrigan and Boineau 2001). The most common route of EHEC infection is food-borne, which explains up to 85% of the cases. Meat products cause most infections, but vegetables such as spinach can also be sources (Maki 2006; Grant, Wendelboe et al. 2008).

Despite the high incidence of severe EHEC infections, there is no available commercial vaccine to prevent this disease. Moreover, antibiotic therapy is not considered to be an effective method to treat the infection, since antibiotics might cause the release of more bacterial toxin, which increases the risk of HUS (Wong, Jelacic et al. 2000; Amirlak and Amirlak 2006; Iijima, Kamioka et al. 2008; Bavaro 2009).

Since Donnenbergi et al. (Donnenberg, Tzipori et al. 1993) reported the requirement of intimin for attachment of the *E. coli* O157:H7 to the host cell, intimin has been proposed as a vaccine candidate to prevent *E. coli* O157:H7 colonization. Gansheroff et al. (Gansheroff, Wachtel et al. 1999) demonstrated that the antibodies raised against intimin reduce colonization of *E. coli* O157:H7 in mice, rabbit and Hep-2 cells in vitro. Dean-Nystrom et al. (Dean-Nystrom, Gansheroff et al. 2002) showed that intimin administered to pregnant swine protects them from developing intestinal lesions, and furthermore, their colostrum protects the suckling piglets from colonization by *E. coli* O157:H7. Judge et al (Judge, Mason et al. 2004) tested a plant cell-based intimin vaccine in mice and

reported a significant decrease in the duration of colonization by *E. coli* O157:H7 in treated mice as compared to the control group (8.6 days versus 13.4 days, respectively). They primed mice IP with 15µg of plant-derived intimin and then boosted them orally (feeding) with 15µg of plant-derived intimin. Agin et al. (Agin, Zhu et al. 2005) used an intimin mutant *E. coli* strain to prevent colonization of *E. coli* O157:H7 in rabbits. The intimin-specific antibodies raised by these animals conferred protection against *E. coli* O157:H7 infections. Cataldi et al (Cataldi, Yevsa et al. 2008) reported a systemic and mucosal immunity in mice after intranasal immunization with 20µg of bacterially derived intimin. McNeilly et al (McNeilly, Mitchell et al., 2010) immunized cattle with a mixture of purified intimin, EspA (*E. coli* secreted protein A) and Tir, which reduced the shedding of *E. coli* O157:H7. Based on these reports that support the intimin protein as a vaccine candidate, we developed a transgenic tomato plants expressing IntC (Chapter 2). Unfortunately, many recombinant antigens are poorly immunogenic when they are administered only by the mucosal route (Cataldi, Yevsa et al. 2008). Moreover, our IntC delivered IN required a priming dose delivered parenterally in order to maximize its efficacy. Therefore, there is a great need for strategies to improve the mucosal immunogenicity of recombinant vaccines.

In the present study, we used a fusion of the mucosal targeting molecule StxB1 to IntC as a strategy to induce strong mucosal and systemic antibody responses, with the idea that StxB1-IntC could be a more effective vaccine candidate than IntC or StxB1 alone. We demonstrated that StxB1-IntC induced stronger mucosal and

systemic immune responses, and conferred a more effective protection in the mouse model than IntC or StxB1 alone.

Although StxB1 monomers contain Gb3 binding sites (Ling, Boodhoo et al. 1998), the pentameric structure of StxB1 is likely to provide cooperative binding effects that enhance the binding of Gb3. Therefore, we confirmed the formation of B subunit oligomers Western blotting with proteins resolved under non-denaturing conditions, and demonstrated efficient Gb3 binding of StxB1 and StxB1-IntC (Figs. 5A and 5B). Interestingly, the N-terminal 6-His tag on StxB1 did not interfere with pentamer assembly, as >90% of the purified StxB1 showed assembled oligomers upon non-denaturing Western blot. The His-tagged StxB1-IntC fusion protein assembled with less efficiency, but still the great majority of purified antigen displayed the oligomeric form. Moreover, the fusion protein bound Gb3 on a protein mass basis approximately equivalent to StxB1. Mice immunized with StxB-IntC produced higher titers of antigen-specific vaginal and intestinal IgA than those mice vaccinated with IntC or StxB alone. Vaginal antigen-specific IgA titers were approximately two times higher than the intestinal antigen-specific IgA titers. A possible explanation is that the route of antigen delivery plays an important role in generating site-specific antibodies (Holmgren and Czerkinsky 2005). In this study, even though the intranasal delivery of the antigen induced higher titers of vaginal IgA than intestinal IgA, the intestinal colonization time of the bacteria was reduced in mice vaccinated with IntC and StxB1-IntC compared to the control or StxB1 alone. Antigen-specific IgG1 titers were higher than the IgG2a titers in all the treatment groups,

suggesting a Th2 response, which is necessary to generate strong and protective IgA and IgG1 responses. We also found that mice immunized with StxB1-IntC generated a significantly higher ( $P < 0.01$ ) IgG1 and IgG2a responses than those vaccinated with IntC or StxB1 alone.

The time of bacterial shedding in mice immunized with StxB1-IntC fusion protein was significantly reduced compare to mice immunized with IntC ( $P < 0.001$ ), StxB ( $P < 0.001$ ), or no treated control ( $P < 0.001$ ) group (3, 6, 11, and 11 days, respectively) (Fig. 10). These results indicate that the StxB1-IntC fusion protein is a better candidate vaccine to limit *E. coli* O157:H7 intestinal colonization in mice than IntC alone.

Mice immunized with StxB1 alone had a significant difference from control mice from days one through seven. These findings support a potential cross-reactivity between Stx1 and Stx2, because the challenge strain that we used produces Stx2. Some researchers (Donohue-Rolfe, Acheson et al. 1989; Bielaszewska, Clarke et al. 1997; Ludwig, Karmali et al. 2002) observed immunological cross-reactivity between Stx1 and Stx2. However, Wen et al. (2006a) and Strockbine et al. (1988) reported no cross-neutralizing activity between Stx1 and Stx2. In our study, mice immunized with StxB1 showed significantly less bacterial shedding during days one through seven, but the difference disappears starting at day eight and thereafter shows the same pattern as unimmunized mice. Mohawk et al. (Mohawk, Melton-Celsa et al. 2010) showed that neutralizing antibodies against Stx2 reduce the colonization by Stx2 producing bacteria, and thus our observation

of a slight protective effect by immunizing with StxB1 is consistent with a slight cross-reactivity with StxB2.

However, we must also consider that StxB was shown to have an adjuvant activity. These workers (Ohmura-Hoshino, Yamamoto et al. 2004) found that StxB administered IN with ovalbumin induced the up-regulation of CD80, CD86, and CD40 on dendritic cells of the nasal associated lymphoid tissue, and produced stronger antibody responses than ovalbumin alone. Thus, they suggest that StxB could be used as a mucosal adjuvant for the induction of Th2-type, CD4<sup>+</sup> T cell mediated mucosal IgA and systemic IgG responses. Therefore, the presence of StxB1 in our fusion protein might be acting to enhance the presentation of IntC antigens by nasal dendritic cells, thus boosting antibody responses.

An alternative explanation is that the binding of StxB1 to its Gb3 receptor drove more efficient mucosal (IN) delivery of IntC and thus provoked stronger antibody responses in mice vaccinated with the StxB1-IntC fusion than in mice that received StxB or IntC alone. Another study (Haicheur, Benchetrit et al. 2003) showed enhanced IgG2a antibody responses in mice immunized with ovalbumin chemically coupled to StxB, as compared to ovalbumin alone. They found that that the StxB component induced antigen-specific CTL and humoral antibody responses with a Th1-type polarization. We also observed a higher anti-IntC IgG1/IgG2a ratio induced by immunization with the StxB1-IntC fusion as compared with IntC alone, but IgG1 was still dominant. Thus, we obtained a mixed Th1/Th2 type response to IntC, which could have been mediated by the StxB1 component. The higher antibody titers might facilitate a faster clearing of

the ingested bacteria from the gut. Another feasible explanation for enhanced immunogenicity of the fusion protein is the interaction of intimin with the nucleolin receptor (Sinclair and O'Brien 2004), although this binding is not as specific as StxB1 to its Gb3 receptor.

Based on our results with StxB1-IntC, it is likely that fusion proteins with StxB1 can be used for other vaccine candidates, especially those that could benefit from mucosal immune responses. Taken together, the results presented here demonstrate for the first time the potential of StxB1-IntC fusion protein as a multi-component vaccine candidate to limit *E. coli* O157 H7 infections, and show the potential of StxB1 as a mucosal targeting molecule when fused to IntC.



## Chapter 4

### ELECTRON MICROSCOPY

#### Abstract

*E. coli* O157:H7 protein, intimin, is an important vaccine candidate since it has been proven to reduce colonization of the host by these bacteria (Ghaem-Maghami, Simmons et al. 2001; Dean-Nystrom, Gansheroff et al. 2002; Judge, Mason et al. 2004; Agin, Zhu et al. 2005; Carvalho, Teel et al. 2005; Cataldi, Yevsa et al. 2008). As previously described, we expressed C terminal of intimin in tomato plants and we used two different constructs, pNR49 and pNR50 (see chapter 2). Selected transgenic lines were grown in the tissue culture first and they were transferred to the green house for maturation.

In this chapter we investigate the differences and similarities at the sub-cellular level between the plants that were transformed with pNR49 and plants transformed with pNR50.

#### 1. Introduction

In 1992 Mason et al (Mason, Lam et al. 1992) reported for the first time expression of hepatitis B surface antigen in transgenic tobacco plants. Ever since then, expression of different proteins to use as a vaccine candidate in plants has been an area of interest for over two decades (Thanavala, Huang et al. 2006).

Demand for recombinant biopharmaceutical has been growing recently and plants

are one of the popular approaches to fulfill this demand since plants are inexpensive for large scale production and free from human pathogens (Mett, Farrance et al. 2008; Tiwari, Verma et al. 2009).

We also have used tomato plants to express intimin as a vaccine candidate to prevent colonization of the host by *E. coli* O157:H7.

## 2. Materials and method

*Lycopersicon esculentum* variety Tanksley TA234 plants were grown in the green house. Green fruit excised from the elite lines and surface sterilized with 70% ethanol and they were thoroughly washed with sterile water. Green fruit pericarp samples cut into approximately 2X2 mm in the primary fixative, which contains 2% glutaraldehyde and 2% paraformaldehyde in 50mM sodium phosphate buffer. Samples were then fixed in the same fixative for 2 hours at 4°C. Plant samples were washed in 50mM sodium phosphate buffer for 30 minutes. All of the samples were then post fixed in 2% osmium tetroxide at 23°C for 2 hours. Tissue samples were washed in 50mM sodium phosphate buffer, followed by dehydration in graduated ethanol series (10, 20, 30, 40, 60, 80 and 100% ethanol) at room temperature. Lastly tissue samples were infiltrated with spur and molded at 60°C. Embedded tissue samples were cut into thin section by using Leica Ultracut R microtome and sections were observed on transmission electron microscope (Philips CM12S Scanning Transmission EM).

### 3. Results and Discussion

Physiologically, tomato fruit from the plants transformed with pNR50 were smaller than fruit from those that were transformed with pNR49. The plants transformed with pNR50 had less foliage compared to either plants transformed with pNR49 or the non-transformed tomato plants (wild type). Plants transformed with pNR49 had more intimin expression level (Chapter 2).

We observed cellular structure of the plants that were transformed either with pNR49 or pNR50 and wild type (non-transformant) by electron microscopy. We used leaves (Fig. 1) and the fruit of the line 49-4b.3 (Fig. 2), leaves (Fig.3) and fruit (Fig. 4) of 50-7.3 and used wild type tomato leaves (Fig. 5) and fruit (Fig6).

We observed endoplasmic reticulum (er) or rough endoplasmic reticulum (rer), chloroplast (ch), cell wall (cw), golgi (g) or trans golgi network (tng) mitochondria (m), nucleus (n), nuclear envelope (ne) and plasmodesmata (pd).

Among all of the samples we did not observe any difference in subcellular structured between the leaves and fruits that were transformed with either pNR49 or pNR50. Although we have observed some physical differences between two different transgenic lines (49-4b.3 and 50-7.3) we did not observe any differences in terms of cell structures and cell organelles.

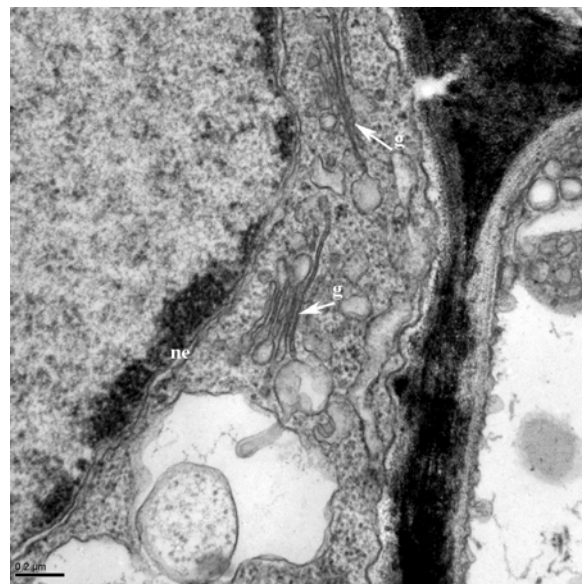
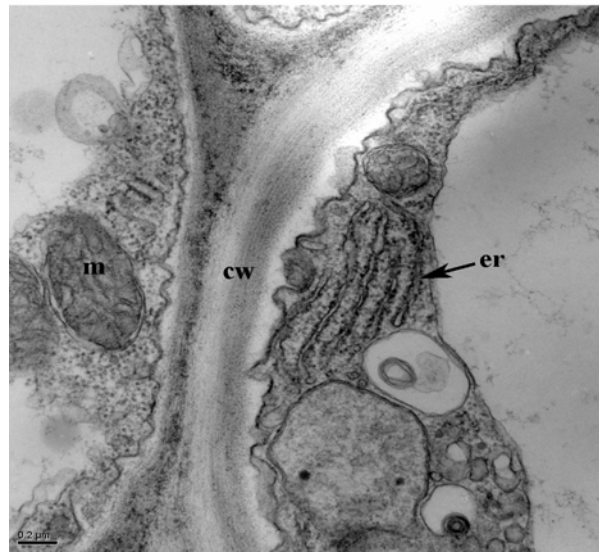

Figure 1. Transmission electron microscopy of the leaf of T<sub>1</sub> elite line: 49-4b.3.  
er: endoplasmic reticulum, cw: cell wall, g: golgi, m: mitochondria, ne: nuclear envelope.

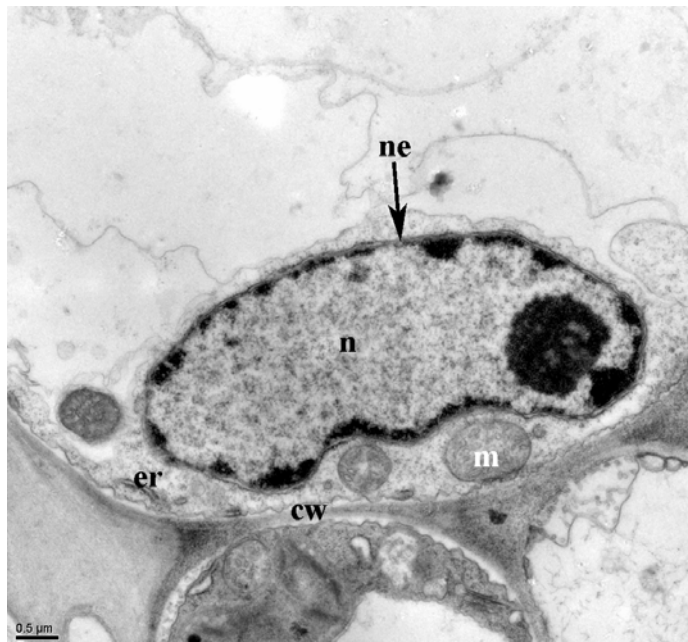
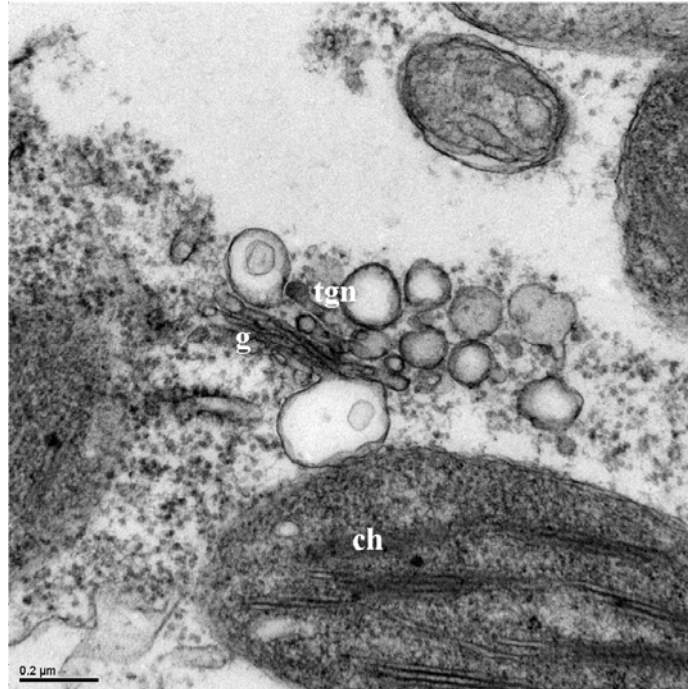

Figure 2. Transmission electron microscopy of fruit of T<sub>1</sub> elite line: 49-4b.3. ch: chloroplast, er: endoplasmic reticulum, cw: cell wall, g: golgi, tgn: trans golgi network, m: mitochondria, ne: nuclear envelope.

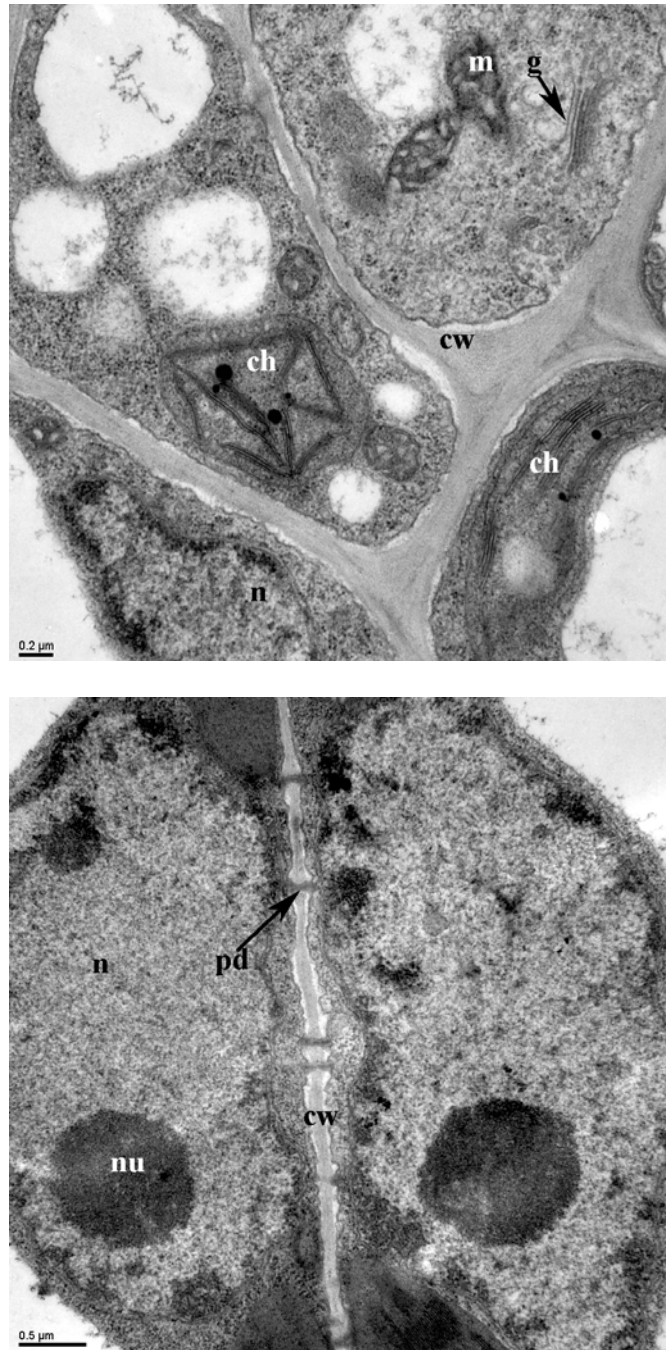

Figure 3. Transmission electron microscopy of the leaf of T<sub>1</sub> elite line: 50-7.3 leaf. ch: chloroplast, cw: cell wall, g: golgi, m: mitochondria, n: nucleus, nu: nucleolus, pd: plasmodesmata.

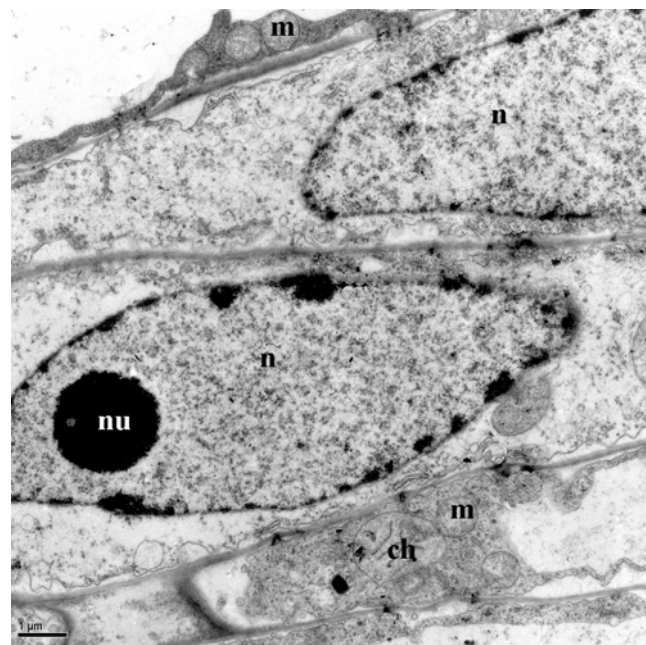
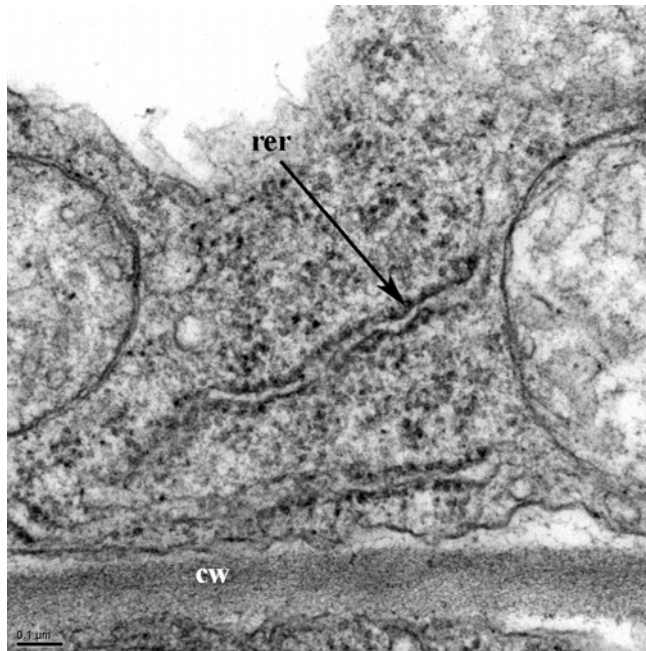

Figure 4. Transmission electron microscopy of the fruit of T<sub>1</sub> elite line: 50-7.3  
fruit. ch: chloroplast, m: mitochondria, n: nucleus, nu: nucleolus.

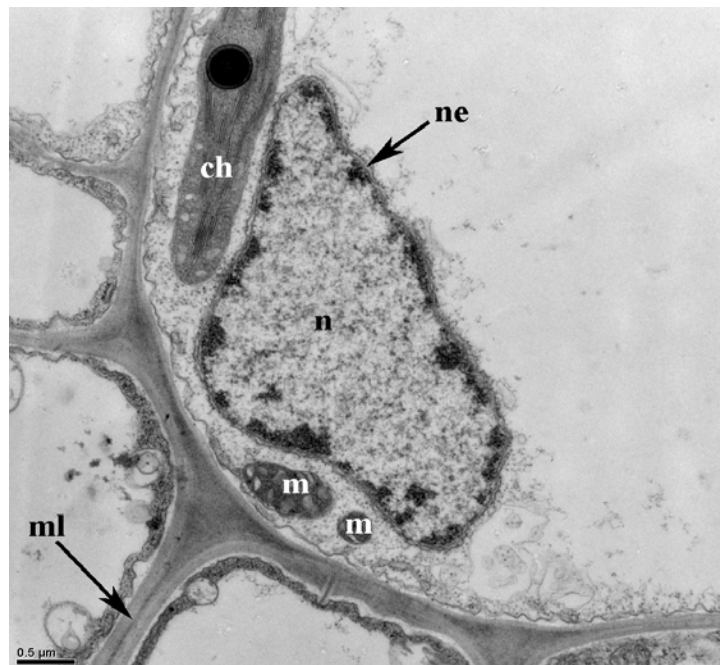
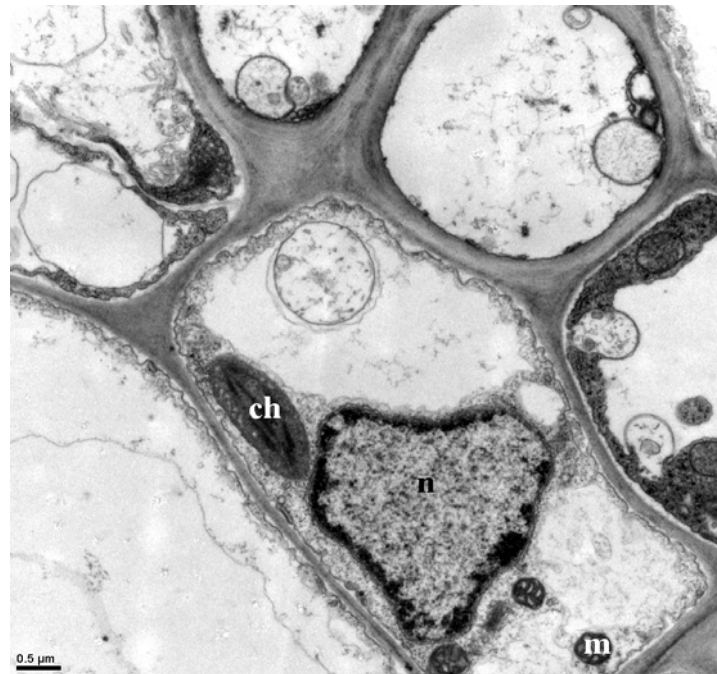

Figure 5. Transmission electron microscopy of wild type tomato leaves. ch: chloroplast, m: mitochondria, ml: middle lamella, n: nucleus, ne: nuclear envelope.



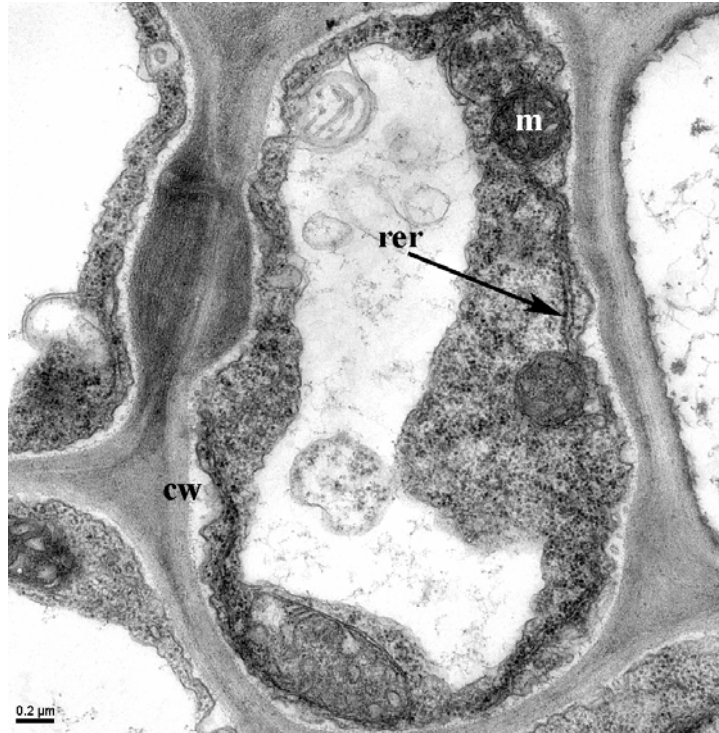

Figure 6. Transmission electron microscopy of wild type tomato fruit. m: mitochondria, n: nucleus, ne: nuclear envelope, rer: rough endoplasmic reticulum.

## CONCLUSIONS

This dissertation has focused the development of a vaccine to prevent *E. coli* O157:H7 attachment and colonization. The bacterial outer membrane protein intimin was used as a vaccine candidate, because intimin has a primary role in the intimate attachment of the *E. coli* O157:H7 to the host cell. The first step was the expression of intimin protein using plants as an expression system. The C-terminal 281 amino acids (~1/3) of the intimin protein (IntC) was expressed in tomato and the transgenic plants were tested by ELISA and Western blotting to confirm expression of antigen. Freeze-dried fruit samples that were kept at room temperature for a year showed no degradation. Therefore, this inexpensive and well-established freeze-drying technology was used to preserve the recombinant IntC from protein degradation. Plant-derived IntC was purified from the transgenic freeze-dried tomato powder. Since IntC glycosylation was reported in plant cells, we tested tomato-derived IntC for glycosylation. We observed no evidence of glycosylation in the tomato-derived IntC. The immunogenicity of IntC was tested in mice. After mice were immunized with plant-derived IntC, antigen-specific antibody responses were induced in the vaccinated animals. In addition, the duration of the bacterial shedding after the challenge with *E. coli* O157:H7 was significantly reduced in mice vaccinated with the plant-derived IntC vaccine.

Shiga toxin is produced by *E. coli* O157:H7 and it is the main cause of the HUS in humans. It is composed of an A subunit and a pentameric B subunit. The B subunit (StxB) is responsible for the binding of the toxin to its receptor, Gb3. We

designed, constructed, and expressed a fusion protein consisting of StxB and IntC (StxB1-IntC) in *E. coli*. IntC and StxB were separately expressed in *E. coli* as well. All recombinant proteins were purified and tested by Western blotting and Coomassie blue staining before their use in animal trials. The oligomeric formation of StxB was confirmed by non-denaturing SDS-PAGE, and its Gb3 binding was demonstrated. Since StxB can act as an adjuvant, the purified StxB1-IntC was expected to raise a better immune response than mice immunized with IntC or StxB1 alone. In fact, mice immunized with the StxB1-IntC fusion protein produced better serum and mucosal antibody responses than mice immunized with IntC or StxB1 alone. In addition, mice that were immunized with the StxB1-IntC fusion protein and then challenged with *E. coli* O157:H7 shed the bacteria for shorter periods than those immunized with IntC or StxB1 alone.

This study is a very important step towards developing a vaccine to prevent *E. coli* O157:H7 colonization of cattle and indirectly prevention of the infection in humans. The mucosal immune response is important for protection against intestinal infections, and we have shown that immunized mice produced mucosal antibodies.

## REFERENCES

- Agin, T. S., J. R. Cantey, et al. 1996. Characterization of the eaeA gene from rabbit enteropathogenic Escherichia coli strain RDEC-1 and comparison to other eaeA genes from bacteria that cause attaching-effacing lesions. *FEMS Microbiol Lett* 144(2-3): 249-58.
- Agin, T. S., C. Zhu, et al. 2005. Protection against hemorrhagic colitis in an animal model by oral immunization with isogeneic rabbit enteropathogenic Escherichia coli attenuated by truncating intimin. *Infect Immun* 73(10): 6608-19.
- Alvarez, M. L. and G. A. Cardineau. 2010. Prevention of bubonic and pneumonic plague using plant-derived vaccines. *Biotechnol Adv* 28(1): 184-96.
- Alvarez, M. L., H. L. Pinyerd, et al. 2006. Plant-made subunit vaccine against pneumonic and bubonic plague is orally immunogenic in mice. *Vaccine* 24(14): 2477-90.
- Amirlak, I. and B. Amirlak. 2006. Haemolytic uraemic syndrome: an overview. *Nephrology (Carlton)* 11(3): 213-8.
- Arntzen, C., S. Plotkin, et al. 2005. Plant-derived vaccines and antibodies: potential and limitations. *Vaccine* 23(15): 1753-6.
- Ashkenazi, S. and T. G. Cleary. 1989. Rapid method to detect shiga toxin and shiga-like toxin I based on binding to globotriosyl ceramide (Gb3), their natural receptor. *J Clin Microbiol* 27(6): 1145-50.
- Avery, L. M., A. P. Williams, et al. 2008. Survival of Escherichia coli O157:H7 in waters from lakes, rivers, puddles and animal-drinking troughs. *Sci Total Environ* 389(2-3): 378-85.
- Bai, J., X. Shi, et al. 2010. A multiplex PCR procedure for the detection of six major virulence genes in Escherichia coli O157:H7. *J Microbiol Methods* 82(1): 85-9
- Batchelor, M., S. Prasanna, et al. 2000. Structural basis for recognition of the translocated intimin receptor (Tir) by intimin from enteropathogenic Escherichia coli. *EMBO J* 19(11): 2452-64.
- Bavaro, M. F. 2009. Escherichia coli O157: what every internist and gastroenterologist should know. *Curr Gastroenterol Rep* 11(4): 301-6.

- Beutin, L. 2006. Emerging enterohaemorrhagic *Escherichia coli*, causes and effects of the rise of a human pathogen. *J Vet Med B Infect Dis Vet Public Health* 53(7): 299-305.
- Bielaszewska, M., I. Clarke, et al. 1997. Localization of intravenously administered verocytotoxins (Shiga-like toxins) 1 and 2 in rabbits immunized with homologous and heterologous toxoids and toxin subunits. *Infect Immun* 65(7): 2509-16.
- Bielaszewska, M. and H. Karch. 2005. Consequences of enterohaemorrhagic *Escherichia coli* infection for the vascular endothelium. *Thromb Haemost* 94(2): 312-8.
- Bradford, M. M. 1976. A rapid and sensitive method for the quantitation of microgram quantities of protein utilizing the principle of protein-dye binding. *Anal Biochem* 72: 248-54.
- Burland, V., Y. Shao, et al. 1998. The complete DNA sequence and analysis of the large virulence plasmid of *Escherichia coli* O157:H7. *Nucleic Acids Res* 26(18): 4196-204.
- Carvalho, H. M., L. D. Teel, et al. 2005. Antibody against the carboxyl terminus of intimin alpha reduces enteropathogenic *Escherichia coli* adherence to tissue culture cells and subsequent induction of actin polymerization. *Infect Immun* 73(4): 2541-6.
- Cataldi, A., T. Yevsa, et al. 2008. Efficient immune responses against Intimin and EspB of enterohaemorrhagic *Escherichia coli* after intranasal vaccination using the TLR2/6 agonist MALP-2 as adjuvant. *Vaccine*. 26(44):5662-7.
- Cherla, R. P., S. Y. Lee, et al. 2003. Shiga toxins and apoptosis. *FEMS Microbiol Lett* 228(2): 159-66.
- Choi, J. H. and S. Y. Lee. 2004. Secretory and extracellular production of recombinant proteins using *Escherichia coli*. *Appl Microbiol Biotechnol* 64(5): 625-35.
- Corrigan, J. J., Jr. and F. G. Boineau. 2001. Hemolytic-uremic syndrome. *Pediatr Rev* 22(11): 365-9.
- Dean-Nystrom, E. A., B. T. Bosworth, et al. 1998. *Escherichia coli* O157:H7 requires intimin for enteropathogenicity in calves. *Infect Immun* 66(9): 4560-3.

- Dean-Nystrom, E. A., L. J. Gansheroff, et al. 2002. Vaccination of pregnant dams with intimin(O157) protects suckling piglets from Escherichia coli O157:H7 infection. *Infect Immun* 70(5): 2414-8.
- Donnenberg, M. S., S. Tzipori, et al. 1993. The role of the eae gene of enterohemorrhagic Escherichia coli in intimate attachment in vitro and in a porcine model. *J Clin Invest* 92(3): 1418-24.
- Donohue-Rolfe, A., D. W. Acheson. et al. 1989. Purification of Shiga toxin and Shiga-like toxins I and II by receptor analog affinity chromatography with immobilized P1 glycoprotein and production of cross-reactive monoclonal antibodies. *Infect Immun* 57(12): 3888-93.
- Donohue-Rolfe, A., M. Jacewicz, et al. 1989. Isolation and characterization of functional Shiga toxin subunits and renatured holotoxin. *Mol Microbiol* 3(9): 1231-6.
- Frankel, G., D. C. Candy, et al. 1994. Characterization of the C-terminal domains of intimin-like proteins of enteropathogenic and enterohemorrhagic Escherichia coli, Citrobacter freundii, and Hafnia alvei. *Infect Immun* 62(5): 1835-42.
- Frankel, G., D. C. Candy, et al. 1995. Molecular characterization of a carboxy-terminal eukaryotic-cell-binding domain of intimin from enteropathogenic Escherichia coli. *Infect Immun* 63(11): 4323-8.
- Fremaux, B., C. Prigent-Combaret, et al. 2008. Long-term survival of Shiga toxin-producing Escherichia coli in cattle effluents and environment: An updated review. *Vet Microbiol*.
- Frenzen, P. D., A. Drake, et al. 2005. Economic cost of illness due to Escherichia coli O157 infections in the United States. *J Food Prot* 68(12): 2623-30.
- Furutani, M., K. Ito, et al. 1990. Demonstration of RNA N-glycosidase activity of a Vero toxin (VT2 variant) produced by Escherichia coli O91:H21 from a patient with the hemolytic uremic syndrome. *Microbiol Immunol* 34(4): 387-92.
- Gansheroff, L. J., M. R. Wachtel, et al. 1999. Decreased adherence of enterohemorrhagic Escherichia coli to HEp-2 cells in the presence of antibodies that recognize the C-terminal region of intimin. *Infect Immun* 67(12): 6409-17.

- Gasser, C., E. Gautier, et al. 1955. Hemolytic-uremic syndrome: bilateral necrosis of the renal cortex in acute acquired hemolytic anemia. *Schweiz Med Wochenschr* 85(38-39): 905-9.
- Ghaem-Maghani, M., C. P. Simmons, et al. 2001. Intimin-specific immune responses prevent bacterial colonization by the attaching-effacing pathogen *Citrobacter rodentium*. *Infect Immun* 69(9): 5597-605.
- Goldstein, D. A. and J. A. Thomas 2004. Biopharmaceuticals derived from genetically modified plants. *QJM* 97(11): 705-16.
- Grant, J., A. M. Wendelboe, et al. 2008. Spinach-associated *Escherichia coli* O157:H7 outbreak, Utah and New Mexico, 2006. *Emerg Infect Dis* 14(10): 1633-6.
- Guttman, J. A., Y. Li, et al. 2006. Attaching and effacing pathogen-induced tight junction disruption in vivo. *Cell Microbiol* 8(4): 634-45.
- Haicheur, N., F. Benchetrit, et al. 2003. The B subunit of Shiga toxin coupled to full-size antigenic protein elicits humoral and cell-mediated immune responses associated with a Th1-dominant polarization. *Int Immunol* 15(10): 1161-71.
- Hancock, D., T. Besser, et al. 2001. The control of VTEC in the animal reservoir. *Int J Food Microbiol* 66(1-2): 71-8.
- Haq, T. A., H. S. Mason, et al. 1995. Oral immunization with a recombinant bacterial antigen produced in transgenic plants. *Science* 268(5211): 714-6.
- Holmgren, J. and C. Czerkinsky 2005. Mucosal immunity and vaccines. *Nat Med* 11(4 Suppl): S45-53.
- Iijima, K., I. Kamioka, et al. 2008. Management of diarrhea-associated hemolytic uremic syndrome in children. *Clin Exp Nephrol* 12(1): 16-9.
- Jacewicz, M., H. Clausen, et al. 1986. Pathogenesis of shigella diarrhea. XI. Isolation of a shigella toxin-binding glycolipid from rabbit jejunum and HeLa cells and its identification as globotriaosylceramide. *J Exp Med* 163(6): 1391-404.
- Jerse, A. E. and J. B. Kaper. 1991. The eae gene of enteropathogenic *Escherichia coli* encodes a 94-kilodalton membrane protein, the expression of which is influenced by the EAF plasmid. *Infect Immun* 59(12): 4302-9.

- Jerse, A. E., J. Yu, et al. 1990. A genetic locus of enteropathogenic *Escherichia coli* necessary for the production of attaching and effacing lesions on tissue culture cells. *Proc Natl Acad Sci U S A* 87(20): 7839-43.
- Johannes, L. and W. Romer. 2010. Shiga toxins--from cell biology to biomedical applications. *Nat Rev Microbiol* 8(2): 105-16.
- Judge, N. A., H. S. Mason, et al. 2004. Plant cell-based intimin vaccine given orally to mice primed with intimin reduces time of *Escherichia coli* O157:H7 shedding in feces. *Infect Immun* 72(1): 168-75.
- Kaper, J. B., N. J.P., et al. 2004. Pathogenic *Echerichia Coli*. *Nat Rev Microbiol* 2: 123-140.
- Kapusta, J., A. Modelska, et al. 1999. A plant-derived edible vaccine against hepatitis B virus. *FASEB J* 13(13): 1796-9.
- Karch, H., M. Bielaszewska, et al. 1999. Epidemiology and diagnosis of Shiga toxin-producing *Escherichia coli* infections. *Diagn Microbiol Infect Dis* 34(3): 229-43.
- Karch, H., P. I. Tarr, et al. 2005. Enterohaemorrhagic *Escherichia coli* in human medicine. *Int J Med Microbiol* 295(6-7): 405-18.
- Karmali, M. A., M. Petric, et al. 1983. *Escherichia coli* cytotoxin, haemolytic-uraemic syndrome, and haemorrhagic colitis. *Lancet* 2(8362): 1299-1300.
- Kehl, S. C. 2002. Role of the laboratory in the diagnosis of enterohemorrhagic *Escherichia coli* infections. *J Clin Microbiol* 40(8): 2711-5.
- Keusch, G. T. and M. Jacewicz. 1975. The pathogenesis of *Shigella* diarrhea. V. Relationship of shiga enterotoxin, neurotoxin, and cytotoxin. *J Infect Dis* 131 Suppl: S33-9.
- Konowalchuk, J., J. I. Speirs, et al. 1977. Vero response to a cytotoxin of *Escherichia coli*. *Infect Immun* 18(3): 775-9.
- LeJeune, J. T., T. E. Besser, et al. 2001. Cattle water troughs as reservoirs of *Escherichia coli* O157. *Appl Environ Microbiol* 67(7): 3053-7.
- Lim, J. Y., J. Yoon, et al. 2010. A brief overview of *Escherichia coli* O157:H7 and its plasmid O157. *J Microbiol Biotechnol* 20(1): 5-14.



- Ling, H., A. Boodhoo, et al. 1998. Structure of the shiga-like toxin I B-pentamer complexed with an analogue of its receptor Gb3. *Biochemistry* 37(7): 1777-88.
- Ludwig, K., M. A. Karmali, et al. 2002. Cross-protection against challenge by intravenous *Escherichia coli* verocytotoxin 1 (VT1) in rabbits immunized with VT2 toxoid. *Can J Microbiol* 48(1): 99-103.
- Ma, J. K., P. M. Drake, et al. 2003. The production of recombinant pharmaceutical proteins in plants. *Nat Rev Genet* 4(10): 794-805.
- Maki, D. G. 2006. Don't eat the spinach--controlling foodborne infectious disease. *N Engl J Med* 355(19): 1952-5.
- Makino, K., K. Ishii, et al. 1998. Complete nucleotide sequences of 93-kb and 3.3-kb plasmids of an enterohemorrhagic *Escherichia coli* O157:H7 derived from Sakai outbreak. *DNA Res* 5(1): 1-9.
- Mason, H. S. and C. J. Arntzen. 1995. Transgenic plants as vaccine production systems. *Trends Biotechnol* 13(9): 388-92.
- Mason, H. S., J. M. Ball, et al. 1996. Expression of Norwalk virus capsid protein in transgenic tobacco and potato and its oral immunogenicity in mice." *Proc Natl Acad Sci U S A* 93(11): 5335-40.
- Mason, H. S., T. A. Haq, et al. 1998. Edible vaccine protects mice against *Escherichia coli* heat-labile enterotoxin (LT): potatoes expressing a synthetic LT-B gene. *Vaccine* 16(13): 1336-43.
- Mason, H. S., D. M. Lam, et al. 1992. Expression of hepatitis B surface antigen in transgenic plants. *Proc Natl Acad Sci U S A* 89(24): 11745-9.
- Mason, H. S., H. Warzecha, et al. 2002. Edible plant vaccines: applications for prophylactic and therapeutic molecular medicine. *Trends Mol Med* 8(7): 324-9.
- McKee, M. L., A. R. Melton-Celsa, et al. 1995. Enterohemorrhagic *Escherichia coli* O157:H7 requires intimin to colonize the gnotobiotic pig intestine and to adhere to HEp-2 cells. *Infect Immun* 63(9): 3739-44.
- McKee, M. L. and A. D. O'Brien. 1996. Truncated enterohemorrhagic *Escherichia coli* (EHEC) O157:H7 intimin (EaeA) fusion proteins promote adherence of EHEC strains to HEp-2 cells. *Infect Immun* 64(6): 2225-33.

- McNeilly, T. N., M. C. Mitchell, et al. 2010. Immunization of cattle with a combination of purified intimin-531, EspA and Tir significantly reduces shedding of *Escherichia coli* O157:H7 following oral challenge. *Vaccine* 28(5): 1422-8.
- Mead, P. S. and P. M. Griffin 1998. *Escherichia coli* O157:H7. *Lancet* 352(9135): 1207-12.
- Mead, P. S., L. Slutsker, et al. 1999. Food-related illness and death in the United States. *Emerg Infect Dis* 5(5): 607-25.
- Melton-Celsa, A. R., J. E. Rogers, et al. 1998. Virulence of Shiga toxin-producing *Escherichia coli* (STEC) in orally-infected mice correlates with the type of toxin produced by the infecting strain. *Jpn J Med Sci Biol* 51 Suppl: S108-14.
- Mestecky, J., H. Nguyen, et al. 2008. Oral immunization: an update. *Curr Opin Gastroenterol* 24(6): 713-9.
- Mett, V., C. E. Farrance, et al. 2008. Plants as biofactories. *Biologicals* 36(6): 354-8.
- Mohawk, K. L., A. R. Melton-Celsa, et al. 2010. Neutralizing antibodies to Shiga toxin type 2 (Stx2) reduce colonization of mice by Stx2-expressing *Escherichia coli* O157:H7. *Vaccine* 28(30): 4777-85.
- Mohawk, K. L., A. R. Melton-Celsa, et al. 2010. Pathogenesis of *Escherichia coli* O157:H7 strain 86-24 following oral infection of BALB/c mice with an intact commensal flora. *Microb Pathog* 48(3-4): 131-42.
- Moon, H. W., S. C. Whipp, et al. 1983. Attaching and effacing activities of rabbit and human enteropathogenic *Escherichia coli* in pig and rabbit intestines. *Infect Immun* 41(3): 1340-51.
- Mor, T. S., H. S. Mason, et al. 2004. *New generation vaccines*. NY: Marcel Dekker: 305-11.
- Nataro, J. P. and J. B. Kaper 1998. Diarrheagenic *Escherichia coli*. *Clin Microbiol Rev* 11(1): 142-201.
- O'Brien, A. D., M. R. Thompson, et al. 1977. Biological properties of *Shigella flexneri* 2A toxin and its serological relationship to *Shigella dysenteriae* 1 toxin. *Infect Immun* 15(3): 796-8.

- O'Brien, A. O., T. A. Lively, et al. 1983. Escherichia coli O157:H7 strains associated with haemorrhagic colitis in the United States produce a Shigella dysenteriae 1 (SHIGA) like cytotoxin. *Lancet* 1(8326 Pt 1): 702.
- O'Loughlin, E. V. and R. M. Robins-Browne 2001. Effect of Shiga toxin and Shiga-like toxins on eukaryotic cells. *Microbes Infect* 3(6): 493-507.
- Ochoa, T. J. and T. G. Cleary. 2003. Epidemiology and spectrum of disease of Escherichia coli O157. *Curr Opin Infect Dis* 16(3): 259-63.
- Ohmura-Hoshino, M., M. Yamamoto, et al. 2004. Non-toxic Stx derivatives from Escherichia coli possess adjuvant activity for mucosal immunity. *Vaccine* 22(27-28): 3751-61.
- Paton, J. C. and A. W. Paton. 1998. Pathogenesis and diagnosis of Shiga toxin-producing Escherichia coli infections. *Clin Microbiol Rev* 11(3): 450-79.
- Ray, P. E. and X. H. Liu. 2001. Pathogenesis of Shiga toxin-induced hemolytic uremic syndrome. *Pediatr Nephrol* 16(10): 823-39.
- Reiss, G., P. Kunz, et al. 2006. Escherichia coli O157:H7 infection in nursing homes: review of literature and report of recent outbreak." *J Am Geriatr Soc* 54(4): 680-4.
- Rigano, M. M. and A. M. Walmsley. 2005. Expression systems and developments in plant-made vaccines. *Immunol Cell Biol* 83(3): 271-7.
- Riley, L. W., R. S. Remis, et al. 1983. Hemorrhagic colitis associated with a rare Escherichia coli serotype. *N Engl J Med* 308(12): 681-5.
- Romanos, M. A., C. A. Scorer, et al. 1992. Foreign gene expression in yeast: a review. *Yeast* 8(6): 423-88.
- Safdar, N., A. Said, et al. 2002. Risk of hemolytic uremic syndrome after antibiotic treatment of Escherichia coli O157:H7 enteritis: a meta-analysis. *JAMA* 288(8): 996-1001.
- Scheiring, J., S. P. Andreoli, et al. 2008. Treatment and outcome of Shiga-toxin-associated hemolytic uremic syndrome (HUS). *Pediatr Nephrol* 23(10): 1749-60.
- Serna, A. t. and E. C. Boedeker. 2008. Pathogenesis and treatment of Shiga toxin-producing Escherichia coli infections. *Curr Opin Gastroenterol* 24(1): 38-47.

- Sheng, H., J. Y. Lim, et al. 2006. Role of Escherichia coli O157:H7 virulence factors in colonization at the bovine terminal rectal mucosa. *Infect Immun* 74(8): 4685-93.
- Shiga, K. 1898. Ueber den Erreger der Dysenterie in Japan. *Zentralbl Bakteriol Microbiol Hyg* 23: 599-600.
- Sinclair, J. F. and A. D. O'Brien. 2002. Cell surface-localized nucleolin is a eukaryotic receptor for the adhesin intimin-gamma of enterohemorrhagic Escherichia coli O157:H7. *J Biol Chem* 277(4): 2876-85.
- Sinclair, J. F. and A. D. O'Brien. 2004. Intimin types alpha, beta, and gamma bind to nucleolin with equivalent affinity but lower avidity than to the translocated intimin receptor. *J Biol Chem* 279(32): 33751-8.
- Sojikul, P., N. Buehner, et al. 2003. A plant signal peptide-hepatitis B surface antigen fusion protein with enhanced stability and immunogenicity expressed in plant cells. *Proc Natl Acad Sci U S A* 100(5): 2209-14.
- Stakenborg, T., D. Vandekerchove, et al. 2006. Protection of rabbits against enteropathogenic Escherichia coli (EPEC) using an intimin null mutant. *BMC Vet Res* 2: 22.
- Strachan, N. J., G. M. Dunn, et al. 2006. Escherichia coli O157: burger bug or environmental pathogen? *Int J Food Microbiol* 112(2): 129-37.
- Strockbine, N. A., M. P. Jackson, et al. 1988. Cloning and sequencing of the genes for Shiga toxin from Shigella dysenteriae type 1. *J Bacteriol* 170(3): 1116-22.
- Tacket, C. O. and H. S. Mason 1999. A review of oral vaccination with transgenic vegetables. *Microbes Infect* 1(10): 777-83.
- Tacket, C. O., H. S. Mason, et al. 1998. Immunogenicity in humans of a recombinant bacterial antigen delivered in a transgenic potato. *Nat Med* 4(5): 607-9.
- Tacket, C. O., M. F. Pasetti, et al. 2004. "Immunogenicity of recombinant LT-B delivered orally to humans in transgenic corn. *Vaccine* 22(31-32): 4385-9.
- Thanavala, Y., Z. Huang, et al. 2006. Plant-derived vaccines: a look back at the highlights and a view to the challenges on the road ahead. *Expert Rev Vaccines* 5(2): 249-60.
- Thanavala, Y., M. Mahoney, et al. 2005. "Immunogenicity in humans of an edible vaccine for hepatitis B." *Proc Natl Acad Sci U S A* 102(9): 3378-82.

- Tiwari, S., P. C. Verma, et al. 2009. Plants as bioreactors for the production of vaccine antigens. *Biotechnol Adv* 27(4): 449-67.
- Trofa, A. F., H. Ueno-Olsen, et al. 1999. Dr. Kiyoshi Shiga: discoverer of the dysentery bacillus. *Clin Infect Dis* 29(5): 1303-6.
- van Diemen, P. M., F. Dziva, et al. 2007. Subunit vaccines based on intimin and Efa-1 polypeptides induce humoral immunity in cattle but do not protect against intestinal colonisation by enterohaemorrhagic *Escherichia coli* O157:H7 or O26:H. *Vet Immunol Immunopathol* 116(1-2): 47-58.
- Walmsley, A. M., M. L. Alvarez, et al. 2003. Expression of the B subunit of *Escherichia coli* heat-labile enterotoxin as a fusion protein in transgenic tomato. *Plant Cell Rep* 21(10): 1020-6.
- Wen, S. X., L. D. Teel, et al. 2006a. Genetic toxoids of Shiga toxin types 1 and 2 protect mice against homologous but not heterologous toxin challenge. *Vaccine* 24(8): 1142-8.
- Wen, S. X., L. D. Teel, et al. 2006b. A plant-based oral vaccine to protect against systemic intoxication by Shiga toxin type 2. *Proc Natl Acad Sci U S A* 103(18): 7082-7.
- Wong, C. S., S. Jelacic, et al. 2000. The risk of the hemolytic-uremic syndrome after antibiotic treatment of *Escherichia coli* O157:H7 infections. *N Engl J Med* 342(26): 1930-6.
- Yoon, J. W. and C. J. Hovde. 2008. All blood, No stool: enterohemorrhagic *Escherichia coli* O157:H7 infection. *J Vet Sci* 9(3): 219-31.
- Yusibov, V., D. C. Hooper, et al. 2002. Expression in plants and immunogenicity of plant virus-based experimental rabies vaccine. *Vaccine* 20(25-26): 3155-64.
- Yusibov, V. and S. Rabindran 2008. Recent progress in the development of plant derived vaccines. *Expert Rev Vaccines* 7(8): 1173-83.

This document was generated using the Graduate College Format Advising tool. Please turn a copy of this page in when you submit your document to Graduate College format advising. You may discard this page once you have printed your final document. DO NOT TURN THIS PAGE IN WITH YOUR FINAL DOCUMENT!