

Mathematical Modeling of Systematic Treatment Implementation and Dynamics of
Neglected Tropical Diseases:

Case Studies of Visceral Leishmaniasis & Soil-Transmitted Helminths

by

Mugdha Amol Thakur

A Dissertation Presented in Partial Fulfillment
of the Requirements for the Degree
Doctor of Philosophy

Approved April 2020 by the
Graduate Supervisory Committee:

Anuj Mubayi, Chair
Ana Magdalena Hurtado
Krijn Paaijmans
Edwin Michael

ARIZONA STATE UNIVERSITY

May 2020

ABSTRACT

Neglected tropical diseases (NTDs) comprise of diverse communicable diseases that affect mostly the developing economies of the world, the “neglected” populations. The NTDs Visceral Leishmaniasis (VL) and Soil-transmitted Helminthiasis (STH) are among the top contributors of global mortality and/or morbidity. They affect resource-limited regions (poor health-care literacy, infrastructure, etc.) and patients’ treatment behavior is irregular due to the social constraints. Through two case studies, VL in India and STH in Ghana, this work aims to: (i) identify the additional and potential hidden high-risk population and its behaviors critical for improving interventions and surveillance; (ii) develop models with those behaviors to study the role of improved control programs on diseases’ dynamics; (iii) optimize resources for treatment-related interventions. Treatment non-adherence is a less focused (so far) but crucial factor for the hindrance in WHO’s past VL elimination goals. Moreover, treatment non-adherers, hidden from surveillance, lead to high case-underreporting. Dynamical models are developed capturing the role of treatment-related human behaviors (patients’ infectivity, treatment access and non-adherence) on VL dynamics. The results suggest that the average duration of treatment adherence must be increased from currently 10 days to 17 days for a 28-day Miltefosine treatment to eliminate VL. For STH, children are considered as a high-risk group due to their hygiene behaviors leading to higher exposure to contamination. Hence, Ghana, a resource-limited country, currently implements a school-based Mass Drug Administration (sMDA) program only among children. School staff (adults), equally exposed to this high environmental contamination of STH, are largely ignored under the current MDA program. Cost-effective MDA policies were modeled and compared using alternative definitions of “high-risk population”. This work optimized and evaluated how MDA along with the treatment for high-risk adults makes a significant improvement

in STH control under the same budget. The criticality of risk-structured modeling depends on the infectivity coefficient being substantially different for the two adult risk groups. This dissertation pioneers in highlighting the cruciality of treatment-related risk groups for NTD-control. It provides novel approaches to quantify relevant metrics and impact of population factors. Compliance with the principles and strategies from this study would require a change in political thinking in the neglected regions in order to achieve persistent NTD-control.

ACKNOWLEDGMENTS

I wish to express most thanks to my advisor Dr. Anuj Mubayi. He always treated me as a colleague, and welcomed and encouraged original ideas and thoughts. He has always made time to help me with my work and would regularly check in on me. At the same time, he has also been family who is and will always be there in a crisis and in celebrations. He has helped improve my overall personality as a researcher. He has been extremely patient and motivating and I wish I could multitask as well as he does some day. I am lucky to have an advisor who would go the extra mile and care so much.

I thank my parents Amol and Seema Thakur for believing in me and always being supportive and understanding. They, along with my brother Tanmay Thakur, encouraged me to aim and dream bigger and have greatest role in getting me across the globe for a Ph.D. program. They always given me more than they would have ever imagined for themselves. They have always protected me from the crazies so that I can focus on my research and not worry about anything else. I thank my fiancé Jack Pringle for being there for me during crazy and stressful periods. It is great to have someone literally drag you to your desk to work when you are not feeling self-motivated. He also gave me a home away from home. Thanks to my counselor Keiko Aoyagi to guide me through stress and motivate me to keep up. The dissertation could not have been completed without the support and input from my committee Dr. Krijn Paaijmans, Dr. Edwin Michael and Dr. Ana Magdalena Hurtado. Interactions with them have been extremely fruitful for the way I think and interpret the results in my work and overall thinking beyond just the specific research goals. I extend thanks to Dr. Pawel Bartoszczuk for introducing me to the cost analysis concepts that I used in my research. Thanks to Dr. Carlos

Castillo-Chavez, Dr. Sherry Towers and all my teachers at ASU for teaching me the methods that have been used throughout the three projects in this dissertation and other research projects.

The Simon A. Levin Mathematical, Computational and Modeling Sciences Center is filled with caring people. Sherry Woodley, Dawn Bies, Rebecca Perlin, Dr. Yun Kang, and all my colleagues have always motivated me to stay happy and focused and believed in me. Also, the friends I made through the Mathematical and Theoretical Biology Institute added to my encouragement and joy at ASU. Gabriela Navas gets a special mention for being my 3AM friend and always being there to calm me and talk sense into me whenever needed.

Most importantly, I would like to thank the School of Human Evolution and Social Change, the School of Mathematical and Statistical Sciences and the Simon A. Levin Mathematical, Computational and Modeling Sciences Center for employing me and funding my research and the Ph.D. degree program.

Lastly, thanks to all my friends and family all around for their well wishes and for being there for me. I have learned at least one good thing from each of them and I am sure that I have some part of each of them in me which makes me who I am.

TABLE OF CONTENTS

	Page
LIST OF TABLES	ix
LIST OF FIGURES	ix
CHAPTER	
1 INTRODUCTION	1
1.1 Neglected Tropical Diseases	1
1.2 Dissertation Focus	7
1.2.1 Project Summaries	10
2 TREATMENT NON-ADHERENCE AND DYNAMICS OF VISCERAL LEISHMANIASIS	17
2.1 Introduction	17
2.2 Methods	22
2.2.1 Previous VL Modeling Studies	22
2.2.2 Previous Mechanistic Treatment Non-Adherence Models	23
2.2.3 Model Description	24
2.2.4 Model-derived Novel Health Metrics	27
2.2.5	28
2.3 Mathematical Analysis	31
2.4 Results	38
2.4.1 Parameter Estimates	38
2.4.2 Results from mathematical analysis	41
2.5 Discussion	45
3 MODEL SELECTION AND ROLE OF MODEL ASSUMPTIONS FOR TREATMENT NON-ADHERENCE ON VISCERAL LEISHMANIASIS ELIMINATION	57

CHAPTER	Page
3.1	Introduction..... 57
3.1.1	WHO-led VL elimination target..... 57
3.1.2	Sandfly control interventions: 58
3.1.3	Non-Adherence to the Treatment of VL 59
3.1.4	Treatment non-adherence and case underreporting in Bihar . 60
3.1.5	Goal of this paper..... 62
3.2	Methods 63
3.2.1	<i>Data-driven non-adherence</i> model (Model I) 63
3.2.2	<i>Explicit Treatment Adherence</i> Model (Model II) 67
3.2.3	Are Model I and Model II Mechanistically Equivalent?..... 69
3.3	Results 71
3.3.1	Parameter Estimates 71
3.3.2	Bifurcation Analysis..... 76
3.3.3	Model I and Model II are Mechanistically NOT Equivalent.. 76
3.3.4	Effect of Treatment Adherence on Elimination 80
3.4	Discussion..... 85
4	RISK-STRUCTURED MASS DRUG ADMINISTRATION FOR THE CONTROL OF SOIL-TRANSMITTED HELMINTHIASIS IN GHANA . 99
4.1	Introduction..... 99
4.1.1	Epidemiology of soil-transmitted helminthiasis 99
4.1.2	Life cycle of STH 99
4.1.3	Risk factors of STH 100
4.1.4	Mass drug administration (MDA) for STH control in Ghana 101
4.1.5	Goal of the study 103

CHAPTER	Page
4.2	Methods 104
4.2.1	Summary of progression of STH modeling 105
4.2.2	Population-structuring 106
4.2.3	Modeling framework 107
4.2.4	Parameter Estimates 120
4.3	Results 124
4.3.1	Average Cost Effectiveness Ratio 124
4.3.2	Heterogeneous Mixing of High-risk Adults with Children 125
4.3.3	Incremental Cost Effectiveness Ratio 126
4.4	Discussion 131
5	DISCUSSION AND CONCLUSIONS 144
5.1	Role of mathematical modeling in a NTD control 144
5.2	VL dynamics and elimination 145
5.3	Risk-based MDA for STH control 146
5.4	Limitations 147
5.5	Challenges associated with using the modeling results 148
5.6	Conclusion: Treatment interventions are effective if risk groups are considered 152
5.7	Future work 153
	REFERENCES 161
	APPENDIX
A	VL SYMPTOMS AND TREATMENT NON-ADHERENCE DATA 180
B	MATHEMATICAL ANALYSIS FOR THE MODEL IN CHAPTER 2 182
C	PROPOSED EXTENSIONS FOR MODEL IN CHAPTER 2 191

CHAPTER	Page
D MATHEMATICAL ANALYSIS OF MODELS IN CHAPTER 3	199
E ICER RESULTS FOR CHAPTER 4	203

LIST OF TABLES

Table	Page
1.1 Contrasting Definitions of the terms “Neglected” in NTDs and “Vectors”	4
1.2 Summary of Overarching Goals and Dissertation Objectives	8
1.3 Summary of the Differences Between Micro- and Macro-parasitic In- fectious Diseases	9
2.1 Definitions of the State Variables in the Model 2.1	28
2.2 Definitions of the Parameters in the Model 2.1	29
2.3 Parameter Estimates for Model 2.1	40
3.1 Variable Description for Model I	73
3.2 Variable Description for Model II	74
3.3 Comparison of Reduced Models I and II	77
3.4 Parameter Description for Model I	78
3.5 Parameter Description and Estimates for Model II	80
4.1 Summary of population structuring used in the current work.	108
4.2 Variables Used in the Dynamical Models	111
4.3 Summary of Age- and Risk-based Strategies for MDA in Ghana.	119
4.4 Descriptions and Estimates of Parameters Used in the Dynamical Model.	123
4.5 Variable Definitions and Estimates for the Cost Model	124
4.6 Summary of ACERs (Average Cost Effectiveness Ratios) for the Best Strategies in Each Scenario as Compared to No MDA.	128
4.7 Calculating Incremental Cost-Effectiveness and Identifying Dominated Alternatives	130
5.1 Summary of Novel Theoretical Understandings in This Dissertation for Modeling of NTDs	152

A.1 Data from (4) for Health-Facility Wise Treatment Non-Adherence and VL Prevalence	181
---	-----

LIST OF FIGURES

Figure	Page
2.1 Flow of Treatment Access and Behaviors.	19
2.2 Average VL Prevalence in Endemic Sub-Districts in Southeast Asian Region and Respective Average Treatment Non-Adherence	20
2.3 Examples of Previous Disease Models with Treatment Non-Adherence .	23
2.4 Flowchart of the Vector-Host Model for VL Dynamics with Exponen- tially Distributed Treatment Non-Adherence	26
2.5 Histogram of Percentage of Treatment Defaulters Over the Treatment Duration	30
2.6 Flow of the Mathematical Analysis of the Model 2.1	32
2.7 Minimizing χ^2 Statistic to Estimate Treatment Adherence Proportion .	39
2.8 Model Estimate of the Number of Patients for Treatment Adherence Proportion of 0.82 (Best-Fit)	41
2.9 Reproduction Number Threshold Curve for Model 2.1	43
2.10 Underreporting of VL Prevalence Based on Treatment Non-Adherence .	43
2.11 Endemic VL Incidence Based on Treatment Non-Adherence	44
2.12 Additional VL Incidence Due to Treatment Non-Adherence	45
3.1 Flowchart of Behavioral Aspects in Treatment and Health-Seeking.....	62
3.2 Percent Defaulters at Different Stages During the Treatment	63
3.3 Exponential- and Gamma-Distributed Probability of Leaving Treat- ment	65
3.4 <i>Data-driven Non-adherence Model: Stage Progression Model for VL</i> Dynamics with Gamma-Distributed Treatment Non-Adherence	66

Figure	Page
3.5 <i>Explicit Treatment Adherence Model</i> : Flowchart of VL Dynamics with Explicit Incorporation of Treatment Non-Adherers and with Vector Control.	68
3.6 Flowchart of Model II with No Vector Control. That is $\delta_V = 0$, $\psi = 0$ and $\epsilon = 1$ in Figure 3.1	72
3.7 Flowchart of the Reduced Model I.	72
3.8 Flowchart of the Reduced Model II.	73
3.9 Elimination of VL from Bihar by 2021 Depending on Treatment Non-Adherence	81
3.10 Underreporting of VL Cases Due to Treatment Non-Adherence	82
3.11 Reproduction Number Threshold for Model II Based on Treatment Non-Adherence, Rate of Resuming Treatment after Non-Adherence and Infectivity of Non-Adherent Population	83
3.12 Normalized Sensitivity Indices for R_0 for Various Parameters in Model II.	84
3.13 Reduction in VL Prevalence Based on Different Combinations of Vector Controls and Treatment Adherence	85
3.14 Effect of Treatment Access Rate, Proportion of Perfect Treatment Adherence, Proportion of Treatment Adherence by Defaulters and Rate of Restarting the Treatment after Defaulting on the VL Prevalence	86
3.15 Elimination of VL from Bihar by 2021 with Current Vector Control ...	87
4.1 Life Cycle and Mode of Transmission of Helminths (Hookworm)(5; 7) ..	100
4.2 Prevalence of STH in Ghana for Different Helminth Species	102
4.3 Flowchart of Analyses	108

Figure	Page
4.4 ACER for Different Coverages of Children and High-Risk Adults in MDA	126
4.5 Comparison of the Effect of Best Strategies (Based on ACER) for All Scenarios of MDA.....	127
4.6 Cost-effectiveness Frontier	129
5.1 Sociocultural Aspects in Agent-based Model of Sattenspiel et. al. (2019) (23)	150
C.1 Treatment Non-Adherence as a Saturating Function of VL Prevalence .	193
C.2 Flowchart of the Side-Effect Structured Non-Adherence in VL Transmission Dynamics Model	194
C.3 Schematic Representation of Distribution of Non-Adherence to Treatment for People with Adverse Side-Effects	194
C.4 Schematic Representation of Distribution of Non-Adherence to Treatment for People with Milder Side-Effects.....	195
C.5 Treatment Non-Ndherence as Function of Infected Sandfly Density	195
C.6 Schematic Plot of Seasonal Treatment Adherence due to Reduced Access to Health-Care Facility During the Monsoon.	196
C.7 Schematic Plot of Seasonal Treatment Adherence due to Reduced Access to Health-Care Facility Updated for Different Period of Seasonality During the Monsoon.....	197
E.1 Cost-Effectiveness Plane of All Scenarios with the Cost-effective Frontier Represented in Red Curve.	204

Chapter 1

INTRODUCTION

1.1 Neglected Tropical Diseases

What are Neglected Tropical Diseases (NTDs)?: NTDs are the ancient diseases of poverty most common in low-income populations and are endemic in 149 countries with different factors such as cultures, economies, infrastructures and climates shaping their patterns (1; 2). World Health Organization list 20 diseases as NTDs which urgently need prioritization: bacterial (Buruli ulcer, Endemic treponematoses (Yaws), Leprosy, Trachoma), protozoan (Chagas disease, Leishmaniasis, Human African trypanosomiasis), viral (Dengue and Chikungunya fever, Rabies), helminthic (Echinococcosis, Foodborne trematodiasis, Lymphatic filariasis, Onchocerciasis, Schistosomiasis, Soil-transmitted helminthiasis, Dracunculiasis, Taeniasis/cysticercosis), Chromoblastomycosis and other deep mycoses, Scabies and Snakebite envenoming (3). Although NTDs are affecting daily life of more than 1.4 billion people around the world, they receive less funding and attention as compared to other infectious diseases like Tuberculosis and HIV, hence the name *neglected*. Even in developed countries, NTDs affect the poorest populations (4). The NTDs may have come to light (i.e. may be attributed to be less neglected in the current time) due to the implementation of global programs to tackle them. Therefore, I have presented various arguments in Table 1.1 to initiate the discussion on what will make the NTDs to stop being neglected in the future. WHO believes that the control of NTDs will result in reducing problems from multiple ends including “illness, social exclusion and

mortality”, which then will directly contribute to the development of the resource limited countries (1).

Health, Economic and Social Effect of NTDs:

- *Health effect:* NTDs impact populations in various ways such as malnourishment, growth impairment, co-infections with deadlier diseases, permanent disability, morbidity, and mortality. In some cases, NTDs can cause serious disabilities like blindness (Onchocerciasis and Trachoma), disfigurement (Lymphatic Filariasis, Leishmaniasis, Leprosy, and Buruli ulcer), and are often eventually life-threatening (African trypanosomiasis, Chagas disease, Dengue fever, and Schistosomiasis) (5).
- *Economic effect:* NTDs can cause families to enter into deep poverty traps or financial ruin due to costly treatment (which may be a result of poor investment return for the pharmaceutical companies). Moreover, it is well documented that NTDs are costing developing economies billions of dollars annually.
- *Social effect:* Social stigma, poor mental health, absenteeism in school and life quality are some of the direct social effects of NTDs. For example, stigma, defined as a social process characterized by exclusion, rejection, blame or devaluation of an individual by a person or group, is extremely common in many parts of the affected world.

WHO’s efforts for prevention, control, elimination and eradication of NTDs

Prevention and eradication becomes critically important because continuity “of the appalling stigma, disfigurement, blindness and disabilities caused by NTDs.” The possibility of eliminating or eradicating Dracunculiasis, Leprosy, Lymphatic Filariasis, Onchocerciasis, Trachoma, sleeping sickness, Visceral Leishmaniasis, and canine

rabies within the next ten years was the principal aim of the London Declaration on Neglected Tropical Diseases, which is a collaborative effort involving the WHO, the World Bank, the Bill & Melinda Gates Foundation, the world's 13 leading pharmaceutical companies, and government representatives from US, UK, United Arab Emirate, Bangladesh, Brazil, Mozambique and Tanzania (6). This meeting was primarily evolved in 2012 in order to mitigate the burden of NTDs. The efforts include mass deworming, integrated vector management, WASH (Water, sanitation and hygiene) interventions, investment in research and development for new diagnostics, drugs and vaccines, provision of drugs for treatment with a discount or free of cost, active and passive case detection, mass drug administration etc. The elimination or even eradication for some diseases were thought to be possible because of the presence of single host species, accurate diagnostic method, effective treatment, etc. For example, feasibility of eliminating Visceral Leishmaniasis from the South-east Asian region is attributed to humans being the only known reservoirs and infecting sandfly species being susceptible to the insecticides; STH can be potentially controlled and reduced to the level of no public health significance due to the availability of a safe and single-dose preventive drug (3).

Risk factors and populations: A wide range of human- and environment-sourced factors such as travel behavior, societal influences, pathogen evolution and adaptation, economy status, capacity of public health system, etc. lead to the emergence and persistence of NTDs (7). The other common risk factors are immuno-suppression, contaminated water, living conditions (e.g. vectors live in the cracks of mud houses), sanitary human behavior and compliance to interventions etc. (8). Risk factors are broadly categorized into the categories such as water, sanitation and household re-

Term	Arguments/Attributes/Definitions	
	What the term is	What the term isn't
"Neglected" Tropical Diseases	<p>"Neglected" because,</p> <ul style="list-style-type: none"> • Affected populations are neglected • Affect the world's poor • Historically haven't received much attention (despite most of them having affecting populations for centuries) • Aimed population coverage for interventions hard to reach 	<p>NOT "neglected" anymore because,</p> <ul style="list-style-type: none"> • Global initiatives for control, elimination and eradication implemented for past twenty years. • Commitments to ensure 'No one is left behind' to achieve Sustainable Development Goals • Significant progress towards achieving WHO's goals for their control.
Vectors	<ul style="list-style-type: none"> • Any agent that carries and transmits infectious pathogens into another living organism. • Inanimate object like dust sometimes attributed as vector 	<ul style="list-style-type: none"> • The agent carrying pathogen is NOT infected. • Non-living host or environmental reservoir not attributed as vector.

Table 1.1: Arguments on attributions of NTDs being neglected and what constitutes an epidemiological vector.

lated, socio-cultural, poverty, environmental and migration (9) so that the challenges faced in controlling the NTDs can be addressed systematically.

On the other hand, some of the NTDs are transmitted by distinct and/or multiple transmission modes. Hence, based on transmission routes, spread of NTDs is closely related to human behaviors that in turn are related to sanitation and hygiene practices (10). Since the affected communities are often hard-to-reach and affected regions are resource-limited (poor health-care infrastructure and access, health and treatment illiteracy, etc), patients' treatment behavior is irregular (late access to health care, non-adherence to treatment, non-compliance with the preventive interventions etc.) as it also depends on other social constraints of individuals. These risky behaviors pose a challenge to NTD control since the effectiveness of the efforts is conditional on the communities' cooperation.

Public Health Surveillance: *Surveillance* is defined as “the ongoing systematic collection, analysis, and interpretation of health data” (11). It has been identified as an important intervention tool. One of the strategies by WHO for NTD control is improved surveillance since it would lead to monitoring of disease prevalence as well as the effect of the interventions. It also provides a good source for identification of critical factors for disease transmission, dynamics of patient follow-up, outbreaks, and failure of treatment (if any) (12). However, implications of surveillance are only as good as its implementation. Many countries (especially developing countries) lack robust disease surveillance systems due to insufficient resources, inadequate public health capacity, and outdated or poor health information systems (13). The major population that is unreported in the surveillance are the asymptomatic cases, people who do not access health-care, people who do not go to public health systems for diagnosis and/or treatment and false negatives due to suboptimal performance of diagnostic tests (14). Due to this underreporting, the projections and interventions could end up being inadequate and thus lead to failure of NTD control, elimination or eradication goals. Moreover, the passive collection of data by the health surveillance system often fails to continue to follow up on reported cases, leading to leakage information and preventable further transmission of infection.

Progress of the WHO interventions Although significant progress has been achieved towards the goals for many of these NTDs, there has been minimal gains for 4 diseases: Trichuriasis, Hookworm disease, Food-borne trematodiasis, and Cystic echinococcosis. Furthermore, for Dengue and other arbovirus infections such as Leishmaniasis and Chagas disease, we are “Losing the battle” (as suggested by well known tropical disease scientist Prof. Peter Hotez) (15).

Social Science and NTDs: Although the NTDs have been targeted for control since the mid-2000s, the status of the role of social science research is still neglected (16). There are enough funded social science research projects, but integrating their results into policy decisions needs to be made better (17). Therefore, it becomes important to involve the community directly to effectively use the outcomes from scientific research for enhancing intervention outcomes (18).

Mathematical models for NTDs control: Mathematical tools have been used to model infectious diseases to understand transmission dynamics and perform predictions which are helpful in informing policies to control them. The first known use of mathematical modeling for smallpox spread and treatment was used by Bernoulli (1766). The concept of using compartmental models for infectious diseases was introduced in the early 1900s by a series of researchers, including Hamer, Ross, McKendrick and Kermack (19).

Mathematical models have been playing an important role in modeling and identifying major pathways of transmissions of NTDs, evaluating their control and/or elimination targets, validating novel strategies and optimizing them (20). Some of the published mathematical modeling studies which have impacted the NTDs control and elimination programs are collected by NTD Modeling Consortium and can be found at <https://www.biomedcentral.com/collections/ntdmodels2015>. Mathematical models have an advantage in addressing the control of these “neglected” diseases as modeling is not bound by limitations posed by sparse data or infrastructure funding (21).

1.2 Dissertation Focus

Overview of dissertation: For many NTDs, treatment is the foremost intervention and can play a significant role in mitigating their burden if implemented effectively. However, in reality it is accompanied by some major challenges. There are multiple reasons why the treatment might fail at a population level – treatment non-adherence (due to initial healing of patients and public health illiteracy), poverty, access to treatment facilities, inadequate surveillance which lacks follow-up to know accurate completion of treatment, systematic non-adherence etc. Also, in case of an outbreak, usually the focus is on intense active case detection which is not always affordable for the resource-poor countries. Therefore, **this work attempts to identify hidden novel characteristics of population behaviors (particularly with respect to treatment implementation) in order to significantly improve existing control programs (and likelihood of potential elimination of a disease) for two ecologically and epidemiologically contrasting diseases and places: VL in India and STH in Ghana. Moreover, it aims to study disease dynamics due to changes in these hidden characteristics of human behaviors via development of new modeling frameworks.**

The specific goals of this work are to (i) identify high-risk population and their behaviors that have been neglected but are critical for implementing improved interventions and/or surveillance, (ii) develop novel dynamical models with identified high-risk population and behaviors in order to study the role of control programs related to high-risk populations on the dynamics of VL and STH, and (iii) suggest effective policies that can simultaneously optimize disease burden and public health resources over time.

	<u>VL</u>	<u>STH</u>
Overachieving goals	How can VL be eliminated in India? (Unable to meet WHO's previous target dates)	How can STH control target in Ghana be met? (in spite of regular MDA since 2000)
Novelty	Identified that group of treatment non-adherers , which are not part of current surveillance, may be critical subpopulation.	Identified that school staff (adults with higher risk of exposure to contamination), not covered in children-targeted MDA, may be a critical subpopulation.
Objectives	Develop a data-driven dynamical transmission model to estimate 1. Current treatment non-adherence level in India 2. Critical treatment adherence level to eliminate VL in the presence of existing interventions and budget	Develop dynamical transmission and cost models to: 1. Compare the effects of age- and risk-structured MDA strategies. 2. Find the most cost-effective policies in the two strategies.

Table 1.2: Summary of Overarching Goals and Dissertation Objectives

Highest global DALYs are attributed to helminthic infections with STH leading the list, whereas highest DALYs among protozoan NTDs are due to Leishmaniasis (22; 8; 23). The two case studies- VL in India and STH in Ghana - are chosen and studied here with the aim of addressing above-mentioned goals. VL is a *microparasitic* disease and is spread to humans by *sandflies* whereas STH is a *macroparasitic* disease and transmitted through *contaminated environment (soil)*. The summary of differences between micro- and macro-parasitic infectious diseases are presented in Table 1.3. Note that STH may be considered to be vector-borne in a philosophical sense; refer Table 1.1 for the attributes of an epidemiological vector. Control-wise perspective, VL is categorized into innovative and intensified disease management (that is, enhancement of NTD control within primary health-care by combining expertise in disease-specific areas with cross-cutting issues such as surveillance, capacity building, advocacy and research) and STH into preventative chemotherapy and transmission control (that is, an emphasis on a coordinated, cost-effective approach to the implementation of national elimination and control activities where preven-

Microparasitic diseases	Macroparasitic diseases
<p>Example: Visceral Leishmaniasis</p> <p>Microparasites multiply and develop quickly within host(s)</p> <p>Number of infected individuals is critical</p> <p>Population level model with Units as individual</p> <p>Typical compartmental transmission model looks like</p> 	<p>Example: Soil-transmitted helminthiasis</p> <p>Developmental stages (larvae) can be free-living</p> <p>Distribution of parasites per host is important</p> <p>Population level model with Units as pathogen</p> <p>Typical compartmental transmission model looks like</p> 

Table 1.3: Summary of the Differences Between Micro- and Macro-parasitic Infectious Diseases

tive chemotherapy is the main tool; e.g. regular antihelminthic drug administration). Thus, the dissertation will broadly cover a representative group for most NTDs, primarily described as a main three projects in this dissertation. The overarching goals, novelties and objectives for the two diseases, VL and STH, are summarized in Table 1.2. For VL in India, the potential, but currently hidden from the surveillance, high-risk group is the treatment non-adherers. This group of population gets inaccurately reported as treated due to lack of thorough follow-up while still spreading the infection; thereby being a hidden source of infections. For STH in Ghana, hookworm

disease is the most prevalent helminthic infection and MDA efforts do not seem to decrease STH prevalence as effectively as for Lymphatic Filariasis and Onchocerciasis (24). Although the current MDA in Ghana for STH is focused on administering drug to school-age children, it has been seen that the hookworm prevalence is equivalently high for population with age greater than 15 years (25). Since school-based MDA are shown to be cost-effective before, incorporating adults at schools in this policy may be considered. These adult sub-population are potentially high-risk since they spend half of their time among the highly prevalent school children. Them sharing the latrines and surfaces touched by high density of children exposes them to higher contamination risk for hookworm infections.

This dissertation consists of five chapters. The current Chapter 1 introduces the topic of NTDs and provides relevant terminology in the field and overall research goals of the dissertation. The three novel projects are described in Chapters 2 to 4 whereas final Chapter 5 concludes with overall implications from this dissertation as well as limitations and future directions. The specific goals addressed and studied through three main projects in this dissertation are described below in more detail.

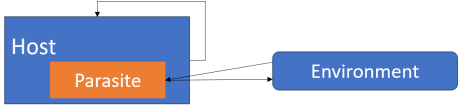
1.2.1 Project Summaries

Project 1 (Described in Chapter 2): In spite of VL being fatal if not treated, treatment adherence in Bihar, India is not perfect. It can be seen from limited data that in regions with lower treatment adherence, the VL prevalence is higher. However due to scarcity of data and inadequate follow-up of patients, it is difficult to understand the impact of this group, which seems to be contributing significantly towards disease burden. Treatment adherence has been previously studied for some directly-transmitted diseases like tuberculosis and leprosy. Inspired by that, I developed a novel mathematical vector-host-type VL outbreak model to estimate average treat-

ment non-adherence in Indian state of Bihar and to study its effect, in combination with varying treatment access rate and patients' infectivity, on the VL transmission dynamics and endemicity levels.

Project 2 (Described in Chapter 3): To eliminate VL from Bihar, WHO and the Indian government have implemented sophisticated vector control programmes which have either reduced vector biting rates, larval density or vector density itself. However, in spite decades of control efforts through the vector control programs, India has been unable to reach its elimination target goals. In this work, I have used mathematical models to analyze and evaluate the time to elimination if the treatment adherence was increased when vector control programs are implemented at the current rates. Since the data on population treatment behaviors are scarce, in this project, I also studied the role of different assumptions related to the distribution of treatment non-adherence. In particular, two models are developed assuming two different types of treatment non-adherence distributions (exponential vs gamma) in the population since the treatment non-adherence mechanism is not fully explored yet. I also quantify the effect of increasing treatment adherence in presence of different vector controls on the reduction in VL incidence. This is done with an aim to assess which vector control works best in combination increasing treatment adherence in the case if resources were limited and implementation of not all the vector controls were feasible.

Project 3 (Described in Chapter 4): STH is a directly transmitted macroparasitic disease with a worldwide prevalence of around 24%. STH has the highest prevalence in sub-Saharan Africa wherein Ghana has an above global average prevalence of 25.4%. To control STH in Ghana, WHO has been implementing at least an

annual mass drug administration with an aim to cover 75% of the children population, considered as the high-risk group for STH. The popular treatment (both curative and preventative) for STH is a single dose of Albendazole in Ghana. Single dose, leads to no non-adherence as long as the people have access to it during MDA. The disease has not been controlled even after almost 20 years of MDA. For some other countries, it has been shown that community-based MDA may not be cost-effective especially in resource limited countries like Ghana. In this work, I developed novel sets of mathematical models and carried out model-based cost-effectiveness analysis to compare the impact of community-based MDA with that of risk-based MDA with the assumption that the school workers and officials were the high risk populations (currently ignored in MDA implementation in Ghana) that could be covered in school-based MDA.

We have been knowing about Neglected tropical diseases (NTDs) for at least a century but it has not been given due attention and hence, we have been unable to eliminate it. Through this dissertation, I have hoped to provide some novel intervention strategies for VL and STH that might be a game changer in achieving elimination targets set by WHO. The strategies and methods discovered are novel and appropriate for poor settings like seen in India or Ghana. The suggested strategies here are different from the traditional public health view perspective that have been taken until now for these two NTDs. In this dissertation, I provide frameworks for real time evaluations of suggested strategies. However, as with any other modeling studies, this work also requires additional data to validate its results, which is kept for future work. Moreover, eradicating these diseases will require a multi-pronged approach including drug administration, health education, vector control and clean sanitation facilities,

which in turn will require a high level of local government commitment along with strong partnerships among major stakeholders.

REFERENCES

- [1] W. H. Organization *et al.*, “Working to overcome the global impact of neglected tropical diseases: first who report on neglected tropical diseases: update 2011,” 2011.
- [2] W. H. Organization *et al.*, “Ending the neglect to attain the sustainable development goals,” 2020.
- [3] W. H. Organization *et al.*, “Global plan to combat neglected tropical diseases 2008-2015,” tech. rep., Geneva: World Health Organization, 2007.
- [4] P. J. Hotez, “Ntids v. 2.0: “blue marble health”—neglected tropical disease control and elimination in a shifting health policy landscape,” *Plos Neglected Tropical Diseases*, vol. 7, no. 11, 2013.
- [5] Y. Zhang, C. MacArthur, L. Mubila, and S. Baker, “Control of neglected tropical diseases needs a long-term commitment,” *BMC medicine*, vol. 8, no. 1, p. 67, 2010.
- [6] U. to Combat NTDs, “London declaration on neglected tropical diseases,” 2012.
- [7] T. K. Mackey, B. A. Liang, R. Cuomo, R. Hafen, K. C. Brouwer, and D. E. Lee, “Emerging and reemerging neglected tropical diseases: a review of key characteristics, risk factors, and the policy and innovation environment,” *Clinical microbiology reviews*, vol. 27, no. 4, pp. 949–979, 2014.

- [8] A. K. Mitra and A. R. Mawson, “Neglected tropical diseases: epidemiology and global burden,” *Tropical medicine and infectious disease*, vol. 2, no. 3, p. 36, 2017.
- [9] J. Aagaard-Hansen, C. L. Chagnat, *et al.*, “Neglected tropical diseases: equity and social determinants,” *Equity, social determinants and public health programmes*, vol. 135, 2010.
- [10] K. I. C. Ong, H. Araki, S. Kano, and M. Jimba, “The potential of positive deviance approach for the sustainable control of neglected tropical diseases,” *Tropical medicine and health*, vol. 44, no. 1, p. 20, 2016.
- [11] X.-N. Zhou, R. Bergquist, and M. Tanner, “Elimination of tropical disease through surveillance and response,” 2013.
- [12] E. Tambo, L. Ai, X. Zhou, J.-H. Chen, W. Hu, R. Bergquist, J.-G. Guo, J. Utzinger, M. Tanner, and X.-N. Zhou, “Surveillance-response systems: the key to elimination of tropical diseases,” *Infectious diseases of poverty*, vol. 3, no. 1, p. 17, 2014.
- [13] T. T. F. for Global Health, “Disease surveillance,” Accessed April 2020.
- [14] C. L. Gibbons, M.-J. J. Mangen, D. Plass, A. H. Havelaar, R. J. Brooke, P. Kramarz, K. L. Peterson, A. L. Stuurman, A. Cassini, E. M. Fèvre, *et al.*, “Measuring underreporting and under-ascertainment in infectious disease datasets: a comparison of methods,” *BMC public health*, vol. 14, no. 1, p. 147, 2014.
- [15] P. Hotez and S. Aksoy, “Plos neglected tropical diseases: Ten years of progress in neglected tropical disease control and elimination... more or less,” 2017.

- [16] K. Bardosh, “Global aspirations, local realities: the role of social science research in controlling neglected tropical diseases,” *Infectious diseases of poverty*, vol. 3, no. 1, p. 35, 2014.
- [17] S. Madon, M. N. Malecela, K. Mashoto, R. Donohue, G. Mubyazi, and E. Michael, “The role of community participation for sustainable integrated neglected tropical diseases and water, sanitation and hygiene intervention programs: A pilot project in tanzania,” *Social Science & Medicine*, vol. 202, pp. 28–37, 2018.
- [18] S. Pokhrel, D. Reidpath, and P. Allotey, “Social sciences research in neglected tropical diseases 3: Investment in social science research in neglected diseases of poverty: a case study of bill and melinda gates foundation,” *Health research policy and systems*, vol. 9, no. 1, p. 2, 2011.
- [19] F. Brauer, “Mathematical epidemiology: Past, present, and future,” *Infectious Disease Modelling*, vol. 2, no. 2, pp. 113–127, 2017.
- [20] T. D. Hollingsworth, E. R. Adams, R. M. Anderson, K. Atkins, S. Bartsch, M.-G. Basáñez, M. Behrend, D. J. Blok, L. A. Chapman, L. Coffeng, *et al.*, “Quantitative analyses and modelling to support achievement of the 2020 goals for nine neglected tropical diseases,” *Parasites & vectors*, vol. 8, no. 1, p. 630, 2015.
- [21] A. Kealey *et al.*, “Neglected tropical diseases: infection, modeling, and control,” *Journal of health care for the poor and underserved*, vol. 21, no. 1, pp. 53–69, 2010.

- [22] P. J. Hotez and A. Kamath, “Neglected tropical diseases in sub-saharan africa: review of their prevalence, distribution, and disease burden,” *PLoS neglected tropical diseases*, vol. 3, no. 8, 2009.
- [23] Z. A. Bhutta, J. Sommerfeld, Z. S. Lassi, R. A. Salam, and J. K. Das, “Global burden, distribution, and interventions for infectious diseases of poverty,” *Infectious diseases of poverty*, vol. 3, no. 1, p. 21, 2014.
- [24] P. J. Hotez, N.-K. Biritwum, A. Fenwick, D. H. Molyneux, and J. D. Sachs, “Ghana: Accelerating neglected tropical disease control in a setting of economic development,” *PLoS neglected tropical diseases*, vol. 13, no. 1, 2019.
- [25] D. Humphries, E. Mosites, J. Otchere, W. A. Twum, L. Woo, H. Jones-Sanpei, L. M. Harrison, R. D. Bungiro, B. Benham-Pyle, L. Bimi, *et al.*, “Epidemiology of hookworm infection in kintampo north municipality, ghana: patterns of malaria coinfection, anemia, and albendazole treatment failure,” *The American journal of tropical medicine and hygiene*, vol. 84, no. 5, pp. 792–800, 2011.

Chapter 2

TREATMENT NON-ADHERENCE AND DYNAMICS OF VISCERAL LEISHMANIASIS

2.1 Introduction

Epidemiology of VL : Visceral Leishmaniasis (VL) is a neglected tropical disease with an estimated 50,000 to 90,000 new cases and over 20,000 to 40,000 deaths annually worldwide. In 2015, more than 90% of new cases reported to WHO occurred in 7 countries: Brazil, Ethiopia, India, Kenya, Somalia, South Sudan and Sudan (1). VL, if not diagnosed and treated, is fatal in 95% cases (2) and is second in causing maximum deaths per year after Malaria.

Causes of VL : In India, VL is caused by the parasite *Leishmania donovani*. It is transmitted to humans through the insect vectors Phlebotomine sandflies which are tiny in size (about 3-6mm long and 1.5-3mm in diameter). Phlebotomine sandflies occur throughout the tropics and sub-tropics, as well as in temperate zones. The lifecycle of this *Leishmania* parasite is completed partly in sandfly and partly in humans. Adult female sandflies pick up the parasite through the peripheral tissues by biting an infected individual for blood-sucking. The parasite reproduces asexually in the sandfly's alimentary canal and proceeds to its gut for regurgitational transmission. The parasite is introduced to humans locally at the infected sandfly's bite location which then spreads infection to its liver and spleen (3; 4). For a more detailed life cycle of *Leishmania*, refer to (5; 6; 7).

Treatment for VL: Miltefosine (MIL) is the only oral drug known to treat VL in India. MIL 28-day monotherapy has been recommended to be the first-line treatment regime to treat VL in India (8). Because of improper private practices and availability of the drug over the counter, drug failure and potential resistance has arisen as challenges. Additionally, due to the limited supply of the drug, the weekly dosage is now made available to patients only through public hospitals (9). The long duration of treatment, difficult access to the drug and side-effects are leading to increased treatment non-adherence in the population. Treatment non-adherence with a lack of a systematic follow-up and surveillance of patients leads to inaccuracy in reports of disease status: over-reporting of treatment completion and under-reporting of total cases (since non-adherent patients are assumed to be treated); thereby making policy recommendations improperly informed.

Definition of treatment adherence In general, *adherence* is defined as the extent to which patients are able to follow the recommendations for prescribed treatments (10). Non-adherence may constitute of– not seeking treatment upon diagnosis of infection, permanently stopping the treatment midway or inconsistency in taking doses exactly as prescribed. Studies use different terms for non-adherence like *defaulting*, *non-compliance* to be defined differently for the respective studies. Kansal et. al. (2017) define *defaulting* as discontinuation of treatment from a particular PHC (public health center) (11) while Uranw et. al. (2013) define it as not following up with the treatment until 2 days later than the expected day (12). The general flow of treatment access and treatment behaviors can be seen in the Figure 2.1.

Treatment non-adherence is usually studied for long-term therapies for diseases like Asthma, Depression, Cancer, HIV/AIDS, Tuberculosis, Diabetes, Epilepsy, Hypertension and Tobacco Cessation (13). Although most of these are non-communicable

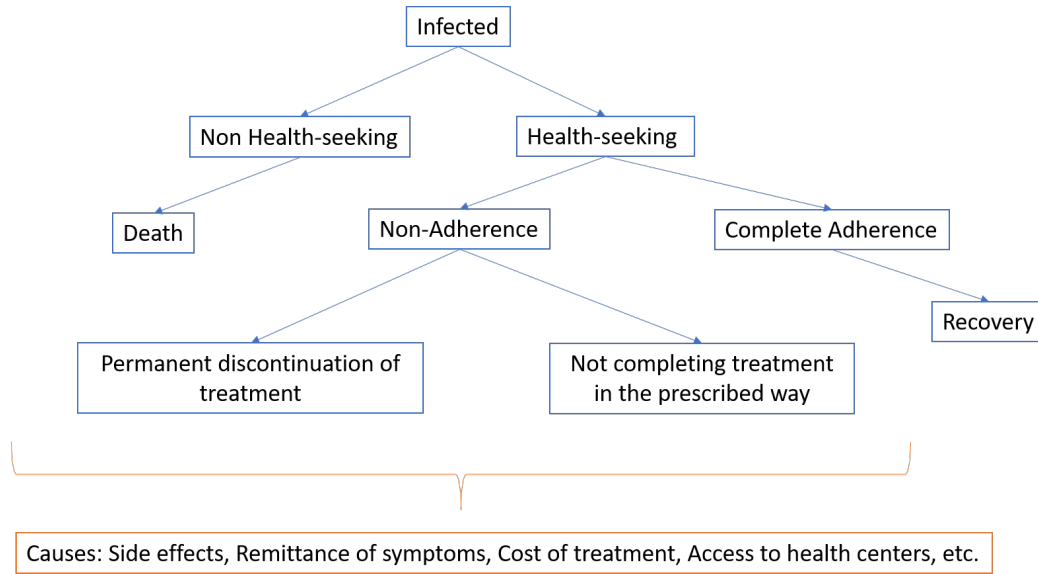

Figure 2.1: Flow of Treatment Access and Behaviors.

diseases, the adverse impact of treatment non-adherence on the disease spread, treatment efficacy and drug resistance has been studied for HIV and Tuberculosis. We intend on addressing the importance of treatment adherence in the control of VL by using data-driven and mechanistic approaches.

Treatment non-adherence for VL in Bihar : Bihar is one of the poorer states in India which is home to most VL cases of India. VL patients in Bihar do not strictly adhere to the treatment due to the fear of loss of wages and livelihood. Other causes of non-adherence in patients generally is cost of drugs, side-effects, “I am cured” syndrome in which patients stop the treatment upon remittance of symptoms, difficult access to the sparsely located health centers, health and disease illiteracy etc. (14; 15; 16). Kansal et. al. (2017) traced and interviewed defaulters in Muzaffarpur region to identify self-stated causes of non-adherence specific to the VL treatment (11). These causes are “Wanted to have second opinion”, “Preference for KA specialist”, due to other illness, Side effects of drug, Felt better after starting treatment,

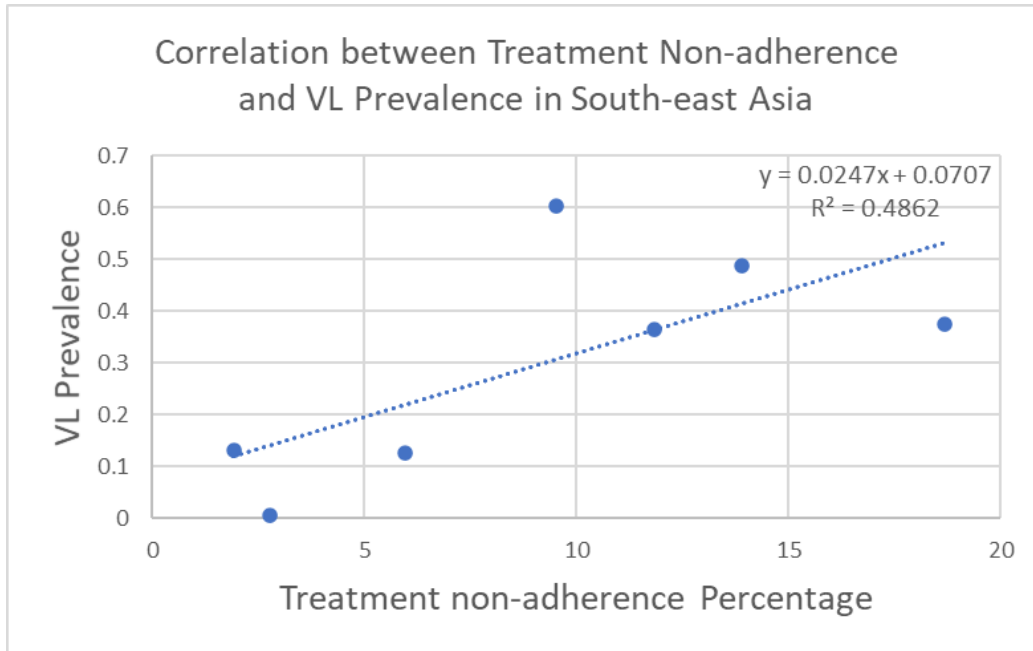

Figure 2.2: VL prevalence and treatment non-adherence percentage in different health facilities in India and Nepal based on the data from (19). For data a table with facility names, refer Table A.1.

Outstation duties during treatment, PHC is too far from home, Dissatisfied with the behaviour of PHC staff and treatment, Financial problem and Personal reasons (marriage, death, festival). According to a study (17), the main reported reasons for treatment interruption were lack of money for treatment (68.7%) and side effects (15.7%). For any treatment, adherence is crucial because non-adherence leads to morbidity, mortality, drug resistance etc. and results in loss in terms of health, money, facilities and overall quality of life (18; 12).

VL treatment non-adherence and its surveillance: Only around 30% VL patients access public health-care facilities. Since the current surveillance system mainly reports cases through public health centers, the VL cases are highly underreported (20) or face a big delay in getting reported (21). This also means that the treatment

non-adherence in private sectors is unreported. Furthermore, due to lack of thorough follow up of patients, treatment non-adherers are falsely reported as treated. This subpopulation of treatment non-adherers, depending on the treatment duration before defaulting, may be infectious thus serving as a hidden source of additional infections.

The differences between “underestimation”, “underreporting” and “underascertainment” are discussed by Gibbons et. al. (2014) (22). The underestimated infectious cases according to them, are a sum of the underreported cases (infectious cases diagnosed and seeking healthcare but not reported) and underascertained cases (all asymptomatic cases and all symptomatic cases that did not seek healthcare and therefore cannot be possibly reported through passive surveillance). In this chapter, we refer to underreporting as the difference between the actual number of infectious individuals and the number of health-seeking individuals assuming that all health-seeking get reported.

Goal of this paper As seen from Figure 2.2, higher treatment non-adherence appears to correspond to higher VL prevalence. However, the available data on VL treatment adherence in India is very scarce and thus conclusions on how the non-adherence and prevalence correlates cannot be made. The trends (type and intensity of nonlinear relationship) are also unclear. In a situation like this, mechanistic models are a great tool to gain insights on the problem.

There are various modeling studies on the role of non-adherence to the treatment for directly transmitted diseases like HIV (Human immunodeficiency virus), Soil-transmitted Helminthiasis, Tuberculosis, Leprosy etc. (details discussed in Section 2.2.2) and how it is detrimental to the reduction of disease prevalence and spread, however, there is no such study for VL, a vector-borne disease. Most of the existing

studies in literature are empirical (observational and interview) and we were unable to find any dynamical study, which typically uses mathematical models to specifically incorporate non-adherence. This work is the first study of its kind where we understand the impact of mechanisms related to patients' treatment behaviors on the transmission dynamics of VL via a data-driven mathematical model. We discuss the impact of different assumptions on non-adherence level, infectivity status of non-adherent individuals on the endemic prevalence, treatment access rate and suggest implications based on speeding up the reduction of VL cases from the South-east Asian region.

The specific research questions addressed are:

1. What is the critical proportion of treatment adherence needed to control VL via improved treatment implementation efforts in India?
2. How is improvement in treatment adherence related to the endemicity of VL in India under different treatment access rates?
3. What is the critical proportion of treatment non-adherence above which underreporting becomes crucial due to increased infection load by non-adherent patients?

2.2 Methods

2.2.1 *Previous VL Modeling Studies*

The first model-based study for anthroponotic VL was by Dye and Wolpart (1988) to identify mechanisms driving the outbreaks in Assam (23). The more contemporary and popular models are by Mubayi et. al. (2010) to estimate the underreporting of VL cases (24) and by Stauch et.al. (2012 and 2014) to understand the effect of vector

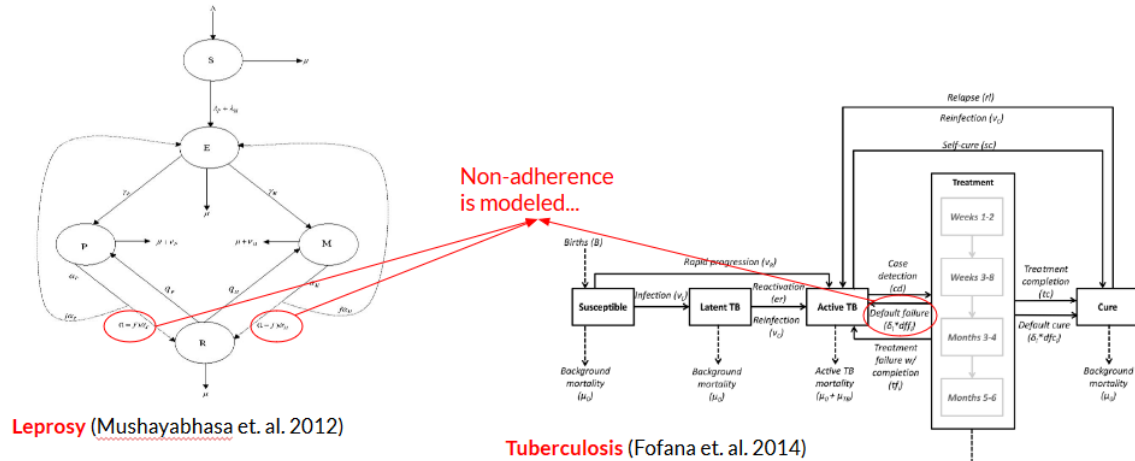

Figure 2.3: Examples of previous compartmental infectious disease transmission models which have incorporated treatment non-adherence. Sources of models: (28; 29).

control and PKDL cases on VL transmission (25; 26). Medley et. al. (2015) used VL dynamics model to show that early health-seeking can significantly reduce VL cases (27). In this chapter we will use a similar vector-host compartmental mathematical model to incorporate treatment non-adherence of patients under VL treatment.

2.2.2 Previous Mechanistic Treatment Non-Adherence Models

Patients' non-adherence to prescribed drug has been modeled using standard economic models for non-communicable diseases but not the effect of non-adherence on a population dynamics level (30). Mathematical modeling to capture the mechanism and effect of treatment non-adherence has been previously captured for to some extent for HIV (Human Immunodeficiency Virus), tuberculosis and leprosy due to their long treatment durations. These various studies have modeled drug concentration in an individual (31; 32; 33) within a host or population level dynamics to incorporate non-adherence as a fraction of people leaving treatment (34; 35; 36; 28; 37; 38). A couple examples are shown in Figure 2.3. Goals of these studies were to observe

the impact of relapse and treatment non-compliance on drug resistance and infection spread. Inspired from this literature and from the high potential for under-reporting and treatment non-adherence, in this study, we built a population level vector-host model for VL to explicitly capture patient class and their treatment behavior in terms of rate of treatment access, proportion of non-adherence and their contribution to infection spread before they recover. We have considered the infectivity due to the patients and have performed rigorous analysis on global stability of the system, unlike the previous studies.

2.2.3 Model Description

To capture the disease dynamics of Visceral Leishmaniasis, we use a compartmental vector-host model since VL is anthroponotic in India. The model is structured by dividing the human (host) population in *Susceptibles* (S_H), *Infected* (I_H), *Under treatment or patients* (T_H) and *Recovered* (R_H). Adult female sandfly (vector) population is divided into *Susceptible* (S_V) and *Infected* (I_V) compartments. Although the incubation time of the parasite in humans is about 4 weeks and in sandflies about 4-25 days (39), we have not considered a separate incubation or exposed class in both humans and vectors. Instead, we have incorporated this delay in the infection coefficients β_{HV} and β_{VH} of successful transmission of infection upon sandfly bite. Studies ((40; 41)) have analyzed the leishmaniasis transmission model with exposed classes for humans and vectors which will be useful in understanding the effect of VL control if the interventions are related to reducing vector bites. Treatment non-adhering patients are the focus for intervention in this project. In this study we assume that the infected people who undergo and complete the treatment as prescribed get recovered and get permanent immunity from getting infected again (42). The infected people who start the treatment but stop midway are said to be “non-adhering” people.

Note that the lifecycle of sandflies is highly dependent on the temperature and rainfall. If the temperature falls below 10 deg C in winter, the breeding is reduced due to diapause (43). Heavy rainfalls in monsoon may destroy the resting areas of developmental stages and affect flying activity thus affecting the maturity and reproduction of sandflies (44). However, in this work, we are assuming a constant rate related to vector biting and life cycle since the focus of this work is on the effect of human treatment behavior on VL over a time period (in years) which is significantly on a bigger scale than that of a sandfly's generation time. Therefore we assume that the seasonalities in vector-related parameters are negligible on the time-scale of interest.

Following set of ODEs describe the system represented by Figure 3.1:

$$\begin{aligned}
\frac{dS_H}{dt} &= \Lambda_H - b\beta_{VH}S_H\frac{I_V}{N_H} - \mu_H S_H \\
\frac{dI_H}{dt} &= b\beta_{VH}S_H\frac{I_V}{N_H} - \gamma I_H + \theta(1 - \phi)T_H - (\delta + \mu_H)I_H \\
\frac{dT_H}{dt} &= \gamma I_H - \theta T_H - \mu_H T_H \\
\frac{dR_H}{dt} &= \theta\phi T_H - \mu_H R_H \\
\frac{dS_V}{dt} &= \Lambda_V - b\beta_{HV}S_V\frac{I_H + \alpha T_H}{N_H} - \mu_V S_V \\
\frac{dI_V}{dt} &= b\beta_{HV}S_V\frac{I_H + \alpha T_H}{N_H} - \mu_V I_V
\end{aligned} \tag{2.1}$$

Apart from the dynamics of susceptible humans getting bit at rate b to get infected with a transmission rate β_{VH} (that is $1/\beta_{VH}I_V$ is the mean length of time an average susceptible human takes to become infected if it is exposed to I_V infective vectors), infected humans proceed to access treatment at a rate γ . The mechanisms of treatment non-adherence is similar to the model presented for Tuberculosis (29). A proportion ϕ of the people under treatment completely adhere to the treatment to get recovered at a rate θ . Due to high treatment efficacy of MIL in India, we assume

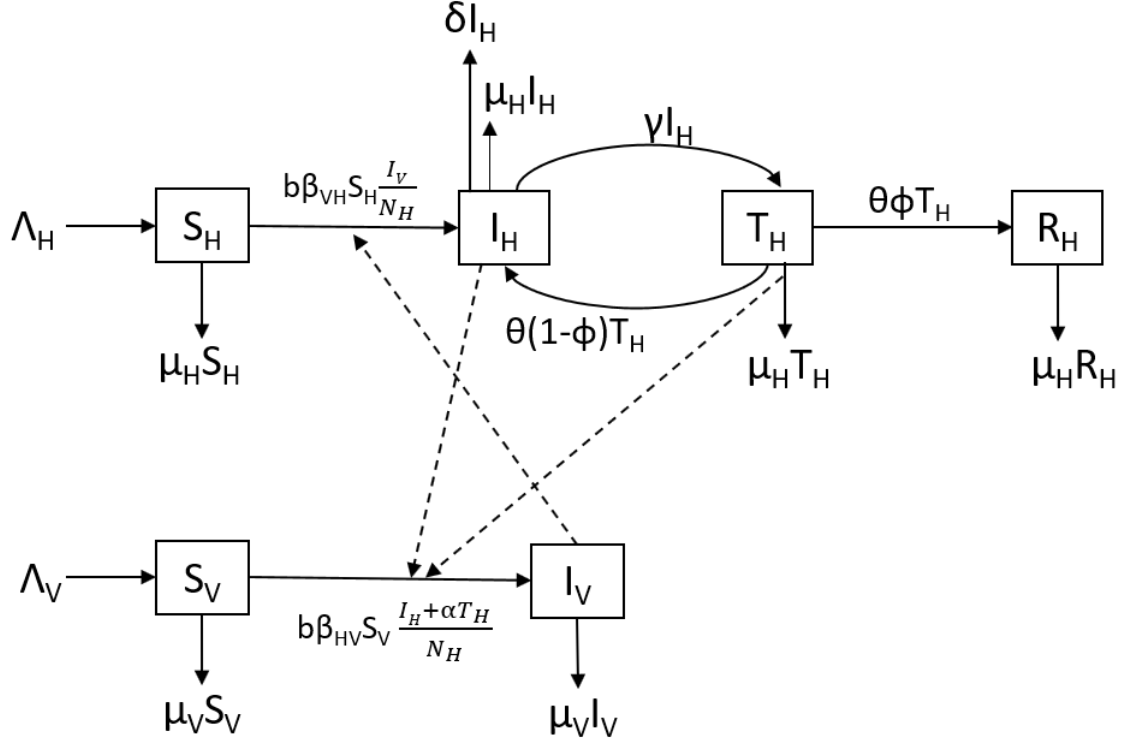

Figure 2.4: Flowchart of the vector-host model for VL dynamics. Here the compartments are *Susceptibles* (S), *Infected* (I), *Under treatment or patients* (T) and *Recovered* (R) where subscript H identifies host (humans) population and subscript V identifies vector population. Non-adherence to treatment for VL is captured by the expression $(1 - \phi)$ which is the proportion of people defaulting from the treatment.

that everyone who perfectly adheres is recovered. The rest $(1 - \phi)$ proportion of the patients move back to the infected compartment by defaulting from the treatment. Since T_H constitutes of patients getting treatment for the first time as well as defaulters who needed treatment again, on an average patients are capable of transmitting VL at reduced rate $\alpha\beta_{HV}T_H$ where $0 < \alpha < 1$. All humans are born susceptible to the disease and at a birth rate Λ_H ; natural per capita mortality rate is μ_H . Infected people can also die due to the disease at a rate δ per capita.

Sandflies' birth rate is Λ_V , and all newly recruited female adult sandflies are susceptible to the disease. Per capita mortality rate of vectors is μ_V . Susceptible sandflies can get infected by biting either infected humans or humans under treatment at a rate b to get infected at average transmission rates β_{HV} and $\alpha\beta_{HV}$ respectively.

2.2.4 Model-derived Novel Health Metrics

We analyze the dynamics of the disease and effect of non-adherence to the treatment independent of the effects of the ongoing vector control program. Furthermore, we compare the effect of treatment non-adherence on various new model-derived health-metrics as following:

- Total treatment non-adherence rate = $(1 - \phi)\theta$
- Treatment non-adherence as proportion = $(1 - \phi)$
- Total true prevalence (all infected compartments) = $I_H + T_H$
- Total reported prevalence (passive surveillance considers only people under treatment) = T_H

Note that, the difference between true and the reported prevalence constitute for the underreported cases due to treatment non-adherence.

- True incidence (total new infectious cases) = $b\beta_{VH}S_H I_V/N_H$

State variable	Definition
S_H	Number of humans susceptible to VL
I_H	Number of humans infected with VL
T_H	Number of individuals being treated for VL
R_H	Number of humans permanently recovered from VL
S_V	Density of sandflies in a unit area susceptible to VL
I_V	Density of sandflies in a unit area infected with VL

Table 2.1: Definitions of the State Variables in the Model 2.1

- Reported Incidence (passive surveillance considers only people starting the treatment) = γI_H
- Additional infectious cases due to treatment non-adherence = $\theta(1 - \phi)T_H$

In the first two definitions above, note that the treatment rate (θ) is understood in terms of the inverse of the total average duration of time spent in VL treatment by patients. Non-adherence proportion is usually the quantity measured through the observational or empirical field studies and hence the proportion ϕ is varied to measure the impact on outcomes so that the results are comparable with the literature. This implies that we assume that the distribution of non-adherence over time remains the same, but the change in outcome is due to the change in the proportion.

2.2.5

For numerical results based on the model, we obtained the estimates for model parameters as discussed in this section. In this model, we assume that the only treat-

Parameter	Definition
β_{HV}	Transmission rate of infection from humans to sandflies upon a susceptible vector biting an infected human
β_{VH}	Transmission rate of infection from sandflies to humans upon a susceptible human being bitten by an infected sandfly
μ_H	Per capita natural mortality rate of humans
μ_V	Per capita natural mortality rate of sandflies
δ	Per capita rate for diseased deaths in infected humans
b	Biting rate of sandflies per human
Λ_H	Natural birth rate of humans
Λ_V	Natural birth rate of sandflies
γ	Per capita rate of infected humans initiating treatment
θ	Per capita rate of humans leaving the treatment either due to recovery or non-adherence
ϕ	Proportion of humans leaving the treatment due to recovery
α	Ratio of infectivity of the patients with respect to the infectivity of the infected humans

Table 2.2: Definitions of the Parameters in the Model 2.1

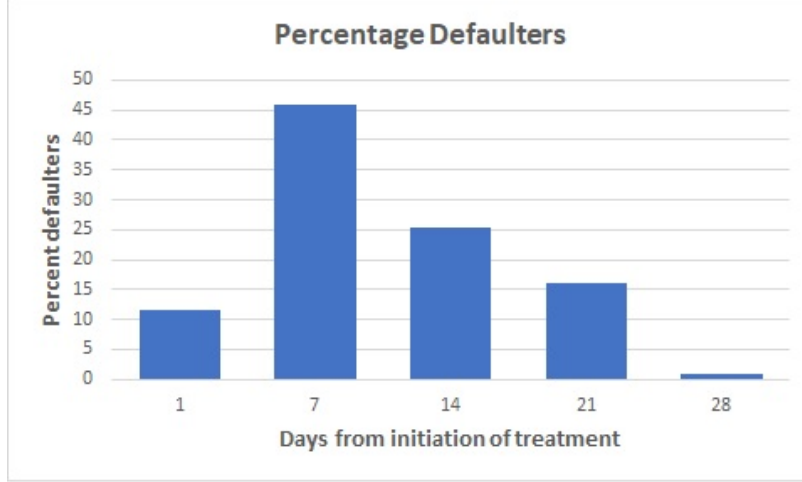

Figure 2.5: Observed number of defaulters (that is, non-adherence) to the treatment in Muzaffarpur district, Bihar, India where total number of patients initially was 542. Data obtained from (11).

ment administered is the 28-day MIL drug, the first-line treatment for VL in India. With the assumption that after every initiation of treatment it takes 28 days to completely recover from the disease, the rate of recovery $\theta\phi$ is $1/28 \text{ days}^{-1}$. The average proportion of people adhering to the treatment (ϕ) was calculated from the study by Kansal et. al. (2017) (11) . The authors record defaulters from December 2009 to June 2012 to show that 87 patients out of 542 cases completed the treatment (refer Figure 2.5 for histogram of number of defaulters per week) making the defaulters' percentage to be 16.3%.

Since the non-adherence is not uniform over the treatment regime, we find the value of treatment adherence (ϕ) using Pearson χ^2 goodness-of-fit statistic since the underlying distribution for data is unknown. From the original model (Equation 2.1), the treatment non-adherence rate is given by the part

$$\frac{dT_H}{dt} = \theta(1 - \phi)T_H$$

Therefore, using the relation that $\theta = (1/28)/\phi$ and the solution of the non-adherence rate:

$$T_H(t) = T_H(0)e^{-\theta(1-\phi)t}$$

where $T_H(0) = 542$ is fixed. We use Pearson's χ^2 method for goodness-of-fit since the data, even if ordinal, is binned with underlying distribution unknown. We assume that the data is homo-skedastic. Minimizing χ^2 statistic (Figure 2.7)

$$\chi^2 = \sum_i \frac{(\text{Observed}_i - \text{Expected}_i)^2}{\text{Expected}_i}$$

for parameter sweep for ϕ between 0 to 1 (biologically feasible range) by uniformly sampling 10,000 values yields the estimate of the parameter ϕ (proportion of treatment non-adherence).

2.3 Mathematical Analysis

In this section, we first show the model to be mathematically and biologically well-posed. Then, as shown in the flowchart in Figure 2.6, we prove existence and local stability of the disease-free equilibrium (DFE) using threshold reproduction number (R_c). We also prove the existence of backward bifurcation near $R_c = 1$ conditional on the treatment non-adherence proportion. The model is then reduced by assuming no disease-induced mortality rate (that is, $\delta = 0$) due to very few such reported VL cases for Bihar. For the reduced model, we show existence and local stability of one endemic equilibrium (EE) and a forward bifurcation at the threshold reproduction number of reduced system ($R_c(\delta = 0) = R_{c1} = 1$). For $R_{c1} < 1$, the DFE is globally asymptotically stable. We then further reduced the system to exhibit quasi-stationary state using singular perturbation theory since lifespan of humans longer than lifespan of sandflies ($\frac{1}{\mu_H} \gg \frac{1}{\mu_V}$). Furthermore, VL has been endemic in India, therefore we can reduce the model further to have dynamics similar to direct transmission

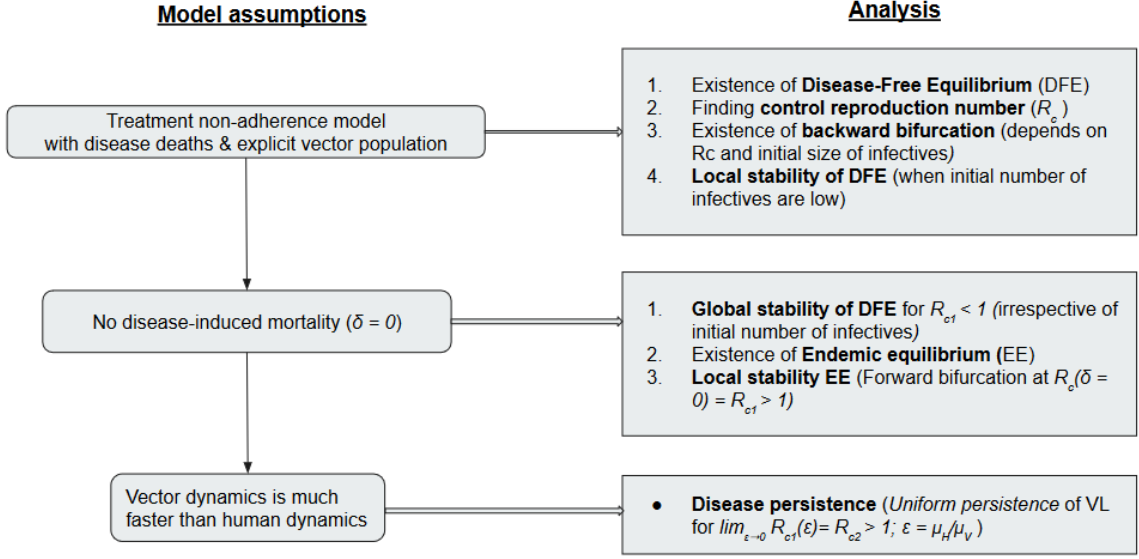

Figure 2.6: Flow of analysis of the model (Equation 2.1 done in this paper where R_c refers to the reproduction number calculated in Section 2.3.

(that is, Holling Type II interaction between S_H and I_H reduced to Holling Type I). Under the assumption $\mu_H \ll b\beta_{VH} \frac{N_V}{N_H}$, the vector-host model approximates the direct transmission model near the endemic equilibrium. Uniform persistence of VL is proved using this reduced model for reproduction number greater than 1.

Well-posedness and dissipativity: The system (2.1) is dissipative since the solutions are non-negative and uniformly eventually bounded (as defined in (45)) and it is biologically and mathematically well-posed. (Proof in Appendix B)

Disease-free equilibrium: The disease-free equilibrium (DFE) of the system 2.1 is calculated by setting the derivatives equal to zero with $I_H = 0$ and $I_V = 0$. Therefore the DFE $(\tilde{S}_H, \tilde{I}_H, \tilde{T}_H, \tilde{R}_H, \tilde{S}_V, \tilde{I}_V) = (\frac{\Lambda_H}{\mu_H}, 0, 0, 0, \frac{\Lambda_V}{\mu_V}, 0)$ asymptotically as shown in Appendix B.

Control reproduction number: While the basic reproduction number (R_0) quantifies the average secondary infections by primary cases, the control reproduction number (R_c) does so under a specified control which is treating infected humans in our case.

$$R_c^2(\alpha, (1 - \phi), \gamma, \delta) = \left(\frac{b\beta_{VH}(\frac{\alpha\gamma}{\theta + \mu_H} + 1)}{\delta + \mu_H + \gamma(1 - \frac{\theta(1-\phi)}{\theta + \mu_H})} \right) \left(\frac{b\beta_{HV}}{\mu_V} \right) \left(\frac{\Lambda_V/\mu_V}{\Lambda_H/\mu_H} \right) \quad (2.2)$$

This R_c is computed using the next-generation matrix method (46) as shown in Appendix B.

Local stability of the equilibria:

Theorem 1. *The DFE is locally asymptotically stable if $R_c^2 < 1$ and unstable if $R_c^2 > 1$.*

Proof in Appendix B.

Note that, in ideal cases, that is, perfect adherence ($(1 - \phi) = 0$), that is when patients complete the treatment as prescribed in the first time, and no infectivity by patients ($\alpha = 0$), the reproduction number R_c^2 here will be simply

$$\begin{aligned} \tilde{R}_c^2 = R_c^2(\alpha = 0, (1 - \phi) = 0) &= \left(\frac{b\beta_{VH}}{\delta + \mu_H + \gamma} \right) \left(\frac{b\beta_{HV}}{\mu_V} \right) \left(\frac{\Lambda_V/\mu_V}{\Lambda_H/\mu_H} \right) \\ &\leq R_c^2(\alpha, (1 - \phi)) \end{aligned} \quad (2.3)$$

This establishes that the disease can be controlled relatively easily in the ideal situations as described above, given that the initial prevalence is low enough.

Backward bifurcation:

Theorem 2. *The model (2.1) undergoes a backward bifurcation at $R_c = 1$ if per capita rate of mortality due to VL is sufficiently large.*

See proof in Appendix B.

Corollary 1. *The system undergoes backward bifurcation at $R_c = 1$ if the proportion of non-adherence $(1 - \phi)$ is large enough for $\delta > 0$. Specifically if*

$$(1 - \phi) > \frac{\theta + \mu_H}{2\mu_V\gamma\theta}((\mu_H + \gamma)(2\mu_V + b\beta_{HV}\mu_H N_V) - 2\mu_V\delta)$$

The source of this backward bifurcation may be solely the presence of diseased-deaths of infected humans at a rate δ as seen in other vector-borne disease models (47).

Endemic equilibrium: With the assumption $\delta = 0$, that is, the rate of humans dying of VL is comparatively lower than natural mortality rate (μ_H), the total human population is constant. The total vector population is also constant. That is, $N_H = \Lambda_H/\mu_H$ and $N_V = \Lambda_V/\mu_V$ are constant. Therefore the system can be reduced to four dimensions as follows

$$\begin{aligned}\frac{dS_H}{dt} &= \Lambda_H - b\beta_{VH}S_H\frac{I_V}{N_H} - \mu_H S_H \\ \frac{dI_H}{dt} &= b\beta_{VH}S_H\frac{I_V}{N_H} - \gamma I_H + \theta(1 - \phi)T_H - \mu_H I_H \\ \frac{dT_H}{dt} &= \gamma I_H - \theta T_H - \mu_H T_H \\ \frac{dI_V}{dt} &= b\beta_{HV}(N_V - I_V)\frac{I_H + \alpha T_H}{N_H} - \mu_V I_V\end{aligned}\tag{2.4}$$

such that $R_H = N_H - (S_H + I_H + T_H)$ and $S_V = N_V - I_V$.

The endemic equilibrium (EE) of this reduced system is

$$\begin{aligned}S_H^* &= \frac{N_H}{\frac{b^2\beta_{HV}\beta_{VH}I_H^*\Lambda_V\mu_H(\alpha\gamma + \theta + \mu_H)}{\Lambda_H\mu_V(b\beta_{HV}I_H^*\mu_H(\alpha\gamma + \theta + \mu_H) + \Lambda_H\mu_V(\theta + \mu_H))} + 1} \\ I_H^* &= \frac{\mu_V\Lambda_H N_H(\theta + \mu_H)(R_c^2 - 1)}{b\beta_{HV}(b\beta_{VH}N_V + \mu_H N_H)(\alpha\gamma + \theta + \mu_H)} \\ T_H^* &= \frac{\gamma}{\theta + \mu_H} I_H^* \\ I_V^* &= \frac{b\beta_{HV}N_V(1 + \frac{\alpha\gamma}{\theta + \mu_H})I_H^*}{\mu_V N_H + b\beta_{HV}(1 + \frac{\alpha\gamma}{\theta + \mu_H})I_H^*}\end{aligned}\tag{2.5}$$

and the control reproduction number for this reduced system is

$$R_c^2(\delta = 0) = R_{c1}^2 = \left(\frac{b\beta_{VH}(\frac{\alpha\gamma}{\theta+\mu_H} + 1)}{\delta + \mu_H + \gamma(1 - \frac{\theta(1-\phi)}{\theta+\mu_H})} \right) \left(\frac{b\beta_{HV}}{\mu_V} \right) \left(\frac{N_V}{N_H} \right) \quad (2.6)$$

Note that the EE exists only if $R_{c1}^2 > 1$.

Global stability of DFE

Theorem 3. *If $\delta = 0$ and $R_c < 1$, then the DFE for the model 2.4 is globally asymptotically stable in the positively invariant space*

$$\Omega = \{(S_H(t), I_H(t), T_H(t), R_H(t), S_V(t), I_V(t)) \mid \\ 0 \leq S_H(t) + I_H(t) + T_H(t) + R_H(t) = N_H, 0 \leq S_V(t) + I_V(t) = N_V \forall t > 0\}.$$

Proof in Appendix B.

Singular perturbations: The time scale of vector dynamics is relatively fast as compared to the host dynamics since the lifespan of humans is very large compared to sandflies' (i.e. $1/\mu_H \gg 1/\mu_V$). Let a small quantity $\epsilon > 0$ be defined as $\epsilon = \frac{\mu_H}{\mu_V}$. With the substitution $\mu_V = \mu_H/\epsilon$, the differential equation for I_V becomes

$$\epsilon \frac{dI_V}{dt} = b\epsilon\beta_{HV}(N_V - I_V)\frac{I_H}{N_H} - \mu_H I_V$$

with $\alpha = 0$ that is the patients are infecting. This assumption holds if patients follow a behavior such that they are not exposed to sandflies.

As $\epsilon \rightarrow 0$, if $\epsilon\beta_{HV} \rightarrow \beta^* > 0$ then, the system 2.4 can further be reduced to three dimensions with the assumption of quasi-stationary state of $I_V(t, \epsilon) \rightarrow I_V^*$. That is, since the time scale of vector dynamics is relatively fast as compared to the host dynamics, we assume that the vector population reaches steady state quickly.

Therefore, the reduced model is as follows

$$\begin{aligned}
\frac{dS_H}{dt} &= \Lambda_H - b\beta_{VH}S_H\frac{I_V^*}{N_H} - \mu_H S_H \\
\frac{dI_H}{dt} &= b\beta_{VH}S_H\frac{I_V^*}{N_H} - \gamma I_H + \theta(1 - \phi)T_H - \mu_H I_H \\
\frac{dT_H}{dt} &= \gamma I_H - \theta T_H - \mu_H T_H
\end{aligned} \tag{2.7}$$

where,

$$I_V^* = \frac{b\beta_{HV}N_V I_H}{b\beta_{HV}I_H + \mu_H N_H}$$

Using Levinson-Tikhonov theorem, as $\epsilon \rightarrow 0$, the solution of the reduced system is a good approximation for that of the original system in the interval $0 < d \leq t < \infty$ for some d . Furthermore, using Hoppensteadt theorem, the solution of the reduced system converges uniformly to that of the original system as $\epsilon \rightarrow 0$ in closed subsets of time interval $0 < t < \infty$ (48). Therefore, this reduced system can be used as a good approximation for the previous version of the model except near $t = 0$.

The control reproduction of this special case is

$$R_{c2}^2 = \lim_{\epsilon \rightarrow 0} R_{c1}(\epsilon, \alpha = 0) = \left(\frac{b\beta_{VH}}{\mu_H + \gamma(1 - \frac{\theta(1-\phi)}{\theta + \mu_H})} \right) \left(\frac{b\beta^*}{\mu_H} \right) \left(\frac{N_V}{N_H} \right) \tag{2.8}$$

Uniform persistence of EE: The quasi-stationary state assumption made in system 2.7 represents the transmission term to be of the form Holling Type II interaction. The assumption $\mu_H \ll b\beta_{VH}\frac{N_V}{N_H}$ (that is, disease transmission from vector to human is faster than mortality) allows the vector-host system to have dynamics like that of a direct transmission model near the EE (49; 50). Since, we want to study conditions for persistence of VL, we reduce the model derived from 2.7 to now look

like (with Holling Type I interaction for disease transmission):

$$\begin{aligned}
N_H &= S_H + I_H + T_H + R_H \\
S'_H &= \Lambda_H - \beta S_H \frac{I_H}{N_H} - \mu_H \\
I'_H &= \beta S_H \frac{I_H}{N_H} - (\mu_H + \gamma)I_H + \theta(1 - \phi)T_H \\
T'_H &= \gamma I_H - (\theta + \mu_H)T_H
\end{aligned} \tag{2.9}$$

where $\beta = \frac{b^2\beta_{VH}\beta^*}{\mu_H}$. The reproduction number can be rewritten as a function of β as

$$\tilde{R}_c^2 = \left(\frac{b\beta_{VH}}{\mu_H + \gamma(1 - \frac{\theta(1-\phi)}{\theta+\mu_H})} \right) \left(\frac{\beta}{\mu_H} \right) \left(\frac{N_V}{N_H} \right).$$

We now introduce a new variable Z_H as follows

$$Z_H = kI_H + T_H$$

. Taking the time derivative

$$\begin{aligned}
Z'_H &= kI'_H + T'_H \\
&= k(\beta S_H \frac{I_H}{N_H} - (\mu_H + \gamma)I_H + \theta(1 - \phi)T_H) + (\gamma I_H - (\theta + \mu_H)T_H) \\
&= k\beta S_H \frac{I_H}{N_H} - k(\gamma + \mu_H)I_H + \gamma T_H + (k\theta(1 - \phi) - (\theta + \mu_H))T_H
\end{aligned}$$

Setting $k = \frac{\theta + \mu_H}{\theta(1 - \phi)}$, Z'_H does not depend on T_H and $T_H = Z_H - \frac{\theta + \mu_H}{\theta(1 - \phi)}I_H$. Using these substitutions, the system now becomes

$$\begin{aligned}
N_H &= S_H - \frac{\theta\phi + \mu_H}{\theta(1 - \phi)}I_H + Z_H + R_H \\
S'_H &= \Lambda_H - \beta S_H \frac{I_H}{N_H} - \mu_H \\
I'_H &= \beta S_H \frac{I_H}{N_H} - (\mu_H + \gamma)I_H + \theta(1 - \phi)(Z_H - \frac{\theta + \mu_H}{\theta(1 - \phi)}I_H) \\
Z'_H &= \beta \frac{\theta + \mu_H}{\theta(1 - \phi)}I_H \left(\frac{S_H}{N_H} - \frac{1}{\tilde{R}_c^2} \right) \\
R'_H &= \theta\phi Z_H - \frac{\phi}{1 - \phi}(\theta + \mu_H)I_H - \mu_H R_H
\end{aligned} \tag{2.10}$$

Notice that

$$0 \leq I_H + T_H \leq Z_H \leq N_H \left(1 + \frac{\theta\phi + \mu_H}{\theta + \mu_H}\right)$$

because S_H , I_H , T_H and R_H are non-negative and add up to N_H .

Note the meaning of the following notations used in this paper

$$y^\infty = \limsup_{t \rightarrow \infty} y(t)$$

$$y_\infty = \liminf_{t \rightarrow \infty} y(t)$$

Theorem 4. *Let $\tilde{R}_c^2 > 1$. If $Z_H(0) > 0$, $Z_H(t)$ does not converge to zero as $t \rightarrow \infty$ and $S_{H\infty} \leq \frac{N_H}{\tilde{R}_c^2}$.*

Proof in Appendix B

Corollary 2. *If $\tilde{R}_c > 1$ and $I_H(0) > 0$ then $I_H(t)$ does not converge to zero as $t \rightarrow \infty$. If $S_H(t)$, $I_H(t)$ and $T_H(t)$ are bounded then the system is uniformly persistent as $t \rightarrow \infty$ for all initial conditions with $I_H > 0$ and hence, EE is globally asymptotically stable.*

2.4 Results

2.4.1 Parameter Estimates

Estimating treatment adherence parameter: The estimate of the proportion of treatment non-adherence upon minimizing the Pearson's χ^2 statistic comes out to be $\phi = 0.82 \pm 0.07$ (Pearson $\chi^2 = 2.342$, df = 4, p = 0.22) for statistical significance level 0.95 (Figure 2.8). Therefore, current value of θ is 0.044 day^{-1} .

Point estimates of model parameters from literature: The total human population is assumed to be around 4.8 million which was taken from the 2011 census for the district of Muzaffarpur in Bihar, India (51). The number of sandflies present

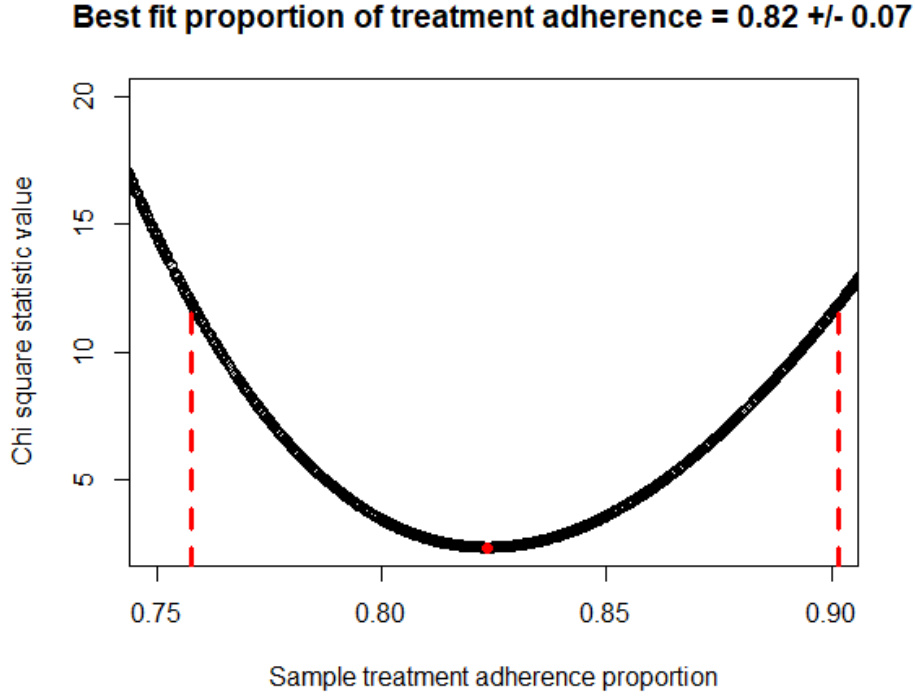

Figure 2.7: Minimizing χ^2 statistic for parameter sweep for ϕ between 0 to 1 (biologically feasible range) by uniformly sampling 10,000 times. The best fit estimate is 0.82 ± 0.07 (95% confidence interval) as shown in the plot. Equation: $T_H(t) = T_H(0)e^{-\theta(1-\phi)t}$ where t is x-axis and $T_H(t)$ is y-axis. $\chi^2 = 2.342$

was taken to be 0.75 times the human population following the conversion by Biswas (2017) (52). In the study by Medley et. al. (2015), the average duration from initiation of symptoms to diagnosis was quantified for Bihar to be 98 days. Assuming that the people start treatment immediately after diagnosis, the rate of health-care access γ is calculated to be $1/98 \text{ day}^{-1}$ (27). As per our knowledge, the infectivity of people under treatment relative to the newly infected humans has not been quantified and hence α is varied between 0 through 1. All other estimates as shown in Table 3.3.3 are taken from the estimates used by ELmojtaba et.al. (2010) (53).

Parameter	Point estimate [Range]	Source
Λ_H	$0.0015875 \times N_H \text{ day}^{-1}$	(53)
Λ_V	$0.299 \times N_V \text{ day}^{-1}$	(53)
N_H	4.8×10^6	(51)
N_V	$0.75 N_H$	(52)
b	0.2856 day^{-1}	(53)
γ	0.0102 day^{-1}	(27)
β_{HV}	0.22 day^{-1}	(53)
β_{VH}	0.0714 day^{-1}	(53)
θ	0.044 day^{-1}	Computed using (54) and (11)
μ_H	0.00004 day^{-1}	(53)
μ_V	0.189 day^{-1}	(53)
ϕ	$0.82 [0,1]$	Computed using data from(11)
δ	$1/730 \text{ day}^{-1}$	(55)
α	$[0, 1]$	-

Table 2.3: Parameter estimates for the model. See Section 2.4.1 for details.

Best fit curve with proportion of treatment adherence = 0.82

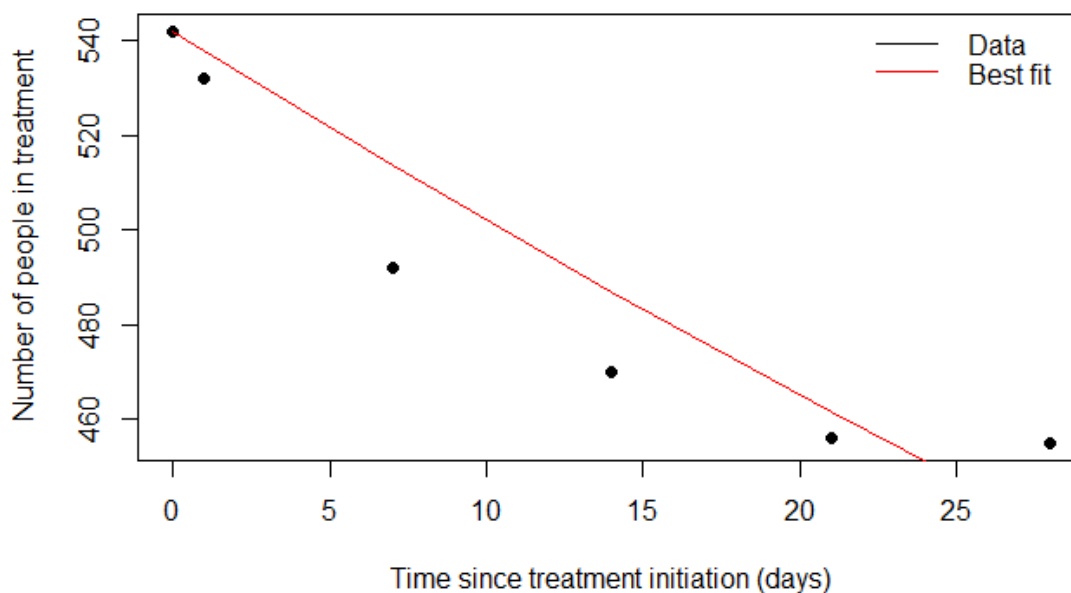

Figure 2.8: Expected number of people in treatment using best fit treatment adherence proportion (ϕ) as 0.82 overlaid on the observed data.

2.4.2 Results from mathematical analysis

From Equation 2.3, it can be seen that the disease can be controlled relatively easily in the ideal situations (i.e. patients not infectious and perfect treatment adherence), given that the initial prevalence is low enough. Although, when the disease-induced mortality rate (δ) is positive, *we can find the critical proportion of treatment non-adherence ($1 - \phi$) for which the system undergoes backward bifurcation.* That is, if treatment non-adherence is greater than the critical, even if the reproduction number is less than 1, the system might attain endemic equilibrium depending on the initial prevalence.

As treatment non-adherence increases, the rate of health-care access should also increase rapidly to be able to control the disease (i.e. attain $R_c < 1$). However, *when relative rate of infection spread due to patients is high enough, as treatment non-adherence increases, one might get in a situation where no amount of health-care access rate will ensure the feasibility of VL control* (Figure 2.9).

When the disease-induced mortality is negligible, we can find a critical treatment non-adherence (when $R_c < 1$) below which VL can be controlled irrespective of initial prevalence. If $R_c > 1$ the system will reach endemic state if the initial prevalence is high enough.

Under the assumptions $\mu_H/\mu_V \ll 1$ and $\mu_H \ll b\beta_{VH}N_V/N_H$, that is when the natural mortality rate of humans is significantly lower than that of the vectors and is lower than the total infection transmission rate of VL from sandflies to adults, then even if the initial prevalence is very low, VL will persist. However, we will not know precisely at what level.

It is apparent that the total VL prevalence can be estimated from the model as $I_H + T_H$. However, based on the current surveillance for VL cases in Bihar, the reported prevalence is quantified as the people who get diagnosed and are being treated for VL, corresponding to T_H class from the model. As treatment non-adherence increases, the discrepancy in the reported and the true endemic prevalences (as estimated from the model) increases in a certain range. The effect of increasing treatment non-adherence is stronger on reported cases as compared to that on true cases (Figure 2.10). Notice that, *the effect of varying treatment adherence is not linear* unlike as hypothesized from Figure 2.2.

The true VL incidence can be estimated from the model to be $b\beta_{VH}S_H \frac{I_V}{N_H}$ rate. The incidence reported is the new cases initiating the treatment corresponding to γI_H rate in the model. The true incidence is higher than reported for low treatment non-

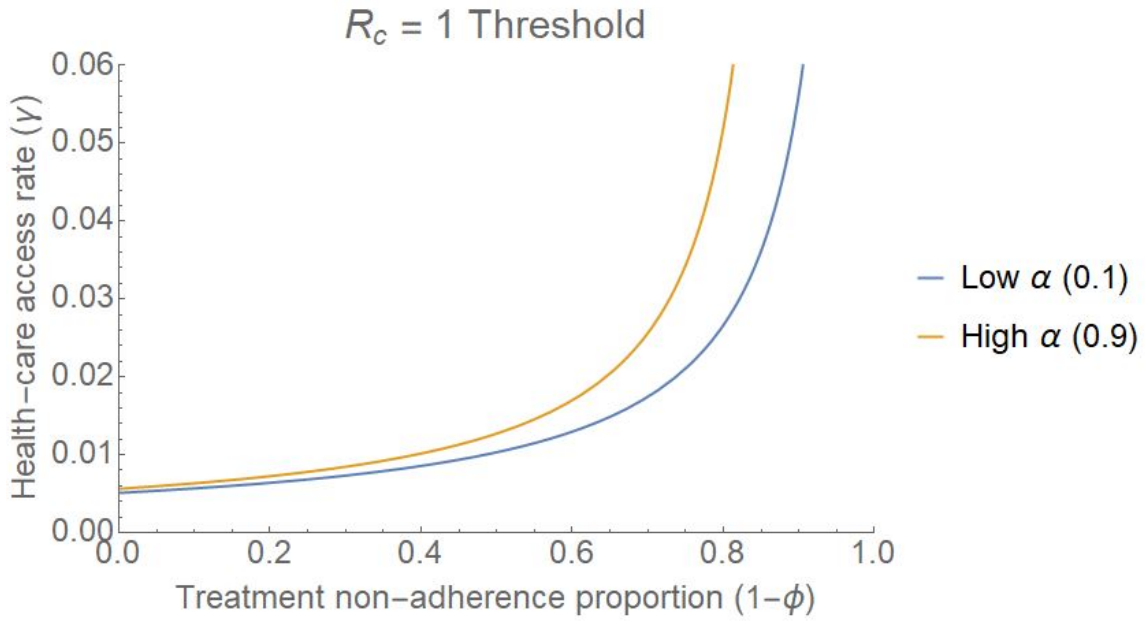

Figure 2.9: Reproduction number threshold curve ($R_c = 1$). Regions under the curves represent $R_c > 1$, and regions over the curves represent $R_c < 1$.

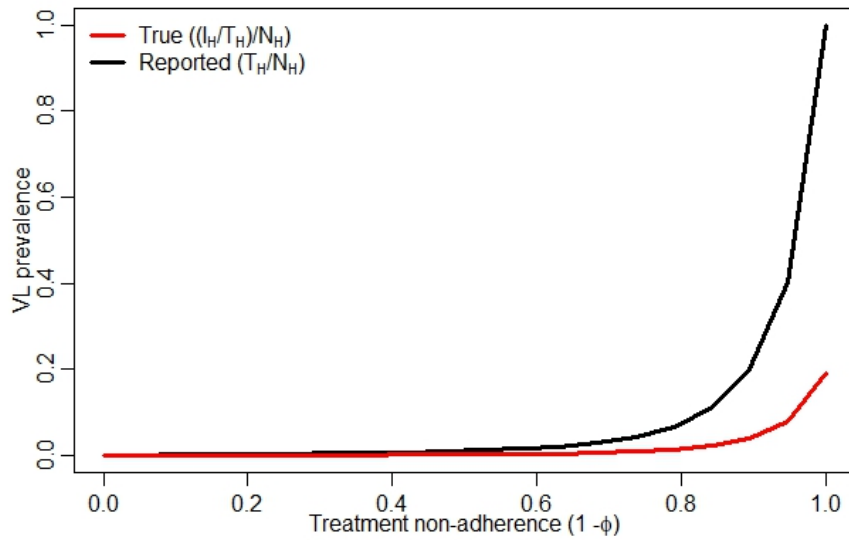

Figure 2.10: Discrepancy of the effect of varying treatment non-adherence on the reported and the true endemic prevalences (as estimated from the model).

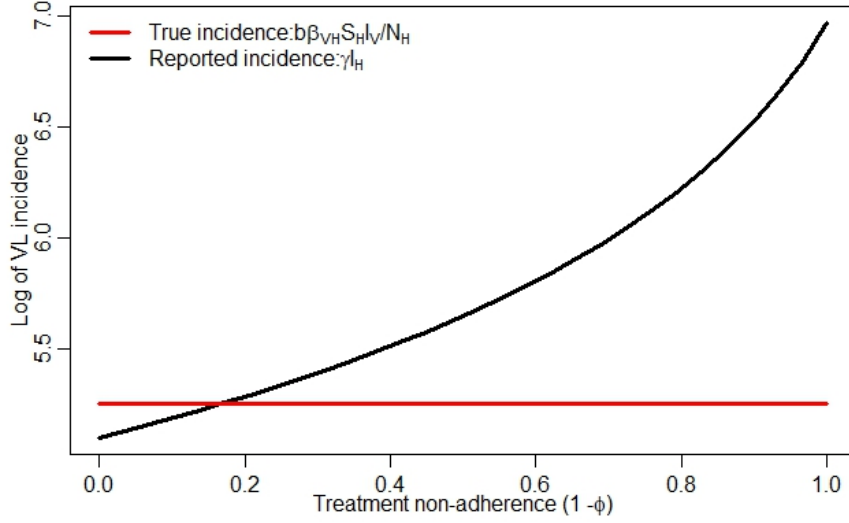

Figure 2.11: Effect of increasing treatment non-adherence ($1 - \phi$) on the true ($b\beta_{VH}S_H\frac{I_V}{N_H}$) and reported (γI_H) incidence metrics from the model in endemic state.

adherence. As treatment non-adherence increases, the reported incidence at endemic state increases rapidly as compared to the increase in true incidence (Figure 2.11).

The total rate of non-adherence ($\theta(1 - \phi)T_H$) represents the additional infectious cases arising due to the defaulters. This quantity is seldom reported. Figure 2.12 shows that increasing treatment non-adherence leads to increased additional VL case load. Furthermore, when the treatment non-adherence is high, the rate of health-care access (γ) needs to be considered to quantify this additional load correctly.

Additionally, we also found conditions for which (1) vector population attains quasi-stationary state ($\lim_{\epsilon \rightarrow 0} \epsilon\beta_{HV} = \beta^* > 0$ for $\epsilon = \mu_H/\mu_V$); (2) the endemic state of the vector-host system can be estimated from direct transmission type model ($\mu_H \ll b\beta_{VH}N_V/N_H$). It was shown that *in the case of negligible disease-induced mortalities, reproduction number being less than 1 is a crucial threshold to control VL even when prevalence is low.*

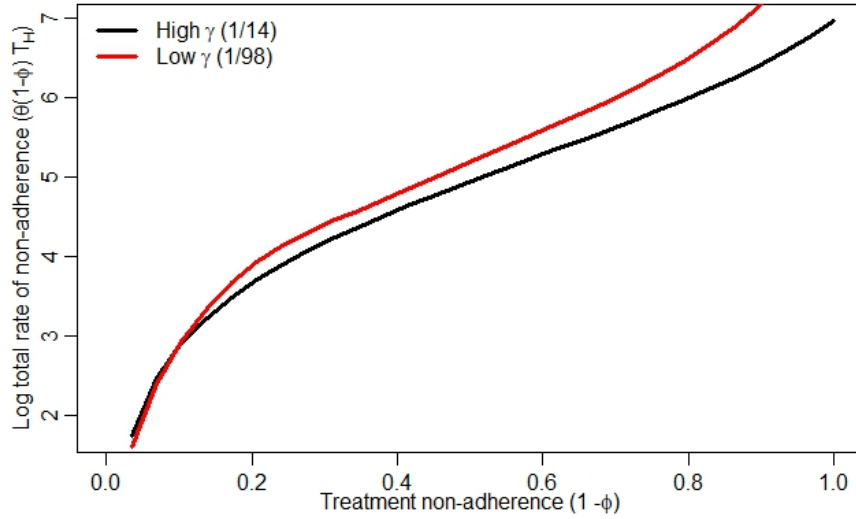

Figure 2.12: Effect of treatment non-adherence on the additional infectious cases per day arising due to the defaulters $(\theta(1 - \phi)T_H)$ for different health-care access rates (γ).

2.5 Discussion

Even though Visceral Leishmaniasis is fatal in 95% of the cases if untreated, treatment adherence is relatively low in Bihar, India as also is its reporting. Mathematical models for tuberculosis and leprosy have studied population level dynamics to incorporate non-adherence as a fraction of people leaving treatment (34; 35; 36; 28; 38). Inspired from this literature and from the high potential for under-reporting and treatment non-adherence, in this study, we built a population level vector-host model for VL to explicitly capture patient class and their treatment behavior in terms of rate of treatment access, non-adherence and their contribution to infection spread before they recover. We have considered the infectivity due to the patients and have performed rigorous analysis on global stability of the system, unlike the previous studies. We could find the conditions for which the effect of treatment non-adherence on en-

demic state of vector-host disease would approximate its effect on directly transmitted disease.

We estimated that from the data from (11) for Bihar, the average treatment adherence was 82% which is close to that in Nepal (83%) as shown by (12). The data used was a one time weekly measurement of 542 people who started the treatment. Daily measurement would help the parameter estimation be better informed and more explorations can be done in terms of the distribution of treatment non-adherence.

From the model developed in this study, we could see that if the proportion of non-adherence to treatment gets very small, backward bifurcation can occur. That is, when treatment adherence is improved actively to reduce disease spread and failure of treatment, one should be careful about the prevalence level; the prevalence should be made low enough through other interventions to prevent the disease from stabilizing at the endemic level.

We showed that in the ideal situation of perfect adherence and patients being non-infectious, controlling the disease would be easier. Since the treatment adherence was seen to be different from city to city (Figure 2.2), the heterogeneity in the reproduction numbers in spatial context can also be measured using the model. However, due to the high dimension of the model, extending it to include spatial heterogeneity will increase the complexity. We proved successful reduction of model from 6-D to 3-D upon specific assumptions as shown in previous section to increase model's scope of future extensions. However, quantifying the total rate of perfect treatment adherence (in presence of some treatment non-adherence) is not possible through the model since the patients class consists of both first-time treatment seekers and treatment non-adherers reinitiating the treatment.

We know that the half-life of MIL is about 7 days (56), but the average infectivity of the patients based on their MIL concentration has not been quantified. Due to

extremely low perfect treatment adherence (53% in Nepal (12)), patients' infectivity plays an important role in the VL dynamics (Figure 2.9). Although the study assumes homogeneous mixing of host and vector population, and considers MIL monotherapy for all, it lays a framework for capturing the effect of treatment non-adherence for VL and treatment behavior. The model can be easily extended to further consider the effect of treatment non-adherence resulting from various different causes (monsoons affecting treatment access, different effects of mild and severe drug side-effects, disease awareness, etc.) and can be used in region-specific studies. Refer to Appendix C for some sample potential extensions.

Medley et. al. (2015) showed that instead of providing diagnostic tests for VL to the patients suffering from fever for more than 2 weeks, it would be better if the rate of health-care seeking was higher (27). They also quantified the average time from symptoms to treatment initiation to be 98 days in Bihar, which is excessive. Upon assessment of the effect of treatment access-rate in combination with treatment non-adherence (Figure 2.12), we can see that the impact of increasing access rate is important when the treatment non-adherence is high.

In Bihar, VL cases get reported when infected people access some public hospital (public health center) for diagnosis. From the model, we could identify the reported incidence as the flow of infected people into treatment class (at a rate γI_H). But, the true incidence of VL is the rate at which people are newly infected ($b\beta_{VH}S_H I_V/N_H$ from the model). It was seen that reported incidence increases faster in comparison with true incidence as treatment non-adherence increased (Figure 2.11). This is due to the increased number of people in infected class due to non-adherence and hence the total access rate keeps growing as less people complete the treatment as prescribed. As treatment non-adherence increases, the total prevalence (infected people as well as patients) increases rapidly even if it cannot be seen from the reported prevalence,

which counts only patients (Figure 2.10). This shows that a thorough follow-up of patients with record-keeping and improving treatment adherence is critical for reliable reporting outcomes.

The model developed in this paper studies VL dynamics with only treatment as control. However, to control and hopefully eliminate VL from Bihar WHO in collaboration with the Indian government has been implementing sophisticated vector management programs. The combined effect of implementing vector control and improving treatment adherence can be studied by extension of the model. We also assumed that all patients (treated for 1 day vs. for 27 days) exhibit a similar average treatment non-adherence behavior as well as infectivity which may not be realistic. To correct for this, the treatment class can be split up into multiple classes based on their different attributes (as done in (35) for tuberculosis). In spite of these limitations, we believe that this paper gives readers an insight on the average impact of treatment behaviors on VL dynamics and encourages more informed data collection to obtain specific policy guidance through it.

Treatment is effective only if people take it, and development of new treatments is an expensive and time-taking process. Treatment non-adherence is an important aspect in VL spread, specially due to the length of MIL monotherapy (which is the most common treatment recommendation in Bihar) and inadequate surveillance. To get closer to the elimination target in Bihar, along with the on-going control strategies, improvement in treatment adherence should be also actively monitored and corrected for. In the future studies, we plan to consider defaulters separately from the new infectious cases since the treatment behavior as well as infectivity is different for them due to some exposure to the drug. This would result in capability to study the differences in effect of patient behavior in different phases of their treatment.

REFERENCES

- [1] World Health Organization: Media, “Leishmaniasis,” April 2017. <http://www.who.int/mediacentre/factsheets/fs375/en/>.
- [2] D. Bora, “Epidemiology of visceral leishmaniasis in india,” *National Medical Journal of India*, vol. 12, pp. 62–68, 1999.
- [3] D. L. Sacks, “Leishmania–sand fly interactions controlling species-specific vector competence: Microreview,” *Cellular microbiology*, vol. 3, no. 4, pp. 189–196, 2001.
- [4] F. Chappuis, S. Sundar, A. Hailu, H. Ghalib, S. Rijal, R. W. Peeling, J. Alvar, and M. Boelaert, “Visceral leishmaniasis: what are the needs for diagnosis, treatment and control?,” *Nature reviews microbiology*, vol. 5, no. 11, pp. 873–882, 2007.
- [5] T. Ilg, Y.-D. Stierhof, M. Wiese, M. McConville, and P. Overath, “Characterization of phosphoglycan-containing secretory products of leishmania,” *Parasitology*, vol. 108, no. S1, pp. S63–S71, 1994.
- [6] R. Lodge and A. Descoteaux, “Leishmania invasion and phagosome biogenesis,” in *Molecular Mechanisms of Parasite Invasion*, pp. 174–181, Springer, 2008.
- [7] R. Pulvertaft and G. Hoyle, “Stages in the life-cycle of leishmania donovani,” *Transactions of the Royal Society of Tropical Medicine and Hygiene*, vol. 54, no. 2, pp. 191–196, 1960.
- [8] S. Sundar, D. Mondal, S. Rijal, S. Bhattacharya, H. Ghalib, A. Kroeger, M. Boelaert, P. Desjeux, H. Richter-Airijoki, and G. Harms, “Implementation research to support the initiative on the elimination of kala azar from bangladesh, in-

dia and nepal—the challenges for diagnosis and treatment,” *Tropical Medicine & International Health*, vol. 13, no. 1, pp. 2–5, 2008.

- [9] S. Sundar, A. Singh, M. Rai, V. K. Prajapati, A. K. Singh, B. Ostyn, M. Boelaert, J.-C. Dujardin, and J. Chakravarty, “Efficacy of miltefosine in the treatment of visceral leishmaniasis in india after a decade of use,” *Clinical infectious diseases*, vol. 55, no. 4, pp. 543–550, 2012.
- [10] Hugtenburg J. G., Timmers L., Elders P. J. M., Vervloet M., van Dijk L., “Definitions, variants, and causes of nonadherence with medication: a challenge for tailored interventions,” *Patient Preference and Adherence*, vol. 7, pp. 675–682, 2013.
- [11] Kansal, S., Chakravarty, J., Kumar, A., Malaviya, P., Boelaert, M., Hasker, E., Ostyn, B., Sundar, S., “Risk Factors associated with defaulting from visceral leishmaniasis treatment: analysis under routine programme conditions in Bihar, India,” *Tropical Medicine & International Health*, vol. 22, no. 8, pp. 1037–1042, 2017.
- [12] Uranw S., Ostyn B., Dorlo T. P.C., Hasker E., Dujardin B., Dujardin J. C., Rijal S., Boelaert M., “Adherence to miltefosine treatment for visceral leishmaniasis under routine conditions in Nepal,” *Trop Med Int Health*, vol. 18, pp. 179–187, 2013.
- [13] E. Sabaté, E. Sabaté, *et al.*, *Adherence to long-term therapies: evidence for action*. World Health Organization, 2003.
- [14] Tedla Y. G. and Bautista L. E., “Drug Side Effect Symptoms and Adherence to Antihypertensive Medication,” 2015.

- [15] Bosworth H. B., “Enhancing medication adherence: The public health dilemma,” 2014.
- [16] Torrey T., “Reasons patients don’t comply with treatment recommendations,”
- [17] Mondal D., Singh S. P., Kumar N., Joshi A., Sundar S., Das P., Siddhivinayak H., Kroeger A., Boelaert M., “Visceral Leishmaniasis Elimination Programme in India, Bangladesh, and Nepal: Reshaping the Case Finding/Case Management Strategy,” *PLOS Neglected Tropical Diseases*, vol. 3, no. 1, pp. 1–8, 2009.
- [18] Lee H. J., Jang S. I., Park E. C., “Effect of adherence to antihypertensive medication on stroke incidence in patients with hypertension: a population-based retrospective cohort study,” *BMJ Open*, vol. 7, 2017.
- [19] Ostyn B., Hasker E., Dorlo T. P. C., Rijal S., Sundar S., Dujardin J.-C., Boelaert M., “Failure of Miltefosine Treatment for Visceral Leishmaniasis in Children and Men in South-East Asia,” *PLOS ONE*, vol. 9, pp. 1–8, 06 2014.
- [20] M. A. M. A. DebRoy S., Prosper O., “Challenges in modeling complexity of neglected tropical diseases: a review of dynamics of visceral leishmaniasis in resource limited settings,”
- [21] J. P. Boettcher, Y. Siwakoti, A. Milojkovic, N. A. Siddiqui, C. K. Gurung, S. Rijal, P. Das, A. Kroeger, and M. R. Banjara, “Visceral leishmaniasis diagnosis and reporting delays as an obstacle to timely response actions in nepal and india,” *BMC infectious diseases*, vol. 15, no. 1, p. 43, 2015.
- [22] C. L. Gibbons, M.-J. J. Mangen, D. Plass, A. H. Havelaar, R. J. Brooke, P. Kramarz, K. L. Peterson, A. L. Stuurman, A. Cassini, E. M. Fèvre, *et al.*, “Mea-

suring underreporting and under-ascertainment in infectious disease datasets: a comparison of methods,” *BMC public health*, vol. 14, no. 1, p. 147, 2014.

- [23] C. Dye and D. M. Wolpert, “Earthquakes, influenza and cycles of indian kala-azar,” *Transactions of the Royal Society of Tropical Medicine and Hygiene*, vol. 82, no. 6, pp. 843–850, 1988.
- [24] A. Mubayi, C. Castillo-Chavez, G. Chowell, C. Kribs-Zaleta, N. A. Siddiqui, N. Kumar, and P. Das, “Transmission dynamics and underreporting of kala-azar in the indian state of bihar,” *Journal of theoretical biology*, vol. 262, no. 1, pp. 177–185, 2010.
- [25] A. Stauch, R. R. Sarkar, A. Picado, B. Ostyn, S. Sundar, S. Rijal, M. Boelaert, J.-C. Dujardin, and H.-P. Duerr, “Visceral leishmaniasis in the indian subcontinent: modelling epidemiology and control,” *PLoS neglected tropical diseases*, vol. 5, no. 11, 2011.
- [26] Stauch A., Duerr H.-P., Picado A., Ostyn B., Sundar S., Rijal S., Boelaert M., Dujardin J.-C., Eichner M., “Model-Based Investigations of Different Vector-Related Intervention Strategies to Eliminate Visceral Leishmaniasis on the Indian Subcontinent,” *PLOS Neglected Tropical Diseases*, vol. 8, pp. 1–9, 04 2014.
- [27] Medley G. F., Hollingsworth T. D., Olliaro P. L., Adams E. R., “Health-seeking behaviour, diagnostics and transmission dynamics in the control of visceral leishmaniasis in the Indian subcontinent,” *Nature*, vol. 528, no. 7580, pp. S102–8, 2015.
- [28] S. Mushayabasa, C. Bhunu, and M. Dhlamini, “Understanding non-compliance with multidrug therapy among leprosy patients: insights from a mathematical model,” *Understanding the Dynamics of Emerging and Re-Emerging Infec-*

tious Diseases using mathematical models. Kerala, India: Transworld Research Network, pp. 1–22, 2012.

- [29] M. O. Fofana, G. M. Knight, G. B. Gomez, R. G. White, and D. W. Dowdy, “Population-level impact of shorter-course regimens for tuberculosis: a model-based analysis,” *PloS one*, vol. 9, no. 5, 2014.
- [30] R. A. Elliott, J. A. Shinogle, P. Peele, M. Bhosle, and D. A. Hughes, “Understanding medication compliance and persistence from an economics perspective,” *Value in health*, vol. 11, no. 4, pp. 600–610, 2008.
- [31] S. Dash, P. N. Murthy, L. Nath, P. Chowdhury, *et al.*, “Kinetic modeling on drug release from controlled drug delivery systems,” *Acta Pol Pharm*, vol. 67, no. 3, pp. 217–23, 2010.
- [32] J. Urquhart, “Pharmacodynamics of variable patient compliance: implications for pharmaceutical value,” *Advanced drug delivery reviews*, vol. 33, no. 3, pp. 207–219, 1998.
- [33] M. Lipsitch and B. R. Levin, “Population dynamics of tuberculosis treatment: mathematical models of the roles of non-compliance and bacterial heterogeneity in the evolution of drug resistance,” *The International Journal of Tuberculosis and Lung Disease*, vol. 2, no. 3, pp. 187–199, 1998.
- [34] F. B. Agosto, M. I. Teboh-Ewungkem, and A. B. Gumel, “Mathematical assessment of the effect of traditional beliefs and customs on the transmission dynamics of the 2014 ebola outbreaks,” *BMC medicine*, vol. 13, no. 1, p. 96, 2015.
- [35] F. Agosto and A. Adekunle, “Optimal control of a two-strain tuberculosis-hiv/aids co-infection model,” *Biosystems*, vol. 119, pp. 20 – 44, 2014.

- [36] S. Mushayabasa and C. Bhunu, “Modeling the impact of early therapy for latent tuberculosis patients and its optimal control analysis,” *Journal of biological physics*, vol. 39, no. 4, pp. 723–747, 2013.
- [37] S. H. Farrell, J. E. Truscott, and R. M. Anderson, “The importance of patient compliance in repeated rounds of mass drug administration (mda) for the elimination of intestinal helminth transmission,” *Parasites & vectors*, vol. 10, no. 1, p. 291, 2017.
- [38] M. O. Fofana, G. M. Knight, G. B. Gomez, R. G. White, and D. W. Dowdy, “Population-level impact of shorter-course regimens for tuberculosis: A model-based analysis,” *PLOS ONE*, vol. 9, pp. 1–7, 05 2014.
- [39] F. Weiss, N. Vogenthaler, C. Franco-Paredes, and S. R. Parker, “Leishmania tropica-induced cutaneous and presumptive concomitant viscerotropic leishmaniasis with prolonged incubation,” *Archives of dermatology*, vol. 145, no. 9, pp. 1023–1026, 2009.
- [40] E. Agyingi and T. Wiandt, “Analysis of a model of leishmaniasis with multiple time lags in all populations,” *Mathematical and Computational Applications*, vol. 24, no. 2, p. 63, 2019.
- [41] N. Hussaini, K. Okuneye, and A. B. Gumel, “Mathematical analysis of a model for zoonotic visceral leishmaniasis,” *Infectious Disease Modelling*, vol. 2, no. 4, pp. 455–474, 2017.
- [42] P. Manson-Bahr, “Immunity in kala-azar,” *Transactions of the Royal Society of Tropical Medicine and Hygiene*, vol. 55, no. 6, pp. 550–555, 1961.

- [43] J. M. Medlock, K. M. Hansford, W. Van Bortel, H. Zeller, and B. Alten, “A summary of the evidence for the change in european distribution of phlebotomine sand flies (diptera: Psychodidae) of public health importance,” *Journal of Vector Ecology*, vol. 39, no. 1, pp. 72–77, 2014.
- [44] F. M. Simsek, B. Alten, S. S. Caglar, Y. Ozbel, A. M. Aytakin, S. Kaynas, A. Belen, O. E. Kasap, M. Yaman, and S. Rastgeldi, “Distribution and altitudinal structuring of phlebotomine sand flies (diptera: Psychodidae) in southern anatolia, turkey: their relation to human cutaneous leishmaniasis,” *Journal of Vector Ecology*, vol. 32, no. 2, pp. 269–279, 2007.
- [45] Thieme H. R., *Mathematics in population biology*. Princeton University Press, 2018.
- [46] P. Van den Driessche and J. Watmough, “Reproduction numbers and sub-threshold endemic equilibria for compartmental models of disease transmission,” *Mathematical biosciences*, vol. 180, no. 1-2, pp. 29–48, 2002.
- [47] A. Gumel, “Causes of backward bifurcations in some epidemiological models,” *Journal of Mathematical Analysis and Applications*, vol. 395, no. 1, pp. 355–365, 2012.
- [48] F. Brauer, “A singular perturbation approach to epidemics of vector-transmitted diseases,” *Infectious Disease Modelling*, vol. 4, pp. 115–123, 2019.
- [49] Pandey A., Mubayi A., Medlock J., “Comparing vector–host and SIR models for dengue transmission,” *Mathematical Biosciences*, vol. 246, no. 2, pp. 252 – 259, 2013.

- [50] M. J. Keeling and P. Rohani, *Modeling infectious diseases in humans and animals*. Princeton University Press, 2011.
- [51] Census Organization of India, “District census 2011,” 2015 (Accessed March 23, 2019).
- [52] S. Biswas, “Mathematical modeling of visceral leishmaniasis and control strategies,” *Chaos, Solitons & Fractals*, vol. 104, pp. 546–556, 2017.
- [53] ELmojtaba I. M., Mugisha J.Y.T., Hashim M. H. A., “Mathematical analysis of the dynamics of visceral leishmaniasis in the Sudan,” *Applied Mathematics and Computation*, vol. 217, no. 6, pp. 2567 – 2578, 2010.
- [54] Sundar S., Olliaro P. L., “Miltefosine in the treatment of leishmaniasis: clinical evidence for informed clinical risk management,” *Therapeutics and clinical risk management*, vol. 3, no. 5, p. 733, 2007.
- [55] C. S. L. B. M. Burza, S., “Leishmaniasis,” *Lancet (London, England)*, vol. 392, no. 10151, pp. 951–970, 2018.
- [56] T. P. Dorlo, M. Balasegaram, J. H. Beijnen, and P. J. de Vries, “Miltefosine: a review of its pharmacology and therapeutic efficacy in the treatment of leishmaniasis,” *Journal of Antimicrobial Chemotherapy*, vol. 67, no. 11, pp. 2576–2597, 2012.

Chapter 3

MODEL SELECTION AND ROLE OF MODEL ASSUMPTIONS FOR TREATMENT NON-ADHERENCE ON VISCERAL LEISHMANIASIS ELIMINATION

3.1 Introduction

3.1.1 WHO-led VL elimination target

In 2005, the governments of India, Bangladesh, and Nepal in collaboration with the WHO launched a regional initiative to eliminate Visceral Leishmaniasis by 2015. Elimination was defined as reducing incidence to a level at which it would cease to be of public health importance i.e. less than one per 10,000 inhabitants per year at sub-district levels. Due to failure in attainment of the targets, subsequent target dates have been 2015, 2017, 2020 and now WHO has published a road map for VL until the year 2030 (1). The national strategy for the elimination of VL, which is in line with the WHO Regional Strategic Framework for elimination of Kala-Azar from the South-East Asia Region (2011-2015), includes early case detection, integrated vector management, supervision, monitoring and surveillance, strengthening human resource capacity for health, programme management etc. (2). Elimination is feasible in the Indian subcontinent because VL is anthroponotic (i.e. humans are the only known reservoirs), availability of drugs with high treatment efficacy, limited and clustered geographical distribution of cases and a strong political commitment and inter-country collaboration to control VL cases (3). Vector control interventions are considered to be most effective in controlling this vector-borne disease. Main efforts

towards elimination include integrated vector management (optimal and sustainable vector screening and control) and treating infected individuals.

3.1.2 *Sandfly control interventions:*

Several sophisticated vector controls are being implemented in India to achieve the VL elimination goal. The most common are Indoor Residual Spraying (IRS) to control adult sandflies, source reduction, treatment of breeding sites with chemical, biological agents and Long Lasting Insecticidal Nets (LLINs) or Insecticide Treated Nets (ITNs) for personal protection using bed nets. Environmental Vector Management (EVM) or Larval Source Management (LSM) is implemented to reduce the sandfly and larva density in and around the house (4).

IRS effect lasts for about 10 weeks and hence is applied twice a year before and after monsoon since sandfly density peaks around then. For the IRS, 150 grams insecticides per 75 square feet is recommended. The insecticides used are DDT (DichloroDiphenylTrichloroethane) 50% WP (weight of product), Malathion 25% WP and synthetic pyrethroids. Synthetic pyrethroids include Deltamethrin 2.5% WP, Cyfluthrin 10% WP, Lambdacyhalothrin 10% WP and Alphacypermethrin 5% WP. These are also injected in bednets to make them LLINs. LLINs holes are big enough for male sandflies and unfed female sandflies to pass through, but prevent the infecting fed female sandflies. These nets are distributed for free in India. It has been identified that cracks in mud walls in houses, dense vegetation and animal burroughs are some of the popular places of sandfly breeding, nesting and resting. Thus through LSM, the places are chemically treated or more popularly the cracks in house walls are plastered and limed (5; 6).

The effect of these vector controls are sensitive to their implementation and use. This study will use the effects of these vector controls in terms of (i) reduction in

vector biting rate, (ii) reduction in recruitment rate of adult female sandflies, and, (iii) increased mortality rate of adult female sandflies. Although we have considered fixed values for the parameters corresponding to these effects from (6), in later sections, we provide global sensitivity of the reproduction number on the parameter values.

3.1.3 *Non-Adherence to the Treatment of VL*

Causes and Effects of non-adherence to VL treatment : Bihar is one of the poorer states in India and patients do not strictly adhere to the treatment due to the fear of loss of wages and livelihood. Other causes of non-adherence in patients generally is cost of drugs, side-effects, “I am cured” syndrome in which patients stop the treatment upon remittance of symptoms, difficult access to the sparsely located health centers, health and disease illiteracy etc. (7; 8; 9). Kansal et. al. (2017) traced and interviewed defaulters in Muzaffarpur region to identify self-stated causes of non-adherence specific to the VL treatment (10). These causes are “Wanted to have second opinion”, “Preference for KA specialist”, due to other illness, Side effects of drug, Felt better after starting treatment, Outstation duties during treatment, PHC is too far from home, Dissatisfied with the behaviour of PHC staff and treatment, Financial problem and Personal reasons (marriage, death, festival). Miltefosine is the only oral drug for VL and its 28-day regime is prescribed as first-line treatment. It can sometimes cause gastrointestinal side-effects. It stays in the body for a very long time, which could potentially make the parasite resistant to it (3). According to a study (11), the main reported reasons for treatment interruption were lack of money for treatment (68.7%) and side effects (15.7%). The long duration of the treatment also leads to increased possibility of non-adherence. For any treatment, adherence is crucial because non-adherence leads to morbidity, mortality, drug resistance etc. and results in loss in terms of health, money, facilities and overall quality of life (12; 13).

There are various studies on the role of non-adherence to the treatment for diseases like HIV, malaria, Lymphatic Filariasis, Soil-transmitted Helminthiasis etc. and how it is detrimental to the reduction of disease prevalence and spread, however, there is no such study for VL in India. Due to the complex nature of various causes of treatment non-adherence to VL, the distribution of non-adherence may be different in different regions. Therefore, we derive a novel data-driven model to capture non-adherence behavior. Furthermore, since we established the importance of treatment non-adherence in the previous chapter, we build an extension to the model in previous chapter to incorporate the perfectly adhering patients separately from the treatment non-adherers to examine the impact of increasing perfect adherence on the potential for VL elimination in presence of current vector controls.

3.1.4 Treatment non-adherence and case underreporting in Bihar

This paper mainly focuses on spread and control of VL in Bihar, India because it is estimated that 90% VL cases of India are from Bihar (14). Reportedly, there has been a decline in disease burden with a peak of 80,000 cases in 1992 to less than 9,000 in 2015. But multiple studies (15; 16; 17; 18) highlight the current under-estimation of neglected tropical disease cases and its adverse effects on the mortality rate as well as DALYs (disability-adjusted life years). Furthermore, the serious under-reporting of cases (as high as 90% (19)) reported and estimated in (20; 21; 22; 23) result in increasing difference in infected cases and reported cases as the cases increase (24). Singh et. al. (2006) point out that the fault lies in the reporting system which picks up only those VL cases which are registered for treatment with the public health care delivery system (PHC), District Hospital and Government Medical colleges leaving out a vast majority of patients who opt for the private health care system (25; 26; 22). The number of cases does not also include the number of non-adherent individuals

who may be clinically resolved but not completely recovered and hence infectious, thus a potential for transmission. These individuals pose a similar threat as the PKDL (Post Kala-azar Dermal Leishmaniasis) cases (VL reservoirs) (27). Therefore, current challenges in controlling VL in Bihar include (but may not be limited to) delay in seeking health-care, varying treatment adherence levels (28), synchronizing multiple vector control programs, managing reservoirs, availability and supply of drugs and poor surveillance (29).

Even though studies (30; 29) show that non-adherence to treatment of VL and VL cases have reduced over the years, only around 30% of the patients go to the public health center for the treatment and those who receive treatment fail to follow up as prescribed by practitioners due to socio-economic constraints and negligence (11). Mondal et. al, (2009) suggest that geographical inaccessibility for village health workers, indigenous healers, and prescription by local chemists could be primary factors for negligence in accessing and following proper treatment, but for selecting between private and public sector the most frequently mentioned factors were *faith* (belief that VL can be treated adequately) and *good interpersonal communication*. The surveillance data used for making policies and understanding the magnitude of the disease have started including cases from private sectors only recently and not much is known about the coverage. Given that a large population seeks health-care at private clinics, the result that the disease and non-adherence is reducing must be re-evaluated.

Different behavioral aspects underlying successful treatment and recovery of a patient is summarized in Figure 3.1 out of which (31) stated the importance of early health-care seeking in reducing VL cases. Debroy et. al. (2016) reviewed the modelling studies on VL to understand the factors (divided into 6 categories: atmosphere, access, availability, awareness, adherence and accedence) that were identified and ad-

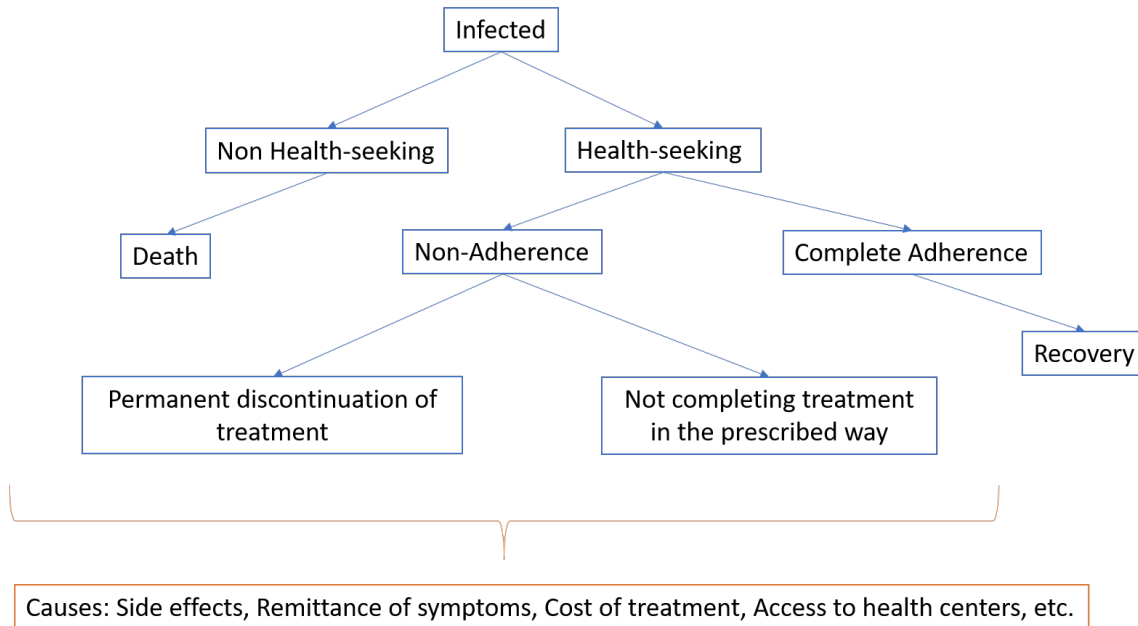

Figure 3.1: Flowchart of Behavioral Aspects in Treatment and Health-Seeking

dressed for controlling the disease and eliminating it from the South-east Asian region (32). They remark that there exists few or no mathematical modeling studies focusing primarily on non-adherence to treatment VL. Therefore, this paper will highlight and model the non-adherence to the treatment of VL to emphasize on its adverse effects resulting in it being a hindrance in its elimination.

3.1.5 Goal of this paper

We analyze the impact of treatment non-adherence on the dynamics and potential elimination of VL via the results of following research questions:

1. Probability of VL treatment non-adherence is highest after one week of treatment and therefore the average waiting time in treatment approximates a gamma distribution. In this context, what is the critical level treatment non-adherence

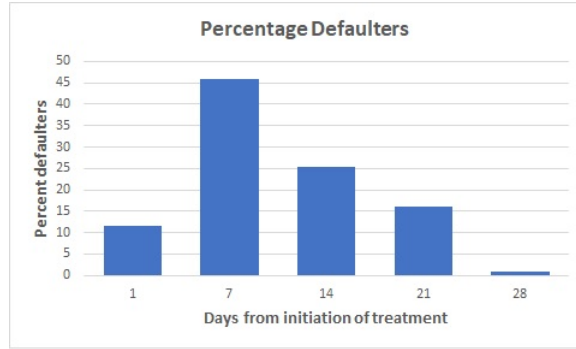

Figure 3.2: Percent defaulters at different stages during the treatment. Source of data: (10)

rate above which VL elimination is impossible when treatment is the only control?

2. Treatment non-adherers have different treatment behavior and infectivity as compared to the newly infected population. Considering this difference, how to compare the mechanisms in this new model with the previous model?
3. When treatment non-adherers are explicitly modeled, what is the critical proportion of perfect treatment adherence below which elimination is impossible in combination with current vector control?

3.2 Methods

3.2.1 Data-driven non-adherence model (Model I)

Gamma-distributed Treatment Non-adherence

Treatment non-adherence has been modeled for tuberculosis and leprosy as $T' = rT$ (33; 34). We used the similar structuring in the previous chapter. This modeling structure results in exponentially distributed probability of leaving treatment class. However, as seen from Figure 3.2 (Kansal et. al., 2017), the proportion of treatment

non-adherence peaks around 7 days since treatment initiation. In this chapter, conclusions drawn are mostly simulation-based and hence we take the complete model from the previous chapter (without any assumptions for special cases), and extend it to incorporate this difference in distribution. We found out this proportion of non-adherence's best-fit gamma distribution ($Gamma(\alpha = 1.118, \beta = 1.174)$). Best fit exponential distribution for the same is $Exponential(\lambda = 0.15)$ (Figure 3.3). The parameters of these distributions were computed using weighted mean and variance of the data presented in Figure 3.2 (Refer to Appendix D for calculations). It was seen that Pearson's χ^2 statistic for the exponential distribution equals approximately 101 times that of the gamma distribution with the Akaike Information Criterion (AIC) for the former being greater than the latter. Thus, we can conclude that gamma-distribution describes the non-adherence better.

Modeling Framework

“Linear chain trick” is used to obtain gamma-distributed waiting time using ODE model (35). It is based on the principle that the sum of n identical exponential probability density functions converges to a gamma probability density function as $n \rightarrow \infty$. As shown in Figure 3.4, VL transmission is modeled such that susceptible human population (S_H) gets infected (I_H) upon infected sandfly (I_V) bite(s) at a rate $b\beta_{VH}S_H\frac{I_V}{N_V}\frac{N_V}{N_H}$, where N_H and N_V are the total human population and the total vector population density respectively. A susceptible sandfly (S_V) gets infected at a rate $b\beta_{HV}S_V\frac{I_H}{N_H} + \alpha\frac{\sum_i T_i}{N_H}$ if it bites an infectious human. In this case, the population in infected class and treatment classes are infectious; latter due to treatment non-adherence. b is the average biting rate per sandfly, β 's are infection transmission coefficients and $\alpha \in [0, 1]$ is a scaling factor to indicate the relative infectivity of the patients with respect to infected populations that are not in treatment. Assuming

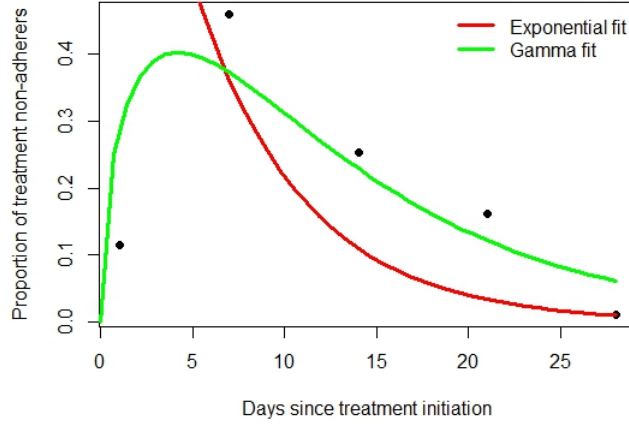

Figure 3.3: Comparison between best fit exponential and gamma distributions for the probability of leaving treatment. $Exponential(\lambda = 0.15)$. $Gamma(\alpha = 1.118, \beta = 1.174)$. The Pearson's χ^2 statistic for the exponential distribution equals to approximately 101 times that of the gamma distribution with the Akaike Information Criterion for former being greater than the latter.

that the disease deaths due to VL are negligible (due to enforcement of treatment to every diagnosed individual), an infected individual seeks treatment at the rate γ_H and enters treatment to move through the stages T_i , $i = 1, 2, \dots, n$. He/she is in treatment for a $\Gamma(n, n(\theta_1 + \rho))$ -distributed time where θ_1 is the rate of defaulting from the treatment during the n stages. This means that the expected average treatment period is $1/(\theta_1 + \rho)$, its standard deviation is $1/(\theta_1 + \rho)\sqrt{n}$ and the squared coefficient of variation is $1/n$. The person recovers from the infection only upon completing all the treatment stages without defaulting midway. Furthermore, humans and sandflies are born into S_H and S_V compartments at constant rates Λ_H and Λ_V respectively and their average per capita death rates are μ_H and μ_V respectively.

The system of equations describing the above mechanistic framework is:

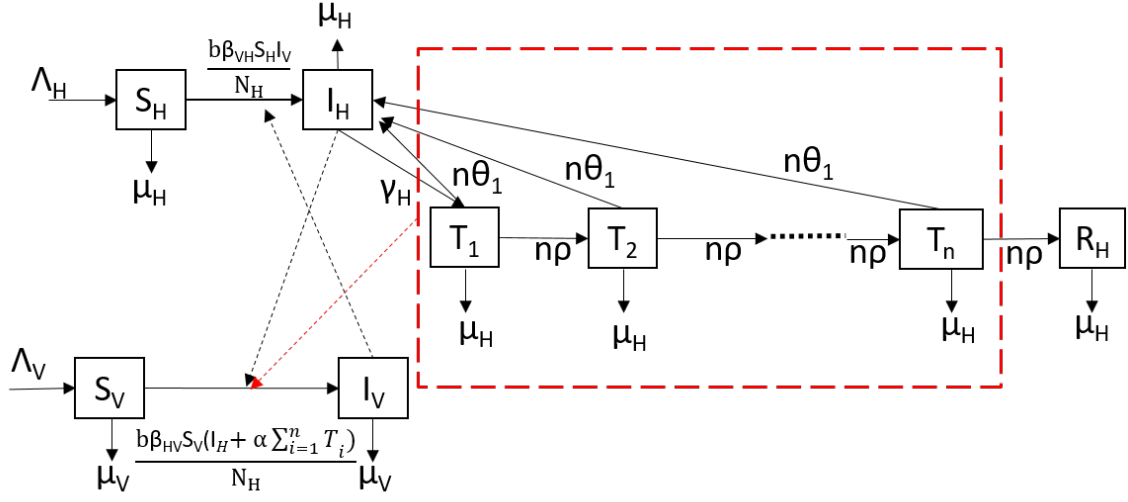

Figure 3.4: *Data-driven Non-adherence Model: Stage Progression Model for VL Dynamics with Gamma-Distributed Treatment Non-Adherence*

$$\frac{dS_H}{dt} = \Lambda_H - b\beta_{VH}S_H\frac{I_V}{N_H} - \mu_H S_H \quad (3.1)$$

$$\frac{dI_H}{dt} = b\beta_{VH}S_H\frac{I_V}{N_H} - \gamma_H I_H - \mu_H I_H + n\theta_1 \sum_{i=1}^n T_i \quad (3.2)$$

$$\frac{dT_1}{dt} = \gamma_H I_H - n(\theta_1 + \rho)T_1 - \mu_H T_1 \quad (3.3)$$

$$\frac{dT_i}{dt} = n\rho T_{(i-1)} - n(\gamma_H + \alpha)T_i - \mu_H T_i \quad 2 \leq i \leq n \quad (3.4)$$

$$\frac{dT_H}{dt} = n\rho T_n - \theta_2 T_H - \mu_H T_H \quad (3.5)$$

$$\frac{dR_H}{dt} = \theta_2 T_H - \mu_H R_H \quad (3.6)$$

$$\frac{dS_V}{dt} = \mu_V N_V - b\beta_{HV}S_V\frac{I_H + \alpha n \sum_{i=1}^n T_i}{N_H} - \mu_V S_V \quad (3.7)$$

$$\frac{dI_V}{dt} = b\beta_{HV}S_V\frac{I_H + \alpha n \sum_{i=1}^n T_i}{N_H} - \mu_V I_V \quad (3.8)$$

where $N_H = S_H + I_H + \sum_{i=1}^n T_i + T_H + R_H$ and $N_V = S_V + I_V$ are constant for $N_H = \Lambda_H/\mu_H$ and $N_V = \Lambda_V/\mu_V$.

3.2.2 *Explicit Treatment Adherence Model (Model II)*

Explicit Incorporation of Treatment Non-adherers

The treatment behavior and infectivity of the treatment non-adherers is not necessarily equivalent to the newly infected people. Therefore, non-adherers flowing back into the I_H compartment incapacitates the modeler to incorporate this difference in treatment behavior. Treatment adherence in Nepal = 83% with only 53.9% perfect adherence (13). Quantifying perfect treatment adherence for Bihar is not possible with the current compartmentalization (Model I). Furthermore, asymptomatic infectious cases arise out of partial treatment (i.e. when treatment non-adherence happens upon the resolution of symptoms).

Modeling Framework

We develop an alternative vector-host model to incorporate the difference in treatment behavior between newly infected populations and treatment non-adherers (Figure 3.5). Humans and sandflies are born into S_H and S_V compartments at constant rates Λ_H and Λ_V respectively and their average per capita death rates are μ_H and μ_V respectively. Sandfly-to-human VL transmission happens similar to as in Model I. In Model II, human-to-sandfly transmission can happen when a susceptible sandfly bites either a newly infected human (I_H) or treatment non-adherer who is asymptomatic but infectious (V_H). We assume the patients (T_H and C_H) indulge in safety precautions to avoid sandfly bites and therefore are not infectious.

Similarly as Model I, assuming that the disease deaths due to VL are negligible (due to enforcement of treatment to every diagnosed individual), an infected individual seeks treatment at the rate γ_H . ϕ proportion of health-seeking individuals are assumed to practice “perfect adherence”, i.e. treatment is taken exactly as pre-

scribed in the first time and thus enter C_H . People in C_H complete the treatment in 28 days (Miltefosine) as prescribed. The non-adhering proportion $(1 - \phi)$ enters T_H wherein average duration in treatment is shorter due to non-adherence upon symptom resolution. The asymptomatic infectious treatment non-adherers (V_H) reinitiate the treatment at the per capita rate η when symptoms reappear. $(1 - \xi)$ proportion of these people will enter C_H to now complete the treatment as prescribed. We assume that the people reinitiate treatment after at least 15 days and hence are prescribed the complete 28-day regime from the beginning.

Note that, in this modeling framework, the treatment non-adhering populations T_H and V_H are falsely reported as treated cases and are hidden and this contribute to underreporting of cases.

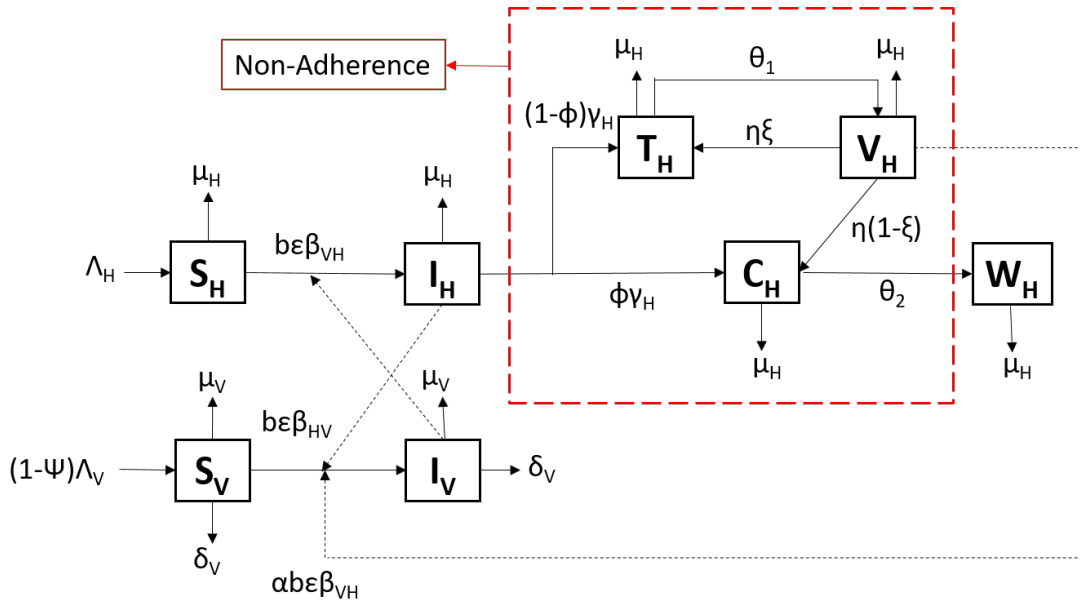

Figure 3.5: *Explicit Treatment Adherence Model*: Flowchart of VL Dynamics with Explicit Incorporation of Treatment Non-Adherers and with Vector Control.

Incorporating the effect of vector control: Sophisticated vector controls (LLIN, LSM, IRS) have been implemented in Bihar. To analyze potential for elimination, it is important to consider the effect of the ongoing vector control interventions. These interventions' effect is captured in Model II (Figure 3.5) as: (1) biting rate b reduced by a factor $\epsilon \in [0, 1]$; (2) sandfly mortality due to insecticide δ_V ; (3) Reduction in the rate of recruitment of susceptible adult sandflies ($\Lambda_V(1 - \psi)$).

The system of equations describing the above mechanistic framework along with the vector controls is:

$$\frac{dS_H}{dt} = \Lambda_H N_H - b\epsilon\beta_{VH}S_H \frac{I_V}{N_H} - \mu_H S_H \quad (3.9)$$

$$\frac{dI_H}{dt} = b\epsilon\beta_{VH}S_H \frac{I_V}{N_H} - \gamma_H I_H - \mu_H I_H \quad (3.10)$$

$$\frac{dT_H}{dt} = (1 - \phi)\gamma_H I_H - \theta_1 T_H + \xi\eta V_H - \mu_H T_H \quad (3.11)$$

$$\frac{dV_H}{dt} = \theta_1 T_H - \eta V_H - \mu_H V_H \quad (3.12)$$

$$\frac{dC_H}{dt} = \phi\gamma_H I_H + (1 - \xi)\eta V_H - \theta_2 C_H - \mu_H C_H \quad (3.13)$$

$$\frac{dW_H}{dt} = \theta_1 C_H - \mu_H W_H \quad (3.14)$$

$$\frac{dS_V}{dt} = \Lambda_V(1 - \psi)N_V - (b\epsilon\beta_{HV}I_H + \alpha b\epsilon\beta_{HV}V_H) \frac{S_V}{N_H} - \mu_V S_V - \delta_V S_V \quad (3.15)$$

$$\frac{dI_V}{dt} = (b\epsilon\beta_{HV}I_H + \alpha\epsilon b\beta_{HV}V_H) \frac{S_V}{N_H} - \mu_V I_V - \delta_V I_V \quad (3.16)$$

3.2.3 Are Model I and Model II Mechanistically Equivalent?

We want to assess if under the respective assumptions, are Models I and II mechanistically different. However, both models are of high dimensions and complex. To compare them, they must be reduced to optimally minimum compartments (that is without losing the treatment aspects) so that they are structurally equivalent enough to be compared.

Reduction of Model I

Using the data of defaulters, defined as who discontinued treatment from a PHC (Public health center), by (10) as represented in Figure 3.2, we calculate the average period of time patients remain in treatment. The average period in treatment, $1/(\theta_1)$ (=10.575 days), is calculated with weighted ties of people leaving treatment at a particular point of time. Therefore, using the variance of the distribution, the number of stages is

$$variance = \frac{1}{n\theta_1^2} = 40.36 \implies n = \frac{10.575^2}{40.36} \approx 3$$

Therefore, the Model I with $n = 3$ can be reduced to a 6 compartment model as shown in Figure 3.7. The assumptions in doing so are that the compartment \hat{T} is the combination of T_1 , T_2 and T_3 classes while preserving the reproduction number of the original model. The parameter scaling as shown below ensures this condition:

$$\theta_1'' = \theta_1$$

That is, average treatment non-adherence rate is preserved.

$$\rho'' = \rho$$

That is, the average recovery rate is preserved.

$$\alpha'' = F(\alpha, \theta_1, \rho)$$

$$\alpha'' = \frac{\alpha (9\theta_1^2 + 6\theta_1\mu_H + 27\theta_1\rho + \mu_H^2 + 9\mu_H\rho + 27\rho^2) (\gamma_H(\mu_H + \rho) + \mu_H(\theta_1 + \mu_H + \rho))}{\gamma_H (9\theta_1^2\mu_H + 3\theta_1\mu_H(2\mu_H + 9\rho) + (\mu_H + 3\rho)^3) + \mu_H(3\theta_1 + \mu_H + 3\rho)^3} + \frac{\theta_1 (9\theta_1^2(2\mu_H + 3\rho) + 3\theta_1 (4\mu_H^2 + 24\mu_H\rho + 27\rho^2) + 2\mu_H^3 + 21\mu_H^2\rho + 81\mu_H\rho^2 + 54\rho^3)}{\gamma_H (9\theta_1^2\mu_H + 3\theta_1\mu_H(2\mu_H + 9\rho) + (\mu_H + 3\rho)^3) + \mu_H(3\theta_1 + \mu_H + 3\rho)^3}$$

such that the reproduction number of the original model with $n = 3$, is equal to the reduced model.

Reduction of Model II

First, we consider Model II without vector so that it can be compared with Model I. That is consider the model in Figure 3.6 which is derived from original Model II with $\delta_V = 0$, $\psi = 0$ and $\epsilon = 1$ in Figure 3.1.

Next, we reduce the model to a minimal number of compartments while still capturing treatment behavior well. We do this by combining the compartments T_H and V_H into T , i.e. T will now be the class which contains all treatment non-adherers until before they enter C_H to successfully complete the prescribed treatment. The flowchart of the reduced model can be seen in Figure 3.8. The new average waiting time in T before entering C_H is computed by considering all routes of going from T_H to C_H as follows:

$$\begin{aligned} \frac{1}{\eta'_1} &= \frac{\theta_1}{\theta_1 + \mu_H} \frac{1}{\eta(1 - \xi)} + \frac{\theta_1}{\theta_1 + \mu_H} \frac{\eta\xi}{\eta + \mu_H} \frac{\theta_1}{\theta_1 + \mu_H} \frac{1}{\eta(1 - \xi)} + \dots \\ &\implies \eta'_1 = \left(\mu_H \left(\frac{1}{\eta + \mu_H} + \frac{1}{\theta_1} \right) + \frac{\eta(1 - \xi)}{\eta + \mu_H} \right) (1 - \xi)\eta \end{aligned}$$

And, the scaling down of infectivity coefficient of the new non-adherent class:

$$\alpha' = \frac{\theta_1}{\theta_1 + \mu_H} \frac{\mu_H + \eta'_1}{\mu_H + \eta \left(1 - \frac{\theta_1 \xi}{\theta_1 + \mu_H} \right)} \alpha$$

makes sure that the reproduction number of the original Model II with no vector control is preserved in the reduced model.

3.3 Results

3.3.1 Parameter Estimates

For both models I and II, for initial conditions initial number of infected people is assumed to be 8500 and everyone else susceptible (2). The parameters same and common for both models I and II are: natural mortality of humans (μ_H) and sandflies

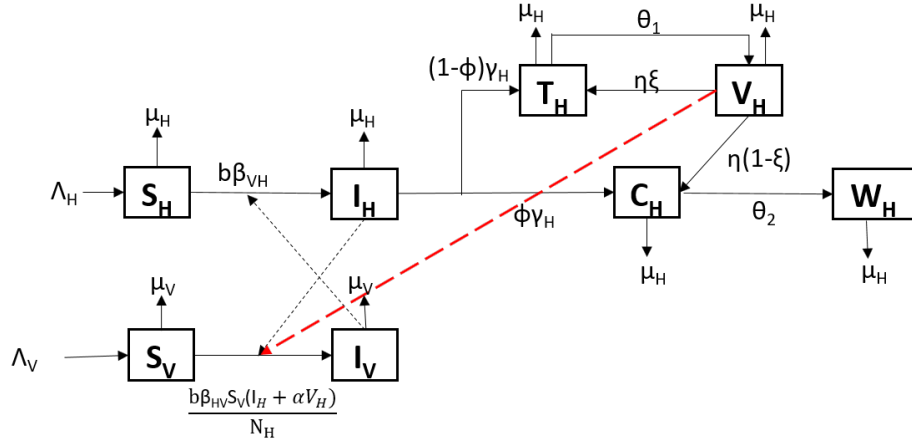

Figure 3.6: Flowchart of Model II with No Vector Control. That is $\delta_V = 0$, $\psi = 0$ and $\epsilon = 1$ in Figure 3.1

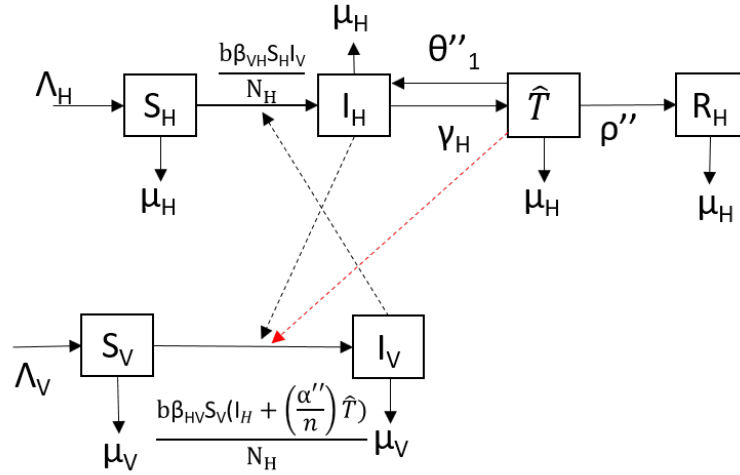

Figure 3.7: Model I (data driven implicit gamma-distributed treatment non-adherence) reduced as described in Section 3.2.3 so that threshold measure (reproduction number) is preserved.

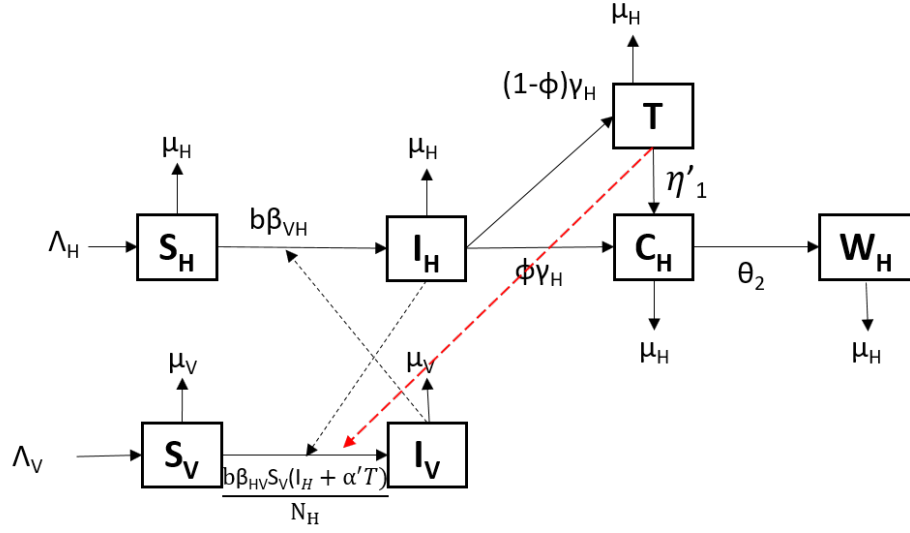

Figure 3.8: Model II (explicit treatment non-adherence) reduced as described in Section 3.2.3 so that threshold measure (reproduction number) is preserved.

Variable	Definition
S_H	Number of susceptible hosts
I_H	Number of infected hosts
T_i	Number of hosts in the i^{th} stage of treatment for $1 \leq i \leq n$
R_H	Number of recovered hosts due to complete treatment
S_V	Density of susceptible vectors
I_V	Density of infectious vectors

Table 3.1: Variable Description for Model I.

Variable	Definition
S_H	Number of susceptible hosts
I_H	Number of infected hosts
T_H	Number of hosts non-adherent to the treatment
C_H	Number of host adhering to the treatment
V_H	Number of hosts in clinically resolved state
W_H	Number of completely recovered hosts
S_V	Density of susceptible vectors
I_V	Density of infectious vectors

Table 3.2: Variable Description for Model II.

(μ_V), vector biting rate (b), total population of Bihar (N_H), infection transmission coefficients for human-to-vector (β_{HV}) and vector-to-human (β_{VH}), and, treatment initiation rate (γ_H ; inverse of average number of days (98 days) taken by a symptomatic patient to start the treatment (36)). The point estimates for these obtained from literature are shown in the Table 4.4.

Model I

- *Treatment non-adherence rate*: The total treatment non-adherence rate θ_1 is computed as the inverse of total time patients spend in treatment before defaulting (10.575 days, (10)).
- *Coefficient of infectivity of patients*: The parameter α is the scaling parameter of how infectious patients are as compared to the newly infected people and

lies between 0 and 1. The value for this parameter has not been estimated in literature and hence will be varied in the study.

- *Rate of progression in next treatment stage:* The average total rate ρ at which a patient in T_i progresses in T_{i+1} to eventually be adhering and go in C_H class. Since $n = 3$ as shown in previous sections, ρ can be computed as the inverse of total treatment duration (28 days for MIL).

Model II

- *Adherence proportion:* As estimated in the previous chapter (based on data from Kansal et. al., 2017) proportion of treatment non-adherence $((1 - \phi))$ is 0.16. Using the data from (10) for patients who eventually complete the treatment (after defaulting), ξ was calculated to be 0.862. The value for the rate of defaulting (i.e. for how many days a person stays in treatment before defaulting), the weighted mean for defaulting data from (10) over 28 days was taken to calculate θ_1 to be approximately 0.095.
- *Vector control parameters:* The values for parameters $(\delta_V, \epsilon, \psi)$ related to the vector control program (IRS, LLIN and Larval source management respectively) were calculated to be 0.319, 0.563 and 0.58 respectively from a cluster study (6).

Since no study has recorded the average delay in resuming or restarting the treatment, we varied the value for η from 0 to 1. This is a novel work testing the effect of clinically recovered but infectious individuals on the dynamics of the disease, therefore the value of α in Model II was chosen from range 0 to 1. Table 3.3.3 summarizes parameters' description and values.

3.3.2 Bifurcation Analysis

Reproduction number for Model I:

$$R_c^2 = \frac{b\beta_{HV}}{\mu_V} \frac{N_V}{N_H} b\beta_{VH} \left(\frac{1 + \frac{\alpha\gamma_H}{n\theta_1+n\rho+\mu_H} \sum_{i=0}^{n-1} \left(\frac{n\rho}{n\theta_1+n\rho+\mu_H}\right)^i}{\mu_H + \gamma_H \left(\left(\frac{\mu_H+n\rho}{\mu_H+n\rho+n\theta_1}\right)^n + \frac{\mu_H}{(\mu_H+n\rho+n\theta_1)^n} \sum_{i=1}^{n-1} (n\theta_1)^{n-i} \sum_{j=1}^i (n\rho)^{j-1} (n-j)(\mu_H+n\rho)^{j+1}\right)} \right)$$

For $n = 3$, the reproduction number is

$$R_c^2 = \frac{b^2\beta_{HV}\beta_{VH}N_V (\alpha\gamma (9\theta_1^2 + 6\theta_1\mu_h + 27\theta_1\rho + \mu_h^2 + 9\mu_h\rho + 27\rho^2) + (3\theta_1 + \mu_h + 3\rho)^3)}{\mu_V N_H (\gamma (9\theta_1^2\mu_h + 3\theta_1\mu_h(2\mu_h + 9\rho) + (\mu_h + 3\rho)^3) + \mu_h(3\theta_1 + \mu_h + 3\rho)^3)}$$

And endemic equilibrium:

$$I_H^* = \frac{\Lambda_H(R_c^2 - 1)}{R_c^2(\mu_H + \frac{R_c^2 N_H}{b\beta_{VH}N_V})}$$

Reproduction number for Model II: $\tilde{R}_c^2 = \frac{b\epsilon\beta_{HV}}{\gamma_H+\mu_H} \frac{b\epsilon\beta_{VH}}{\mu_V+\delta_V} \frac{N_V}{N_H} \left(1 + \frac{\alpha\gamma_H\theta_1(1-\phi)}{(\theta_1+\mu_H)(\eta+\mu_H)-\eta\theta_1\xi}\right)$

And endemic equilibrium:

$$I_H^* = \frac{b\epsilon\beta_{VH}(1-\psi)N_V N_H \mu_H (\tilde{R}_c^2 - 1)}{\tilde{R}_c^2(\mu_H + \gamma_H)(b\epsilon\beta_{VH}(\mu_V + \delta_V N_V(1-\psi) + N_H))}$$

Remark: Since both reproduction numbers were computed using the next generation matrix method (37; 38), the corresponding disease-free equilibria (that is all compartments except susceptible classes have zero number) is locally stable for the reproduction numbers less than 1 for a low enough initial prevalence. Note that the reproduction numbers are functions of the treatment- and vector control-related parameters thus impacting the elimination threshold.

3.3.3 Model I and Model II are Mechanistically NOT Equivalent

Upon reduction of Models I and II as shown in Section 3.2.3, the comparison can be made as shown in Table 3.3.

Model I	Model II
\hat{I}_H consists of newly infected as well as treatment non-adherent people	I_H consists of newly infected people only
Non-adherence captured as a rate θ_1''	Non-adherence captured as proportion $(1 - \phi)$
Perfect treatment adherence cannot be explicitly quantified	Per capita perfect treatment adherence rate is $\phi\gamma_H$
\hat{T} compartment consists of both treatment adherers and non-adherers.	T compartment consists of treatment non-adherers.
True prevalence is $\hat{I}_H + \hat{T}$; Reported prevalence is \hat{T}	True prevalence is $I_H + T + C_H$; Reported prevalence is $T + C_H$
True incidence is $b\beta_{VH}S_H I_V/N_H$; Reported incidence is $\gamma_H \hat{I}_H$	True incidence is $b\beta_{VH}S_H I_V/N_H$; Reported incidence is $\gamma_H I_H$
Total rate of treatment completion is $\rho'' \hat{T}$	Total rate of treatment completion is $\eta_1' T + \phi\gamma_H I_H$
Average time spent in \hat{I}_H before treatment completion: $\frac{\gamma_H}{\mu_H + \gamma_H} \frac{1}{\rho''} \cdot \frac{\theta_1'' + \rho'' + \mu_H}{\gamma_H(\rho'' + \mu_H) + \mu_H(\theta_1'' + \rho'' + \mu_H)}$	Average time spent in I_H before treatment completion: $\frac{1}{\phi\gamma_H} + \frac{(1-\phi)\gamma_H}{\mu_H + \gamma_H} \frac{1}{\eta_1'}$

Table 3.3: Comparison of the reduced versions of Model I (Figure 3.7) and Model II (Figure 3.8).

Parameter	Definition
Λ_H	Human birth rate
Λ_V	Adult sandflies recruitment rate
b	Average biting rate of sandflies per human
θ_1	Per capita rate of patients not adhering to treatment
γ_H	Per capita rate of infected humans initiating the treatment
β_{HV}	Infection coefficient from host to vector
β_{VH}	Infection coefficient from vector to host
θ_2	Per capita recovery rate of humans upon complete treatment
μ_H	Per capita human natural mortality rate
μ_V	Per capita sandfliy mortality rate
α	Scaling factor for infection coefficient of patients as compared to infected people not under treatment
n	Number of treatment stages

Table 3.4: Parameter Description for Model I.

Begin of Table

Parameter	Definition	Value estimate	Source
Λ_H	Human birth rate	$0.0015875 \times N_H$ day^{-1}	(39)
Λ_V	Sandflies birth rate	$0.299 \times N_V$	day^{-1} (39)
N_H	Total host population	4.8 million	(40)
N_V	Total vector population	$0.75 \times N_H$	(41)
b	Average biting rate of sandflies per human	0.2856	day^{-1} (39)
θ_1	Per capita rate of defaulting mid-treatment	0.095	day^{-1} (10)
γ_H	Per capita treatment rate of newly infected humans	0.175	day^{-1} (11)
β_{HV}	Infection probability from host to vector	$1/98$	day^{-1} (31)
β_{VH}	Infection probability from vector to host	0.0714	day^{-1} (39)
θ_2	Per capita permanent recovery rate (through Miltefosine 28-day regime)	0.036	day^{-1} (42)
μ_H	Per capita human natural mortality rate	0.00004	day^{-1} (39)

Continuation of Table 4.4

Parameter	Definition	Value estimate	Source
μ_V	Per capita sandfly mortality rate	0.189 day^{-1}	(39)
ϵ	Reduction in biting rate due to LLINs	0.563	(6)
ϕ	Probability of complete adherence	0.837	(10)
ψ	Per capita mortality rate of sandfly larvae due to LSM	0.58 day^{-1}	(6)
δ_V	Per capita mortality rate of vectors due to IRS	0.319	(6)
ξ	Proportion of resuming treatment	0.862	(10)
α	Proportion of infection transmission from V_H	0 to 1	Assumed
η	Proportion of resuming treatment	0 to 1	Assumed

Table 3.5: Parameter Description and Estimates for Model II.

End of Table

3.3.4 Effect of Treatment Adherence on Elimination

Model I

Using Model I with three treatment stages ($n = 3$) to compare the VL outcome with current non-adherence rate $\theta_1 = 1/10.575$ with the outcomes with reduced treatment

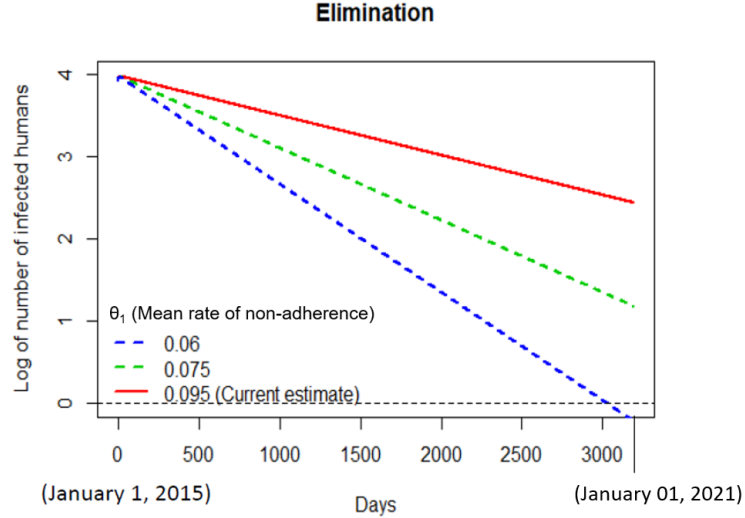

Figure 3.9: Effect of decreasing treatment non-adherence rate on potential VL elimination from Bihar by 2021 based on Model II (Figure 3.4).

non-adherence. Note that reducing θ_1 implies increasing the average waiting time of treatment non-adherers in the treatment. We can see that this waiting time can be increased to successful VL elimination in the future (Figure 3.9).

Model II

Model II (Figure 3.1) considers the complete model with consideration of non-adherence and vector control both.

Figure 3.10 sheds light on the underreporting of the non-adherent patients as infected cases. As the infectivity (α) of the non-adherent patients increases compared to the infectivity of new cases, reported number of new cases also increase, but for all values of α it can be seen that the proportion of reported cases is lower than real number of cases by a significant percentage.

The lines in Figure 3.11 represent the relation of levels of non-adherence to treatment (ϕ) in population with rate of resuming treatment after non-adherence (η) at

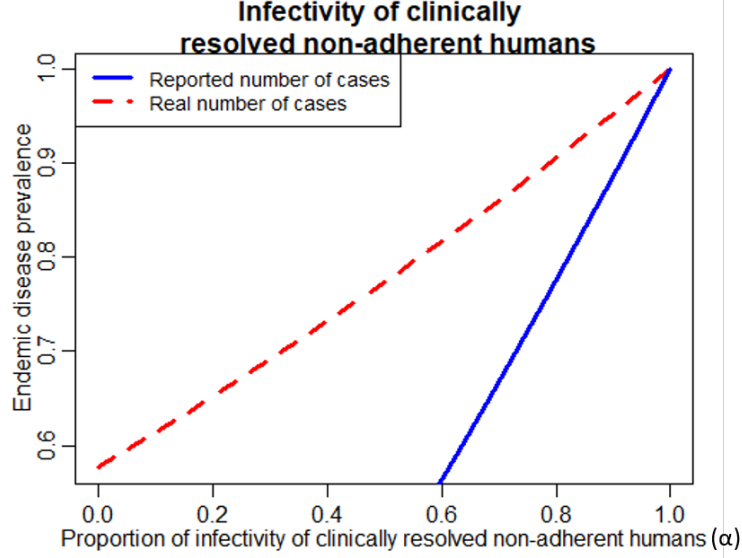

Figure 3.10: Under-reporting of cases due to non-adherence to treatment. Solid line i.e. “Reported number of cases” represents only the new infected cases ($\frac{I_H^*}{I_{H\alpha=1}^*}$) and dashed line i.e. “Real number of cases” represents the new infections as well as non-adherent patients who are infectious in the population ($\frac{I_{H\alpha}^* + V_{H\alpha}^*}{I_{H\alpha=1}^* + V_{H\alpha=1}^*}$).

$R_0 = 1$ for different levels of infectivity of the non-adherent patients (α). This relation is given by the following equation

$$\eta = \frac{\mu_H(\theta_1 + \mu_H)}{\theta_1(1 - \xi) + \mu_H - \frac{\alpha\theta_1(1-\phi)}{R_1-1}}$$

where

$$R_1 = \frac{(\mu_V + \delta_V)^2(\gamma_H + \mu_H)\Lambda_H}{b^2\epsilon^2\beta_{VH}\beta_{HV}\Lambda_V(1 - \psi)\mu_H}$$

Figure 3.12 shows the normalized sensitivity indices of the reproduction number of the complete model with respect to the various parameters that it depends on. If we compare the vector control parameters, it can be seen that the reproduction number is most sensitive to changes in ϵ (representing reduction in sandfly bites due

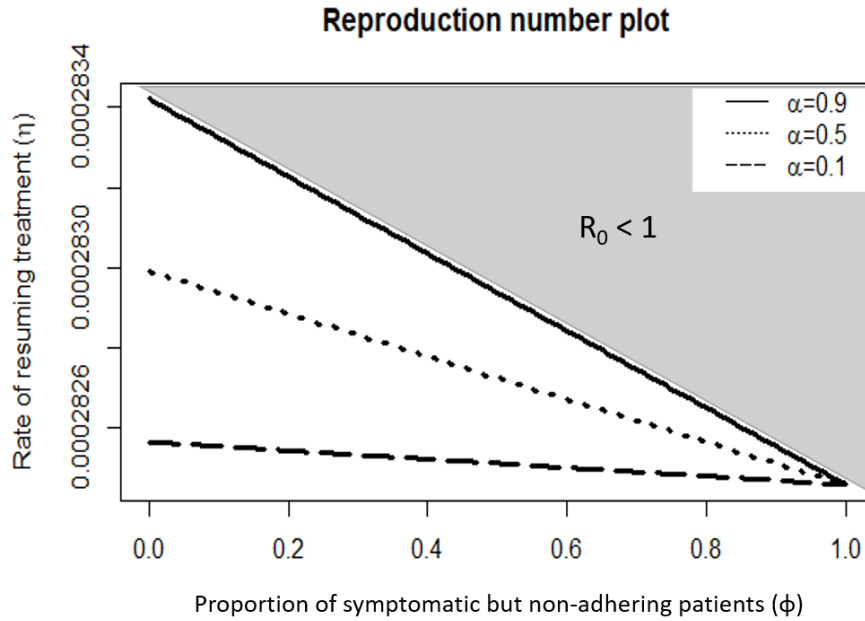

Figure 3.11: In Model II, relation between levels of non-adherence to treatment ($1 - \phi$) in population and rate of resuming treatment after non-adherence (η) for achieving $R_0 < 1$ for different levels of infectivity of the non-adherent patients (α).

to Long Lasting Insecticidal Nets) followed by ψ (Larval Source Management) and then δ_V (Indoor residual spraying).

Furthermore, to address the efficacy of the systematic Integrated Vector Management (IVM) program with the consideration of extra incidences due to the clinically resolved but infectious cases in combination with varied levels of adherence to the treatment is demonstrated in Figure 3.13. It can be seen that the effect of IVM on decreasing the endemic prevalence increases with increase in population's adherence to treatment. Notice that the effect of LSM is most improved due to an improved adherence to treatment.

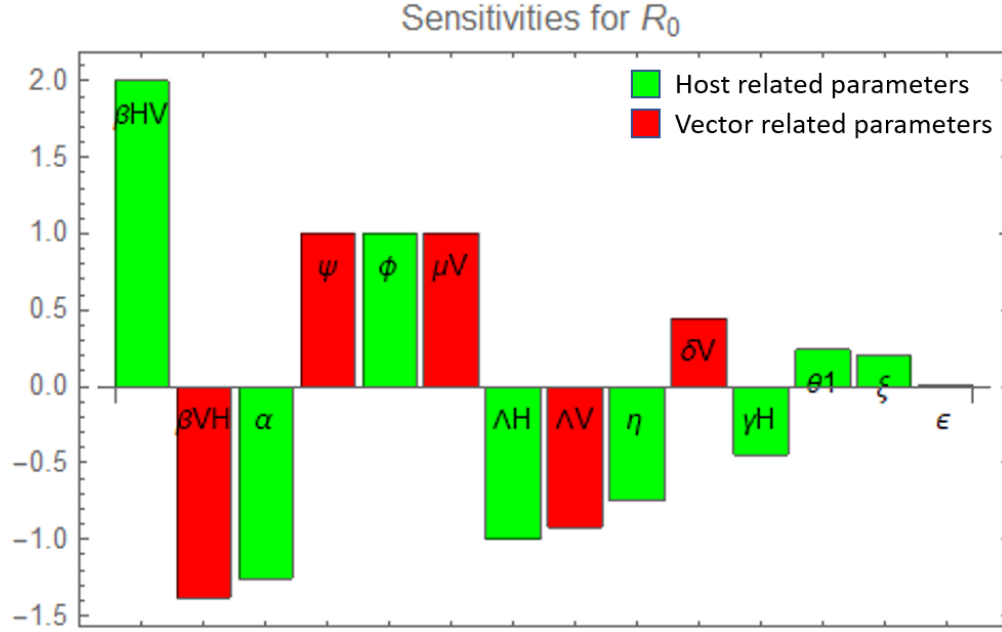

Figure 3.12: Normalized Sensitivity Indices for R_0 for Various Parameters in Model II.

Figure 3.14 shows how different parameters in the model namely treatment rate (γ_H), proportion of perfect adherence (Type I; ϕ), proportion of adherence to treatment after defaulting at least once (Type II; ξ) and rate of resuming or restarting the treatment after defaulting (η) respectively have effect on the prevalence of disease in humans ($\frac{I_H^*+V_H^*}{N_H}$). Since it could be seen that the dependence of ϕ on the prevalence is linear, while others non-linear, it is important to understand the effect of Type I and Type II adherence behaviors on the health-seeking behavior of the individuals as seen in Figure 3.5. This was seen under the assumption that the value of $R_0 > 1$ is 2.

Finally, to address the potential for elimination of VL from Bihar, India by 2020, Figure 3.15 uses the current population of Bihar as the susceptible humans out of which approximately 5000 are assumed to be infected currently. The figure depicts that given current vector control and level of adherence (solid red line), the disease is not eliminated by 2020. But it can be seen from the dashed lines in the plot that

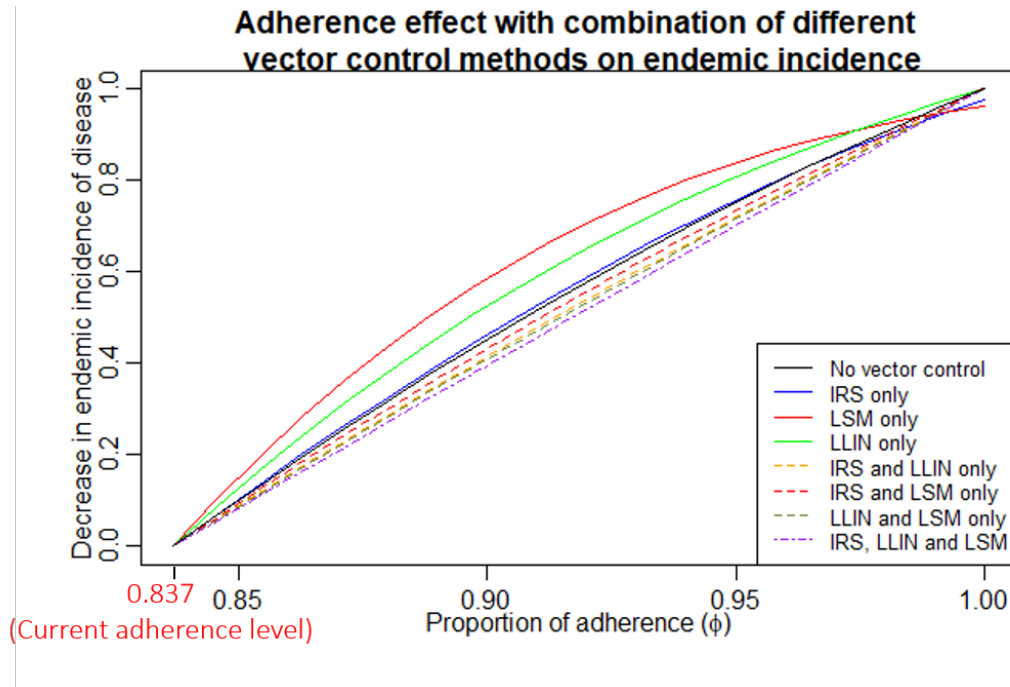

Figure 3.13: Effect of the combination of different vector control strategies with improved adherence on the proportion of change of disease prevalence in humans.

by improving adherence to the treatment in the population, the elimination target becomes achievable.

3.4 Discussion

Even if a Visceral Leishmaniasis endemic block successfully attains the incidence number of less than 1 case per 10,000 population, the elimination in the block is validated if the number is maintained under 1 for consecutive 3 years (43). To maintain the number of low incidence cases, it is necessary that potential reservoirs are spotted and addressed (44). Risk of non-adherence is high and Model II in this study provides a framework to incorporate the non-adherence to treatment in a more realistic way by assuming a gamma-distributed waiting time. This was inspired from the study that showed that the non-adherence is highest after around the first week

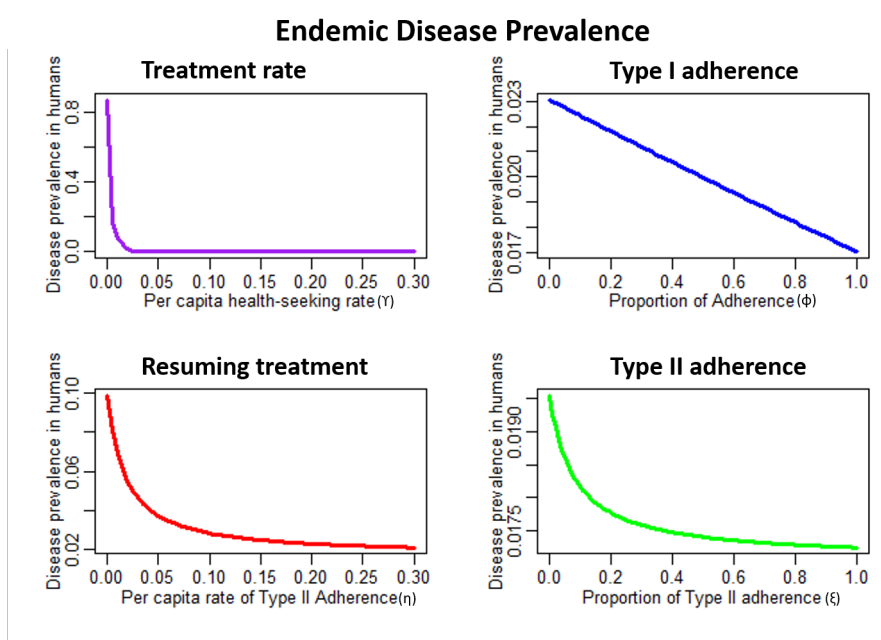

Figure 3.14: (Clockwise starting top-left) Effect of treatment rate (γ_H), proportion of perfect adherence i.e. completing the treatment exactly as prescribed in the first time (Type I; ϕ), proportion of adherence to treatment after defaulting at least once (ξ) and rate of resuming or restarting the treatment after defaulting ($1 - \eta$) respectively on the prevalence of disease in humans ($\frac{I_H^* + V_H^*}{N_H}$).

into the treatment (10) as shown in Figure 3.2. We could see the effect of increasing the waiting time of treatment non-adherers in treatment before defaulting increases the possibility of achieving elimination solely with treatment. This may be done with improved follow-up and surveillance.

Hirve et. al. (2016)(45) analyzed the disease transmission to conclude that the asymptomatic Leishmaniasis infection (ALI) contributed to 82% of the overall transmission. Also, they showed that there is as high as 90% under-reporting of ALI cases which act as potential reservoirs. Therefore, quantifying the infectiousness of the ALI cases or transmission from relapse and clinically recovered population becomes crucial

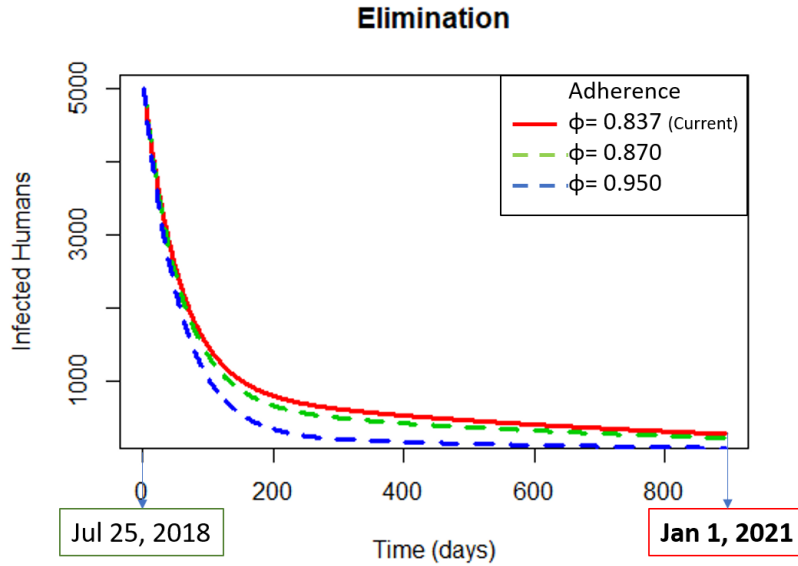

Figure 3.15: Feasibility of elimination of VL from Bihar, India by 2020 for different levels of adherence to treatment. This scenario incorporates the effects of current vector control strategies (Long Lasting Insecticidal Nets, Larval Source Management and Indoor Residual Spraying). It is assumed that non-adherent individuals (V_H) are 70% as likely to spread infection upon sandfly bite as the infected individuals before any treatment (I_H).

for designing strategies for elimination and its validation. Model II was constructed to address this.

Although 20% of Indian VL endemic regions continue to be highly endemic, India saw 75% reduction in VL cases within the first decade of the WHO elimination program (45). As we near the elimination, it is important to continue the controls long enough to reduce the chances of its resurgence (46). Even if elimination gets successfully achieved, sustaining it would be difficult without the availability of vaccines (47). In this context of nearing elimination and aim to sustain it, one may start to consider stochastic modeling to analyze the behavior of the system around the criti-

cal threshold (48), since the number of infectious individuals will be very small (49). This would consider the drastic reduction on the effect of controls leading to higher perturbations around the critical elimination threshold as shown in the series of papers (50; 51; 52) with an example of a host-vector model for mosquito-borne disease. Furthermore the use of the basic reproduction number (R_0) does not incorporate the rapid changes in current time, therefore, consideration of the mathematical results from this study can be redone in terms of the effective reproduction number which is $R_0 \times S(t)$ where $S(t)$ is the number of susceptible people at time t . However, DNDi stated that the decline in VL cases in India has not been regular (53). Also, in the light of high estimated underreporting of the cases (35) we may be sufficiently far from the critical elimination threshold to gain insights on dynamics and elimination potential of VL with treatment non-adherence through ODE systems.

From Figure 3.14, it can be seen that people who default from the treatment pose more risk by becoming hidden from the surveillance than the people who delay accessing the treatment. Therefore, there is a need to focus efforts on clinically recovered infecting defaulters. Seeking a balance in reducing delay in health-care access and improving overall adherence to treatment is crucial to the effectiveness of the current efforts. Using the empirical studies like (11), (10), (13) and others, it has been identified that main reasons for non-adherence are side-effects of treatment, cost of drugs, lack of faith in the health centers and illiteracy about the disease and treatment. Simultaneous efforts on addressing factors for behavioral issues and their effect is critical.

To upgrade the already existing sophisticated interventions directed towards eliminating Visceral Leishmaniasis from the South-east Asian region, it is important to identify the factors that are hindering the process, quantify the effects of different factors and prioritize them accordingly and then design a new protocol based on this

knowledge. A study (54) concludes the need for reinforcement of the integrated vector management methods. We have shown that the effect of improving adherence to the treatment varies for different combinations of the methods used (Figure 3.13) which may work as a guideline for the new protocols. The significance of the vector control strategies is also highlighted from their high sensitivity indices for the reproduction number, but it is noteworthy that other factors explored in this study play a crucial role in reducing the endemicity of VL. Assuming that the current efforts in vector controls programs is maximal, Figure 3.15 shows how improvement in adherence can be a field to input further efforts. This can be done by education and awareness and by tracking the follow-ups of the patients for treatment.

We also demonstrated a way to reduce the dimension of models while preserving the critical outcome measures and waiting times in treatment. Through the reduced structures, the Models I and II could be compared to see how different assumptions on treatment non-adherence behavior leads to different mechanisms. Therefore, it is important to base the mathematical models on region-specific causes of non-adherence.

The purpose of this study was to emphasize on the need for considering different subjective factors like *illness beliefs* and *treatment beliefs* which determine the adherence to the treatment (55). Additionally, significance of active detection of early asymptomatic cases, surveillance and reporting of cases of relapse and overall improvement of quality of life of the population in the endemic regions are needed to be explored in addition to the IVM interventions. This will ensure that the incidence is low in reality and not just on the reports so that a delayed surge of infection, if any, can be predicted beforehand. Note that, there is high spatial heterogeneity in the endemicity of VL in different sub-districts of Bihar (56). Different regions show present outcome of the same interventions implemented (35). Therefore, to achieve the goal of bringing the incidence below 1 per 10,000 people may need different ef-

forts in different regions. This may be addressed in future work by either getting region-specific parameters and even by meta-population model to consider movement of people between the regions.

The plots are capable of only qualitative description because the parameter values assumed are from literature and might not be in line with each other and with the current scenario but they suffice the purpose of identification of behavioral factors hindering the elimination process. Some parameter values had to be assumed between the range [0,1] due to the unavailability of the data of patients after starting the treatment in terms of after how many days a patients follows the treatment regularly, defaults from the treatment, resumes treatment after non-adherence etc. as well as for the infectiousness of the patients who have gone under incomplete treatment highlights the need for more studies and research and improved and publicly available records in these aspects.

REFERENCES

- [1] W. H. Organization, UNICEF, *et al.*, “Global vector control response 2017-2030,” 2017.
- [2] National Vector Borne Disease Control Programme: WHO country office for India, “Accelerated Plan for Kala-azar Elimination 2017,” http://www.who.int/leishmaniasis/resources/Accelerated-Plan-Kala-azar1-Feb2017_light.pdf?ua=1.
- [3] World Health Organization: Regional Office for South-East Asia, “Frequently Asked questions on Visceral leishmaniasis (kala-azar),” 2013. <http://apps.who.int/iris/bitstream/10665/205090/1/B5042.pdf?ua=1>.

- [4] A. B. Joshi, M. L. Das, S. Akhter, R. Chowdhury, D. Mondal, V. Kumar, P. Das, A. Kroeger, M. Boelaert, and M. Petzold, “Chemical and environmental vector control as a contribution to the elimination of visceral leishmaniasis on the indian subcontinent: cluster randomized controlled trials in bangladesh, india and nepal,” *BMC medicine*, vol. 7, no. 1, p. 54, 2009.
- [5] NVBDCP, “Manual on integrated vector management india,” 2015.
- [6] Picado A., Dash A. P., Bhattacharya S., Boelaert M., “Vector control interventions for visceral leishmaniasis elimination initiative in South Asia, 2005-2010,” *The Indian journal of medical research*, vol. 136, no. 1, p. 22, 2012.
- [7] Tedla Y. G. and Bautista L. E., “Drug Side Effect Symptoms and Adherence to Antihypertensive Medication,” 2015.
- [8] Bosworth H. B., “Enhancing medication adherence: The public health dilemma,” 2014.
- [9] Torrey T., “Reasons patients don’t comply with treatment recommendations,”
- [10] Kansal, S., Chakravarty, J., Kumar, A., Malaviya, P., Boelaert, M., Hasker, E., Ostin, B., Sundar, S., “Risk Factors associated with defaulting from visceral leishmaniasis treatment: analysis under routine programme conditions in Bihar, India,” *Tropical Medicine & International Health*, vol. 22, no. 8, pp. 1037–1042, 2017.
- [11] Mondal D., Singh S. P., Kumar N., Joshi A., Sundar S., Das P., Siddhivinayak H., Kroeger A., Boelaert M., “Visceral Leishmaniasis Elimination Programme in India, Bangladesh, and Nepal: Reshaping the Case Finding/Case Management Strategy,” *PLOS Neglected Tropical Diseases*, vol. 3, no. 1, pp. 1–8, 2009.

- [12] Lee H. J., Jang S. I., Park E. C., “Effect of adherence to antihypertensive medication on stroke incidence in patients with hypertension: a population-based retrospective cohort study,” *BMJ Open*, vol. 7, 2017.
- [13] Uranw S., Ostyn B., Dorlo T. P.C., Hasker E., Dujardin B., Dujardin J. C., Rijal S., Boelaert M., “Adherence to miltefosine treatment for visceral leishmaniasis under routine conditions in Nepal,” *Trop Med Int Health*, vol. 18, pp. 179–187, 2013.
- [14] S. S. Singh R. K., Pandey H. P., “Visceral leishmaniasis (kala-azar): challenges ahead,”
- [15] Smits H. L., “Prospects for the control of neglected tropical diseases by mass drug administration,” *Expert review of anti-infective therapy*, vol. 7, no. 1, pp. 37–56, 2009.
- [16] Singh O. P., Sundar S., “Developments in diagnosis of visceral leishmaniasis in the elimination era,” *Journal of parasitology research*, vol. 2015, 2015.
- [17] Shimozako H. J., Wu J., Massad E., “Mathematical modelling for Zoonotic Visceral Leishmaniasis dynamics: A new analysis considering updated parameters and notified human Brazilian data,” *Infectious Disease Modelling*, vol. 2, no. 2, pp. 143 – 160, 2017.
- [18] Singh V. P. and Ranjan A., Topno R. K., Verma R. B., Siddique N. A., Ravidas V. N., Kumar N., Pandey K., Das P., “Estimation of under-reporting of visceral leishmaniasis cases in Bihar, India,” *The American journal of tropical medicine and hygiene*, vol. 82, no. 1, pp. 9–11, 2010.

- [19] Gorahava K. K., Rosenberger J. M., Mubayi A., “Optimizing insecticide allocation strategies based on houses and livestock shelters for visceral leishmaniasis control in Bihar, India,” *The American journal of tropical medicine and hygiene*, vol. 93, no. 1, pp. 114–122, 2015.
- [20] K. Gorahava, “Optimization models for leishmaniasis control: A case for bihar, india,” 2013.
- [21] Gonzalez B., *Quantitative Modeling Methods For Analyzing Clinical To Public Health Problems*. Arizona State University, 2015.
- [22] C. Kribs-Zaleta, N. A. Siddiqui, N. Kumar, and P. Das, “The control reproduction number and case-underreporting of visceral leishmaniasis in bihar, india,” 2009.
- [23] Mubayi A., “Chapter 7 - Inferring Patterns, Dynamics, and Model-Based Metrics of Epidemiological Risks of Neglected Tropical Diseases,” in *Disease Modelling and Public Health, Part B* (R. C. R. Rao A. S. R. S., Pyne S., ed.), vol. 37 of *Handbook of Statistics*, pp. 155 – 183, Elsevier, 2017.
- [24] Morales D., Paredes M., Mubayi A., “Dynamics of Cutaneous Leishmaniasis Infection in the Presence of Bird Reservoirs as a Tool for Vector Surveillance in Ecuador,” 2016.
- [25] Singh S. P., Reddy D. C. S., Rai M., Sundar S., “Serious underreporting of visceral leishmaniasis through passive case reporting in Bihar, India,” *Tropical Medicine & International Health*, vol. 11, no. 6, pp. 899–905, 2006.
- [26] Chomel B., “Surveillance of Visceral Leishmaniasis,” *Consulta de expertos OPS/OMS sobre Leishmaniasis Visceral en las Américas*, p. 121.

- [27] Galatas B., Bassat Q., Mayor A., “Malaria Parasites in the Asymptomatic: Looking for the Hay in the Haystack,” *Trends in Parasitology*, vol. 32, no. 4, pp. 296 – 308, 2016.
- [28] Vermeire E., Hearnshaw H., Van Royen P. Denekens J., “Review Article: Patient adherence to treatment: three decades of research. A comprehensive review,” *Journal of Clinical Pharmacy and Therapeutics*, vol. 26, pp. 331–342, 2001.
- [29] Singh O. P., Hasker E., Boelaert M., Sundar S., “Elimination of visceral leishmaniasis on the Indian subcontinent,” *Lancet Infect Dis*, vol. 16, 2016.
- [30] Ostyn B., Hasker E., Dorlo T. P. C., Rijal S., Sundar S., Dujardin J.-C., Boelaert M., “Failure of Miltefosine Treatment for Visceral Leishmaniasis in Children and Men in South-East Asia,” *PLOS ONE*, vol. 9, pp. 1–8, 06 2014.
- [31] Medley G. F., Hollingsworth T. D., Olliaro P. L., Adams E. R., “Health-seeking behaviour, diagnostics and transmission dynamics in the control of visceral leishmaniasis in the Indian subcontinent.,” *Nature*, vol. 528, no. 7580, pp. S102–8, 2015.
- [32] S. DebRoy, O. Prosper, A. Mishoe, and A. Mubayi, “Challenges in modeling complexity of neglected tropical diseases: Assessment of visceral leishmaniasis dynamics in resource limited settings,” *arXiv preprint arXiv:1609.00788*, 2016.
- [33] M. O. Fofana, G. M. Knight, G. B. Gomez, R. G. White, and D. W. Dowdy, “Population-level impact of shorter-course regimens for tuberculosis: a model-based analysis,” *PloS one*, vol. 9, no. 5, 2014.

- [34] S. Mushayabasa and C. Bhunu, “Modeling the impact of early therapy for latent tuberculosis patients and its optimal control analysis,” *Journal of biological physics*, vol. 39, no. 4, pp. 723–747, 2013.
- [35] A. Mubayi, C. Castillo-Chavez, G. Chowell, C. Kribs-Zaleta, N. A. Siddiqui, N. Kumar, and P. Das, “Transmission dynamics and underreporting of kala-azar in the indian state of bihar,” *Journal of theoretical biology*, vol. 262, no. 1, pp. 177–185, 2010.
- [36] J. P. Boettcher, Y. Siwakoti, A. Milojkovic, N. A. Siddiqui, C. K. Gurung, S. Rijal, P. Das, A. Kroeger, and M. R. Banjara, “Visceral leishmaniasis diagnosis and reporting delays as an obstacle to timely response actions in nepal and india,” *BMC infectious diseases*, vol. 15, no. 1, p. 43, 2015.
- [37] O. Diekmann, J. Heesterbeek, and M. G. Roberts, “The construction of next-generation matrices for compartmental epidemic models,” *Journal of the Royal Society Interface*, vol. 7, no. 47, pp. 873–885, 2010.
- [38] P. Van den Driessche and J. Watmough, “Reproduction numbers and sub-threshold endemic equilibria for compartmental models of disease transmission,” *Mathematical biosciences*, vol. 180, no. 1-2, pp. 29–48, 2002.
- [39] ELmojtaba I. M., Mugisha J.Y.T., Hashim M. H. A., “Mathematical analysis of the dynamics of visceral leishmaniasis in the Sudan,” *Applied Mathematics and Computation*, vol. 217, no. 6, pp. 2567 – 2578, 2010.
- [40] Census Organization of India, “District census 2011,” 2015 (Accessed March 23, 2019).

- [41] S. Biswas, “Mathematical modeling of visceral leishmaniasis and control strategies,” *Chaos, Solitons & Fractals*, vol. 104, pp. 546–556, 2017.
- [42] Sundar S., Olliaro P. L., “Miltefosine in the treatment of leishmaniasis: clinical evidence for informed clinical risk management,” *Therapeutics and clinical risk management*, vol. 3, no. 5, p. 733, 2007.
- [43] World Health Organization, “Process of validation of elimination of kala-azar as a public health problem in South-East Asia,” *World Health Organization, Regional Office for South-East Asia, New Delhi, India*, pp. 1–39, 2016.
- [44] Singh S. P., Reddy D. C., Rai M., Sundar S., “Serious underreporting of Visceral Leishmaniasis through passive case reporting in Bihar, India,” *Trop Med Int Health*, vol. 11, no. 6, pp. 899–905, 2006.
- [45] Hirve S., Boelaert M., Matlashewski G., Mondal D., Arana B., Kroeger A., Olliaro P., “Transmission Dynamics of Visceral Leishmaniasis in the Indian Subcontinent – A Systematic Literature Review,” *PLoS Negl Trop Dis*, vol. 10, no. 8, 2016.
- [46] J. M. Cohen, D. L. Smith, C. Cotter, A. Ward, G. Yamey, O. J. Sabot, and B. Moonen, “Malaria resurgence: a systematic review and assessment of its causes,” *Malaria journal*, vol. 11, no. 1, p. 122, 2012.
- [47] A. X. Mo, J. Pesce, and B. F. Hall, “Visceral leishmaniasis control and elimination: is there a role for vaccines in achieving regional and global goals?,” *The American journal of tropical medicine and hygiene*, vol. 95, no. 3, pp. 514–521, 2016.

- [48] E. A. Le Rutte, L. A. Chapman, L. E. Coffeng, S. Jervis, E. C. Hasker, S. Dwivedi, M. Karthick, A. Das, T. Mahapatra, I. Chaudhuri, *et al.*, “Elimination of visceral leishmaniasis in the indian subcontinent: a comparison of predictions from three transmission models,” *Epidemics*, vol. 18, pp. 67–80, 2017.
- [49] L. J. Allen, “A primer on stochastic epidemic models: Formulation, numerical simulation, and analysis,” *Infectious Disease Modelling*, vol. 2, no. 2, pp. 128–142, 2017.
- [50] S. M. O’Regan and J. M. Drake, “Theory of early warning signals of disease emergence and leading indicators of elimination,” *Theoretical Ecology*, vol. 6, no. 3, pp. 333–357, 2013.
- [51] S. M. O’Regan, J. W. Lillie, and J. M. Drake, “Leading indicators of mosquito-borne disease elimination,” *Theoretical ecology*, vol. 9, no. 3, pp. 269–286, 2016.
- [52] S. M. O’Regan and D. L. Burton, “How stochasticity influences leading indicators of critical transitions,” *Bulletin of mathematical biology*, vol. 80, no. 6, pp. 1630–1654, 2018.
- [53] P. Das, J. Alvar, and B. Sharma, “Elimination of vl in the indian subcontinent – is it achievable?,” 2014.
- [54] Poché D. M., Poché R. M., Mukherjee S., Franckowiak G. A., Briley L. N., Somers D. J., Garlapati R. B., “Phlebotomine sandfly ecology on the Indian subcontinent: does village vegetation play a role in sandfly distribution in Bihar, India?,” *Medical and veterinary entomology*, vol. 31, no. 2, pp. 207–213, 2017.
- [55] Bucks R. S., Hawkins K., Skinner T. C., Horn S., Seddon P., Horne R., “Adherence to Treatment in Adolescents with Cystic Fibrosis: The Role of Illness

Perceptions and Treatment Beliefs,” *Journal of Pediatric Psychology*, vol. 34, no. 8, pp. 893–902, 2009.

- [56] S. Jervis, L. A. Chapman, S. Dwivedi, M. Karthick, A. Das, E. A. Le Rutte, O. Courtenay, G. F. Medley, I. Banerjee, T. Mahapatra, *et al.*, “Variations in visceral leishmaniasis burden, mortality and the pathway to care within bihar, india,” *Parasites & vectors*, vol. 10, no. 1, p. 601, 2017.

Chapter 4

RISK-STRUCTURED MASS DRUG ADMINISTRATION FOR THE CONTROL OF SOIL-TRANSMITTED HELMINTHIASIS IN GHANA

4.1 Introduction

4.1.1 *Epidemiology of soil-transmitted helminthiasis*

Globally, Soil-transmitted helminthiasis (STH), a neglected tropical disease, is considered one of the major public health problems. It is an infection with the helminthic parasites, *Ascaris lumbricoides*, *Trichuris trichiura*, and hookworm (*Ancylostoma duodenale* and *Necator americanus*), which are transmitted via contaminated soil, hence the name. STH had global prevalence of 12.14% in 2017 with a loss of 1.9 million DALYs (Disability-adjusted life years) (1). Although this disease mostly causes morbidity, around 3000 deaths are also attributed to STH worldwide (1). Roundworm affects about 1.1 million people worldwide; hookworm and whipworm affect between 740,000 to 800,000 worldwide (Centers for Disease Control and Prevention, 2013) with the highest prevalence in sub-Saharan Africa (2). Along with east Asia, hookworm prevalence is reportedly highest in sub-Saharan Africa (3). In Ghana, the 2017 prevalence of all STH was 14.25% (1) (see Figure 4.2 for species-wise prevalence) while the prevalence of hookworm in the middle belt was as high as 45% (4).

4.1.2 *Life cycle of STH*

Ingestion of helminths happens upon consumption of food that is contaminated by helminth worms or when hands or food with contaminated dirt are put in mouth

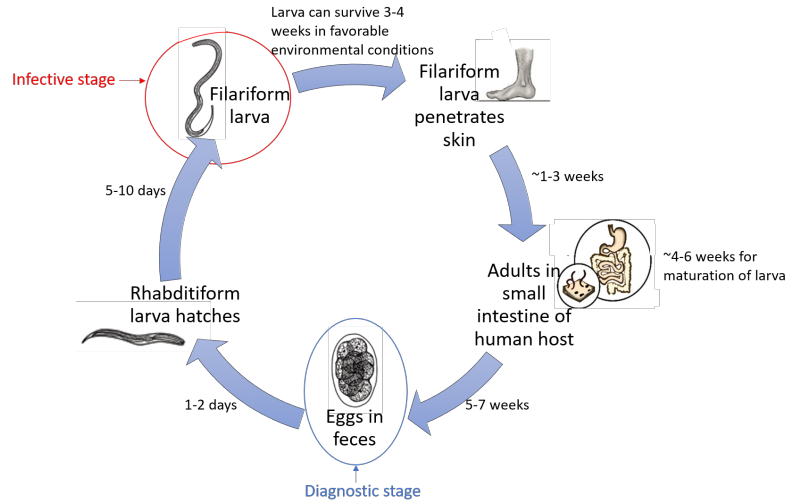

Figure 4.1: Life Cycle and Mode of Transmission of Helminths (Hookworm)(5; 7)

without washing (5). Roundworm and whipworm are transmitted by ingestion of worm eggs which then settle and grow in the intestines of humans. Hookworms (for example *Ancylostoma duodenale*) are transmitted by the penetration of filariform (a larvae form) through the skin and then enters the bloodstream to travel and mature in the small intestine. The *Ancylostoma* may also be transmitted through ingestion. The adult worms then release eggs into the soil (or environment) through improperly disposed human feces (6). As shown in Figure 4.1, the worms are infective only when they enter the human body (either by ingestion or by penetration through skin) in the filariform larva stage.

4.1.3 Risk factors of STH

People infected with STH or intestinal worms show symptoms such as diarrhea, general abdominal pains, weakness and in the case of hookworm, blood loss which can result in severe anemia. All three species of helminths thrive in warm and temperate regions and particularly in places where sanitation and hygiene are poor.

Environmental factors such as inaccessibility to safe drinking water, improperly cooked foods, limited or lack of toilets, lack of flowing water are examples of difficulties faced by millions of people in Ghana.

Immunological factors : Post preventive chemotherapy, the intensity of reinfection of STH in a host is higher. Dunn et. al. (2019) showed that the rounds of MDA should be frequent enough to prevent the reinfection of treated people (8).

Coinfection and co-circulation : Co-infection and co-circulation of all 3 types of STH are common in highly endemic regions (9). Additionally, the coinfection of STH (specially hookworm) and *Plasmodium* is also common in various countries, including Ghana (10; 11; 12).

At risk sub-populations: Various sub-populations can be considered to be at high-risk depending on spatial variation and infection distribution. These include children (due to high susceptibility to roundworm and whip worm and playing in dirt), farmers (working barefoot in the soil; (13) shows results for Ghana), pregnant women (since parasites may travel to mammary glands making vertical transmission of disease possible), parents (due to high exposure to contamination through sharing home and toilet environment with their children), and school workers (due to high exposure to contamination through sharing school surfaces and toilets with high density of children at least half of the day).

4.1.4 *Mass drug administration (MDA) for STH control in Ghana*

MDA is defined as the delivery of essential medicines as a preventive measure where populations or sub-populations are offered medicine irrespective of their health condition or individual diagnosis (15). MDA is essential for decreasing pathogen levels

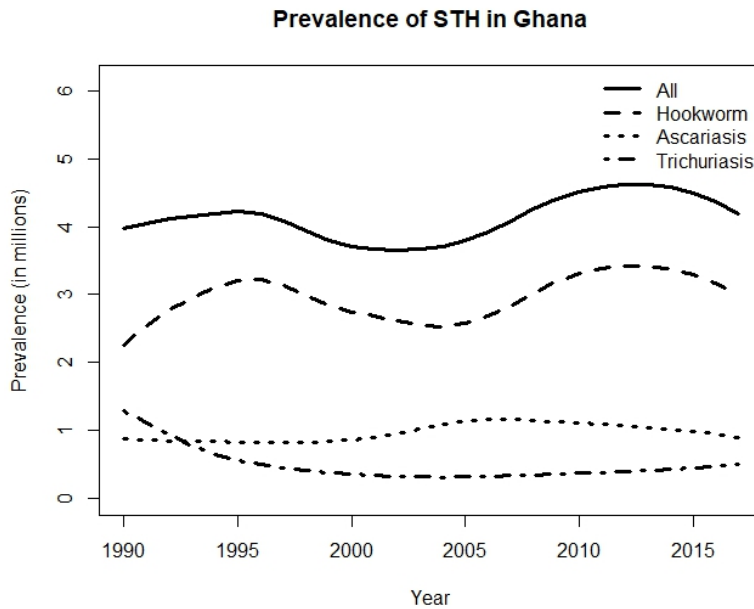

Figure 4.2: Prevalence of STH in Ghana for different helminth species. Data downloaded from (14).

in the population, reducing and interrupting the transmission of the disease, thereby controlling and eliminating NTDs like Lymphatic Filariasis, Trachoma, Onchocerciasis, Schistosomiasis and STH (16; 17).

In line with WHO’s guidelines on MDA, 7 million people in Ghana have been targeted for MDA (also called as preventive chemotherapy) through the use of albendazole or mebendazole - two drugs used against STH. MDA is a key strategy currently being used to control the spread of STH by Ghana’s Ministry of Health. Although MDA has been implemented in Ghana since 2000, this disease is still recurring among vulnerable populations, especially people in rural areas. Along with WASH (Water, Sanitation and Hygiene), school-based MDA is the main strategy used for control. WHO guidelines: treat 75% of SAC since intensity is highest. For hookworm other parts of the community (like pregnant women, miners, school work-

ers etc.) (18). Due to resource limitations and logistics to conduct community-wide MDA, researchers have been investigating the cost-effectiveness of community-wide preventive chemotherapy.

School-based (environments where STH is most likely to be transmitted) MDA, health education and awareness, use of clean water and the monitoring and evaluation of progress of MDA are some of the interventions used by the Ministry of Health in Ghana to curb the disease. The target group for MDA in Ghana is children, particularly school-aged children (5-14 years). Other age groups that are vulnerable to the disease are the pre-school aged children (0-4 years) and high-risk adults (\geq 15 years) but these age groups are not targeted in current MDA efforts (19). Although there are positive indicators leading to the gradual achievement of these goals for WASH programs (WASH and the Neglected Tropical Diseases, 2013), the 75% coverage target of MDA was not reached in Ghana in 2017 (20). Hookworm infection is common in children, the prevalence and infection intensity are highest in adults (21). This adult population more susceptible to hookworm infection is systematically missed due to the children-centric MDA.

4.1.5 Goal of the study

Lo et. al. (2015) carried out a study in Ivory Coast and showed that a community-wide treatment for STH is the most cost-effective when structured and implemented based on age groups. That is when both school-based MDA (for treating school children) and community-based MDA (for treating adults in the community). Since the cost of delivery for community-based MDA is high, its cost-effectiveness is debated. Therefore, we identify that the adults (school officials) at school are at higher risk of STH infection due to their activities among children (who are known for unhygienic behaviors) and hence exposed to higher contamination. The goal of this work is to

extend the prior work in Ivory Coast and identify the optimal age-structured coverage of MDA in the Ghanaian context. To achieve the goal, a transmission dynamics model for STH (focusing particularly on hookworm infection transmission) was used to capture infection levels for different coverages for MDA. The infection dynamic model was coupled with a cost model and various policies were evaluated based on the cost-effectiveness of strategies. The examination involved comparison of existing MDA Ghanaian policy (focusing only on children) with age and risk structured policies in which both adults and children are covered in systematic way under MDA implementation. The policies are evaluated under two broad categories, limited and unlimited available drug pills for MDA. Turner et. al. (2016) point out that the success of the community-wide treatment is highly dependent on the epidemiological setting and types of population groups (22). Hence, we further assessed the cost-effectiveness of school-based MDA that included treatment of high-risk adults along with children.

In summary, the study examines community-wide MDA by finding optimal coverage of MDA between adults and children in Ghana. In particular, we aim to focus on these research questions: (1) How does the dynamics of STH in Ghana change when different MDA coverages in children and adults are considered? (2) What are the optimal percentages of coverage between adults and children that could reduce prevalence of STH in Ghana below a target level in a specified time and are also cost-effective? (3) How do these optimal coverages differ if the MDA is covered based on risk groups, high-risk adults, and children population?

4.2 Methods

This section will introduce the readers briefly with the rich past of STH mathematical modeling. Then we will extend the previously used age-structured model to a

risk-structured model. Based on these models we develop a corresponding cost model with various scenarios of MDA coverages. Then we perform a cost-effectiveness analysis to compare the cost-effectiveness of current MDA policy in Ghana with respect to the most cost-effective community -based MDA policy and to the most cost-effective risk-structured school-based MDA policy.

4.2.1 *Summary of progression of STH modeling*

Truscott et. al. (2016) present a thorough review of different forms of mathematical models used in the past to capture STH transmission (23). Compartmental modeling to capture and understand dynamics of STH had been first done in 1979 with host, parasite and environment and three classes. Which was then transformed into modeling mean worm density (weighted average of worms per host) and environment due to the importance and non-uniform distribution of worm densities per host (24). Croll et. al. (1982) provided us with a data-driven formulation for the computation of prevalence from the mean worm density (25). To capture the distinct hosts' age profile of the distribution of worms, Anderson and May (1985) introduced us to a way to build an age-structure in hosts (26). Then to capture the effect of MDA on the worm density, a data driven functionality was given by Anderson and Medley (1985) (27). Since MDA comes with a massive cost, Medley et. al. (1993) introduced model-based cost-effectiveness analysis for cost per unit worm density reduced (28). Since then multiple cohort-based STH modeling studies have been done for various regions to compute the effectiveness of school-based and community based deworming to treat and prevent STH. One recent example is Lo et. al. (2015), who showed through a study for Ivory Coast that community-based MDA is more cost-effective than only school-based MDA (29) with their age-structure model based on Chan et. al. (1994) study (30). However, Medley and Hollingsworth (2015) wrote a

commentary indicating that the costs for community-based treatment may have been under-estimated. Coffeng et. al. (2015) have provided a simulation-modeling software WORMSIM (31) but obtaining all the parameter values for Ghana was not feasible to us. Our motivation was to identify the high-risk adults (based on exposure), MDA for whom will need a minimal additional cost as compared to school-based MDA for children only. We studied this using a compartmental modelling method.

4.2.2 Population-structuring

Mixing of populations : In this study, we considered two types of mixing patterns of the individuals in our modeling population: *homogeneous mixing* and *heterogeneous mixing*. *Homogeneous mixing* refers to the scenario where all adults mix or spend time equally with all the children in the population. *Heterogeneous mixing* scenario is only considered for adults and represents the situation where some class of adults, like teachers or school-workers, mix or spend time disproportionately more with the children as compared to the rest of the adults.

Age-structured categorization : Our modeled population is assumed to be divided into two groups based on age: Children (0 to 14 years) and Adults (15 years and above). This classification of age group is specially based on two relevant points for effective transmission of infection: (i) the hospitality of the host body for growth and reproduction of parasites and (ii) the level of contacts with contaminated environment. For example, higher likelihood of children playing bare-feet in the soil which may be contaminated, thus increasing susceptibility to infection.

Risk-structured categorization : In the *heterogeneous mixing* scenario, certain group of adults are assumed to spend more time with children, who are involved

with the unhygienic behavior which leads to high exposure to parasites from the environment. The teachers are considered to be part of this group which is referred to as high-risk adults since they are exposed to parasites on the surfaces of desks, chairs, doors etc. while sharing the same space with children. Hence, such a group is more likely to get the STH infection due to ingestion of these parasites.

4.2.3 Modeling framework

We use the widely used age-structured model for STH dynamics given in (32) with the reduction in mean worm density due to preventive chemotherapy as given in (33). Based on different combinations of coverages of MDA in children and adults, we compute the reduction on prevalence achieved and cost of MDA per year to perform incremental cost-effectiveness analysis, against the current policy of treating 75% children, to suggest the optimal coverage policy. Then we extend the age-structured dynamical model framework to differentiate between mean worm burden of high-risk and low-risk adult populations with preventive chemotherapy being administered to high-risk adults along with children in a school-based MDA setting. The summary of the two population structures used in the study are shown in Table 4.1. A similar cost-effectiveness analysis was performed to find optimal coverages in this new proposed setting. The structure of analysis is summarized in Figure 4.3.

Homogeneous Mixing of Adults with Children

Dynamical Model

Homogeneous mixing refers to the scenario where all adults mix or spend time equally with all the children in the population. Mean worm burden is the number of worms an individual host carries. The dynamics of worms in hosts (children and adults) and environment and how MDA reduces the mean worm burden in the system is shown

	Population Structures for Ghana	
	Age-structure	Risk-structure
Population categorization	<ul style="list-style-type: none"> • “Children” (ages 0-14 years) • “Adults” (ages 15 years and above). 	<ul style="list-style-type: none"> • “Children” (ages 0-14 years) • Adults (ages 15 years and above) <ul style="list-style-type: none"> - “High-risk” (school staff) - “Low-risk”
Assumptions in categorization	<ul style="list-style-type: none"> • Unhygienic children’s behavior and hence exposure to more contaminated environment. • Different worm aggregation distribution within a child and an adult. 	<ul style="list-style-type: none"> • Both adult risk groups will have same worm aggregation distribution • The exposure to contaminated environment of “High-risk” adults at school is higher due to much time spent with children in school

Table 4.1: Summary of population structuring used in the current work.

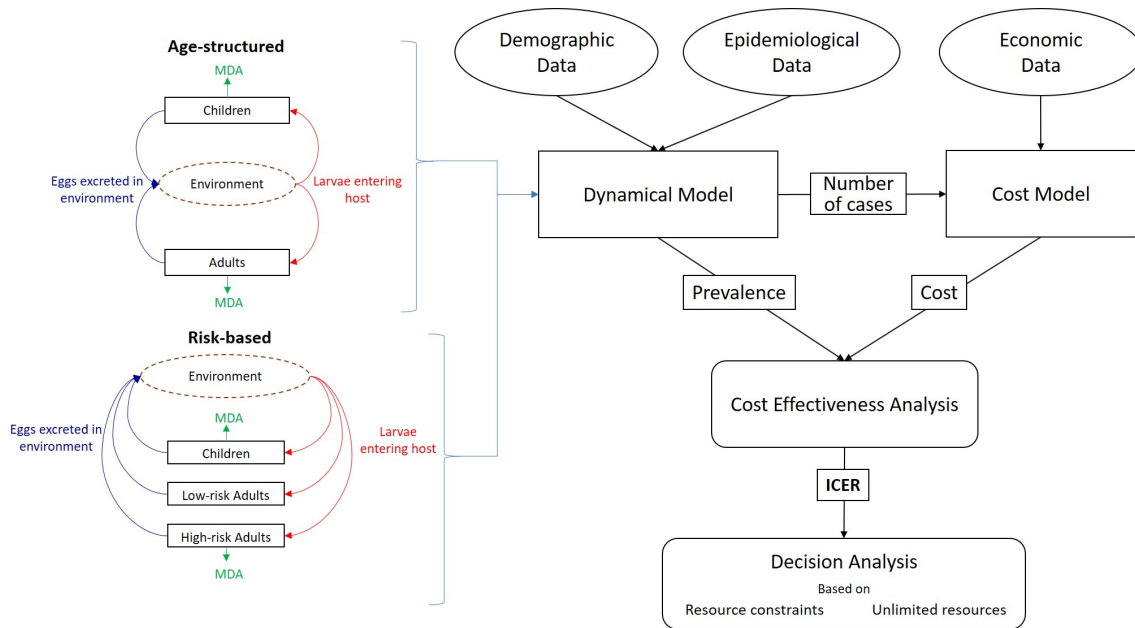

Figure 4.3: Flowchart of Analyses

in Figure 4.3. This is modeled using the following system (34)

$$\begin{aligned}\frac{dM_c}{dt} &= \beta_c l - \sigma M_c - \theta_c M_c \\ \frac{dM_a}{dt} &= \beta_a l - \sigma M_a - \theta_a M_a \\ \frac{dl}{dt} &= \psi z \lambda \bar{f}_1 - \mu l\end{aligned}$$

where M_c and M_a represent the mean worm burden in children and adult populations respectively and l is the average infection density (larvae) in the environment. $\beta_c l$ and $\beta_a l$ represent the uptake of larvae due to contact with the infection in the environment in children and adults respectively. σM_c and σM_a are the natural rates of excretion of worms from the host bodies. The reciprocal of μ is the average lifespan of larvae living outside the host body. $\theta_c (= -\log(1 - g_c h)/d)$ and $\theta_a (= -\log(1 - g_a h)/d)$ are the per capita rates of reduction of mean worm burden from children and adult populations respectively due to preventive chemotherapy, where h is the efficacy of the drug, g_c and g_a are the proportion of children and adult populations administered MDA per round and d is the interval between rounds of MDA. The addition of infective larvae in the environment at a rate ψ is a density-dependent process which incorporates the effect of $z (= e^{-\gamma};$ egg-production), λ (average eggs per female worm per gram of feces) and \bar{f} (average fecundity) given by the expression

$$\bar{f}_1 = f(M_c; k_c, z) n_c p + f(M_a; k_a, z) n_a (1 - p)$$

where n_c and n_a are children and adult population sizes respectively, p the fraction of egg output that enters the environment from children and f is the fecundity, the “measure of the number of off-spring produced by one organism over time” (Biology Dictionary, 2013), as a function of the mean worm burden (M), the negative binomial aggregation parameter k of the distribution of worms in different hosts and z as defined

above

$$f(M; k, z) = \frac{M}{\left(1 + \frac{M(1-z)}{k}\right)^{k+1}}$$

The basic reproduction number (R_0) is defined as the successful transfer and maturation of a worm in host upon reproduced by an adult worm in a host body and is given by the expression

$$R_0 = \frac{\psi z \lambda \bar{\beta}_1}{\sigma \mu}$$

where $\bar{\beta}_1$ is the weighted average of the contact rates β_c and β_a calculated as

$$\bar{\beta}_1 = \beta_c n_c p + \beta_a n_a (1 - p)$$

In this system we are only considering female worm population since only females are capable of reproduction. Using the mean worm burden from the dynamical system, the prevalence is calculated (34):

$$P(M; k) = 1 - \left(1 + \frac{M}{k}\right)^{-k}$$

As summarized along with other variables in the dynamical model in Table 4.2, $P_c = P(M_c; k_c)$ is the prevalence in children and $P_a = P(M_a; k_a)$ is the prevalence in adults. The number of infected individuals are then $I_c = P_c n_c$ in children and $I_a = P_a n_a$ in adults.

Using the expression of R_0 and assumption on quasi-stationary state of l (that is, the infective larvae in environment reach steady state earlier as compared to the worms in hosts), the dynamical system becomes

$$\frac{dM_c}{dt} = \beta_c l^* - \sigma M_c - \theta_c M_c \tag{4.1}$$

$$\frac{dM_a}{dt} = \beta_a l^* - \sigma M_a - \theta_a M_a \tag{4.2}$$

$$l^* = \frac{\sigma R_0 \bar{f}_1}{\beta} \tag{4.3}$$

Variables	Definitions
M_c	Mean worm burden in children
M_a	Mean worm burden in adults
M_l	Mean worm burden in low-risk adults
M_h	Mean worm burden in high-risk adults
P_0	Total disease prevalence before MDA
P_c	Disease prevalence in children
P_a	Disease prevalence in adults
P_l	Disease prevalence in low-risk adults
P_h	Disease prevalence in high-risk adults
I_0	Total number of infected individuals in absence of MDA
I_c	Number of infected children
I_a	Number of infected adults
I_l	Number of infected low-risk adults
I_h	Number of infected high-risk adults
$f(M; k, z)$	Fecundity of worms

Table 4.2: Variables Used in the Dynamical Models

Cost Model

According to the strategic plan of WHO for elimination of STH, the budget for MDA was divided based on the costs of components like health education, health-worker training, drug procurement, distribution and administration, transportation, supervision by health personnel, etc. (35). We built a cost model based on this information.

Given a coverage for MDA in the children ($g_c > 0$) and adult ($g_a > 0$) populations, the cost for administering preventive chemotherapy per individual is calculated using the broad categories of costs for drugs (treatment), human resources and delivery and administration (for example transportation) as follows:

Cost of implementing MDA in children is: $C_1 = C_H + C_C/g_c$

Cost of implementing MDA in adults is: $C_2 = C_H + C_A/g_a$

Here, C_H is broadly defined as cost of human resources i.e. wages of nurses, health-care workers who deliver MDA and supervision personnel; C_C and C_A are defined as the transportation costs incurred in school-based delivery and community-based delivery of MDA respectively per patient. Note that these costs (C_1 and C_2) are calculated only when there is at least some MDA coverage and hence are well-defined.

We assume that as the coverage is increased, the cost of transportation per patient decreases. Because of the effect of economies of scale which means that as the number of people treated increases, the cost per treatment decreases (36). This scale is done using the proportions g_c and g_a as shown above.

Therefore, the total cost of treating infected children and implementing MDA in children with g_c coverage is the sum of the cost of drugs needed to treat infected children accessing health-care and the cost of implementing MDA at a certain percentage

of coverage of the total population in children is calculated as

$$\tau_1 = C_D I_c + (C_D + C_1) g_c n_c$$

where C_D is the cost of drug per patient and the number of infected children (I_c) is obtained from the dynamical model above.

Similarly, the total cost of treating children and implementing MDA in adults with g_a coverage is the sum of the cost of drug needed to treat infected adults and the cost of implementing MDA at a certain percentage of coverage of the total population in adults.

$$\tau_2 = C_D I_a + (C_D + C_2) g_a n_a$$

where I_a the number of infected adults.

Therefore, the total cost of treating and implementing MDA strategically with g_c coverage in children and g_a coverage in adults is $T = \tau_1 + \tau_2$.

Average Cost-Effectiveness Ratio (ACER)

The Average Cost-Effectiveness Ratio (ACER) in this analysis is the difference in cost between existing policy (or no intervention) and a possible interventions, divided by the difference in their effect (37). ACER computation uses the outputs of the earlier two models: Dynamic model (Section 4.2.3) and Cost model (Section 4.2.3). ACER is calculated as the additional cost incurred against the averted prevalence:

$$ACER = \frac{T - \tau_0}{P_0 - P}$$

The numerator is the total increment in cost due to MDA and as the baseline, we use the costs for treatment of infected individuals (i.e. $\tau_0 = C_D I_0$) and no MDA; where $I_0 = P_0(n_c + n_a)$ is the total number of people infected in the absence of MDA.

The denominator represents the total benefit i.e. total decrements in the prevalence of STH in the population. The total prevalence is given by

$$P = \frac{I_c + I_a}{n_c + n_a}$$

and the baseline used, P_0 , is the prevalence of STH before MDA. The values of T and P are calculated for the endemic steady state in the dynamical model for the inferences to be made.

Scenario Analyses for Cost-effective MDA

The purpose of this work is to get an insight on the effects of different MDA strategies with age-structure so that STH can be controlled faster and more efficiently and still be cost-effective. As summarized in Table 4.3, the different strategies are

Scenario I : This is the baseline case in which there is no MDA at all. That is $g_c = g_a = 0$. The cost effectiveness of all the other strategies will be tested against this case.

Scenario II : To evaluate the current MDA strategy in Ghana, we examine the dynamics of change in prevalence when only children are (75% of coverage) targeted for MDA. This means that there is no coverage of adults in MDA so g_a is kept at 0.

Scenario III : This case includes implementation of MDA to adults along with the children. The assumption behind this strategy is that the resources are unlimited and hence it is possible to treat the whole population as one of the cases. Thus, this strategy is analyzed for all the combinations of coverages for children and adults in 0% to 100% for least ACER.

Scenario IV : In this case, to make the previous strategy more realistic we put a constraint on the number of individuals receiving MDA. Therefore, in this case too, the adults are also covered in MDA, but we fixed the total number of individuals treated to be equivalent to the number of individuals in MDA in the current policy (Scenario II) due to constraints on the number of pills for MDA. Thus, ensuring that the total number of individuals covered under MDA becomes $\tilde{n} = 0.75n_c$ individuals. The range of children covered in MDA (g_c) is from 0% to 75%, but the corresponding coverage in adults is calculated as

$$g_a = \frac{\tilde{n} - g_c n_c}{n_a}$$

To identify the most cost-effective strategy in each scenario, ACERs are calculated for every combination of coverages as given above for the numerically solved steady state prevalence and corresponding cost, we analyze the cases to obtain a "cost-effectiveness frontier" (37) which will become a tool for choosing the most cost-effective policy for a given budget.

Heterogeneous Mixing of Adults with Children

Heterogeneous mixing of adults with children may result in disproportionate risk of infection for adults. We broadly consider two types of cases, scenarios in which each adult experience same risk with children (Table 4.3; Section 4.2.3) and scenarios in which some adults (e.g., teachers and school workers; Scenario V) are at high-risk for acquiring infection as they spend more time with children. In the last case, we consider a separate class of adults, like teachers, who mix with children more than other adults as described under heading *Mixing of populations*.

Dynamical Model

For risk-based transmission dynamics of STH, after the assumptions on quasi-stationary state on the infection in environment as explained in Section 4.2.3, the dynamical model (Figure 4.3) becomes:

$$\frac{dM_c}{dt} = \frac{\beta_c \sigma R_0 \bar{f}_2}{\bar{\beta}_2} - \sigma M_c - \theta_c M_c \quad (4.4)$$

$$\frac{dM_l}{dt} = \frac{\beta_a \sigma R_0 \bar{f}_2}{\bar{\beta}_2} - \sigma M_l \quad (4.5)$$

$$\frac{dM_h}{dt} = \frac{\beta_c \sigma R_0 \bar{f}_2}{\bar{\beta}_2} - \sigma M_h - \theta_h M_h \quad (4.6)$$

Here, M_c , M_l and M_h are the mean worm burdens in children, low-risk adults and high-risk adults populations respectively. In this system, the mean worm burden of the high-risk adults (M_h) is dependent on the contact ratio (β_c) similar to the children since the high mixing is assumed to be in the schools while the fecundity is similar to the adults. Alternatively, the contact ratio can also be a weighted average of children's and adults' contact ratios. The average fecundity (\bar{f}_2) and average weighted contact ratio ($\bar{\beta}_2$) from all the three classes of population are

$$\bar{f}_2 = f(M_c; k_c, z_c)n_cp + f(M_l; k_a, z_a)n_lq + f(M_h; k_a, z_a)n_h(1 - p - q)$$

$$\bar{\beta}_2 = \beta_c n_cp + \beta_a n_lq + \beta_c n_h(1 - p - q)$$

where q is the proportion of infection contributed by the low-risk adults into the environment.

The reduction in mean worm burden due to MDA is at the per capita rate θ_c ($= -\log(1 - g_ch)/d$) in children population for g_c MDA coverage in children population (out of n_c) and at the per capita rate θ_h ($= -\log(1 - g_hh)/d$) in high-risk adult population (out of n_h). No low-risk adults will be covered under MDA, that is, no

community-wide treatment. To calculate the number n_h , we use Ghana's student-to-teacher ratio which was 32.83 in 2016 according to the United Nations Educational, Scientific, and Cultural Organization (UNESCO) Institute for Statistics.

Cost Model

Consequently, the updated structure of costs would be

$$C_1 = C_3 = C_H + C_D/g$$

where C_1 and C_3 are the costs of delivery of MDA per individual in the two groups: children and high-risk adults respectively. In this scenario, the reduction in cost of delivery was scaled by the total proportion of individuals under MDA given by the following relation

$$g = \frac{g_c n_c + g_h n_h}{n_c + n_h}$$

$g > 0$. Note that the cost of transport for high-risk adults is the same as children since they will also be given preventive chemotherapy at school. Therefore, the total costs per group are

$$\tau_1 = C_D I_c + (C_D + C_1) g_c n_c$$

$$\tau_l = C_D I_l$$

$$\tau_h = C_D I_h + (C_D + C_3) g_h n_h$$

where $n_h = n_c/32.83$ is the number of teachers in population, τ_1 , τ_l and τ_h are the total costs for MDA and treatment in children, low-risk adults and high-risk adults respectively, and, $I_c (= P_c n_c)$, $I_l (= P_l n_l)$ and $I_h (= P_h n_h)$ are the total number of infected children, low-risk adults and high-risk adults respectively calculated from the corresponding endemic prevalences from the dynamical model above using prevalence function described in Section 4.2.3.

Average Cost-Effectiveness Ratio

The corresponding ACER for this scenario is calculated using the same formula as in Section 4.2.3 but now by using total cost $T = \tau_1 + \tau_l + \tau_h$ and total prevalence

$$P = \frac{I_c + I_l + I_h}{n_c + n_l + n_h}$$

Strategies for MDA

Scenario V : The proposed strategy in this case will be that only children and high-risk adults will be covered under MDA. This is a more practical approach since the location of delivering MDA will be the same. From the current policy, the number of pills used in MDA is equivalent to covering \tilde{n} number of individuals. Thus, the proportion g_c , representing coverage level in children group, is varied in the range (0.0, 0.74] and the corresponding proportion of g_h , representing coverage level in high-risk group, is also the set of exact same values since we assume that the student-teacher ratio is fixed and constant. Hence, the relation $g_c n_c + g_h n_h \leq \tilde{n}$ always holds for this case.

Incremental Cost Effectiveness Ratio

The Incremental Cost-Effectiveness Ratio (ICER) is the difference in cost between two possible interventions, divided by the difference in their effect (in terms of reduction in prevalence) (37).

$$ICER_i = \frac{\tau_{i+1} - \tau_i}{P_{i+1} - P_i}$$

Here i is the index of the scenarios ordered in increasing order of cost. In this analysis, the identification of optimal coverage level in Ghana is carried out in two major steps: (i) the best strategy within each of the five scenarios is computed based on ACER, and (ii) the best strategy from each scenario is compared with best strategy from other

Scenario	Description	Coverage	
		Children	Adults
I: Baseline	No MDA	0	0
II: Current policy	MDA only to children	0.75	0
III: Assuming unlimited resources.	MDA to both children and adults.	(0,1]	(0,1]
IV: Constraint on number of individuals in MDA .	MDA to both children and adults; total number of individuals is fixed (\tilde{n}).	(0,0.75]	(0,0.5]
V: Constraint on number of individuals in MDA	MDA to children and high-risk adults; total number of individuals is fixed (\tilde{n})	(0,0.75]	(0,0.75] of high-risk adults

Table 4.3: Summary of age- and risk-based strategies for MDA in Ghana. Scenarios I through IV being age-structured and Scenario V being risk-based.

scenarios using ICER. Note, the best strategy for a scenario provides optimal coverage level based on age- or risk-structured populations under limited and unlimited budget constraints .

4.2.4 Parameter Estimates

The biological characteristics, distribution in hosts, drug efficacy and life-cycle of hookworms is different than the other two species of STH (*Ascariasis* and *Trichuriasis*). Therefore, using one model for all the helminthic worm dynamics is not ideal. We can see from Figure 4.2, and also from the sample studies in Ghana that the prevalence of hookworms is predominant as compared to *Ascariasis* and *Trichuriasis* (38; 39). Therefore, for the qualitative results, we are parameterizing the model specific to only hookworm infections.

Initial prevalence P_0 , before the MDA program in Ghana, is obtained from the hookworm infection prevalence in 2000 (year of initiation of STH control program). Therefore P_0 is 0.145 (1). The density-dependence coefficient z was calculated to be 0.93 for hookworm with $\gamma = 0.07$ (40). The life-span of adult hookworms is 3-4 years (33) therefore we assume σ is $1/3.5$ years⁻¹. Anderson et. al. (2013) review that the aggregation parameter for hookworm ranges from 0.33 to 0.61 (34). The parasite aggregation parameter in host for hookworms is shown to have a curvilinear relationship with the age (41). In that functional relation, it was seen that the aggregation parameter is higher in higher ages and more or less the same for ages 15 to 40 years. For ages between 0 to 14 years, it was seen that the value of the aggregation parameter increases somewhat linearly as age increases and we assume the value of that parameter for children to be a rough average in the range mentioned. From this knowledge, we choose the values $k_c = 0.47$ and $k_a = 0.61$.

Basic reproduction number (R_0) of 2.5 (range being 2-3 for hookworm infection (33)) is taken in order to be conservative in value estimation (42). The contact ratio of adults β_a (with reference as contact ratio of children $\beta_c = 1$) was obtained from the averages of the adults contact ratios for hookworm in the four communities studied in (29). All the parameter estimates are summarized in Table 4.4.

From a study on school-based deworming in Ghana, it was seen that 74.9% of the total MDA cost is attributed to personnel cost (human resources cost) such as per diem, allowance, fixed rate fees, refreshment and others (43). Transportation takes 16.6% of the cost and drug clearance and packaging needs 8.5%. Turner et. al. (2013) concluded that the estimated cost of annually once treatment was US Dollars (USD) 0.45 per person (44). Therefore we take the estimates of C_H to be 74.9% of 0.42 (excluding cost of drug per person), that is USD 0.31 per person approximately. The cost of delivering school-based MDA, C_C , will be 16.6% of 0.42, that is USD 0.07 per person approximately. C_A , cost of delivering community-based MDA, is approximately USD 0.21 assuming that it would cost 3 times the cost of school-based MDA (29) due to the logistical difficulties in community-wide treatment that may arise from traveling to different towns across Ghana. The estimates and sources for other cost model related variables is given in Table 4.5. The number of high-risk adults in the population (n_h) is calculated using the pupil-to-teacher ratio (32.83) in Ghana in 2016 according to the United Nations Educational, Scientific, and Cultural Organization (UNESCO) Institute for Statistics.

Begin of Table

Parameter	Definition	Value estm.	Source
β_c	Contact ratio of children with the infected environment	1.11	(23)
β_a	Contact ratio of adults with the infected environment	0.56	(23)
σ	Per capita mortality rate of hookworms in host body ($years^{-1}$)	1/3.5	(29)
R_0	Basic reproduction number	2.5	(42; 33)
k_c	Negative binomial dispersion parameter of infection in children	0.47	(29)
k_a	Negative binomial dispersion parameter of infection in adults	0.61	(29)
z	Egg density-dependent coefficient for hookworm	0.93	(40)
g_c	Proportion of MDA coverage in children	[0,1]	Varied for optimization
g_a	Proportion of MDA coverage in adults	[0,1]	Varied for optimization
g_h	Proportion of MDA coverage in high-risk adults	[0,1]	Varied for optimization

Continuation of Table 4.4			
Parameter	Definition	Value estimate	Source
h	Treatment efficacy for Albendazole against hookworm infections as the drug used in MDA	0.72	(45)
d	Interval between two rounds MDA (<i>years</i>)	1	(46)
p	Proportion of infection contributed by the children	2/3	(34)
q	Proportion of infection contributed by the low-risk adults	1/6	Assumed
n_c	Total population of children in Ghana	10452322	(47)
n_a	Total population of adults in Ghana	17046552	(47)
n_h	Total population of high-risk adults (teachers) in Ghana	$N_c/32.83$	UNESCO Institute for Statistics
n_l	Total population of low-risk adults in Ghana	$n_a - n_h$	Calculated as “non-high risk” adults

Table 4.4: Descriptions and Estimates of Parameters Used in the Dynamical Model.

End of Table

Variable	Quantities (per patient)	Value Estimate	Source
		(USD)	
C_D	Cost per unit drug: Al-bendazole (400 mg)	0.03	(46)
C_C	Cost of transportation for implementing MDA in children	0.07	(48)
C_A	Cost of transportation for implementing MDA in adults	0.21	Using the 3x multiplier effect from Lo et. al 2015 (29)
C_H	Cost of human resources	0.31	(44)

Table 4.5: Variable Definitions and Estimates for the Cost Model

4.3 Results

4.3.1 Average Cost Effectiveness Ratio

Homogeneous Mixing of Adults with Children

Scenario I : The prevalence of hookworm infection cases when there is no MDA, P_0 , is obtained from (14). The corresponding cost incurred in treating the infected population was calculated as $\tau_0 = C_D I_0$ where $I_0 = P_0(n_c + n_a)$. This formula assumes that everyone infected would seek and get treatment. These values served as the baseline values for ACER for all potential strategies. Without MDA, the prevalence clearly grows drastically as seen in Figure 4.5.

Scenario II : From Figure 4.5, it can be seen that the current policy in Ghana of treating 75% of the children with school-based MDA, it is possible to bring the prevalence down by a little but only temporarily and that it might not be sustainable. Thus, we see that this policy would not be effective enough in the long-run and it would be almost impossible to reach a point where prevalence is below 1% like WHO aims for. And therefore, we set up the Scenarios III and IV to address this problem.

Scenario III : With the assumption of no constraints on the number of pills available for MDA, we tested for every possible combination of coverages in children and adults. Using the steady state prevalences from the simulated dynamical system, we calculate the ACER as described in the previous section. From ACER solely, it was seen that administering 74% and 43% of children and adults respectively gave minimum ACER and thus is the best strategy within this scenario. The prevalence of hookworm infection reduced dramatically (Figure 4.5) with this strategy but this effect comes with higher cost.

Scenario IV : When the number of individuals covered in MDA is fixed, that is when $g_c n_c + g_a n_a = \tilde{n}$, a curvilinear relation between coverage and ACER was seen such that 54% and 16% MDA coverage in children and adult population had the lowest ACER.

4.3.2 *Heterogeneous Mixing of High-risk Adults with Children*

Scenario V : When heterogeneous mixing in populations is considered, we split the adult population into low-risk and high-risk based on the likelihood of them mixing with children. This case assumes constraints on the number of pills available for MDA. In our model we consider that total number of pills available (for proposed MDA

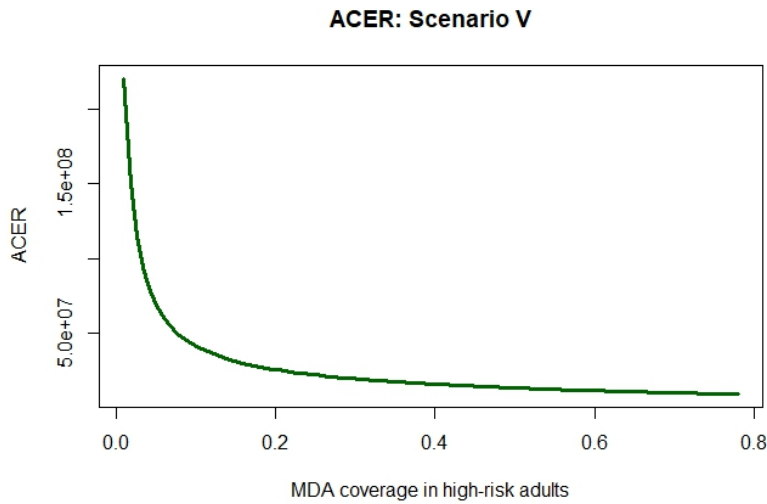

Figure 4.4: ACER for Different Coverages of Children and High-Risk Adults in MDA policy) are equal to the number of individuals that can be covered under the current policy of the Ghana government (that is a fixed number of school-aged children). As compared to the Scenario II (current policy) and best strategy from Scenario IV, risk-based administration of preventive chemotherapy did a better job at reducing prevalence (Figure 4.5). The ACER was minimum for the maximum coverage possible in this Scenario. Thus, the best strategy would be to achieve 74% children and 74% high-risk adults. Nevertheless, notice from the Figure 4.4, the ACER would have been low even for lower coverages but not the prevalence as much so.

4.3.3 Incremental Cost Effectiveness Ratio

Among the 5 policies obtained from the ACER analysis for each scenario, we perform ICER analysis to compare between the scenarios to shed light on which setup is comparatively more cost-effective. Refer to the Table 4.6 for the summary of policies in comparison.

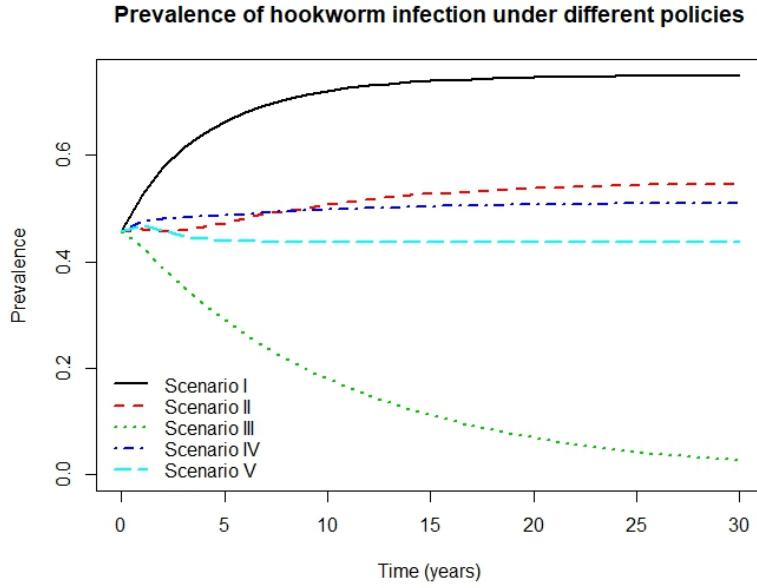

Figure 4.5: Comparison of effect of best strategies (based on ACER) with each of the Scenarios II (current policy; $g_c = 0.75, g_a = 0.00$), IV (age-structured MDA with constraints; $g_c = 0.56, g_a = 0.147$) and V (risk-based MDA with constraints; $g_c = 0.74, g_h = 0.74$). Scenario IV was not compared since it does not have any constraints and hence is not a feasible policy.

Find the results of ICER considering all strategies in all scenarios together, that is the cost-effectiveness plane and cost-effective frontier, in Appendix E.

Remark : All the simulations were performed in R version 3.4.3. The initial condition on the total mean worm burden for numerically solving the system was taken such that the relation

$$P_0 = 1 - \left(1 + \frac{M_0(1-z)}{k}\right)^{-k}$$

holds.

Scenario	Label strategy	g_c	g_a	g_h	Endemic Prevalence	Cost per year (In million USD)	ACER (In million USD)
I	A	0.00	0.00	0.00	0.7497	0.62	(Baseline)
II	B	0.75	0.00	–	0.5468	4.03	16.80
III	C	0.74	0.43	–	0.0277	9.44	12.21
IV	D	0.54	0.16	–	0.6066	7.58	48.64
V	E	0.74	–	0.74	0.4122	3.84	9.56

Table 4.6: Summary of ACERs (average cost effectiveness ratios) for the best strategies in each scenario as compared to no MDA (Scenario I). Here g_c , g_a and g_h are the MDA coverages in children, adults and only high-risk adult populations.

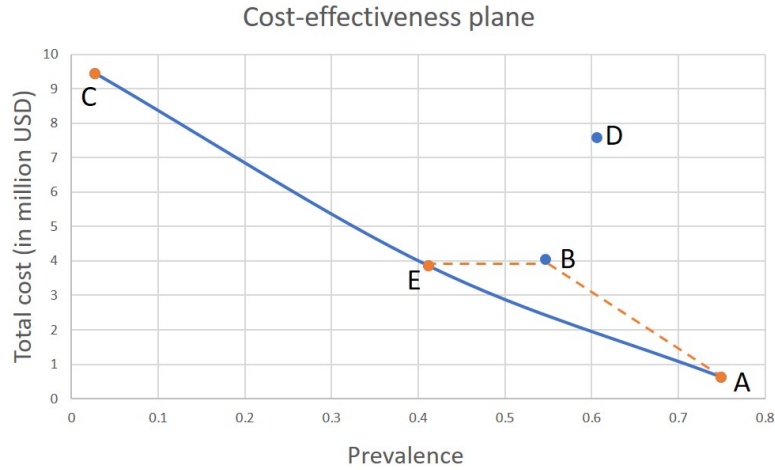

Figure 4.6: Graphical illustration of the cost-effectiveness frontier (orange line) and how the different strategies compare.

First, we sort the 5 strategies (*A* through *E* as shown in Table 4.6) in increasing order of their cost and then compute the ICER for the consecutive strategies as shown in Table 4.7. And exclude the strongly dominated strategies. After exclusion of dominated alternatives, we will obtain a cost-effectiveness frontier with strategies *A* (baseline), *E* and *C*, in order as shown in the graphic illustration in Figure ??.

Strategy	Prevalence	Total cost	Incremental cost (in USD)	Incremental benefit (Reduction in prevalence)	ICER (in million USD)
A	0.7497	618458	–	–	–
E	0.4122	3843676	3225218	0.3375	9.56
B	0.5468	4025806	182130	-0.1346	Dominated
D	0.6066	7575927	3550121	-0.0598	Dominated
C	0.0277	9436154	1860227	0.5789	3.21

Table 4.7: Calculating incremental cost-effectiveness and identifying dominated alternatives

4.4 Discussion

STH is a major health problem in Ghana. Hookworm infection causes intestinal hemorrhage leading to anemia (3). Although the global prevalence of STH is decreasing, the prevalence in Ghana is not as effectively (1). MDA is Ghana's primary control policy. The recommended coverage for MDA after a test for residual prevalence of MDA is greater than 75% in the population (49) and since the focus of MDA is only on school-age children, the recommended level of MDA has not been able to achieve and hence STH has been persisting at high level in Ghana. In this study we examined what percentages of coverage in adults and children would reduce prevalence with the given constraints on the number of pills available. Additionally, we examined whether it is indeed cost-effective to conduct community-wide MDA that targets both adults and children as suggested by Lo et. al. (2015) within the Ghanaian context. Furthermore, we also evaluated the impact of policy, implementing MDA in high-risk adults (those that spend more time with children) rather than focusing on adult individuals at random, on the prevalence of STH in Ghana.

MDA is provenly crucial to control the neglected tropical disease STH. We use dynamics models and data from Ghana to address our research questions under different age-structured, risk-based and pill-constrained scenarios. Scenario I captures the logistics when there is no MDA. In Scenario II when only 75% children are targeted, the prevalence seems to decrease temporarily to then increase beyond the initial level. Children will still get re-infected with the disease due to poor environmental conditions and due to transmission from pregnant women to their newborns. Infection and reinfection become cyclical. It was also seen that prevalence over time stabilizes at a value which is "not of public health significance" by WHO standards. Therefore, in the long run, eradication in the total population would be almost impossible when

only children are targeted for mass drug administration. This emphasizes on the need for investigation of new strategies.

When adults are included in MDA, we find that targeting approximately 43% of adults and 74% of children seem to be the most cost-effective on an average (Scenario III). This is in line with the conclusion of Lo et. al. (2015) for Ivory Coast. However this large coverage, even if it gets us more effect per dollar spent, demands a huge budget highly impractical for a developing country. So, for implementation of more practical policies we decided to analyze only a subset of it such that the number of individuals in MDA is fixed and finite. And that fixed number of individuals would be equal to 75% of children in Ghana (\tilde{n}). This condition would make sure that the number of pills available for MDA is equivalent to the one needed in the current policy. Thus in Scenario IV based on ACER, the cost incurred against extra cases avoided as compared to no MDA, the best strategy is considering 16% adults and 54% children under MDA (50).

Lastly, a model for heterogeneous mixing of adults with children was developed and a scenario based on this model was analyzed. This scenario (Scenario V) is studied because there is a high interaction of a particular group of adults, like teachers, who are exposed more to the wormy environment due to mixing disproportionately more with children rather than adults who interact or share space with only at most the children who are their kids. In Scenario V, we found that if the number of individuals under MDA has to be limited, 74% children and 74% high-risk adults need to be covered to achieve drastic reduction in prevalence of STH which is most cost-effective in comparison with no MDA.

Once we obtained the most cost-effective strategy within each scenario (based on ACER as compared to no MDA), we moved on to comparing between scenarios. Upon incremental cost-effectiveness analysis, we conclude that risk-based MDA im-

plementation strategy and a combination of children and adult populations in MDA coverage lie on the cost-frontier plane, the former being cheaper. Thus, alternative implementations of preventive chemotherapy based on these setups should be considered. Figure E.1) represents that the current policy does not lie on the cost-effective frontier. But similar is the case for pill-constrained age-structured MDA. The outcome does not change even if the risk-based policies are analyzed separately. We conclude that the risk-based MDA should be considered and evaluated for implementation. If the age-structured policies are to be implemented, the availability of pills should be increased for the implementation to be cost-effective.

Notice that, the total high-risk adults considered in this study amount to only about 1.9% of the total adult population, yet it does a better job at reducing the hookworm prevalence per dollar spent in school-based MDA. Thus, it would be important to assess the dependence of this outcome on the relative infectivity coefficient of the high-risk adults compared with that of the others. We can also consider identifying other high-risk adult groups (examples in the Introduction section): even if small in number, if they are clustered so that delivery of MDA is less costly than a community-based MDA, then treating them may improve the situation in surprising ways.

We report some limitations of our models and results. Even though we estimate the proportions of coverage for the most cost-effective policy, we would like to remark that these results are based on the dynamical model parameterized for hookworm transmission only. Although pregnant women are also provided MDA for hookworm, our study considers the current policy to be only school-based deworming. We assume that the average values for adults are overall averages including the pregnant women sub-population. It is noted that the results for prevalence change may depend on parameters such as the contact rates between different groups in a population and

the total MDA implementation cost, which depends on individual costs of human resources and delivery specific to the region of focus. The frequency of MDA rounds per year varies across geographic locations in Ghana based on the intensity of the disease. Also, Mupfasoni et. al. (2019) have shown that an optimal frequency of MDA can reduce the drug needs by 36% (51). The anti-helminthic treatment required can be estimated from the quantification of the worm load in the host (52; 24). Due to lack of some epidemiological data from Ghana, some parameter estimates may not be precise. The assumption that all school-age children attend school is also not completely realistic. Furthermore, this study focused on the costs incurred and prevalence reduced annually after an equilibrium has reached; the costs incurred over time also need to be collected to get a better validation of the cumulative efforts to control the disease. In spite of some of these limitations, this study provides the first estimate of MDA's cost-effective strategies and coverage levels for the STH in Ghana when high-risk targets are considered.

In conclusion, implementing MDA in only children to reduce the disease prevalence to levels of no public significance may not be possible. However, implementing MDA in at least some proportion of adults reduces prevalence faster and effectively. There might be some challenges in randomly finding and delivering MDA to adults for MDA. Also, community-wide MDA was found to be cost-effective only if there was no constraint. Hence, it will be more feasible and cost-effective to focus on high-risk adults who can be more approachable through existing delivery mechanisms of MDA such as school teachers or workers. In addition, reduction in morbidity to a level of no public health significance as aimed by the Ministry of Health could be achieved by systematically focusing on both adult and children groups rather than focusing on only one of the groups.

This work also gives insight on the need for measurement of Ghana-specific parameters to get more realistic estimates of the combination of the coverages that can significantly bring the disease prevalence down. Our models assumed that there is a cost associated with Albendazole drug used in MDA rather than it being donated to public health department, the cost of community-based MDA targeted to adults is 3 times the cost of school-based MDA, the cost of implementation is the sum of the cost of only human resources and transportation are incurred and the cost of implementing MDA per patient in both groups decreases as coverage is increased. The assumptions may be varied to study uncertainty in the model implications.

Using the mathematical model given by Silva and Hall (2010) to compute the average prevalence of STH based on the three separate species (53), the results of this study can be extended to get a more complete picture. The framework of this research study is important because it sheds lights on the use of mathematical models as tools that are critical in understanding the impact of health services such as MDA and predicting outcomes. Additionally, this study suggests that community-wide MDA at optimal percentage of coverage with consideration of the above-mentioned case setups is imperative in the reduction of prevalence of STH in Ghana. Researches on cost analysis to understand incremental utility and benefits are needed in Ghana in order to better understand the policies and actions that underpins Ghana's health structure.

REFERENCES

- [1] World Bank: Institute for Health Metrics and Evaluation, "Global health data exchange," Accessed: March 16, 2019. <http://ghdx.healthdata.org/gbd-results-tool>.

- [2] P. Hotez, “Hookworm and poverty,” *J Annals of the New York Academy of Sciences*, vol. 1136, no. 1, pp. 38–44, 2008.
- [3] P. J. Hotez, J. Bethony, M. E. Bottazzi, S. Brooker, and P. Buss, “Hookworm: “the great infection of mankind”,” *PLoS medicine*, vol. 2, no. 3, p. e67, 2005.
- [4] D. Adu-Gyasi, K. P. Asante, M. T. Frempong, D. K. Gyasi, L. F. Iddrisu, L. Ankrah, D. Dosoo, E. Adeniji, O. Agyei, and S. Gyaase, “Epidemiology of soil transmitted Helminth infections in the middle-belt of Ghana, Africa,” *J Parasite Epidemiology Control*, vol. 3, no. 3, 2018.
- [5] “Parasites- Hookworm,” 2013. <https://www.cdc.gov/parasites/hookworm/index.html>.
- [6] “Soil-transmitted helminths infection,” 2017.
- [7] A. Loukas, P. J. Hotez, D. Diemert, M. Yazdanbakhsh, J. S. McCarthy, R. Correa-Oliveira, J. Croese, and J. M. Bethony, “Hookworm infection,” *J Nature Reviews Disease Primers*, vol. 2, p. 16088, 2016.
- [8] J. C. Dunn, A. A. Bettis, N. Y. Wyine, A. M. M. Lwin, A. Tun, N. S. Maung, and R. M. Anderson, “Soil-transmitted helminth reinfection four and six months after mass drug administration: results from the delta region of myanmar,” *PLoS neglected tropical diseases*, vol. 13, no. 2, p. e0006591, 2019.
- [9] H. C. Lepper, J. M. Prada, E. L. Davis, S. A. Gunawardena, and T. D. Hollingsworth, “Complex interactions in soil-transmitted helminth co-infections from a cross-sectional study in sri lanka,” *Transactions of The Royal Society of Tropical Medicine and Hygiene*, vol. 112, no. 8, pp. 397–404, 2018.

- [10] R. B. Yapi, E. Hürlimann, C. A. Houngbedji, P. B. Ndri, K. D. Silue, G. Soro, F. N. Kouame, P. Vounatsou, T. Fürst, E. K. N’Goran, *et al.*, “Infection and co-infection with helminths and plasmodium among school children in côte d’ivoire: results from a national cross-sectional survey,” *PLoS neglected tropical diseases*, vol. 8, no. 6, 2014.
- [11] S. Kepha, F. Nuwaha, B. Nikolay, P. Gichuki, T. Edwards, E. Allen, S. M. Njenga, C. S. Mwandawiro, and S. J. Brooker, “Epidemiology of coinfection with soil transmitted helminths and plasmodium falciparum among school children in bumula district in western kenya,” *Parasites & vectors*, vol. 8, no. 1, p. 314, 2015.
- [12] P. J. Hotez, N.-K. Biritwum, A. Fenwick, D. H. Molyneux, and J. D. Sachs, “Ghana: Accelerating neglected tropical disease control in a setting of economic development,” *PLoS neglected tropical diseases*, vol. 13, no. 1, 2019.
- [13] D. Humphries, E. Mosites, J. Otchere, W. A. Twum, L. Woo, H. Jones-Sanpei, L. M. Harrison, R. D. Bungiro, B. Benham-Pyle, L. Bimi, *et al.*, “Epidemiology of hookworm infection in kintampo north municipality, ghana: patterns of malaria coinfection, anemia, and albendazole treatment failure,” *The American journal of tropical medicine and hygiene*, vol. 84, no. 5, pp. 792–800, 2011.
- [14] Global Burden of Disease Collaborative Network, Seattle, United States: Institute for Health Metrics and Evaluation (IHME), “Global burden of disease study 2017 (gbd 2017) results,” 2018; Accessed March 16, 2019. <http://ghdx.healthdata.org/gbd-results-tool>.
- [15] J. P. Webster, D. H. Molyneux, P. J. Hotez, and A. Fenwick, “The contribution of mass drug administration to global health: past, present and future,” *J Phil. Trans. R. Soc. B*, vol. 369, no. 1645, p. 20130434, 2014.

- [16] J. D. Keenan, P. J. Hotez, A. Amza, N. E. Stoller, B. D. Gaynor, T. C. Porco, and T. M. Lietman, “Elimination and eradication of neglected tropical diseases with mass drug administrations: a survey of experts,” *J PLoS neglected tropical diseases*, vol. 7, no. 12, p. e2562, 2013.
- [17] S. H. Farrell, J. E. Truscott, and R. M. Anderson, “The importance of patient compliance in repeated rounds of mass drug administration (MDA) for the elimination of intestinal helminth transmission,” *J Parasites vectors*, vol. 10, no. 1, p. 291, 2017.
- [18] P. J. Hotez, S. Brooker, J. M. Bethony, M. E. Bottazzi, A. Loukas, and S. Xiao, “Hookworm infection,” *J New England Journal of Medicine*, vol. 351, no. 8, pp. 799–807, 2004.
- [19] World Health Organization, “Ghana Neglected Tropical Disease Masterplan 2013-2017,” tech. rep., 2013.
- [20] O. mondiale de la Santé, W. H. Organization, *et al.*, “Schistosomiasis and soil-transmitted helminthiasis: number of people treated in 2017,” *Weekly Epidemiological Record= Relevé épidémiologique hebdomadaire*, vol. 93, no. 50, pp. 681–692, 2018.
- [21] P. M. Jourdan, P. H. L. Lamberton, A. Fenwick, and D. G. Addiss, “Soil-transmitted helminth infections,” *J The Lancet*, vol. 391, no. 10117, pp. 252–265, 2018.
- [22] H. C. Turner, J. E. Truscott, and R. M. Anderson, “Cost-effectiveness of community-wide treatment for helminthiasis,” *The Lancet Global Health*, vol. 4, no. 3, p. e156, 2016.

- [23] J. E. Truscott, H. C. Turner, S. H. Farrell, and R. M. Anderson, “Soil-transmitted helminths: mathematical models of transmission, the impact of mass drug administration and transmission elimination criteria,” in *Advances in parasitology*, vol. 94, pp. 133–198, Elsevier, 2016.
- [24] R. M. May and R. M. Anderson, “Population biology of infectious diseases: Part ii,” *Nature*, vol. 280, no. 5722, p. 455, 1979.
- [25] N. Croll, R. Anderson, T. Gyorkos, and E. Ghadirian, “The population biology and control of ascaris lumbricoides in a rural community in iran,” *Transactions of the Royal Society of Tropical Medicine and Hygiene*, vol. 76, no. 2, pp. 187–197, 1982.
- [26] R. Anderson and R. May, “Herd immunity to helminth infection and implications for parasite control,” *Nature*, vol. 315, no. 6019, pp. 493–496, 1985.
- [27] R. Anderson and G. Medley, “Community control of helminth infections of man by mass and selective chemotherapy,” *Parasitology*, vol. 90, no. 4, pp. 629–660, 1985.
- [28] G. Medley, H. Guyatt, and D. Bundy, “A quantitative framework for evaluating the effect of community treatment on the morbidity due to ascariasis,” *Parasitology*, vol. 106, no. 2, pp. 211–221, 1993.
- [29] N. C. Lo, I. I. Bogoch, B. G. Blackburn, G. Raso, E. K. N’Goran, J. T. Coulibaly, S. L. Becker, H. B. Abrams, J. Utzinger, and J. R. Andrews, “Comparison of community-wide, integrated mass drug administration strategies for schistosomiasis and soil-transmitted helminthiasis: a cost-effectiveness modelling study,” *J The Lancet Global Health*, vol. 3, no. 10, pp. e629–e638, 2015.

- [30] M. Chan, H. Guyatt, D. A. Bundy, and G. Medley, “The development and validation of an age-structured model for the evaluation of disease control strategies for intestinal helminths,” *Parasitology*, vol. 109, no. 3, pp. 389–396, 1994.
- [31] L. E. Coffeng, R. Bakker, A. Montresor, and S. J. de Vlas, “Feasibility of controlling hookworm infection through preventive chemotherapy: a simulation study using the individual-based wormsims modelling framework,” *Parasites & vectors*, vol. 8, no. 1, p. 541, 2015.
- [32] R. M. Anderson and R. M. May, “Helminth infections of humans: mathematical models, population dynamics, and control,” in *Advances in parasitology*, vol. 24, pp. 1–101, Elsevier, 1985.
- [33] R. M. Anderson and R. M. May, *Infectious diseases of humans: dynamics and control*. Oxford university press, 1992.
- [34] R. M. Anderson, J. E. Truscott, R. L. Pullan, S. J. Brooker, and D. T. Hollingsworth, “How effective is school-based deworming for the community-wide control of soil-transmitted helminths?,” *J PLoS neglected tropical diseases*, vol. 7, no. 2, p. e2027, 2013.
- [35] W. S.-T. Helminthiasis, “Eliminating soil-transmitted helminthiasis as a public health problem in children,” *Progress Report*, vol. 2010, pp. 2011–2020, 2001.
- [36] H. C. Turner, J. Toor, D. T. Hollingsworth, and R. M. Anderson, “Economic evaluations of mass drug administration: The importance of economies of scale and scope,” *J Clinical Infectious Diseases*, vol. 66, no. 8, pp. 1298–1303, 2017.

- [37] A. M. Gray, P. M. Clarke, J. L. Wolstenholme, and S. Wordsworth, *Applied methods of cost-effectiveness analysis in healthcare*, vol. 3. Oxford University Press, 2011.
- [38] S. Tay, W. Twum, H. Abruquah, *et al.*, “Epidemiological survey of soil-transmitted helminths in occupational risk groups and non school going children in the kintampo north district of ghana,” *Journal of the Ghana Science Association*, vol. 12, no. 2, pp. 86–94, 2010.
- [39] R. J. S. Magalhaes, N.-K. Biritwum, J. O. Gyapong, S. Brooker, Y. Zhang, L. Blair, A. Fenwick, and A. C. Clements, “Mapping helminth co-infection and co-intensity: geostatistical prediction in ghana,” *PLoS neglected tropical diseases*, vol. 5, no. 6, p. e1200, 2011.
- [40] L. E. Coffeng, J. E. Truscott, S. H. Farrell, H. C. Turner, R. Sarkar, G. Kang, S. J. de Vlas, and R. M. Anderson, “Comparison and validation of two mathematical models for the impact of mass drug administration on ascaris lumbricoides and hookworm infection,” *Epidemics*, vol. 18, pp. 38 – 47, 2017. Multi-model comparisons for neglected tropical diseases - validation and projection.
- [41] F. Fleming, L. C. Rodrigues, S. Brooker, A. Jardim-Botelho, I. R. Caldas, R. Correa-Oliveira, J. M. Bethony, S. M. Geiger, R. J. Quinnell, and P. J. Hotez, “Age-related changes in hookworm infection, anaemia and iron deficiency in an area of high *Necator americanus* hookworm transmission in south-eastern Brazil,” *Transactions of The Royal Society of Tropical Medicine and Hygiene*, vol. 101, pp. 146–154, 02 2007.

- [42] J. E. Truscott, D. T. Hollingsworth, S. J. Brooker, and R. M. Anderson, “Can chemotherapy alone eliminate the transmission of soil transmitted helminths?,” *J Parasites vectors*, vol. 7, no. 1, p. 266, 2014.
- [43] T. P. for Child Development, “The cost of large-scale school health programmes which deliver anthelmintics to children in Ghana and Tanzania,” *Acta Tropica*, vol. 73, no. 2, pp. 183 – 204, 1999.
- [44] H. C. Turner, M. Y. Osei-Atweneboana, M. Walker, E. J. Tettevi, T. S. Churcher, O. Asiedu, N.-K. Biritwum, and M.-G. Basáñez, “The cost of annual versus biannual community-directed treatment of onchocerciasis with ivermectin: Ghana as a case study,” *J PLoS neglected tropical diseases*, vol. 7, no. 9, p. e2452, 2013.
- [45] J. Keiser and J. Utzinger, “Efficacy of current drugs against soil-transmitted helminth infections: systematic review and meta-analysis,” *Jama*, vol. 299, no. 16, pp. 1937–1948, 2008.
- [46] World Health Organization et. al., *Preventive chemotherapy in human helminthiasis. Coordinated use of anthelmintic drugs in control interventions: a manual for health professionals and programme managers*. World Health Organization, 2006.
- [47] Central Intelligence Agency, “The world factbook: Africa::ghana,” 2018 (Accessed March 16, 2019). https://www.cia.gov/library/publications/the-world-factbook/geos/print_gh.html.
- [48] The Partnership for Child Development, “The cost of large-scale school health programmes which deliver anthelmintics to children in Ghana and Tanzania,” *J Acta Tropica*, vol. 73, no. 2, pp. 183–204, 1999.

- [49] R. S. Bradbury and P. M. Graves, “Current WHO protocols for mass drug administration in helminth control,” *J Microbiology Australia*, vol. 37, no. 1, pp. 10–12, 2016.
- [50] F. Tajebe, M. Getahun, E. Adem, A. Hailu, M. Lemma, H. Fikre, J. Raynes, A. Tamiru, Z. Mulugeta, E. Diro, F. Toulza, Z. Shkedy, T. Ayele, M. Modolell, M. Munder, I. Müller, Y. Takele, and P. Kropf, “Disease severity in patients with visceral leishmaniasis is not altered by co-infection with intestinal parasites,” *PLOS Neglected Tropical Diseases*, vol. 11, no. 7, p. e0005727, 2017.
- [51] D. Mupfasoni, M. Bangert, A. Mikhailov, C. Marocco, and A. Montresor, “Sustained preventive chemotherapy for soil-transmitted helminthiasis leads to reduction in prevalence and anthelmintic tablets required,” *Infectious diseases of poverty*, vol. 8, no. 1, p. 82, 2019.
- [52] R. M. Anderson and R. M. May, “Population dynamics of human helminth infections: control by chemotherapy,” *J Nature*, vol. 297, no. 5867, p. 557, 1982.
- [53] N. de Silva and A. Hall, “Using the prevalence of individual species of intestinal nematode worms to estimate the combined prevalence of any species,” *PLoS neglected tropical diseases*, vol. 4, no. 4, 2010.

DISCUSSION AND CONCLUSIONS

5.1 Role of mathematical modeling in a NTD control

Being neglected, many mechanisms underlying NTD transmission are not completely understood. With uncertainty in non-linearities associated with a mechanism and thus, disease transmission rates, mathematical modeling become critical to the design and study of indirect effects related to implementation of interventions and policies (1; 2). However the awareness about NTDs impacting billions and about the role of mathematical models has been low (3). Through the NTD Consortium and other NTDs' mathematical modeling research around the world, WHO has recognized the importance of such studies for setting control targets for the diseases. They are important for experimentation of policy outcomes which then infer the road map for the disease through the WHO. It is through mathematical modeling that we can incorporate and realize the interplay of different risk factors like socio-economic conditions, health-care awareness and access, sanitation and hygiene etc. with the efficacy of interventions and spread of diseases as well as assessing uncertainties related to these projections (4). Identification and establishment of the importance of different risky behaviors and groups in mathematical projections have been done in the past for diseases like HIV and HPV (5; 6) but such studies for NTDs are limited. Its need is even more crucial for NTDs since the affected regions are resource-limited and the budget needs to be optimal.

Considering these challenges associated with NTDs, I initiated this dissertation with a goal of not only identifying hidden high-risk populations but also designing

and evaluation of interventions related to the high-risk populations when data are scarce. I have developed and analyzed dynamical models for understanding the role of treatment-related behaviors of these hidden high-risk populations on patterns of two distinct diseases Visceral Leishmaniasis (VL) and Soil Transmitted Helminths (STH). Since both the diseases are common in poor communities around the world, we focused our study using data from two ecologically different developing countries, India (for VL) and Ghana (for STH).

5.2 VL dynamics and elimination

Chapters 2 and 3 collect details of my study on VL. Since 2013, 30% of the research on VL prevention and control was based on mathematical epidemiology wherein early diagnosis and vector control have been the primary focuses (7). In this dissertation, we identify treatment non-adherence as a critical factor in shaping patterns of VL. Multiple social risk factors in addition to the long treatment duration for VL and toxic treatment side-effects lead to high treatment non-adherence in Bihar, India. In the context of multiple failed elimination targets for VL in Bihar, we studied how improving treatment adherence can aid existing control programs and the elimination process.

Furthermore, literature review about VL patients intrigued our interest in understanding how difference in causes of treatment non-adherence and difference in treatment behaviors led to varied outcomes in terms of anticipated time to VL elimination in Bihar. It is also important to understand how improving treatment adherence affects VL prevalence in addition to currently implemented sophisticated vector control programs. This analysis is important since it opens the discussion about the future of sustaining VL elimination, especially in poor regions. In other words, my study suggests an estimated treatment adherence level which can control VL in Bihar even

when one or more vector controls are withdrawn in order to reallocate resources to other interventions in resource-limited countries.

5.3 Risk-based MDA for STH control

Chapter 4 provides details of approach and results related to STH in Ghana. MDA has been implemented in Ghana for STH control since the year 2000. Although there has been some relief in STH burden, we are still far away from the WHO goal of bringing the disease level low enough so that it is no longer a public health problem. Various modeling methods (parasite-host ODE and PDE models, simulation models etc.) have been constructed and studied for the past at least half century. Lately there has been a debate about the cost-effectiveness of the community-based MDA in addition to school-based MDA due to higher costs incurred by the former. In the light of this debate, we identified that the school environment is much more contaminated (by infective STH) due to the density and activity of children. The adult school officials working therefore face higher exposure to the infection but have not been part of the MDA efforts potentially due to traditional way of thinking and lack of resources. Thus, I considered a modeling framework which has studied the impact of this high-risk adults school staff when considered under existing MDA programs.

In this work, we have discussed and incorporated a risk-structure framework on the pre-existing age-structure framework commonly used to track patterns of the infected population. By doing this, we could show that having the school-based MDA with treatment to high-risk adults (school officials) was more cost-effective than the current policy given the resource-limited settings of Ghana. Under the limitations of availability of treatment pills, the community-based MDA was less cost-effective than the proposed risk-based MDA policy.

5.4 Limitations

As with any other modeling study, this dissertation has several limitations and we plan to incorporate in our future studies. The models used in dissertation assume homogeneous mixing of populations and their homogeneous behaviors in the region of focus.

For VL elimination, other interventions like early diagnosis and identified risk factors like Post Kala-azar Dermal Leishmaniasis (PKDL) patients who act as reservoirs for VL have not been captured. Due to lack of appropriate data, the VL transmission rates of patients and treatment non-adherers could not be estimated. The only treatment regime captured in our modeling framework is the 28-day Miltefosine course, whereas recurrent treatment non-adherers may be prescribed to the second-line treatment. Each VL model is built with one cause of treatment non-adherence behavior, but the overall causes are diverse (symptoms relief, side-effects, unhappy with health-care officials, prefer traditional cures etc.). Upon identifying the mechanisms of treatment non-adherence based on causes, the heterogeneity may be captured. Since data from interview studies may be biased and from observational studies may be limited, we can get inspiration from works like (8; 9) to construct model-based assessment tool for treatment adherence of patients based on drug concentration. Treatment adherence inevitably contributes in increasing drug resistance. The emergence of Miltefosine failure is being monitored and studied (10). It cannot be used by pregnant women or women who could become pregnant within two months of treatment due to potential birth defects. It can sometimes cause gastrointestinal side-effects. It also stays in the body for a very long time, which could potentially make the parasite resistant to it (11). In the future studies for long-term analysis of use and effect of Miltefosine, the emerging drug resistance and potential risk-groups must be

addressed. The effect of vector control is captured based on a control trial which assumed the effective use of the vector control programs which is highly unlikely. Therefore outcomes may change when these estimates are varied.

For STH modeling, the stratification of populations based on the risk can be made finer (that is capturing farmers and pregnant women). The effects of hygiene and sanitation are captured only as people's behavior. However, the WASH (Water, Sanitation and Hygiene) interventions laid out by the government also affect the hygiene behavior. In this case, the cost of providing infrastructure to the public health system may be added to improve the cost analysis. Furthermore, the economic cost can be computed in presence of more data from Ghana. Nevertheless, this study has provided a new simple modeling framework where the role of dual nature of population stratification incorporating risk- and age-structures, begin to be used in understanding the complex dynamics of STH.

5.5 Challenges associated with using the modeling results

Parameter estimation for Simulation modeling (or Complex Computational Models): The high spatial heterogeneity in both VL and STH cases was discussed in chapters 3 and 4 respectively. Along with this variation in prevalence, the other region-specific attributes may include climate, hospitality of the environment for parasites, people's preventative behaviors, and infrastructure. These lead to different need and effect of the interventions. Spatial agent-based models for disease-spread like EpiSIM (12), EpiSimS (13) and EpiSimdemics (14) have been developed to incorporate the spatially- and individually-varying attributes in models. Agent-based models like these have been used to study disease spread for optimization of resources during epidemics (15; 16; 17). Although these models come close to replicating reality in a specific region, implementing these for NTDs would be extremely difficult

due to the scarcity of data required to parameterize the model. More disease-specific agent-based models like ONCHOSIM (18), SCHISTOSIM (19) and WORMSIM (20) are built and used to optimize MDA. Often they have limited practicability because the parameter estimates are usually derived from local cohort sampling-based studies. The simulation-based models are hard to analyze mathematically, to identify driving mechanisms of a certain outcome, which is crucial in understanding the spread of NTDs for their efficient control.

Epidemiology without borders: Extension of the application of epidemiological tools to non-healthcare problems (like accidents and violence) and inclusion of societal and behavior aspects (for example, role of burial practices in the spread of Ebola and men who have sex with men are high risk groups for HIV) as causative agents of diseases (21). Fine et. al. (2013) discuss how behavioral interventions have proven important in disease control. For example, the interventions were successful when the campaigns are emotionally appealing and relatable for the community— “SuperMums” campaign in Andhra Pradesh, India for defining role of mothers in change in hand-washing habits without any direct health message reduced diarrhea cases in children (22). Using those insights, there might be a need for new non-conventional ways of implementing the results from scientific research. Furthermore, acknowledging the impact of socio-cultural aspects on disease spread and persistence, incorporating them in the transmission dynamics model may be considered.

Integration of sociocultural aspects in models for NTDs: Sociocultural theory focuses on the interactions between developing people (in their societal roles) with the culture (politics, attitudes, education, language, law, etc.) that they live in. The fairly recent integration of sociocultural aspects in disease dynamics needs

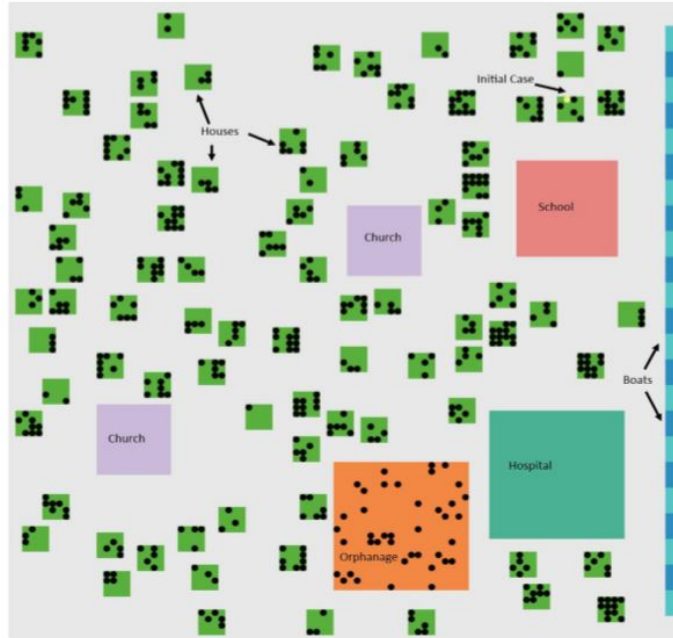

Figure 5.1: Map of system for the agent-based model for the spread of influenza in St. Anthony, Newfoundland by Sattenspiel et. al. (2019) (23). It incorporates socio-cultural aspects by including familial structures, occupations and faith to simulate the movement of each individual in the village.

more exploration (21). Sattenspiel et. al. (2019) discuss how cultural principles can be built into the community in an agent-based model. They do so by including occupations, faith and familial structures on the agents in the system to simulate their movement to observe the spread of influenza in the village St. Anthony in Newfoundland (23). Munday et. al. (2018) demonstrate a way of incorporating the impacts on socio-cultural features on the transmission coefficients and susceptibility of parameters in disease dynamics (24). However, in complex systems like these quantification of social parameters and their precise definitions in the model are crucial for the understanding, implication and replication of the results obtained (25).

Reis and Spencer (2019) discuss the role of stakeholders and science communication through media on policy-making (26). The role of mathematical models in the control of the current COVID-19 pandemic has been published through news articles like (27; 28). These articles, with the use of easy-to-understand flowcharts and language communicate how projections about the pandemic are made. Since the NTDs mostly affect the poverty-ridden neglected masses, communicating the results and basis of the interventions is difficult. People's attitudes and misinformation about the modern medicine and policy-makers in these regions leads to them not complying and cooperating with the interventions (29; 30). Therefore, health education program, one of the agendas of WHO for NTD-control, is critical to develop belief of community in the methods and interventions (31).

Participatory models: Community-based participatory research includes involving the affected community to gain understanding and knowledge about the public health problem (32). Participatory modeling is a modeling technique in which the stakeholders are involved in the process of problem and intervention formulation as well as to understand the mechanisms in the community. This kind of modeling is more common in the field of natural resource management (33; 34). Whiteford and Vindrola-Padros (2015) wrote a book on the role of community participation in sustaining global health goals with examples on the community involvement for behavioral change and social change cross-culturally (35). The impact of community participation shown in various public health intervention examples ((35; 36; 37; 38)) provides an inspiration to participatory modeling for the control of endemic diseases. However, this process is more time-consuming and costly as well as the outcomes are very specific to the community that participated and deriving generalized understanding of the problem is difficult.

	Novelty			
	Epidemiological Perspective	Mathematical Perspective	Scenarios	Empirical Information
Chapter 1	Review of attributes of definitions of “neglected” in NTDs and “vectors”	--	--	--
Chapter 2	--	- Parameter estimation using interview data. - Modeling based health-metrics to quantify case under-reporting	Patients infectious due to treatment non-adherence.	Number of days from symptoms to treatment initiation used to estimate average treatment initiation rate
Chapter 3	Discussion of “nearness” of elimination of VL	- Data-driven modeling. - Model dimension reduction by preserving average waiting time of a class	Effect of perfect adherence to treatment.	Interview data used to estimate average treatment duration of patients.
Chapter 4	Review on various potential high-risk population groups for STH	Building risk-structure into the traditional age-structured models for STH	High-risk adults for hookworm in school environment	--
Chapter 5	Discussion on taking modeling outcomes into communities	--	--	--

Table 5.1: Summary of Novel Theoretical Understandings in This Dissertation for Modeling of NTDs.

Delphi method relies on communication from a panel of experts for problem formulation and policy-making (39). In this dissertation, the questions, modeling and implications, based on the consultation with experts, are primarily theoretical that will provide a baseline for future community-based participation research if sufficient funding and empirical data are available.

5.6 Conclusion: Treatment interventions are effective if risk groups are considered

VL and STH fall in two different categories of NTDs based on the control: Innovative Disease Management (IDM) and Preventive ChemoTherapy (PCT) respectively. This dissertation serves a demonstration of how the definitions of risk groups change based on the kind of the control imposed. Furthermore, it shows how to model these respective risk groups for the outcome to eventually be compared based on the output metric “disease prevalence”. In spite of the above listed limitations, this dissertation

provides a broad understanding of the cruciality of the treatment related risk groups. It identifies and demonstrates modeling techniques for two different types of NTDs in two contrasting country-settings. Instead of a population level rigorous control interventions, identification of these risk groups provides us with strategies for disease control with optimal resources which is critical in the NTD-ridden resource-limited population. In the process of research through the three projects, we achieved some novel (theoretical) understanding related to epidemiological perspective, mathematical perspective, scenario simulations and use of available empirical data in modeling for NTDs (Table 5.1). Through this dissertation we open a discussion to encourage the surveillance to capture the hidden risk groups to obtain accurate health metrics of the region and to design interventions accordingly.

5.7 Future work

This is an initial modeling exercise meant to be built upon for future analyses with more region-specific risk factors and mechanisms to inform intervention policies. Through these models, the importance of these risk groups is established and thus the future implications would be to build in the socio-ecological factors. Apart from vector control, the other interventions being tested and implemented are early diagnosis and treatment of PKDL patients who are typically a few in number but act as reservoirs for VL. We plan on analyzing the model with all these interventions together to analyze the global sensitivity of the VL endemicity on each of them and all of them taken together. For the control of STH, in the future we would like to incorporate (i) the class ineligible for treatment specifically (like pregnant women and infants), (ii) systematic non-adherence of MDA (that is when a specific group of people is consistently missed during every MDA round), and (iii) the non-adherence arising

out of people's refusal to treatment (which may be caused due to social stigma about STH and disbelief in the medicine).

In a hypothetical situation of redoing this dissertation, there are a few things that I would do differently. I would have tried to benefit from my committee members' expertise much more. For example, I would have tried to quantify the vector-related parameters, including vector-control, with the help of Dr. Paaijmans (entomologist; Arizona State University). With the help of Dr. Hurtado (anthropologist; Arizona State University), I would attempt at understanding people's perceptions and attitudes towards MDA and assessing different adult risk-groups in more detail to have a better informed parameter estimates. I would have used the help of Dr. Michael (parasitologist; University of Notre Dame) to incorporate the impact of WASH interventions in the cost analysis of MDA for hookworm. Apart from this, I would have tried to collaborate with Dr. Sundar (Programme Director, Kala-Azar Medical Research Centre) to get district-level recent monthly VL prevalence and treatment-related data in Bihar for model validation.

I hope the advances in modeling results of VL and STH presented in this dissertation should one day translate into a new and robust pipeline for evaluating and optimizing treatment access, diagnostics, and adherence related policies for targeting high-risk groups of the populations. Compliance with the principles and strategies from this study would require a change in political thinking in the neglected regions in order to achieve persistent NTD-control. We have outlined novel low-cost strategies to control the two diseases through preventive interventions.

REFERENCES

- [1] H. C. Turner, M. Walker, T. S. Churcher, M. Y. Osei-Atweneboana, N.-K. Biritwum, A. Hopkins, R. K. Prichard, and M.-G. Basáñez, “Reaching the london declaration on neglected tropical diseases goals for onchocerciasis: an economic evaluation of increasing the frequency of ivermectin treatment in africa,” *Clinical Infectious Diseases*, vol. 59, no. 7, pp. 923–932, 2014.
- [2] M. Kretzschmar, “Disease modeling for public health: added value, challenges, and institutional constraints,” *Journal of public health policy*, vol. 41, no. 1, pp. 39–51, 2020.
- [3] A. Kealey *et al.*, “Neglected tropical diseases: infection, modeling, and control,” *Journal of health care for the poor and underserved*, vol. 21, no. 1, pp. 53–69, 2010.
- [4] M. Keeling and L. Danon, “Mathematical modelling of infectious diseases.,” *British Medical Bulletin*, vol. 92, no. 1, 2009.
- [5] S. B. Kim, M. Yoon, N. S. Ku, M. H. Kim, J. E. Song, J. Y. Ahn, S. J. Jeong, C. Kim, H.-D. Kwon, J. Lee, *et al.*, “Mathematical modeling of hiv prevention measures including pre-exposure prophylaxis on hiv incidence in south korea,” *PloS one*, vol. 9, no. 3, 2014.
- [6] A. Huppert and G. Katriel, “Mathematical modelling and prediction in infectious disease epidemiology,” *Clinical microbiology and infection*, vol. 19, no. 11, pp. 999–1005, 2013.
- [7] K. Bi, Y. Chen, S. Zhao, Y. Kuang, and C.-H. John Wu, “Current visceral leishmaniasis research: a research review to inspire future study,” *BioMed research international*, vol. 2018, 2018.

- [8] G. Greene, R. W. Costello, B. Cushen, I. Sulaiman, E. Mac Hale, R. M. Conroy, and F. Doyle, “A novel statistical method for assessing effective adherence to medication and calculating optimal drug dosages,” *PloS one*, vol. 13, no. 4, 2018.
- [9] A. Schlender, P. E. Alperin, H. L. Grossman, and E. R. Sutherland, “Modeling the impact of increased adherence to asthma therapy,” *PLoS One*, vol. 7, no. 12, 2012.
- [10] Ostyn B., Hasker E., Dorlo T. P. C., Rijal S., Sundar S., Dujardin J.-C., Boelaert M., “Failure of Miltefosine Treatment for Visceral Leishmaniasis in Children and Men in South-East Asia,” *PLOS ONE*, vol. 9, pp. 1–8, 06 2014.
- [11] World Health Organization: Regional Office for South-East Asia, “Frequently Asked questions on Visceral leishmaniasis (kala-azar),” 2013. <http://apps.who.int/iris/bitstream/10665/205090/1/B5042.pdf?ua=1>.
- [12] J. M. D. A. Simones, *An agent-based approach to spatial epidemics through GIS*. University of London, University College London (United Kingdom), 2007.
- [13] P. Stroud, S. Del Valle, S. Sydoriak, J. Riese, and S. Mniszewski, “Spatial dynamics of pandemic influenza in a massive artificial society,” *Journal of Artificial Societies and Social Simulation*, vol. 10, no. 4, p. 9, 2007.
- [14] C. L. Barrett, K. R. Bisset, S. G. Eubank, X. Feng, and M. V. Marathe, “EpiSimdemics: an efficient algorithm for simulating the spread of infectious disease over large realistic social networks,” in *High Performance Computing, Networking, Storage and Analysis, 2008. SC 2008. International Conference for*, pp. 1–12, IEEE, 2008.

- [15] S. M. Mniszewski, S. Y. Del Valle, P. D. Stroud, J. M. Riese, and S. J. Sydoriak, “Episims simulation of a multi-component strategy for pandemic influenza,” in *Proceedings of the 2008 Spring simulation multiconference*, pp. 556–563, Society for Computer Simulation International, 2008.
- [16] L. Perez and S. Dragicevic, “An agent-based approach for modeling dynamics of contagious disease spread,” *International journal of health geographics*, vol. 8, no. 1, p. 50, 2009.
- [17] E. Hunter, B. Mac Namee, and J. Kelleher, “Correction: An open-data-driven agent-based model to simulate infectious disease outbreaks,” *PloS one*, vol. 14, no. 1, p. e0211245, 2019.
- [18] A. Plaisier, G. Van Oortmarsen, J. Habbema, J. Remme, and E. Alley, “Onchosim: a model and computer simulation program for the transmission and control of onchocerciasis,” *Computer methods and programs in biomedicine*, vol. 31, no. 1, pp. 43–56, 1990.
- [19] S. De Vlas, G. Van Oortmarsen, B. Gryseels, A. Polderman, A. Plaisier, and J. Habbema, “Schistosim: a microsimulation model for the epidemiology and control of schistosomiasis,” *The American journal of tropical medicine and hygiene*, vol. 55, no. 5_Suppl, pp. 170–175, 1996.
- [20] L. E. Coffeng, R. Bakker, A. Montresor, and S. J. de Vlas, “Feasibility of controlling hookworm infection through preventive chemotherapy: a simulation study using the individual-based wormsim modelling framework,” *Parasites & vectors*, vol. 8, no. 1, p. 541, 2015.

- [21] J. Bedford, J. Farrar, C. Ihekweazu, G. Kang, M. Koopmans, and J. Nkengasong, “A new twenty-first century science for effective epidemic response,” *Nature*, vol. 575, no. 7781, pp. 130–136, 2019.
- [22] P. Fine, C. G. Victora, K. J. Rothman, P. S. Moore, Y. Chang, V. Curtis, D. L. Heymann, G. Slutkin, R. M. May, V. Patel, *et al.*, “John snow’s legacy: epidemiology without borders,” *The Lancet*, vol. 381, no. 9874, pp. 1302–1311, 2013.
- [23] L. Sattenspiel, J. Dimka, and C. Orbann, “Using cultural, historical, and epidemiological data to inform, calibrate, and verify model structures in agent-based simulations,” *Mathematical biosciences and engineering: MBE*, vol. 16, no. 4, pp. 3071–3093, 2019.
- [24] J. D. Munday, A. J. van Hoek, W. J. Edmunds, and K. E. Atkins, “Quantifying the impact of social groups and vaccination on inequalities in infectious diseases using a mathematical model,” *BMC medicine*, vol. 16, no. 1, p. 162, 2018.
- [25] C. Orbann, L. Sattenspiel, E. Miller, and J. Dimka, “Defining epidemics in computer simulation models: How do definitions influence conclusions?,” *Epidemics*, vol. 19, pp. 24–32, 2017.
- [26] J. Reis and P. S. Spencer, “Decision-making under uncertainty in environmental health policy: new approaches,” *Environmental health and preventive medicine*, vol. 24, no. 1, pp. 1–8, 2019.
- [27] M. Burkhardt, “Estimating possibly undetected covid-19 infection cases,” 2020.
- [28] N. I. o. G. M. S. N. NIH, “What is computer modeling and how does it work?.”

- [29] C. I. Anumudu, O. S. Onile, H. Awobode, A. Gboyega-Tokunbo, V. Oladele, A. Adebayo, and C. O. Chouvwen, “Socio-cultural and environmental determinants of a proposed schistosomiasis health education intervention in eggua, nigeria,” 2019.
- [30] H. T. Melkamu, A. M. Beyene, and D. T. Zegeye, “Knowledge, attitude and practices of the resident community about visceral leishmaniasis in west armachiho district, northwest ethiopia,” *Heliyon*, vol. 6, no. 1, p. e03152, 2020.
- [31] A. Price, A. Verma, and W. Welfare, “Are health education interventions effective for the control and prevention of urogenital schistosomiasis in sub-saharan africa? a systematic review,” *Transactions of The Royal Society of Tropical Medicine and Hygiene*, vol. 109, no. 4, pp. 239–244, 2015.
- [32] B. A. Israel, A. J. Schulz, E. A. Parker, and A. B. Becker, “Review of community-based research: assessing partnership approaches to improve public health,” *Annual review of public health*, vol. 19, no. 1, pp. 173–202, 1998.
- [33] N. A. Jones, P. Perez, T. G. Measham, G. J. Kelly, P. d’Aquino, K. A. Daniell, A. Dray, and N. Ferrand, “Evaluating participatory modeling: developing a framework for cross-case analysis,” *Environmental management*, vol. 44, no. 6, p. 1180, 2009.
- [34] G. A. Mendoza and R. Prabhu, “Participatory modeling and analysis for sustainable forest management: Overview of soft system dynamics models and applications,” *Forest Policy and Economics*, vol. 9, no. 2, pp. 179–196, 2006.
- [35] L. M. Whiteford and C. Vindrola-Padros, *Community participatory involvement: A sustainable model for global public health*. Left Coast Press, 2015.

- [36] J. D. Mbako, D. Barffo, R. K. Nuotol, R. Alebshehy, and N. M. Shuaib, “Enhancing malaria prevention in cameroon through community participation: an in-depth review,” *Central African Journal of Public Health*, vol. 3, no. 6, p. 97, 2017.
- [37] S. Madon, M. N. Malecela, K. Mashoto, R. Donohue, G. Mubyazi, and E. Michael, “The role of community participation for sustainable integrated neglected tropical diseases and water, sanitation and hygiene intervention programs: A pilot project in tanzania,” *Social Science & Medicine*, vol. 202, pp. 28–37, 2018.
- [38] M. Brear, K. Hammarberg, and J. Fisher, “Community participation in research from resource-constrained countries: a scoping review,” *Health Promotion International*, vol. 33, no. 4, pp. 723–733, 2018.
- [39] B. B. Brown, “Delphi process: a methodology used for the elicitation of opinions of experts,” tech. rep., Rand Corp Santa Monica CA, 1968.

REFERENCES

- [1] Ostyn B., Hasker E., Dorlo T. P. C., Rijal S., Sundar S., Dujardin J.-C., Boelaert M., “Failure of Miltefosine Treatment for Visceral Leishmaniasis in Children and Men in South-East Asia,” *PLOS ONE*, vol. 9, pp. 1–8, 06 2014.
- [2] “Parasites- Hookworm,” 2013. <https://www.cdc.gov/parasites/hookworm/index.html>.
- [3] A. Loukas, P. J. Hotez, D. Diemert, M. Yazdanbakhsh, J. S. McCarthy, R. Correa-Oliveira, J. Croese, and J. M. Bethony, “Hookworm infection,” *Nature Reviews Disease Primers*, vol. 2, p. 16088, 2016.
- [4] L. Sattenspiel, J. Dimka, and C. Orbann, “Using cultural, historical, and epidemiological data to inform, calibrate, and verify model structures in agent-based simulations,” *Mathematical biosciences and engineering: MBE*, vol. 16, no. 4, pp. 3071–3093, 2019.
- [5] W. H. Organization *et al.*, “Working to overcome the global impact of neglected tropical diseases: first who report on neglected tropical diseases: update 2011,” 2011.
- [6] W. H. Organization *et al.*, “Ending the neglect to attain the sustainable development goals,” 2020.
- [7] W. H. Organization *et al.*, “Global plan to combat neglected tropical diseases 2008-2015,” tech. rep., Geneva: World Health Organization, 2007.
- [8] P. J. Hotez, “Ntids v. 2.0: “blue marble health”—neglected tropical disease control and elimination in a shifting health policy landscape,” *Plos Neglected Tropical Diseases*, vol. 7, no. 11, 2013.
- [9] Y. Zhang, C. MacArthur, L. Mubila, and S. Baker, “Control of neglected tropical diseases needs a long-term commitment,” *BMC medicine*, vol. 8, no. 1, p. 67, 2010.
- [10] U. to Combat NTDs, “London declaration on neglected tropical diseases,” 2012.
- [11] T. K. Mackey, B. A. Liang, R. Cuomo, R. Hafen, K. C. Brouwer, and D. E. Lee, “Emerging and reemerging neglected tropical diseases: a review of key characteristics, risk factors, and the policy and innovation environment,” *Clinical microbiology reviews*, vol. 27, no. 4, pp. 949–979, 2014.
- [12] A. K. Mitra and A. R. Mawson, “Neglected tropical diseases: epidemiology and global burden,” *Tropical medicine and infectious disease*, vol. 2, no. 3, p. 36, 2017.
- [13] J. Aagaard-Hansen, C. L. Chagnat, *et al.*, “Neglected tropical diseases: equity and social determinants,” *Equity, social determinants and public health programmes*, vol. 135, 2010.

- [14] K. I. C. Ong, H. Araki, S. Kano, and M. Jimba, “The potential of positive deviance approach for the sustainable control of neglected tropical diseases,” *Tropical medicine and health*, vol. 44, no. 1, p. 20, 2016.
- [15] X.-N. Zhou, R. Bergquist, and M. Tanner, “Elimination of tropical disease through surveillance and response,” 2013.
- [16] E. Tambo, L. Ai, X. Zhou, J.-H. Chen, W. Hu, R. Bergquist, J.-G. Guo, J. Utzinger, M. Tanner, and X.-N. Zhou, “Surveillance-response systems: the key to elimination of tropical diseases,” *Infectious diseases of poverty*, vol. 3, no. 1, p. 17, 2014.
- [17] T. T. F. for Global Health, “Disease surveillance,” Accessed April 2020.
- [18] C. L. Gibbons, M.-J. J. Mangen, D. Plass, A. H. Havelaar, R. J. Brooke, P. Kra-marz, K. L. Peterson, A. L. Stuurman, A. Cassini, E. M. Fèvre, *et al.*, “Measuring underreporting and under-ascertainment in infectious disease datasets: a comparison of methods,” *BMC public health*, vol. 14, no. 1, p. 147, 2014.
- [19] P. Hotez and S. Aksoy, “Plos neglected tropical diseases: Ten years of progress in neglected tropical disease control and elimination. . . more or less,” 2017.
- [20] K. Bardosh, “Global aspirations, local realities: the role of social science research in controlling neglected tropical diseases,” *Infectious diseases of poverty*, vol. 3, no. 1, p. 35, 2014.
- [21] S. Madon, M. N. Malecela, K. Mashoto, R. Donohue, G. Mubyazi, and E. Michael, “The role of community participation for sustainable integrated neglected tropical diseases and water, sanitation and hygiene intervention programs: A pilot project in tanzania,” *Social Science & Medicine*, vol. 202, pp. 28–37, 2018.
- [22] S. Pokhrel, D. Reidpath, and P. Allotey, “Social sciences research in neglected tropical diseases 3: Investment in social science research in neglected diseases of poverty: a case study of bill and melinda gates foundation,” *Health research policy and systems*, vol. 9, no. 1, p. 2, 2011.
- [23] F. Brauer, “Mathematical epidemiology: Past, present, and future,” *Infectious Disease Modelling*, vol. 2, no. 2, pp. 113–127, 2017.
- [24] T. D. Hollingsworth, E. R. Adams, R. M. Anderson, K. Atkins, S. Bartsch, M.-G. Basáñez, M. Behrend, D. J. Blok, L. A. Chapman, L. Coffeng, *et al.*, “Quantitative analyses and modelling to support achievement of the 2020 goals for nine neglected tropical diseases,” *Parasites & vectors*, vol. 8, no. 1, p. 630, 2015.
- [25] A. Kealey *et al.*, “Neglected tropical diseases: infection, modeling, and control,” *Journal of health care for the poor and underserved*, vol. 21, no. 1, pp. 53–69, 2010.

- [26] P. J. Hotez and A. Kamath, “Neglected tropical diseases in sub-saharan africa: review of their prevalence, distribution, and disease burden,” *PLoS neglected tropical diseases*, vol. 3, no. 8, 2009.
- [27] Z. A. Bhutta, J. Sommerfeld, Z. S. Lassi, R. A. Salam, and J. K. Das, “Global burden, distribution, and interventions for infectious diseases of poverty,” *Infectious diseases of poverty*, vol. 3, no. 1, p. 21, 2014.
- [28] P. J. Hotez, N.-K. Biritwum, A. Fenwick, D. H. Molyneux, and J. D. Sachs, “Ghana: Accelerating neglected tropical disease control in a setting of economic development,” *PLoS neglected tropical diseases*, vol. 13, no. 1, 2019.
- [29] D. Humphries, E. Mosites, J. Otchere, W. A. Twum, L. Woo, H. Jones-Sanpei, L. M. Harrison, R. D. Bungiro, B. Benham-Pyle, L. Bimi, *et al.*, “Epidemiology of hookworm infection in kintampo north municipality, ghana: patterns of malaria coinfection, anemia, and albendazole treatment failure,” *The American journal of tropical medicine and hygiene*, vol. 84, no. 5, pp. 792–800, 2011.
- [30] World Health Organization: Media, “Leishmaniasis,” April 2017. <http://www.who.int/mediacentre/factsheets/fs375/en/>.
- [31] D. Bora, “Epidemiology of visceral leishmaniasis in india,” *National Medical Journal of India*, vol. 12, pp. 62–68, 1999.
- [32] D. L. Sacks, “Leishmania–sand fly interactions controlling species-specific vector competence: Microreview,” *Cellular microbiology*, vol. 3, no. 4, pp. 189–196, 2001.
- [33] F. Chappuis, S. Sundar, A. Hailu, H. Ghalib, S. Rijal, R. W. Peeling, J. Alvar, and M. Boelaert, “Visceral leishmaniasis: what are the needs for diagnosis, treatment and control?,” *Nature reviews microbiology*, vol. 5, no. 11, pp. 873–882, 2007.
- [34] T. Ilg, Y.-D. Stierhof, M. Wiese, M. McConville, and P. Overath, “Characterization of phosphoglycan-containing secretory products of leishmania,” *Parasitology*, vol. 108, no. S1, pp. S63–S71, 1994.
- [35] R. Lodge and A. Descoteaux, “Leishmania invasion and phagosome biogenesis,” in *Molecular Mechanisms of Parasite Invasion*, pp. 174–181, Springer, 2008.
- [36] R. Pulvertaft and G. Hoyle, “Stages in the life-cycle of leishmania donovani,” *Transactions of the Royal Society of Tropical Medicine and Hygiene*, vol. 54, no. 2, pp. 191–196, 1960.
- [37] S. Sundar, D. Mondal, S. Rijal, S. Bhattacharya, H. Ghalib, A. Kroeger, M. Boelaert, P. Desjeux, H. Richter-Airijoki, and G. Harms, “Implementation research to support the initiative on the elimination of kala azar from bangladesh, india and nepal—the challenges for diagnosis and treatment,” *Tropical Medicine & International Health*, vol. 13, no. 1, pp. 2–5, 2008.

- [38] S. Sundar, A. Singh, M. Rai, V. K. Prajapati, A. K. Singh, B. Ostyn, M. Boelaert, J.-C. Dujardin, and J. Chakravarty, “Efficacy of miltefosine in the treatment of visceral leishmaniasis in india after a decade of use,” *Clinical infectious diseases*, vol. 55, no. 4, pp. 543–550, 2012.
- [39] Hugtenburg J. G., Timmers L., Elders P. J. M., Vervloet M., van Dijk L., “Definitions, variants, and causes of nonadherence with medication: a challenge for tailored interventions,” *Patient Preference and Adherence*, vol. 7, pp. 675–682, 2013.
- [40] Kansal, S., Chakravarty, J., Kumar, A., Malaviya, P., Boelaert, M., Hasker, E., Ostyn, B., Sundar, S., “Risk Factors associated with defaulting from visceral leishmaniasis treatment: analysis under routine programme conditions in Bihar, India,” *Tropical Medicine & International Health*, vol. 22, no. 8, pp. 1037–1042, 2017.
- [41] Uranw S., Ostyn B., Dorlo T. P.C., Hasker E., Dujardin B., Dujardin J. C., Rijal S., Boelaert M., “Adherence to miltefosine treatment for visceral leishmaniasis under routine conditions in Nepal,” *Trop Med Int Health*, vol. 18, pp. 179–187, 2013.
- [42] E. Sabaté, E. Sabaté, *et al.*, *Adherence to long-term therapies: evidence for action*. World Health Organization, 2003.
- [43] Tedla Y. G. and Bautista L. E., “Drug Side Effect Symptoms and Adherence to Antihypertensive Medication,” 2015.
- [44] Bosworth H. B., “Enhancing medication adherence: The public health dilemma,” 2014.
- [45] Torrey T., “Reasons patients don’t comply with treatment recommendations,”
- [46] Mondal D., Singh S. P., Kumar N., Joshi A., Sundar S., Das P., Siddhivinayak H., Kroeger A., Boelaert M., “Visceral Leishmaniasis Elimination Programme in India, Bangladesh, and Nepal: Reshaping the Case Finding/Case Management Strategy,” *PLOS Neglected Tropical Diseases*, vol. 3, no. 1, pp. 1–8, 2009.
- [47] Lee H. J., Jang S. I., Park E. C., “Effect of adherence to antihypertensive medication on stroke incidence in patients with hypertension: a population-based retrospective cohort study,” *BMJ Open*, vol. 7, 2017.
- [48] M. A. M. A. DebRoy S., Prosper O., “Challenges in modeling complexity of neglected tropical diseases: a review of dynamics of visceral leishmaniasis in resource limited settings,”
- [49] J. P. Boettcher, Y. Siwakoti, A. Milojkovic, N. A. Siddiqui, C. K. Gurung, S. Rijal, P. Das, A. Kroeger, and M. R. Banjara, “Visceral leishmaniasis diagnosis and reporting delays as an obstacle to timely response actions in nepal and india,” *BMC infectious diseases*, vol. 15, no. 1, p. 43, 2015.

- [50] C. Dye and D. M. Wolpert, “Earthquakes, influenza and cycles of indian kala-azar,” *Transactions of the Royal Society of Tropical Medicine and Hygiene*, vol. 82, no. 6, pp. 843–850, 1988.
- [51] A. Mubayi, C. Castillo-Chavez, G. Chowell, C. Kribs-Zaleta, N. A. Siddiqui, N. Kumar, and P. Das, “Transmission dynamics and underreporting of kala-azar in the indian state of bihar,” *Journal of theoretical biology*, vol. 262, no. 1, pp. 177–185, 2010.
- [52] A. Stauch, R. R. Sarkar, A. Picado, B. Ostyn, S. Sundar, S. Rijal, M. Boelaert, J.-C. Dujardin, and H.-P. Duerr, “Visceral leishmaniasis in the indian subcontinent: modelling epidemiology and control,” *PLoS neglected tropical diseases*, vol. 5, no. 11, 2011.
- [53] Stauch A., Duerr H.-P., Picado A., Ostyn B., Sundar S., Rijal S., Boelaert M., Dujardin J.-C., Eichner M., “Model-Based Investigations of Different Vector-Related Intervention Strategies to Eliminate Visceral Leishmaniasis on the Indian Subcontinent,” *PLOS Neglected Tropical Diseases*, vol. 8, pp. 1–9, 04 2014.
- [54] Medley G. F., Hollingsworth T. D., Olliaro P. L., Adams E. R., “Health-seeking behaviour, diagnostics and transmission dynamics in the control of visceral leishmaniasis in the Indian subcontinent.,” *Nature*, vol. 528, no. 7580, pp. S102–8, 2015.
- [55] S. Mushayabasa, C. Bhunu, and M. Dhlamini, “Understanding non-compliance with who multidrug therapy among leprosy patients: insights from a mathematical model,” *Understanding the Dynamics of Emerging and Re-Emerging Infectious Diseases using mathematical models. Kerala, India: Transworld Research Network*, pp. 1–22, 2012.
- [56] M. O. Fofana, G. M. Knight, G. B. Gomez, R. G. White, and D. W. Dowdy, “Population-level impact of shorter-course regimens for tuberculosis: a model-based analysis,” *PloS one*, vol. 9, no. 5, 2014.
- [57] R. A. Elliott, J. A. Shinogle, P. Peele, M. Bhosle, and D. A. Hughes, “Understanding medication compliance and persistence from an economics perspective,” *Value in health*, vol. 11, no. 4, pp. 600–610, 2008.
- [58] S. Dash, P. N. Murthy, L. Nath, P. Chowdhury, *et al.*, “Kinetic modeling on drug release from controlled drug delivery systems,” *Acta Pol Pharm*, vol. 67, no. 3, pp. 217–23, 2010.
- [59] J. Urquhart, “Pharmacodynamics of variable patient compliance: implications for pharmaceutical value,” *Advanced drug delivery reviews*, vol. 33, no. 3, pp. 207–219, 1998.
- [60] M. Lipsitch and B. R. Levin, “Population dynamics of tuberculosis treatment: mathematical models of the roles of non-compliance and bacterial heterogeneity in the evolution of drug resistance,” *The International Journal of Tuberculosis and Lung Disease*, vol. 2, no. 3, pp. 187–199, 1998.

- [61] F. B. Agosto, M. I. Teboh-Ewungkem, and A. B. Gumel, “Mathematical assessment of the effect of traditional beliefs and customs on the transmission dynamics of the 2014 ebola outbreaks,” *BMC medicine*, vol. 13, no. 1, p. 96, 2015.
- [62] F. Agosto and A. Adekunle, “Optimal control of a two-strain tuberculosis-hiv/aids co-infection model,” *Biosystems*, vol. 119, pp. 20 – 44, 2014.
- [63] S. Mushayabasa and C. Bhunu, “Modeling the impact of early therapy for latent tuberculosis patients and its optimal control analysis,” *Journal of biological physics*, vol. 39, no. 4, pp. 723–747, 2013.
- [64] S. H. Farrell, J. E. Truscott, and R. M. Anderson, “The importance of patient compliance in repeated rounds of mass drug administration (mda) for the elimination of intestinal helminth transmission,” *Parasites & vectors*, vol. 10, no. 1, p. 291, 2017.
- [65] M. O. Fofana, G. M. Knight, G. B. Gomez, R. G. White, and D. W. Dowdy, “Population-level impact of shorter-course regimens for tuberculosis: A model-based analysis,” *PLOS ONE*, vol. 9, pp. 1–7, 05 2014.
- [66] F. Weiss, N. Vogenthaler, C. Franco-Paredes, and S. R. Parker, “Leishmania tropica-induced cutaneous and presumptive concomitant viscerotropic leishmaniasis with prolonged incubation,” *Archives of dermatology*, vol. 145, no. 9, pp. 1023–1026, 2009.
- [67] E. Agyingi and T. Wiandt, “Analysis of a model of leishmaniasis with multiple time lags in all populations,” *Mathematical and Computational Applications*, vol. 24, no. 2, p. 63, 2019.
- [68] N. Hussaini, K. Okuneye, and A. B. Gumel, “Mathematical analysis of a model for zoonotic visceral leishmaniasis,” *Infectious Disease Modelling*, vol. 2, no. 4, pp. 455–474, 2017.
- [69] P. Manson-Bahr, “Immunity in kala-azar,” *Transactions of the Royal Society of Tropical Medicine and Hygiene*, vol. 55, no. 6, pp. 550–555, 1961.
- [70] J. M. Medlock, K. M. Hansford, W. Van Bortel, H. Zeller, and B. Alten, “A summary of the evidence for the change in european distribution of phlebotomine sand flies (diptera: Psychodidae) of public health importance,” *Journal of Vector Ecology*, vol. 39, no. 1, pp. 72–77, 2014.
- [71] F. M. Simsek, B. Alten, S. S. Caglar, Y. Ozbek, A. M. Aytakin, S. Kaynas, A. Belen, O. E. Kasap, M. Yaman, and S. Rastgeldi, “Distribution and altitudinal structuring of phlebotomine sand flies (diptera: Psychodidae) in southern anatolia, turkey: their relation to human cutaneous leishmaniasis,” *Journal of Vector Ecology*, vol. 32, no. 2, pp. 269–279, 2007.
- [72] Thieme H. R., *Mathematics in population biology*. Princeton University Press, 2018.

- [73] P. Van den Driessche and J. Watmough, “Reproduction numbers and sub-threshold endemic equilibria for compartmental models of disease transmission,” *Mathematical biosciences*, vol. 180, no. 1-2, pp. 29–48, 2002.
- [74] A. Gumel, “Causes of backward bifurcations in some epidemiological models,” *Journal of Mathematical Analysis and Applications*, vol. 395, no. 1, pp. 355–365, 2012.
- [75] F. Brauer, “A singular perturbation approach to epidemics of vector-transmitted diseases,” *Infectious Disease Modelling*, vol. 4, pp. 115–123, 2019.
- [76] Pandey A., Mubayi A., Medlock J., “Comparing vector–host and SIR models for dengue transmission,” *Mathematical Biosciences*, vol. 246, no. 2, pp. 252 – 259, 2013.
- [77] M. J. Keeling and P. Rohani, *Modeling infectious diseases in humans and animals*. Princeton University Press, 2011.
- [78] Census Organization of India, “District census 2011,” 2015 (Accessed March 23, 2019).
- [79] S. Biswas, “Mathematical modeling of visceral leishmaniasis and control strategies,” *Chaos, Solitons & Fractals*, vol. 104, pp. 546–556, 2017.
- [80] ELmojtaba I. M., Mugisha J.Y.T., Hashim M. H. A., “Mathematical analysis of the dynamics of visceral leishmaniasis in the Sudan,” *Applied Mathematics and Computation*, vol. 217, no. 6, pp. 2567 – 2578, 2010.
- [81] Sundar S., Olliaro P. L., “Miltefosine in the treatment of leishmaniasis: clinical evidence for informed clinical risk management,” *Therapeutics and clinical risk management*, vol. 3, no. 5, p. 733, 2007.
- [82] C. S. L. B. M. Burza, S., “Leishmaniasis,” *Lancet (London, England)*, vol. 392, no. 10151, pp. 951–970, 2018.
- [83] T. P. Dorlo, M. Balasegaram, J. H. Beijnen, and P. J. de Vries, “Miltefosine: a review of its pharmacology and therapeutic efficacy in the treatment of leishmaniasis,” *Journal of Antimicrobial Chemotherapy*, vol. 67, no. 11, pp. 2576–2597, 2012.
- [84] W. H. Organization, UNICEF, *et al.*, “Global vector control response 2017–2030,” 2017.
- [85] National Vector Borne Disease Control Programme: WHO country office for India, “Accelerated Plan for Kala-azar Elimination 2017,” http://www.who.int/leishmaniasis/resources/Accelerated-Plan-Kala-azar1-Feb2017_light.pdf?ua=1.
- [86] World Health Organization: Regional Office for South-East Asia, “Frequently Asked questions on Visceral leishmaniasis (kala-azar),” 2013. <http://apps.who.int/iris/bitstream/10665/205090/1/B5042.pdf?ua=1>.

- [87] A. B. Joshi, M. L. Das, S. Akhter, R. Chowdhury, D. Mondal, V. Kumar, P. Das, A. Kroeger, M. Boelaert, and M. Petzold, “Chemical and environmental vector control as a contribution to the elimination of visceral leishmaniasis on the indian subcontinent: cluster randomized controlled trials in bangladesh, india and nepal,” *BMC medicine*, vol. 7, no. 1, p. 54, 2009.
- [88] NVBDCP, “Manual on integrated vector management india,” 2015.
- [89] Picado A., Dash A. P., Bhattacharya S., Boelaert M., “Vector control interventions for visceral leishmaniasis elimination initiative in South Asia, 2005-2010,” *The Indian journal of medical research*, vol. 136, no. 1, p. 22, 2012.
- [90] S. S. Singh R. K., Pandey H. P., “Visceral leishmaniasis (kala-azar): challenges ahead,”
- [91] Smits H. L., “Prospects for the control of neglected tropical diseases by mass drug administration,” *Expert review of anti-infective therapy*, vol. 7, no. 1, pp. 37–56, 2009.
- [92] Singh O. P., Sundar S., “Developments in diagnosis of visceral leishmaniasis in the elimination era,” *Journal of parasitology research*, vol. 2015, 2015.
- [93] Shimozako H. J., Wu J., Massad E., “Mathematical modelling for Zoonotic Visceral Leishmaniasis dynamics: A new analysis considering updated parameters and notified human Brazilian data,” *Infectious Disease Modelling*, vol. 2, no. 2, pp. 143 – 160, 2017.
- [94] Singh V. P. and Ranjan A., Topno R. K., Verma R. B., Siddique N. A., Ravidas V. N., Kumar N., Pandey K., Das P., “Estimation of under-reporting of visceral leishmaniasis cases in Bihar, India,” *The American journal of tropical medicine and hygiene*, vol. 82, no. 1, pp. 9–11, 2010.
- [95] Gorahava K. K., Rosenberger J. M., Mubayi A., “Optimizing insecticide allocation strategies based on houses and livestock shelters for visceral leishmaniasis control in Bihar, India,” *The American journal of tropical medicine and hygiene*, vol. 93, no. 1, pp. 114–122, 2015.
- [96] K. Gorahava, “Optimization models for leishmaniasis control: A case for bihar, india,” 2013.
- [97] Gonzalez B., *Quantitative Modeling Methods For Analyzing Clinical To Public Health Problems*. Arizona State University, 2015.
- [98] C. Kribs-Zaleta, N. A. Siddiqui, N. Kumar, and P. Das, “The control reproduction number and case-underreporting of visceral leishmaniasis in bihar, india,” 2009.
- [99] Mubayi A., “Chapter 7 - Inferring Patterns, Dynamics, and Model-Based Metrics of Epidemiological Risks of Neglected Tropical Diseases,” in *Disease Modelling and Public Health, Part B* (R. C. R. Rao A. S. R. S., Pyne S., ed.), vol. 37 of *Handbook of Statistics*, pp. 155 – 183, Elsevier, 2017.

- [100] Morales D., Paredes M., Mubayi A., “Dynamics of Cutaneous Leishmaniasis Infection in the Presence of Bird Reservoirs as a Tool for Vector Surveillance in Ecuador,” 2016.
- [101] Singh S. P., Reddy D. C. S., Rai M., Sundar S., “Serious underreporting of visceral leishmaniasis through passive case reporting in Bihar, India,” *Tropical Medicine & International Health*, vol. 11, no. 6, pp. 899–905, 2006.
- [102] Chomel B., “Surveillance of Visceral Leishmaniasis,” *Consulta de expertos OPS/OMS sobre Leishmaniasis Visceral en las Américas*, p. 121.
- [103] Galatas B., Bassat Q., Mayor A., “Malaria Parasites in the Asymptomatic: Looking for the Hay in the Haystack,” *Trends in Parasitology*, vol. 32, no. 4, pp. 296 – 308, 2016.
- [104] Vermeire E., Hearnshaw H., Van Royen P. Denekens J., “Review Article: Patient adherence to treatment: three decades of research. A comprehensive review,” *Journal of Clinical Pharmacy and Therapeutics*, vol. 26, pp. 331–342, 2001.
- [105] Singh O. P., Hasker E., Boelaert M., Sundar S., “Elimination of visceral leishmaniasis on the Indian subcontinent,” *Lancet Infect Dis*, vol. 16, 2016.
- [106] S. DebRoy, O. Prosper, A. Mishoe, and A. Mubayi, “Challenges in modeling complexity of neglected tropical diseases: Assessment of visceral leishmaniasis dynamics in resource limited settings,” *arXiv preprint arXiv:1609.00788*, 2016.
- [107] O. Diekmann, J. Heesterbeek, and M. G. Roberts, “The construction of next-generation matrices for compartmental epidemic models,” *Journal of the Royal Society Interface*, vol. 7, no. 47, pp. 873–885, 2010.
- [108] World Health Organization, “Process of validation of elimination of kala-azar as a public health problem in South-East Asia,” *World Health Organization, Regional Office for South-East Asia, New Delhi, India*, pp. 1–39, 2016.
- [109] Singh S. P., Reddy D. C., Rai M., Sundar S., “Serious underreporting of Visceral Leishmaniasis through passive case reporting in Bihar, India,” *Trop Med Int Health*, vol. 11, no. 6, pp. 899–905, 2006.
- [110] Hirve S., Boelaert M., Matlashewski G., Mondal D., Arana B., Kroeger A., Olliaro P., “Transmission Dynamics of Visceral Leishmaniasis in the Indian Subcontinent – A Systematic Literature Review,” *PLoS Negl Trop Dis*, vol. 10, no. 8, 2016.
- [111] J. M. Cohen, D. L. Smith, C. Cotter, A. Ward, G. Yamey, O. J. Sabot, and B. Moonen, “Malaria resurgence: a systematic review and assessment of its causes,” *Malaria journal*, vol. 11, no. 1, p. 122, 2012.

- [112] A. X. Mo, J. Pesce, and B. F. Hall, “Visceral leishmaniasis control and elimination: is there a role for vaccines in achieving regional and global goals?,” *The American journal of tropical medicine and hygiene*, vol. 95, no. 3, pp. 514–521, 2016.
- [113] E. A. Le Rutte, L. A. Chapman, L. E. Coffeng, S. Jervis, E. C. Hasker, S. Dwivedi, M. Karthick, A. Das, T. Mahapatra, I. Chaudhuri, *et al.*, “Elimination of visceral leishmaniasis in the indian subcontinent: a comparison of predictions from three transmission models,” *Epidemics*, vol. 18, pp. 67–80, 2017.
- [114] L. J. Allen, “A primer on stochastic epidemic models: Formulation, numerical simulation, and analysis,” *Infectious Disease Modelling*, vol. 2, no. 2, pp. 128–142, 2017.
- [115] S. M. O’Regan and J. M. Drake, “Theory of early warning signals of disease emergence and leading indicators of elimination,” *Theoretical Ecology*, vol. 6, no. 3, pp. 333–357, 2013.
- [116] S. M. O’Regan, J. W. Lillie, and J. M. Drake, “Leading indicators of mosquito-borne disease elimination,” *Theoretical ecology*, vol. 9, no. 3, pp. 269–286, 2016.
- [117] S. M. O’Regan and D. L. Burton, “How stochasticity influences leading indicators of critical transitions,” *Bulletin of mathematical biology*, vol. 80, no. 6, pp. 1630–1654, 2018.
- [118] P. Das, J. Alvar, and B. Sharma, “Elimination of vl in the indian subcontinent – is it achievable?,” 2014.
- [119] Poché D. M., Poché R. M., Mukherjee S., Franckowiak G. A., Briley L. N., Somers D. J., Garlapati R. B., “Phlebotomine sandfly ecology on the Indian subcontinent: does village vegetation play a role in sandfly distribution in Bihar, India?,” *Medical and veterinary entomology*, vol. 31, no. 2, pp. 207–213, 2017.
- [120] Bucks R. S., Hawkins K., Skinner T. C., Horn S., Seddon P., Horne R., “Adherence to Treatment in Adolescents with Cystic Fibrosis: The Role of Illness Perceptions and Treatment Beliefs,” *Journal of Pediatric Psychology*, vol. 34, no. 8, pp. 893–902, 2009.
- [121] S. Jervis, L. A. Chapman, S. Dwivedi, M. Karthick, A. Das, E. A. Le Rutte, O. Courtenay, G. F. Medley, I. Banerjee, T. Mahapatra, *et al.*, “Variations in visceral leishmaniasis burden, mortality and the pathway to care within bihar, india,” *Parasites & vectors*, vol. 10, no. 1, p. 601, 2017.
- [122] World Bank: Institute for Health Metrics and Evaluation, “Global health data exchange,” Accessed: March 16, 2019. <http://ghdx.healthdata.org/gbd-results-tool>.
- [123] P. Hotez, “Hookworm and poverty,” *J Annals of the New York Academy of Sciences*, vol. 1136, no. 1, pp. 38–44, 2008.

- [124] P. J. Hotez, J. Bethony, M. E. Bottazzi, S. Brooker, and P. Buss, “Hookworm: “the great infection of mankind”,” *PLoS medicine*, vol. 2, no. 3, p. e67, 2005.
- [125] D. Adu-Gyasi, K. P. Asante, M. T. Frempong, D. K. Gyasi, L. F. Iddrisu, L. Ankrah, D. Dosoo, E. Adeniji, O. Agyei, and S. Gyaase, “Epidemiology of soil transmitted Helminth infections in the middle-belt of Ghana, Africa,” *J Parasite Epidemiology Control*, vol. 3, no. 3, 2018.
- [126] “Soil-transmitted helminths infection,” 2017.
- [127] J. C. Dunn, A. A. Bettis, N. Y. Wyine, A. M. M. Lwin, A. Tun, N. S. Maung, and R. M. Anderson, “Soil-transmitted helminth reinfection four and six months after mass drug administration: results from the delta region of myanmar,” *PLoS neglected tropical diseases*, vol. 13, no. 2, p. e0006591, 2019.
- [128] H. C. Lepper, J. M. Prada, E. L. Davis, S. A. Gunawardena, and T. D. Hollingsworth, “Complex interactions in soil-transmitted helminth co-infections from a cross-sectional study in sri lanka,” *Transactions of The Royal Society of Tropical Medicine and Hygiene*, vol. 112, no. 8, pp. 397–404, 2018.
- [129] R. B. Yapi, E. Hürlimann, C. A. Houngbedji, P. B. Ndri, K. D. Silue, G. Soro, F. N. Kouame, P. Vounatsou, T. Fürst, E. K. N’Goran, *et al.*, “Infection and co-infection with helminths and plasmodium among school children in côte d’ivoire: results from a national cross-sectional survey,” *PLoS neglected tropical diseases*, vol. 8, no. 6, 2014.
- [130] S. Kepha, F. Nuwaha, B. Nikolay, P. Gichuki, T. Edwards, E. Allen, S. M. Njenga, C. S. Mwandawiro, and S. J. Brooker, “Epidemiology of coinfection with soil transmitted helminths and plasmodium falciparum among school children in bumula district in western kenya,” *Parasites & vectors*, vol. 8, no. 1, p. 314, 2015.
- [131] Global Burden of Disease Collaborative Network, Seattle, United States: Institute for Health Metrics and Evaluation (IHME), “Global burden of disease study 2017 (gbd 2017) results,” 2018; Accessed March 16, 2019. <http://ghdx.healthdata.org/gbd-results-tool>.
- [132] J. P. Webster, D. H. Molyneux, P. J. Hotez, and A. Fenwick, “The contribution of mass drug administration to global health: past, present and future,” *J Phil. Trans. R. Soc. B*, vol. 369, no. 1645, p. 20130434, 2014.
- [133] J. D. Keenan, P. J. Hotez, A. Amza, N. E. Stoller, B. D. Gaynor, T. C. Porco, and T. M. Lietman, “Elimination and eradication of neglected tropical diseases with mass drug administrations: a survey of experts,” *J PLoS neglected tropical diseases*, vol. 7, no. 12, p. e2562, 2013.
- [134] S. H. Farrell, J. E. Truscott, and R. M. Anderson, “The importance of patient compliance in repeated rounds of mass drug administration (MDA) for the elimination of intestinal helminth transmission,” *J Parasites vectors*, vol. 10, no. 1, p. 291, 2017.

- [135] P. J. Hotez, S. Brooker, J. M. Bethony, M. E. Bottazzi, A. Loukas, and S. Xiao, “Hookworm infection,” *J New England Journal of Medicine*, vol. 351, no. 8, pp. 799–807, 2004.
- [136] World Health Organization, “Ghana Neglected Tropical Disease Masterplan 2013-2017,” tech. rep., 2013.
- [137] O. mondiale de la Santé, W. H. Organization, *et al.*, “Schistosomiasis and soil-transmitted helminthiasis: number of people treated in 2017,” *Weekly Epidemiological Record= Relevé épidémiologique hebdomadaire*, vol. 93, no. 50, pp. 681–692, 2018.
- [138] P. M. Jourdan, P. H. L. Lamberton, A. Fenwick, and D. G. Addiss, “Soil-transmitted helminth infections,” *J The Lancet*, vol. 391, no. 10117, pp. 252–265, 2018.
- [139] H. C. Turner, J. E. Truscott, and R. M. Anderson, “Cost-effectiveness of community-wide treatment for helminthiasis,” *The Lancet Global Health*, vol. 4, no. 3, p. e156, 2016.
- [140] J. E. Truscott, H. C. Turner, S. H. Farrell, and R. M. Anderson, “Soil-transmitted helminths: mathematical models of transmission, the impact of mass drug administration and transmission elimination criteria,” in *Advances in parasitology*, vol. 94, pp. 133–198, Elsevier, 2016.
- [141] R. M. May and R. M. Anderson, “Population biology of infectious diseases: Part ii,” *Nature*, vol. 280, no. 5722, p. 455, 1979.
- [142] N. Croll, R. Anderson, T. Gyorkos, and E. Ghadirian, “The population biology and control of ascaris lumbricoides in a rural community in iran,” *Transactions of the Royal Society of Tropical Medicine and Hygiene*, vol. 76, no. 2, pp. 187–197, 1982.
- [143] R. Anderson and R. May, “Herd immunity to helminth infection and implications for parasite control,” *Nature*, vol. 315, no. 6019, pp. 493–496, 1985.
- [144] R. Anderson and G. Medley, “Community control of helminth infections of man by mass and selective chemotherapy,” *Parasitology*, vol. 90, no. 4, pp. 629–660, 1985.
- [145] G. Medley, H. Guyatt, and D. Bundy, “A quantitative framework for evaluating the effect of community treatment on the morbidity due to ascariasis,” *Parasitology*, vol. 106, no. 2, pp. 211–221, 1993.
- [146] N. C. Lo, I. I. Bogoch, B. G. Blackburn, G. Raso, E. K. N’Goran, J. T. Coulibaly, S. L. Becker, H. B. Abrams, J. Utzinger, and J. R. Andrews, “Comparison of community-wide, integrated mass drug administration strategies for schistosomiasis and soil-transmitted helminthiasis: a cost-effectiveness modelling study,” *J The Lancet Global Health*, vol. 3, no. 10, pp. e629–e638, 2015.

- [147] M. Chan, H. Guyatt, D. A. Bundy, and G. Medley, “The development and validation of an age-structured model for the evaluation of disease control strategies for intestinal helminths,” *Parasitology*, vol. 109, no. 3, pp. 389–396, 1994.
- [148] L. E. Coffeng, R. Bakker, A. Montresor, and S. J. de Vlas, “Feasibility of controlling hookworm infection through preventive chemotherapy: a simulation study using the individual-based wormsims modelling framework,” *Parasites & vectors*, vol. 8, no. 1, p. 541, 2015.
- [149] R. M. Anderson and R. M. May, “Helminth infections of humans: mathematical models, population dynamics, and control,” in *Advances in parasitology*, vol. 24, pp. 1–101, Elsevier, 1985.
- [150] R. M. Anderson and R. M. May, *Infectious diseases of humans: dynamics and control*. Oxford university press, 1992.
- [151] R. M. Anderson, J. E. Truscott, R. L. Pullan, S. J. Brooker, and D. T. Hollingsworth, “How effective is school-based deworming for the community-wide control of soil-transmitted helminths?,” *J PLoS neglected tropical diseases*, vol. 7, no. 2, p. e2027, 2013.
- [152] W. S.-T. Helminthiasis, “Eliminating soil-transmitted helminthiasis as a public health problem in children,” *Progress Report*, vol. 2010, pp. 2011–2020, 2001.
- [153] H. C. Turner, J. Toor, D. T. Hollingsworth, and R. M. Anderson, “Economic evaluations of mass drug administration: The importance of economies of scale and scope,” *J Clinical Infectious Diseases*, vol. 66, no. 8, pp. 1298–1303, 2017.
- [154] A. M. Gray, P. M. Clarke, J. L. Wolstenholme, and S. Wordsworth, *Applied methods of cost-effectiveness analysis in healthcare*, vol. 3. Oxford University Press, 2011.
- [155] S. Tay, W. Twum, H. Abruquah, *et al.*, “Epidemiological survey of soil-transmitted helminths in occupational risk groups and non school going children in the kintampo north district of ghana,” *Journal of the Ghana Science Association*, vol. 12, no. 2, pp. 86–94, 2010.
- [156] R. J. S. Magalhaes, N.-K. Biritwum, J. O. Gyapong, S. Brooker, Y. Zhang, L. Blair, A. Fenwick, and A. C. Clements, “Mapping helminth co-infection and co-intensity: geostatistical prediction in ghana,” *PLoS neglected tropical diseases*, vol. 5, no. 6, p. e1200, 2011.
- [157] L. E. Coffeng, J. E. Truscott, S. H. Farrell, H. C. Turner, R. Sarkar, G. Kang, S. J. de Vlas, and R. M. Anderson, “Comparison and validation of two mathematical models for the impact of mass drug administration on ascaris lumbricoides and hookworm infection,” *Epidemics*, vol. 18, pp. 38 – 47, 2017. Multi-model comparisons for neglected tropical diseases - validation and projection.

- [158] F. Fleming, L. C. Rodrigues, S. Brooker, A. Jardim-Botelho, I. R. Caldas, R. Correa-Oliveira, J. M. Bethony, S. M. Geiger, R. J. Quinnell, and P. J. Hotez, “Age-related changes in hookworm infection, anaemia and iron deficiency in an area of high *Necator americanus* hookworm transmission in south-eastern Brazil,” *Transactions of The Royal Society of Tropical Medicine and Hygiene*, vol. 101, pp. 146–154, 02 2007.
- [159] J. E. Truscott, D. T. Hollingsworth, S. J. Brooker, and R. M. Anderson, “Can chemotherapy alone eliminate the transmission of soil transmitted helminths?,” *J Parasites vectors*, vol. 7, no. 1, p. 266, 2014.
- [160] T. P. for Child Development, “The cost of large-scale school health programmes which deliver anthelmintics to children in Ghana and Tanzania,” *Acta Tropica*, vol. 73, no. 2, pp. 183 – 204, 1999.
- [161] H. C. Turner, M. Y. Osei-Atweneboana, M. Walker, E. J. Tettevi, T. S. Churcher, O. Asiedu, N.-K. Biritwum, and M.-G. Basáñez, “The cost of annual versus biannual community-directed treatment of onchocerciasis with ivermectin: Ghana as a case study,” *J PLoS neglected tropical diseases*, vol. 7, no. 9, p. e2452, 2013.
- [162] J. Keiser and J. Utzinger, “Efficacy of current drugs against soil-transmitted helminth infections: systematic review and meta-analysis,” *Jama*, vol. 299, no. 16, pp. 1937–1948, 2008.
- [163] World Health Organization et. al., *Preventive chemotherapy in human helminthiasis. Coordinated use of anthelmintic drugs in control interventions: a manual for health professionals and programme managers*. World Health Organization, 2006.
- [164] Central Intelligence Agency, “The world factbook: Africa::ghana,” 2018 (Accessed March 16, 2019). https://www.cia.gov/library/publications/the-world-factbook/geos/print_gh.html.
- [165] The Partnership for Child Development, “The cost of large-scale school health programmes which deliver anthelmintics to children in Ghana and Tanzania,” *J Acta Tropica*, vol. 73, no. 2, pp. 183–204, 1999.
- [166] R. S. Bradbury and P. M. Graves, “Current WHO protocols for mass drug administration in helminth control,” *J Microbiology Australia*, vol. 37, no. 1, pp. 10–12, 2016.
- [167] F. Tajebe, M. Getahun, E. Adem, A. Hailu, M. Lemma, H. Fikre, J. Raynes, A. Tamiru, Z. Mulugeta, E. Diro, F. Toulza, Z. Shkedy, T. Ayele, M. Modolell, M. Munder, I. Müller, Y. Takele, and P. Kropf, “Disease severity in patients with visceral leishmaniasis is not altered by co-infection with intestinal parasites,” *PLOS Neglected Tropical Diseases*, vol. 11, no. 7, p. e0005727, 2017.

- [168] D. Mupfasoni, M. Bangert, A. Mikhailov, C. Marocco, and A. Montresor, “Sustained preventive chemotherapy for soil-transmitted helminthiases leads to reduction in prevalence and anthelmintic tablets required,” *Infectious diseases of poverty*, vol. 8, no. 1, p. 82, 2019.
- [169] R. M. Anderson and R. M. May, “Population dynamics of human helminth infections: control by chemotherapy,” *J Nature*, vol. 297, no. 5867, p. 557, 1982.
- [170] N. de Silva and A. Hall, “Using the prevalence of individual species of intestinal nematode worms to estimate the combined prevalence of any species,” *PLoS neglected tropical diseases*, vol. 4, no. 4, 2010.
- [171] H. C. Turner, M. Walker, T. S. Churcher, M. Y. Osei-Atweneboana, N.-K. Biritwum, A. Hopkins, R. K. Prichard, and M.-G. Basáñez, “Reaching the london declaration on neglected tropical diseases goals for onchocerciasis: an economic evaluation of increasing the frequency of ivermectin treatment in africa,” *Clinical Infectious Diseases*, vol. 59, no. 7, pp. 923–932, 2014.
- [172] M. Kretzschmar, “Disease modeling for public health: added value, challenges, and institutional constraints,” *Journal of public health policy*, vol. 41, no. 1, pp. 39–51, 2020.
- [173] M. Keeling and L. Danon, “Mathematical modelling of infectious diseases.,” *British Medical Bulletin*, vol. 92, no. 1, 2009.
- [174] S. B. Kim, M. Yoon, N. S. Ku, M. H. Kim, J. E. Song, J. Y. Ahn, S. J. Jeong, C. Kim, H.-D. Kwon, J. Lee, *et al.*, “Mathematical modeling of hiv prevention measures including pre-exposure prophylaxis on hiv incidence in south korea,” *PloS one*, vol. 9, no. 3, 2014.
- [175] A. Huppert and G. Katriel, “Mathematical modelling and prediction in infectious disease epidemiology,” *Clinical microbiology and infection*, vol. 19, no. 11, pp. 999–1005, 2013.
- [176] K. Bi, Y. Chen, S. Zhao, Y. Kuang, and C.-H. John Wu, “Current visceral leishmaniasis research: a research review to inspire future study,” *BioMed research international*, vol. 2018, 2018.
- [177] G. Greene, R. W. Costello, B. Cushen, I. Sulaiman, E. Mac Hale, R. M. Conroy, and F. Doyle, “A novel statistical method for assessing effective adherence to medication and calculating optimal drug dosages,” *PloS one*, vol. 13, no. 4, 2018.
- [178] A. Schlender, P. E. Alperin, H. L. Grossman, and E. R. Sutherland, “Modeling the impact of increased adherence to asthma therapy,” *PLoS One*, vol. 7, no. 12, 2012.
- [179] J. M. D. A. Simones, *An agent-based approach to spatial epidemics through GIS*. University of London, University College London (United Kingdom), 2007.

- [180] P. Stroud, S. Del Valle, S. Sydoriak, J. Riese, and S. Mniszewski, “Spatial dynamics of pandemic influenza in a massive artificial society,” *Journal of Artificial Societies and Social Simulation*, vol. 10, no. 4, p. 9, 2007.
- [181] C. L. Barrett, K. R. Bisset, S. G. Eubank, X. Feng, and M. V. Marathe, “EpiSimdemics: an efficient algorithm for simulating the spread of infectious disease over large realistic social networks,” in *High Performance Computing, Networking, Storage and Analysis, 2008. SC 2008. International Conference for*, pp. 1–12, IEEE, 2008.
- [182] S. M. Mniszewski, S. Y. Del Valle, P. D. Stroud, J. M. Riese, and S. J. Sydoriak, “Episims simulation of a multi-component strategy for pandemic influenza,” in *Proceedings of the 2008 Spring simulation multiconference*, pp. 556–563, Society for Computer Simulation International, 2008.
- [183] L. Perez and S. Dragicevic, “An agent-based approach for modeling dynamics of contagious disease spread,” *International journal of health geographics*, vol. 8, no. 1, p. 50, 2009.
- [184] E. Hunter, B. Mac Namee, and J. Kelleher, “Correction: An open-data-driven agent-based model to simulate infectious disease outbreaks,” *PloS one*, vol. 14, no. 1, p. e0211245, 2019.
- [185] A. Plaisier, G. Van Oortmarsen, J. Habbema, J. Remme, and E. Alley, “Onchosim: a model and computer simulation program for the transmission and control of onchocerciasis,” *Computer methods and programs in biomedicine*, vol. 31, no. 1, pp. 43–56, 1990.
- [186] S. De Vlas, G. Van Oortmarsen, B. Gryseels, A. Polderman, A. Plaisier, and J. Habbema, “Schistosim: a microsimulation model for the epidemiology and control of schistosomiasis,” *The American journal of tropical medicine and hygiene*, vol. 55, no. 5_Suppl, pp. 170–175, 1996.
- [187] J. Bedford, J. Farrar, C. Ihekweazu, G. Kang, M. Koopmans, and J. Nkengasong, “A new twenty-first century science for effective epidemic response,” *Nature*, vol. 575, no. 7781, pp. 130–136, 2019.
- [188] P. Fine, C. G. Victora, K. J. Rothman, P. S. Moore, Y. Chang, V. Curtis, D. L. Heymann, G. Slutkin, R. M. May, V. Patel, *et al.*, “John snow’s legacy: epidemiology without borders,” *The Lancet*, vol. 381, no. 9874, pp. 1302–1311, 2013.
- [189] J. D. Munday, A. J. van Hoek, W. J. Edmunds, and K. E. Atkins, “Quantifying the impact of social groups and vaccination on inequalities in infectious diseases using a mathematical model,” *BMC medicine*, vol. 16, no. 1, p. 162, 2018.
- [190] C. Orbann, L. Sattenspiel, E. Miller, and J. Dimka, “Defining epidemics in computer simulation models: How do definitions influence conclusions?,” *Epidemics*, vol. 19, pp. 24–32, 2017.

- [191] J. Reis and P. S. Spencer, “Decision-making under uncertainty in environmental health policy: new approaches,” *Environmental health and preventive medicine*, vol. 24, no. 1, pp. 1–8, 2019.
- [192] M. Burkhardt, “Estimating possibly undetected covid-19 infection cases,” 2020.
- [193] N. I. o. G. M. S. N. NIH, “What is computer modeling and how does it work?.”
- [194] C. I. Anumudu, O. S. Onile, H. Awobode, A. Gboyega-Tokunbo, V. Oladele, A. Adebayo, and C. O. Chouvwun, “Socio-cultural and environmental determinants of a proposed schistosomiasis health education intervention in eggua, nigeria,” 2019.
- [195] H. T. Melkamu, A. M. Beyene, and D. T. Zegeye, “Knowledge, attitude and practices of the resident community about visceral leishmaniasis in west aramchiho district, northwest ethiopia,” *Heliyon*, vol. 6, no. 1, p. e03152, 2020.
- [196] A. Price, A. Verma, and W. Welfare, “Are health education interventions effective for the control and prevention of urogenital schistosomiasis in sub-saharan africa? a systematic review,” *Transactions of The Royal Society of Tropical Medicine and Hygiene*, vol. 109, no. 4, pp. 239–244, 2015.
- [197] B. A. Israel, A. J. Schulz, E. A. Parker, and A. B. Becker, “Review of community-based research: assessing partnership approaches to improve public health,” *Annual review of public health*, vol. 19, no. 1, pp. 173–202, 1998.
- [198] N. A. Jones, P. Perez, T. G. Measham, G. J. Kelly, P. d’Aquino, K. A. Daniell, A. Dray, and N. Ferrand, “Evaluating participatory modeling: developing a framework for cross-case analysis,” *Environmental management*, vol. 44, no. 6, p. 1180, 2009.
- [199] G. A. Mendoza and R. Prabhu, “Participatory modeling and analysis for sustainable forest management: Overview of soft system dynamics models and applications,” *Forest Policy and Economics*, vol. 9, no. 2, pp. 179–196, 2006.
- [200] L. M. Whiteford and C. Vindrola-Padros, *Community participatory involvement: A sustainable model for global public health*. Left Coast Press, 2015.
- [201] J. D. Mbako, D. Barffo, R. K. Nuotol, R. Alebshehy, and N. M. Shuaib, “Enhancing malaria prevention in cameroon through community participation: an in-depth review,” *Central African Journal of Public Health*, vol. 3, no. 6, p. 97, 2017.
- [202] M. Brear, K. Hammarberg, and J. Fisher, “Community participation in research from resource-constrained countries: a scoping review,” *Health Promotion International*, vol. 33, no. 4, pp. 723–733, 2018.
- [203] B. B. Brown, “Delphi process: a methodology used for the elicitation of opinions of experts,” tech. rep., Rand Corp Santa Monica CA, 1968.
- [204] World Health Organization, “Leishmaniasis.”

- [205] Brauer F., Castillo-Chavez C., *Mathematical models in population biology and epidemiology*, vol. 40. Springer, 2012.
- [206] Diekmann O., Heesterbeek J. A. P., Roberts M. G., “The construction of next-generation matrices for compartmental epidemic models,” *Journal of the Royal Society Interface*, vol. 7, no. 47, pp. 873–885, 2009.
- [207] C. Castillo-Chavez and B. Song, “Dynamical models of tuberculosis and their applications,” *Mathematical biosciences and engineering*, vol. 1, no. 2, pp. 361–404, 2004.
- [208] de León C. V., Hernández J. A. C., “Local and Global Stability of Host-Vector Disease Models,” *Foro-Red-Mat: Revista electrónica de contenido matemático*, vol. 25, no. 3, pp. 1–8, 2008.
- [209] J. G. Ayisi, A. H. van’t Hoog, J. A. Agaya, W. Mchembere, P. O. Nyamthimba, O. Muhenje, and B. J. Marston, “Care seeking and attitudes towards treatment compliance by newly enrolled tuberculosis patients in the district treatment programme in rural western kenya: a qualitative study,” *BMC public health*, vol. 11, no. 1, p. 515, 2011.
- [210] F. für Internationale Tuberkulosehilfe, “Treatment default.” Accessed March, 2019.
- [211] I. Cherkaoui, R. Sabouni, D. Kizub, A. C. Billieux, K. Bennani, J. E. Bourkadi, A. Benmamoun, O. Lahlou, R. El Aouad, and K. E. Dooley, “Treatment default amongst patients with tuberculosis in urban morocco: predicting and explaining default and post-default sputum smear and drug susceptibility results,” *PloS one*, vol. 9, no. 4, p. e93574, 2014.
- [212] S. Funk, M. Salathé, and V. A. A. Jansen, “Modelling the influence of human behaviour on the spread of infectious diseases: a review,” *Journal of The Royal Society Interface*, vol. 7, no. 50, pp. 1247–1256, 2010.
- [213] A. Rondags, A. B. Himawan, J. F. Metsemakers, and T. N. Kristina, “Factors influencing non-adherence to tuberculosis treatment in jepara, central java, indonesia,” *Southeast Asian Journal of Tropical Medicine and Public Health*, vol. 45, no. 4, p. 859, 2014.
- [214] L. C. Plantinga, L. E. Boulware, J. Coresh, L. A. Stevens, I. Miller, Edgar R., R. Saran, K. L. Messer, A. S. Levey, and N. R. Powe, “Patient Awareness of Chronic Kidney Disease: Trends and Predictors,” *Archives of Internal Medicine*, vol. 168, pp. 2268–2275, 11 2008.
- [215] V. Goyal, R. Mahajan, K. Pandey, S. N. Singh, R. S. Singh, N. Strub-Wourgaft, F. Alves, V. N. R. Das, R. K. Topno, B. Sharma, *et al.*, “Field safety and effectiveness of new visceral leishmaniasis treatment regimens within public health facilities in bihar, india,” *PLoS neglected tropical diseases*, vol. 12, no. 10, p. e0006830, 2018.

- [216] A. Croft, N. Taylor, and K. Rodenhurst, "Sandflies and leishmaniasis," *The Lancet*, vol. 367, no. 9505, p. 112, 2006.
- [217] B. Water resources department, "Flood management information system: Flood history," Accessed March, 2019.

APPENDIX A

VL SYMPTOMS AND TREATMENT NON-ADHERENCE DATA

Health facility	Population	Total Treated	Treatment not completed	Ratio
Siraha Dits Hosp Lahan	637,328	36	1	0.027778
Kudhani PHC	10,461	63	6	0.095238
Kanti PHC	20,873	76	9	0.118421
Motipur PHC	28,572	107	20	0.186916
Jaleswor distr Hosp	23533	115	16	0.13913
BPKIHS Dharan	119,915	151	9	0.059603
KAMRC Muzzafarpur	354,462	468	9	0.019231
Total	1,195,144	1016	70	0.068898

Table A.1: Data from (4) for Health-Facility Wise Treatment Non-Adherence and VL Prevalence

The common symptoms of VL are fever, malaise, shivering or chills, weight loss, anorexia and discomfort in the left hypochondrium, and infections like pneumonia, dysentery and tuberculosis in the advanced stages resulting in their death. Darkening of the skin of the face, hands, feet and abdomen is typically found in India. The infection affects spleen, liver, lymph nodes and small-intestine tissues causing a drastic reduction in the leukocyte and erythrocyte count resulting in anemia and immuno-deficiency. This paper mainly focuses on spread and control of VL in Bihar, India because it is estimated that 90% VL cases of India are from Bihar (1). According to WHO, the major risk factors for the spread of VL are population mobility, socioeconomic conditions, climate change, environmental changes and malnutrition (2). The other risk factors for VL in India are the houses are frequently constructed with mud walls and earthen floors, and cattle and other livestock live close to humans where the disease is most common in villages (3).

REFERENCES

- [1] S. S. Singh R. K., Pandey H. P., “Visceral leishmaniasis (kala-azar): challenges ahead,”
- [2] World Health Organization, “Leishmaniasis.”
- [3] National Vector Borne Disease Control Programme: WHO country office for India, “Accelerated Plan for Kala-azar Elimination 2017,” http://www.who.int/leishmaniasis/resources/Accelerated-Plan-Kala-azar1-Feb2017_light.pdf?ua=1.
- [4] Ostyn B., Hasker E., Dorlo T. P. C., Rijal S., Sundar S., Dujardin J.-C., Boelaert M., “Failure of Miltefosine Treatment for Visceral Leishmaniasis in Children and Men in South-East Asia,” *PLOS ONE*, vol. 9, pp. 1–8, 06 2014.

APPENDIX B

MATHEMATICAL ANALYSIS FOR THE MODEL IN CHAPTER 2

Model analysis

Well-posedness and dissipativity

The disease is assumed to take the course as explained in the model description. Differentiation with respect to time will be denoted by a prime, i.e. $' = d/dt$. Since $S'_H \geq 0$ if $S_H = 0$, $I'_H \geq 0$ if $I_H = 0$, $T'_H \geq 0$ if $T_H = 0$, $R'_H \geq 0$ if $R_H = 0$, $S'_V \geq 0$ if $S_V = 0$ and $I'_V \geq 0$ if $I_V = 0$, we have $S_H \geq 0, I_H \geq 0, T_H \geq 0, R_H \geq 0, S_V \geq 0$ and $I_V \geq 0$ for $t \geq 0$. Let $N_H = S_H + I_H + T_H + R_H$ and $N_V = S_V + I_V$. Since $N'_H = \Lambda_H - \mu_H N_H - \delta I_H \leq 0$ if $N_H = \Lambda_H/\mu_H$, we have $N_H \leq \Lambda_H/\mu_H$ for $t \geq 0$. Similarly, since $N'_V = \Lambda_V - \mu_V N_V \leq 0$ if $N_V = \Lambda_V/\mu_V$, we have $N_V \leq \Lambda_V/\mu_V$ for $t \geq 0$. Thus the solution will always remain in the biologically realistic region $\Omega = \{(S_H, I_H, T_H, R_H, S_V, I_V) \in \mathbb{R}_+^6 \mid 0 \leq N_H \leq \Lambda_H/\mu_H, 0 \leq N_V \leq \Lambda_V/\mu_V\}$ (where \mathbb{R}_+ denotes the non-negative real space) if it starts in this region (1).

If $N_H = K_H > \Lambda_H/\mu_H$ and if $N_V = K_V > \Lambda_V/\mu_V$ then $N'_H < 0$ and $N'_V < 0$ respectively. This shows that the solution approaches Ω and asymptotically be in the biologically realistic region $\{(S_H, I_H, T_H, R_H, S_V, I_V) \in \mathbb{R}_+^6 \mid 0 \leq N_H \leq K_H, 0 \leq N_V \leq K_V\}$ since S_H, I_H, T_H, R_H are bounded above by N_H and S_V, I_V are bounded above by N_V . Therefore, the system (2.1) is dissipative since the solutions are non-negative and uniformly eventually bounded (as defined in (2)).

Furthermore, the above results satisfy the assumptions of *Theorem A.4* in (2), thus we can assert that for every $(S_H^0, I_H^0, T_H^0, R_H^0, S_V^0, I_V^0) \in \mathbb{R}_+^6$, there exists a unique solution of 2.1, $S_H(0) = S_H^0, I_H(0) = I_H^0, T_H(0) = T_H^0, R_H(0) = R_H^0, S_V(0) = S_V^0, I_V(0) = I_V^0$, with values in \mathbb{R}_+^6 , which is defined on an interval $[0, \max\{N_H(0), N_V(0)\})$. Therefore, the system 2.1 is well-posed.

Control reproduction number (R_c)

To compute R_c , we compute the next-generation matrix (3; 4) by considering the infecting compartments I_H, T_H and I_V . First let the vector $x = (S_H, T_H, I_V)$ such that $x' = \mathcal{F} - \mathcal{V}$ where

$$\mathcal{F} = \begin{bmatrix} \frac{b\beta_{VH}S_H I_V}{S_H + I_H + T_H + R_H} \\ 0 \\ \frac{b\beta_{HV}S_V(I_H + \alpha T_H)}{S_H + I_H + T_H + R_H} \end{bmatrix} \quad \mathcal{V} = \begin{bmatrix} \gamma I_H - \theta(1 - \phi)T_H + (\delta + \mu_H)I_H \\ -\gamma I_H + \theta T_H + \mu_H T_H \\ \mu_V I_V \end{bmatrix}$$

$F = \frac{\partial \mathcal{F}}{\partial x}$ and $\frac{\partial \mathcal{V}}{\partial x}$ evaluated at the DFE are as follows

$$F = \begin{bmatrix} 0 & 0 & b\beta_{VH} \\ 0 & 0 & 0 \\ \frac{b\beta_{HV}\Lambda_V/\mu_V}{\Lambda_H/\mu_H} & \frac{\alpha b\beta_{HV}\Lambda_V/\mu_V}{\Lambda_H/\mu_H} & 0 \end{bmatrix}$$

$$V = \begin{bmatrix} \gamma + \delta + \mu_H & -\theta(1 - \phi) & 0 \\ -\gamma & \theta + \mu_H & 0 \\ 0 & 0 & -\mu_V \end{bmatrix}$$

Therefore, R_c will be the spectral radius of FV^{-1} where

$$FV^{-1} = \begin{bmatrix} 0 & 0 & -\frac{b\beta_{VH}}{\mu_V} \\ 0 & 0 & 0 \\ \frac{b\beta_{HV}\Lambda_V\mu_H(\alpha\gamma+\theta+\mu_H)}{\Lambda_H\mu_V(\gamma(\theta\phi+\mu_H)+(\delta+\mu_H)(\theta+\mu_H))} & \frac{b\beta_{HV}\Lambda_V\mu_H(\alpha(\gamma+\delta+\mu_H)+\theta(1-\phi))}{\Lambda_H\mu_V(\gamma(\theta\phi+\mu_H)+(\delta+\mu_H)(\theta+\mu_H))} & 0 \end{bmatrix}$$

$$R_c^2 = \frac{b^2\beta_{VH}\beta_{HV}\Lambda_V\mu_H\left(\frac{\alpha\gamma}{\theta+\mu_H} + 1\right)}{\Lambda_H\mu_V^2(\delta + \mu_H + \gamma\left(\frac{\theta\phi+\mu_h}{\theta+\mu_H}\right))} \quad (\text{B.1})$$

Local stability of the equilibria:

Theorem The DFE is locally asymptotically stable if $R_{c1}^2 < 1$ and unstable if $R_{c1}^2 > 1$.

Proof. To prove the first part of the theorem, we compute the Jacobian matrix of the reduced system 2.4 and evaluate it at the DFE.

$$J|_{DFE} = \begin{bmatrix} -\mu_H & 0 & 0 & -b\beta_{VH} \\ 0 & -\gamma - \mu_H - \delta & \theta(1 - \phi) & b\beta_{VH} \\ 0 & \gamma & -\theta - \mu_H & 0 \\ 0 & b\beta_{HV}\Lambda_V\mu_h/(\Lambda_H\mu_V) & \alpha b\beta_{HV}\Lambda_V\mu_h/(\Lambda_H\mu_V) & -\mu_V \end{bmatrix}$$

The trace of this matrix is negative. The determinant of this matrix is

$$\Delta = -\frac{\mu_H^2(\theta + \mu_H)}{\Lambda_H^2\mu_V^2(\mu_H + \delta + \gamma\left(1 + \frac{\theta(1-\phi)}{\theta+\mu_H}\right))}(R_c^2 - 1)$$

Hence, Δ is positive if $R_c^2 < 1$ thus implying local asymptotic stability of the DFE since all eigenvalues will be strictly negative and DFE is unstable if $R_{c1}^2 > 1$.

Note: For $\delta = 0$, host population is constant and that the EE exists if and only if $R_{c1}^2 (= R_c^2(\delta = 0)) > 1$ and from above EE will be locally asymptotically stable. \square

Backward bifurcation

Theorem: The model (2.1) undergoes a backward bifurcation at $R_c = 1$ if the per capita rate of mortality due to VL is sufficiently large. Specifically,

$$\delta > \frac{1}{\mu_V}(\mu_H(2\mu_V + b\beta_{HV}N_V) + \gamma(2\mu_V\frac{\theta\phi + \mu_H}{\theta + \mu_H} + b\beta_{HV}N_V\frac{\mu_H}{\theta + \mu_H}))$$

Proof. In the system 2.1, we saw that the vector population $N_V = S_V + I_V$ was constant. Therefore, we substitute $S_V = N_V - I_V$ in 2.1 to work with the system of only 5 equations. The Jacobian of this new system, evaluated at the DFE is

$$J^* = \begin{bmatrix} -\mu_H & 0 & 0 & 0 & -b\beta_{VH} \\ 0 & -(\gamma + \delta + \mu_H) & \theta(1 - \phi) & 0 & b * \beta_{VH} \\ 0 & \gamma & -(\theta + \mu_H) & 0 & 0 \\ 0 & 0 & \theta\phi & -\mu_H & 0 \\ 0 & b\beta_{HV}N_V\mu_H/\Lambda_H & \alpha b\beta_{HV}N_V\mu_H/\Lambda_H & 0 & -\mu_V \end{bmatrix}$$

The right eigenvector of J^* corresponding to the zero eigenvalue is given by $w = [w_1, w_2, w_3, w_4, w_5]^T$ such that,

$$\begin{aligned}
w_1 &= -\frac{b\beta_{VH}}{\mu_H}w_5 \\
w_2 &= \frac{b\beta_{VH}}{\gamma + \delta + \mu_H - \frac{\theta\gamma(1-\phi)}{\theta+\mu_H}}w_5 \\
w_3 &= \frac{\gamma}{\theta + \mu_H}w_2 = \frac{\gamma}{\theta + \mu_H} \frac{b\beta_{VH}}{\gamma + \delta + \mu_H - \frac{\theta\gamma(1-\phi)}{\theta+\mu_H}}w_5 \\
w_4 &= \frac{\theta\phi}{\mu_H}w_3 = \frac{\theta\phi}{\mu_H} \frac{\gamma}{\theta + \mu_H} \frac{b\beta_{VH}}{\gamma + \delta + \mu_H - \frac{\theta\gamma(1-\phi)}{\theta+\mu_H}}w_5 \\
w_5 &= w_5
\end{aligned}$$

The left eigenvector of J^* corresponding to the zero eigenvalue is given by $v = [v_1, v_2, v_3, v_4, v_5]$ such that,

$$\begin{aligned}
v_1 &= 0 \\
v_2 &= \frac{\mu_V}{b\beta_{VH}}v_5 \\
v_3 &= (b\beta_{HV}N_V \frac{\mu_H}{\Lambda_H} - \frac{\mu_V}{b\beta_{VH}}(\gamma + \delta + \mu_H))v_5 \\
v_4 &= 0 \\
v_5 &= v_5
\end{aligned}$$

Then,

$$A = \sum_{k,i,j=1}^5 v_k w_i w_j \frac{\partial^2 f_k}{\partial x_i \partial x_j}$$

is calculated and evaluated at the DFE. Here, $(f_1, f_2, f_3, f_4, f_5) = (S'_H, I'_H, T'_H, R'_H, I'_V)$ and $(x_1, x_2, x_3, x_4, x_5) = (S_H, I_H, T_H, R_H, I_V)$. Smoothness of the system (since it is polynomial-like) implies that the second derivatives are symmetric i.e. for any smooth function f , $\partial_{xy}f = \partial_{yx}f$ by Schwartz's theorem. Therefore, the associated non-zero second derivatives evaluated at the DFE are as follows

$$\begin{aligned}
\frac{\partial^2 f_2}{\partial x_2 \partial x_5} &= \frac{\partial^2 f_2}{\partial x_3 \partial x_5} = \frac{\partial^2 f_2}{\partial x_4 \partial x_5} = -\frac{b\beta_{VH}\mu_H}{\Lambda_H} \\
\frac{\partial^2 f_5}{\partial x_1 \partial x_2} &= \frac{1}{2} \frac{\partial^2 f_5}{\partial x_2 \partial x_2} = \frac{\partial^2 f_5}{\partial x_2 \partial x_4} = -\frac{b\beta_{HV}N_V\mu_H^2}{\Lambda_H^2} \\
\frac{\partial^2 f_5}{\partial x_1 \partial x_3} &= \frac{1}{2} \frac{\partial^2 f_5}{\partial x_3 \partial x_3} = \frac{\partial^2 f_5}{\partial x_3 \partial x_4} = -\frac{\alpha b\beta_{HV}N_V\mu_H^2}{\Lambda_H^2} \\
\frac{\partial^2 f_5}{\partial x_2 \partial x_3} &= -\frac{(1+\alpha)b\beta_{HV}N_V\mu_H^2}{\Lambda_H^2} \\
\frac{\partial^2 f_5}{\partial x_2 \partial x_5} &= -\frac{b\beta_{VH}\mu_H}{\Lambda_H} \\
\frac{\partial^2 f_5}{\partial x_3 \partial x_5} &= -\frac{\alpha b\beta_{VH}\mu_H}{\Lambda_H}
\end{aligned}$$

In the expression of A , we substitute $\beta_{VH} = \frac{\Lambda_H \mu_V^2 (\delta + \mu_H + \gamma (\frac{\theta\phi + \mu_H}{\theta + \mu_H}))}{b^2 \beta_{HV} \Lambda_V \mu_H (\frac{\alpha\gamma}{\theta + \mu_H} + 1)}$ using the assumption $R_c = 1$. Therefore A is

$$A = - \frac{\mu_V (-2\delta\mu_V + \mu_H (2\mu_V + b\beta_{HV} N_V)) + \gamma (\frac{2\mu_V (\mu_H + \theta\phi)}{\mu_H + \theta} + \frac{b\beta_{HV} \mu_H N_V}{\mu_H + \theta})}{b\beta_{HV} \mu_H N_V (1 + \frac{\gamma\alpha}{\mu_H + \theta})}$$

$$\implies A > 0 \iff \delta > \frac{1}{\mu_V} (\mu_H (2\mu_V + b\beta_{HV} N_V) + \gamma (2\mu_V \frac{\theta\phi + \mu_H}{\theta + \mu_H} + b\beta_{HV} N_V \frac{\mu_H}{\theta + \mu_H}))$$

Next,

$$B = \sum_{k,i=1}^5 v_k w_i \frac{\partial^2 f_k}{\partial x_i \partial \delta}$$

is calculated and evaluated at the DFE where δ is the chosen parameter for bifurcation. Here f_i and x_i for $i = 1, 2, \dots, 5$ are same as defined above. The only non-zero second derivative obtained is

$$\frac{\partial^2 f_2}{\partial x_2 \partial \delta} = 1$$

Therefore,

$$\begin{aligned} B &= v_2 w_2 \frac{\partial^2 f_2}{\partial x_2 \partial \delta} \\ &= \frac{\mu_V (\theta + \mu_H)}{(\delta + \mu_H)(\theta + \mu_H) + \gamma(\theta\phi + \mu_H)} v_5 w_5 \\ &> 0 \end{aligned}$$

Using Castillo-Chavez and Song theorem (2004) and Theorem 4.2 from (5), we assert that our system undergoes backward bifurcation when $R_c = 1$ if

$$\delta > \frac{1}{\mu_V} (\mu_H (2\mu_V + b\beta_{HV} N_V) + \gamma (2\mu_V \frac{\theta\phi + \mu_H}{\theta + \mu_H} + b\beta_{HV} N_V \frac{\mu_H}{\theta + \mu_H}))$$

□

Global stability of the DFE

Theorem If $R_{c2}^2 < 1$, then the DFE for the models 2.4 and 2.7 is globally asymptotically stable in the positively invariant and attracting region Ω .

Proof. For model 2.4:

Define the Lyapunov function as follows in terms of the infected compartments (6; 7) $U : \{I_H, T_H, I_V\} \in \Omega : I_H, T_H, I_V > 0\} \longrightarrow \mathbb{R}$ by

$$U(I_H, T_H, I_V) = c_1 I_H + c_2 T_H + c_3 I_V$$

such that $c_1, c_2, c_3 > 0$ and

$$c_2 = \frac{\theta(1 - \phi)}{\theta + \mu_H} c_1 \tag{B.2}$$

$$c_3 = \frac{b\beta_{VH}}{\mu_V} c_1 \tag{B.3}$$

The time derivative of U computed along solutions of the system is

$$\begin{aligned} U' &= c_1 I_H' + c_2 T_H' + c_3 I_V' \\ &= c_1 (b\beta_{VH} S_H \frac{I_V}{N_H} - \gamma I_H + \theta(1 - \phi) T_H - \mu_H I_H) + c_2 (\gamma I_H - \theta T_H - \mu_H T_H) \\ &\quad + c_3 (b\beta_{HV} (N_V - I_V) \frac{I_H + \alpha T_H}{N_H} - \mu_V I_V) \end{aligned}$$

Substituting the expression of c_2 from B.2, the T_H terms vanish. Further substituting the expression of c_3 from B.3, we get:

$$U' = U_1 + U_2$$

where,

$$\begin{aligned} U_1 &= c_1 b\beta_{VH} \frac{I_V}{N_H} (-N_H + S_H \frac{I_H}{\mu_V}) \\ &< 0 \end{aligned}$$

and

$$U_2 = c_1 (\mu_H + \frac{\gamma(\theta\phi + \mu_H)}{\theta + \mu_H}) (R_{c_2}^2 - 1)$$

$$U' = U_1 + U_2 < 0 \iff U_2 < 0 \iff R_{c_2}^2 < 1$$

LaSalle's invariant principle then implies that DFE is globally asymptotically stable in Ω (7).

For model 2.7: For this system, define the Lyapunov function as follows in terms of the infected compartments $L : \{I_H, T_H \in \Omega : I_H, T_H > 0\} \rightarrow \mathbb{R}$ by

$$L(I_H, T_H) = \tilde{c}_1 I_H + \tilde{c}_2 T_H$$

such that $\tilde{c}_1, \tilde{c}_2 > 0$ and

$$\tilde{c}_2 = \frac{\theta(1 - \phi)}{\theta + \mu_H} \tilde{c}_1$$

The time derivative of U computed along solutions of the system is

$$\begin{aligned} L' &= \tilde{c}_1 I_H' + \tilde{c}_2 T_H' \\ &= \tilde{c}_1 (b\beta_{VH} S_H \frac{I_V^*}{N_H} - \gamma I_H + \theta(1 - \phi) T_H - \mu_H I_H) + \tilde{c}_2 (\gamma I_H - \theta T_H - \mu_H T_H) \end{aligned}$$

Substituting the expression of \tilde{c}_2 from B.4, the T_H terms vanish. Then,

$$\begin{aligned}
L' &= c_1 I_H \left(\mu_H + \frac{\gamma(\theta\phi + \mu_H)}{\theta + \mu_H} \right) \left(\frac{\mu_V S_H}{\mu_V N_H + b\beta_{HV} I_H} R_{c2}^2 - 1 \right) \\
L' < 0 &\iff \frac{\mu_V S_H}{\mu_V N_H + b\beta_{HV} I_H} R_{c2}^2 < 1 \\
&\iff \mu_V S_H R_{c2}^2 < \mu_V N_H + b\beta_{HV} I_H \\
&\iff \left(\frac{S_H}{N_H} R_{c2}^2 - 1 \right) < \frac{b\beta_{HV} I_H}{\mu_V N_H} \\
&\iff \left(\frac{S_H}{N_H} R_{c2}^2 - 1 \right) - \frac{b\beta_{HV} I_H}{\mu_V N_H} < 0
\end{aligned}$$

Since S_H is bounded above by N_H , the condition $R_{c2}^2 < 1$ is a sufficient condition for $L' < 0$. Thus, for $R_{c2}^2 < 1$, LaSalle's invariant principle implies that DFE is globally asymptotically stable in Ω (7). \square

Uniform persistence of EE

Theorem Let $\tilde{R}_c^2 > 1$. If $Z_H(0) > 0$, $Z_H(t)$ does not converge to zero as $t \rightarrow \infty$ and $S_{H\infty} \leq \frac{N_H}{\tilde{R}_c^2}$.

Preliminaries:

- (a) The method of fluctuations (Proposition A.22 in (2)) states that there exists sequences t_n and s_n such that

$$\begin{aligned}
f(s_n) &\rightarrow f_\infty, f'(s_n) \rightarrow 0 \\
f(t_n) &\rightarrow f^\infty, f'(t_n) \rightarrow 0
\end{aligned}$$

for $n \rightarrow \infty$.

- (b) Using the Proposition in (a) above, there exists a sequence $t_n \rightarrow \infty$ ($n \rightarrow \infty$) such that $T_H(t_n) \rightarrow T_H^\infty$, $T_H' \rightarrow 0$, $n \rightarrow \infty$. Therefore from T_H' -equation in 2.9,

$$0 \leftarrow T_H'(t_n) = \gamma I_H(t_n) - (\theta + \mu_h) T_H(t_n)$$

Hence, $T_H^\infty \leq \frac{\gamma}{\theta + \mu_H} I_H^\infty$.

- (c) Similarly as in (b), we obtain following relations

$$\begin{aligned}
T_H^\infty &\leq \frac{\gamma}{\theta + \mu_H} I_H^\infty, & R_H^\infty &\leq \frac{\theta\phi}{\mu_h} T_H^\infty, \\
I_H^\infty &\leq \frac{\theta(1-\phi)}{2\mu_H + \theta + \gamma} Z_H^\infty, & I_H^\infty &\leq \frac{\theta(1-\phi)}{\gamma + \mu_H} T_H^\infty, \\
T_{H\infty} &\geq \frac{\gamma}{\theta + \mu_H} I_H^\infty, & R_H^\infty &\leq \frac{\theta\phi}{\mu_h} T_H^\infty, & I_H^\infty &\leq \frac{\theta(1-\phi)}{2\mu_H + \theta + \gamma} Z_H^\infty.
\end{aligned}$$

- (d) In particular, (c) above implies that if $I_H(t)$ or $Z_H(t)$ converge for $t \rightarrow \infty$, so will $S_H(t)$, $T_H(t)$ and $R_H(t)$.

Proof. Suppose to the contrary that $Z_H(t) \rightarrow 0$, $t \rightarrow \infty$. Therefore we can find a sequence $t_n \rightarrow \infty$ with $Z_H(t_n) \rightarrow 0$, $n \rightarrow \infty$ and $Z'_H(t_n) < 0$. If $Z_H(t)$ tends to zero, then from Preliminary (d), so will $S_H(t)$, $T_H(t)$ and $R_H(t)$. It follows from S'_H - equation that $S_H(t) \rightarrow N_H$, $t \rightarrow \infty$. As $\tilde{R}_c^2 > 1$, $S_H(t_n) - N_H/\tilde{R}_c^2 > 0$ for sufficiently large n i.e. $Z'_H(t_n) \geq 0$. This is a contradiction.

For the second part of the theorem, assume that $S_{H\infty} > N_H/\tilde{R}_c^2$. Then, $Z'_H(t) \geq 0$ for sufficiently large t and $Z_H(t)$ converges for $t \rightarrow \infty$ and so do $S_H(t)$, $T_H(t)$ and $R_H(t)$ from Preliminary (d). As the system does not converge towards the DFE, it converges to the EE (endemic equilibrium). In particular $S_{H\infty} \leq N_H/\tilde{R}_c^2$ which is a contradiction. \square

Corollary 3. Let $\tilde{R}_c^2 > 1$. If $Z_H(0)/geq 0$,

$$Z_H^\infty \geq I_H^\infty \geq \left(1 + \frac{\gamma}{\mu_H} \frac{\theta\phi + \mu_H}{\theta + \mu_H}\right)^{-1} \left(1 - \frac{1}{\tilde{R}_c^2}\right) N_H =: \epsilon_0$$

Proof. Combine the estimates in Preliminary (d) above,

$$I_H^\infty + T_H^\infty + R_H^\infty \leq I_H^\infty \left(1 + \frac{\gamma}{\mu_H} \frac{\theta\phi + \mu_H}{\theta + \mu_H}\right) \quad (\text{B.4})$$

Note that from Theorem 4

$$I_H^\infty + T_H^\infty + R_H^\infty \geq (N_H - S_H)^\infty = N_H - S_{H\infty} \geq \left(1 - \frac{1}{\tilde{R}_c^2}\right) N_H \quad (\text{B.5})$$

Combining equations B.4 and B.5, we get the desired condition. \square

REFERENCES

- [1] Brauer F., Castillo-Chavez C., *Mathematical models in population biology and epidemiology*, vol. 40. Springer, 2012.
- [2] Thieme H. R., *Mathematics in population biology*. Princeton University Press, 2018.
- [3] P. Van den Driessche and J. Watmough, “Reproduction numbers and sub-threshold endemic equilibria for compartmental models of disease transmission,” *Mathematical biosciences*, vol. 180, no. 1-2, pp. 29–48, 2002.
- [4] Diekmann O., Heesterbeek J. A. P., Roberts M. G., “The construction of next-generation matrices for compartmental epidemic models,” *Journal of the Royal Society Interface*, vol. 7, no. 47, pp. 873–885, 2009.
- [5] C. Castillo-Chavez and B. Song, “Dynamical models of tuberculosis and their applications,” *Mathematical biosciences and engineering*, vol. 1, no. 2, pp. 361–404, 2004.

- [6] Pandey A., Mubayi A., Medlock J., “Comparing vector–host and SIR models for dengue transmission,” *Mathematical Biosciences*, vol. 246, no. 2, pp. 252 – 259, 2013.
- [7] de León C. V., Hernández J. A. C., “Local and Global Stability of Host-Vector Disease Models,” *Foro-Red-Mat: Revista electrónica de contenido matemático*, vol. 25, no. 3, pp. 1–8, 2008.

APPENDIX C

PROPOSED EXTENSIONS FOR MODEL IN CHAPTER 2

Clinical symptoms based behavior change: Model

Studies have reported that the patients tend to stop taking medication or treatment once the symptoms of the disease subside (1; 2; 3). Therefore, we propose an age-of-infection equivalent model as *age-of-treatment* capturing the increased rate of non-adherence based on the progressing time spent in the treatment compartment by infected people. The complete model is:

$$\begin{aligned}
 \frac{dS_H}{dt} &= \Lambda_H - b\beta_{VH}S_H \frac{I_V}{N_H} - \mu_H S_H \\
 \frac{dI_H}{dt} &= b\beta_{VH}S_H \frac{I_V}{N_H} - \gamma I_H + \int_0^n \theta(1 - \phi(\tau))T_H(t, \tau)d\tau - (\delta + \mu_H)I_H \\
 \frac{\partial T_H}{\partial t} + \frac{\partial T_H}{\partial \tau} &= \gamma I_H - \theta(1 - \phi(\tau))T_H(t, \tau) + \theta\phi(\tau = n)T_H(t, \tau) - \mu_H T_H(t, \tau) \\
 \frac{dR_H}{dt} &= \theta \int_0^n \phi(\tau = n)T_H(t, \tau)d\tau - \mu_H R_H \\
 \frac{dS_V}{dt} &= \Lambda_V - b\beta_{HV}S_V \frac{I_H + \int_0^n \alpha T_H(t, \tau)d\tau}{N_H} - \mu_V S_V \\
 \frac{dI_V}{dt} &= b\beta_{HV}S_V \frac{I_H + \int_0^n \alpha T_H(t, \tau)d\tau}{N_H} - \mu_V I_V
 \end{aligned} \tag{C.1}$$

where τ is the time since initiation of treatment and thus $T(t, 0)$ denotes the number of people who have newly initiated the treatment and n is the duration of treatment. For VL treatment, $n = 28$ days for Miltefosine regime, which is the first-line treatment.

$$R_c^2 = \frac{b\beta_{HV}}{(\delta + \mu_H + \gamma)} \frac{b\beta_{VH}}{\mu_V} \frac{N_V}{N_H}$$

Prospective models to capture different causes and outcomes of treatment non-adherence

To extend the VL dynamics model (Equation 2.1) to capture the treatment non-adherence behavior driven by specific causes, we present the following scenarios and corresponding mechanistic changes.

Awareness based behavior change

During outbreaks, as people see the rising number of fatalities and cases of a disease, they are more aware of the disease and its horrors and therefore tend to change their behavior to take more preventive measures (4). Funk et. al. (2010) also review various studies which have focused on behavior changes due to prevalence which result in the change of model parameters (4). Studies have shown that improved disease awareness leads to a higher treatment adherence (5; 6). Thus, we propose the parameter ϕ , proportion of infected people adhering to the treatment, of the model 2.1 to be a function of the prevalence. That is instead of the constant, the parameter is now $\phi(I_H)$, a saturating function (Holling Type II), such that $\phi \rightarrow 1$ as I_H increases (see Figure C.1).

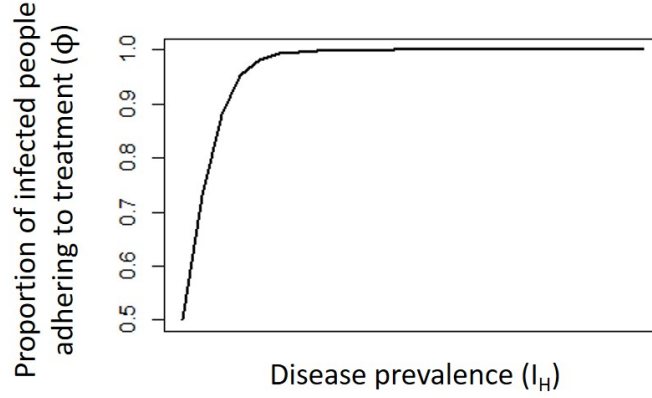

Figure C.1: Schematic plot of the parameter if proportion of infected people adhering to the treatment (ϕ) as a saturating function of disease prevalence (I_H).

Clinical symptoms based behavior change

Studies have reported that the patients tend to stop taking medication or treatment once the symptoms of the disease subside (1; 2; 3). Therefore, we propose and age-of-infection equivalent model as *age-of-treatment* capturing the increased rate of non-adherence based on the progressing time spent in the treatment compartment by infected people. The complete model is included in the Appendix ??.

$$\begin{aligned}
 \frac{dI_H}{dt} &= b\beta_{VH}S_H\frac{I_V}{N_H} - \gamma I_H + \int_0^n \theta(1 - \phi(\tau))T_H(t, \tau)d\tau - (\delta + \mu_H)I_H \\
 \frac{\partial T_H}{\partial t} + \frac{\partial T_H}{\partial \tau} &= \gamma I_H - \theta(1 - \phi(\tau))T_H(t, \tau) + \theta\phi(\tau = n)T_H(t, \tau) - \mu_H T_H(t, \tau) \quad (C.2) \\
 \frac{dR_H}{dt} &= \theta \int_0^n \phi(\tau = n)T_H(t, \tau)d\tau - \mu_H R_H
 \end{aligned}$$

where τ is the time since initiation of treatment and thus $T(t, 0)$ denotes the number of people who have newly initiated the treatment and n is the duration of treatment. For VL treatment, $n = 28$ days for Miltefosine regime, which is the first-line treatment.

Side-effect structured non-adherence

After reviewing Visceral Leishmaniasis treatment regimes in Bihar, India, it was seen that the majorly used drugs are Miltefosine, AmBiosome and paramomycin. Each of these treatments have side-effects ranging from mild, like abdominal pain, vomiting, back pain and cough, to severe, like dermatitis, hypersensitivity reaction, atrial ectopic, severe abdominal pain and severe vomiting (7). One of the main causes of non-adherence to VL treatment has been shown to be the side-effects (8). Based on the severity of the side-effects, we propose a model which captures different treatment adherence behavior. As shown in Figure C.2, the people suffering from adverse side-effects (A_i 's; $i = 1, 2, \dots, n$) default from the treatment follow a gamma-distributed wait time. That is, most of them default after around $1/\eta$ time units as shown in

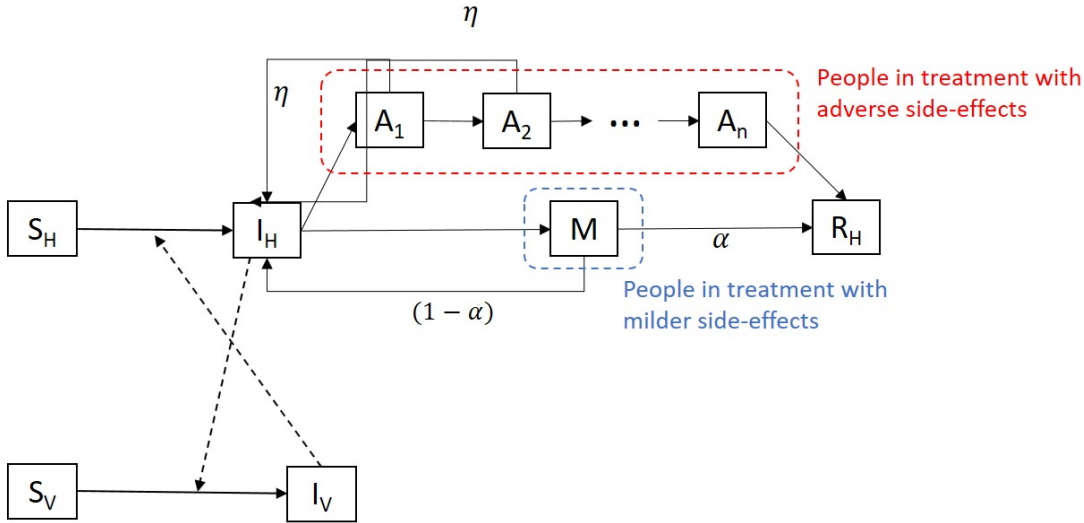

Figure C.2: Flowchart of the Side-Effect Structured Non-Adherence in VL Transmission Dynamics Model

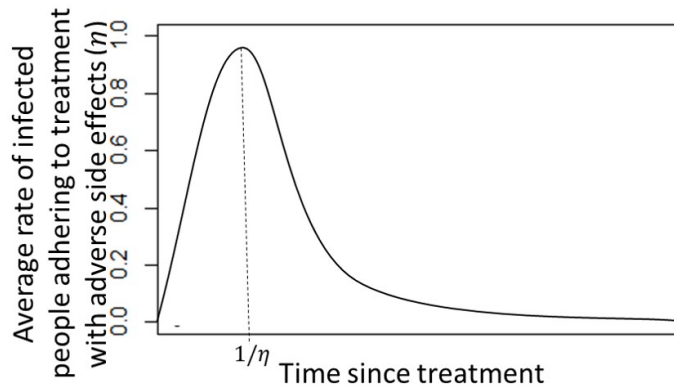

Figure C.3: Schematic Representation of Distribution of Non-Adherence to Treatment for People with Adverse Side-Effects

Figure C.3. And the people suffering from milder side-effects follow an exponentially decaying wait time. That is, as they progress through the treatment, the adherence level decreases (Figure C.4). This is motivated from the survey study in (9) which remarks that the people in the endemic regions of South-east Asian countries are not aware of the treatment side-effects. Therefore, in the beginning of the treatment due unexpected adverse side-effects, and thus default from the treatment at a higher rate than in the later days of treatment.

Infected sandflies-density based behavior change

We assume that awareness of the disease also depends on the density of infected sandflies in the regions. A heavily infected sandfly bites more frequently than an

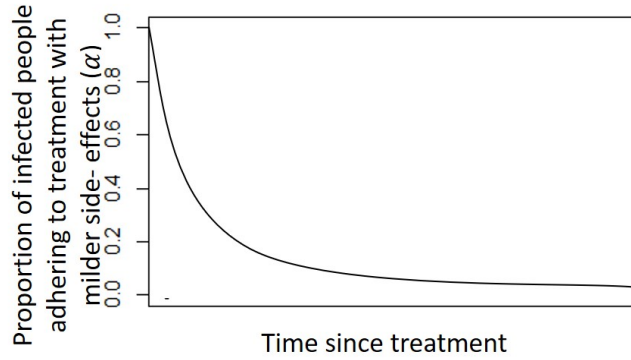

Figure C.4: Schematic Representation of Distribution of Non-Adherence to Treatment for People with Milder Side-Effects

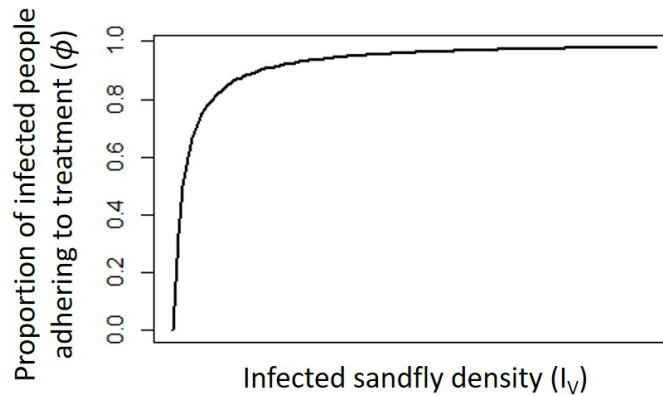

Figure C.5: Schematic plot of the parameter if proportion of infected people adhering to the treatment (ϕ) as a Holling's type II function of infected sandfly density (I_V).

uninfected sandfly (10). Therefore, as the density of infected sandflies increases, people, aware of the threat of VL due to being bitten more, may adhere more to the treatment. In this case the corresponding parameter ϕ will be a function of I_V . We propose a Holling's type II function such that

$$\phi(I_V) = \frac{nI_V}{m + nI_V}$$

Figure C.5 shows the graph of the behavior change.

Access-based behavior change

With 76% of the population living under recurring threat of flood devastation, Bihar is the most flood-prone state of India (11). Due to such heavy rainfall in the catchment areas of the river, the healthcare facilities are inaccessible to the population during the monsoon months (July to October). Thus, the proportion of population's

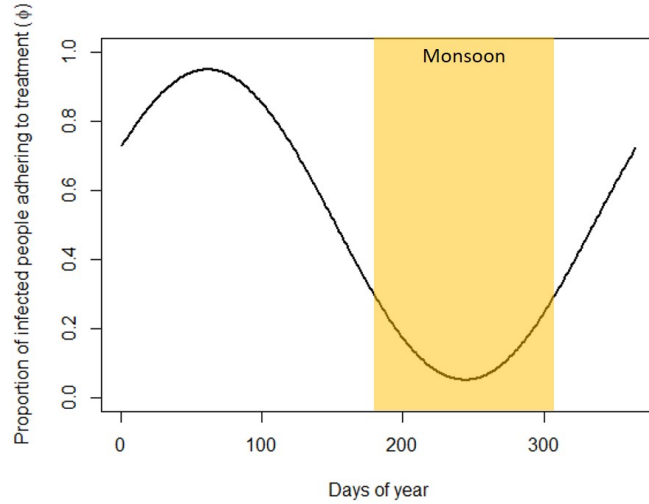

Figure C.6: Schematic Plot of Seasonal Treatment Adherence due to Reduced Access to Health-Care Facility During the Monsoon.

adherence to the treatment (ϕ) is proposed to exhibit a seasonal behavior as a function of time of the year

$$\phi(t) = \phi_0 \left(1 + \phi_1 \sin \frac{2\pi(t + t_0)}{365} \right)$$

such that monsoon sees the lowest adherence as shown in Figure C.6.

But, we should expect only a third of the year to face access difficulties instead of the periodic behavior spanning over the year uniformly. Thus, we expect more like Figure C.7 achieved from the functional form of ϕ represented as

$$\phi(t) = \phi_0 \left(1 + \phi_1 \sin \frac{2\pi(t + t_1)}{365} + \phi_2 \cos \frac{2\pi(t + t_2)}{365} \right)$$

Alternatively, a periodic Heaviside step function can be constructed for more drastic changes in behavior during monsoon.

REFERENCES

- [1] J. G. Ayisi, A. H. van't Hoog, J. A. Agaya, W. Mchembere, P. O. Nyamthimba, O. Muhenje, and B. J. Marston, "Care seeking and attitudes towards treatment compliance by newly enrolled tuberculosis patients in the district treatment programme in rural western kenya: a qualitative study," *BMC public health*, vol. 11, no. 1, p. 515, 2011.
- [2] F. für Internationale Tuberkulosehilfe, "Treatment default." Accessed March, 2019.

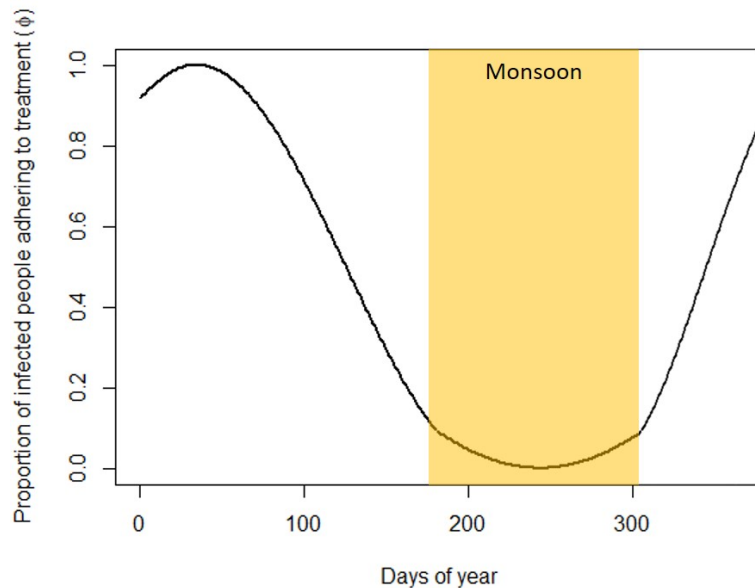

Figure C.7: Schematic Plot of Seasonal Treatment Adherence due to Reduced Access to Health-Care Facility Updated for Different Period of Seasonality During the Monsoon.

- [3] I. Cherkaoui, R. Sabouni, D. Kizub, A. C. Billieux, K. Bennani, J. E. Bourkadi, A. Benmamoun, O. Lahlou, R. El Aouad, and K. E. Dooley, “Treatment default amongst patients with tuberculosis in urban morocco: predicting and explaining default and post-default sputum smear and drug susceptibility results,” *PloS one*, vol. 9, no. 4, p. e93574, 2014.
- [4] S. Funk, M. Salathé, and V. A. A. Jansen, “Modelling the influence of human behaviour on the spread of infectious diseases: a review,” *Journal of The Royal Society Interface*, vol. 7, no. 50, pp. 1247–1256, 2010.
- [5] A. Rondags, A. B. Himawan, J. F. Metsemakers, and T. N. Kristina, “Factors influencing non-adherence to tuberculosis treatment in jepara, central java, indonesia,” *Southeast Asian Journal of Tropical Medicine and Public Health*, vol. 45, no. 4, p. 859, 2014.
- [6] L. C. Plantinga, L. E. Boulware, J. Coresh, L. A. Stevens, I. Miller, Edgar R., R. Saran, K. L. Messer, A. S. Levey, and N. R. Powe, “Patient Awareness of Chronic Kidney Disease: Trends and Predictors,” *Archives of Internal Medicine*, vol. 168, pp. 2268–2275, 11 2008.
- [7] V. Goyal, R. Mahajan, K. Pandey, S. N. Singh, R. S. Singh, N. Strub-Wourgaft, F. Alves, V. N. R. Das, R. K. Topno, B. Sharma, *et al.*, “Field safety and effectiveness of new visceral leishmaniasis treatment regimens within public health facili-

ties in bihar, india,” *PLoS neglected tropical diseases*, vol. 12, no. 10, p. e0006830, 2018.

- [8] Kansal, S., Chakravarty, J., Kumar, A., Malaviya, P., Boelaert, M., Hasker, E., Ostyn, B., Sundar, S., “Risk Factors associated with defaulting from visceral leishmaniasis treatment: analysis under routine programme conditions in Bihar, India,” *Tropical Medicine & International Health*, vol. 22, no. 8, pp. 1037–1042, 2017.
- [9] Uranw S., Ostyn B., Dorlo T. P.C., Hasker E., Dujardin B., Dujardin J. C., Rijal S., Boelaert M., “Adherence to miltefosine treatment for visceral leishmaniasis under routine conditions in Nepal,” *Trop Med Int Health*, vol. 18, pp. 179—187, 2013.
- [10] A. Croft, N. Taylor, and K. Rodenhurst, “Sandflies and leishmaniasis,” *The Lancet*, vol. 367, no. 9505, p. 112, 2006.
- [11] B. Water resources department, “Flood management information system: Flood history,” Accessed March, 2019.

APPENDIX D

MATHEMATICAL ANALYSIS OF MODELS IN CHAPTER 3

Probability distribution of the probability of leaving treatment class

Based on the data in the Figure 2.5, the goal is to find the underlying distribution of the probability of leaving treatment. We compare the goodness of fit of best fit exponential distribution and best fit gamma distribution.

The scale parameter in the exponential distribution ($\mu = 1/\lambda$) is calculated as the weighted average of the proportion of people leaving in corresponding days since treatment initiation.

$$\implies \frac{1}{\lambda} = \frac{\sum_{i=1}^5 p_i t_i}{\sum_{i=1}^5 t_i} = 0.15$$

where t_i is the i^{th} time point since treatment initiation and p_i is the corresponding proportion of people leaving treatment at the i^{th} time point. That is the rate is 0.15×7 per week (i.e. per time interval in data).

To find α (shape parameter) and β (rate parameter) for best fit gamma distribution, we use the facts that mean of the distribution is α/β and variance is α/β^2 . Therefore $\beta = \frac{Mean}{Variance}$. The weighted mean (μ ; similar as above) is equal to 0.15. Weighted variance is calculated as

$$\sigma^2 = \frac{\sum_{i=1}^5 t_i (p_i - \mu)^2}{\sum_{i=1}^5 t_i} = 0.0192$$

Therefore, $\beta = 1.118$ and $\alpha = 1.174$.

System of equations : Model I

Model I is described by following equations:

$$\frac{dS_H}{dt} = \Lambda_H - b\beta_{VH}S_H \frac{I_V}{N_H} - \mu_H S_H \quad (D.1)$$

$$\frac{dI_H}{dt} = b\beta_{VH}S_H \frac{I_V}{N_H} - \gamma I_H - \mu_H I_H + n\theta_1 \sum_{i=1}^n T_i \quad (D.2)$$

$$\frac{dT_1}{dt} = \gamma I_H - n(\theta_1 + \rho)T_1 - \mu_H T_1 \quad (D.3)$$

$$\frac{dT_i}{dt} = n\rho T_{(i-1)} - n(\gamma + \alpha)T_i - \mu_H T_i \quad 2 \leq i \leq n \quad (D.4)$$

$$\frac{dR_H}{dt} = \theta_2 T_n - \mu_H R_H \quad (D.5)$$

$$\frac{dS_V}{dt} = \mu_V N_V - b\beta_{HV}S_V \frac{I_H + \alpha n \sum_{i=1}^n T_i}{N_H} - \mu_V S_V \quad (D.6)$$

$$\frac{dI_V}{dt} = b\beta_{HV}S_V \frac{I_H + \alpha n \sum_{i=1}^n T_i}{N_H} - \mu_V I_V \quad (D.7)$$

where $N_H = S_H + I_H + \sum_{i=1}^n T_i + T_H + R_H$ and $N_V = S_V + I_V$ are constant.

System of Equations: Model II

The model (Figure 3.5) is described by the following set of differential equations:

$$\frac{dS_H}{dt} = \Lambda_H N_H - b\epsilon\beta_{VH} S_H \frac{I_V}{N_H} - \mu_H S_H \quad (\text{D.8})$$

$$\frac{dI_H}{dt} = b\epsilon\beta_{VH} S_H \frac{I_V}{N_H} - \gamma_H I_H - \mu_H I_H \quad (\text{D.9})$$

$$\frac{dT_H}{dt} = (1 - \phi)\gamma_H I_H - \theta_1 T_H + \xi\eta V_H - \mu_H T_H \quad (\text{D.10})$$

$$\frac{dV_H}{dt} = \theta_1 T_H - \eta V_H - \mu_H V_H \quad (\text{D.11})$$

$$\frac{dC_H}{dt} = \phi\gamma_H I_H + (1 - \xi)\eta V_H - \theta_2 C_H - \mu_H C_H \quad (\text{D.12})$$

$$\frac{dW_H}{dt} = \theta_1 C_H - \mu_H W_H \quad (\text{D.13})$$

$$\frac{dS_V}{dt} = \Lambda_V(1 - \psi)N_V - (b\epsilon\beta_{HV}I_H + \alpha b\epsilon\beta_{HV}V_H)\frac{S_V}{N_H} - \mu_V S_V - \delta_V S_V \quad (\text{D.14})$$

$$\frac{dI_V}{dt} = (b\epsilon\beta_{HV}I_H + \alpha b\epsilon\beta_{HV}V_H)\frac{S_V}{N_H} - \mu_V I_V - \delta_V I_V \quad (\text{D.15})$$

Mathematical Analysis: Model II

Endemic equilibrium

The endemic equilibrium of the complete model is given by:

$$I_H^* = \frac{R_c^2 \Lambda_H \Lambda_V N_H (1 - \psi) - \mu_H N_H (\mu_V + \delta_V)}{\Lambda_V (1 - \psi) (\gamma_H + \mu_H) R_c^2 + b\epsilon\beta_{HV} \mu_H R_2} \quad (\text{D.16})$$

$$T_H^* = \frac{(1 - \phi)\gamma_H (\eta + \mu_H)}{(\eta + \mu_H)(\theta_1 + \mu_H) - \eta\xi\theta_1} I_H^* \quad (\text{D.17})$$

$$C_H^* = \frac{\phi\gamma_H (\eta + \mu_H)(\theta_1 + \mu_H) - \eta\theta_1\gamma_H(1 - \phi - \xi)}{(\theta_2 + \mu_H)[(\eta + \mu_H)(\theta_1 + \mu_H) - \eta\xi\theta_1]} I_H^* \quad (\text{D.18})$$

$$V_H^* = \frac{\theta_1}{\eta + \mu_H} T_H^* \quad (\text{D.19})$$

$$W_H^* = \frac{\theta_2}{\mu_H} C_H^* \quad (\text{D.20})$$

$$S_V^* = \frac{\Lambda_V N_H N_V (1 - \psi)}{b\epsilon\beta_{HV} R_2 I_H^* + (\mu_V + \delta_V) N_H} \quad (\text{D.21})$$

$$I_V^* = \frac{\mu_H N_H (\gamma_H + \mu_H) I_H^*}{b\epsilon\beta_{VH} (\Lambda_H N_H - (\gamma_H + \mu_H) I_H)} \quad (\text{D.22})$$

where

$$R_2 = 1 + \frac{\alpha\theta_1\gamma_H(1 - \phi)}{(\eta + \mu_H)(\theta_1 + \mu_H) - \eta\theta_1\xi}$$

REFERENCES

APPENDIX E
ICER RESULTS FOR CHAPTER 4

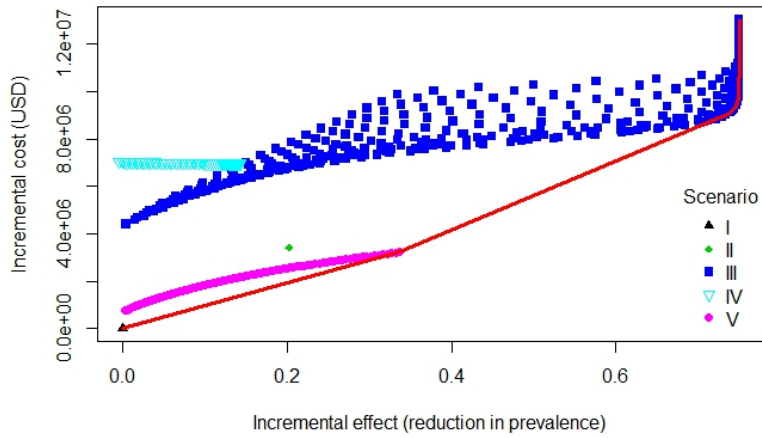

Figure E.1: Cost-Effectiveness Plane of All Scenarios with the Cost-effective Frontier Represented in Red Curve.

ICER results

Figure E.1 shows that some strategies in Scenario V (risk-based MDA) and Scenario III (age-structured MDA with high availability of pills) lie on the cost-effective frontier. Therefore, current policy or any other age-structured MDA policy with low availability of pills is not cost-effective compared to the ones on the cost-effective frontier.