

Inactivation of Bacteria and Viruses in Water Using Ultraviolet Light and Advanced  
Oxidation Processes in a Bench-scale and Two Pilot-scale Systems

by

Majid Nikougoftar Zarif

A Thesis Presented in Partial Fulfillment  
of the Requirements for the Degree  
Master of Science

Approved November 2017 by the  
Graduate Supervisory Committee:

Morteza Abbaszadegan, Chair  
Peter Fox  
Otakuye Conroy-Ben

ARIZONA STATE UNIVERSITY

December 2017

## ABSTRACT

Adenoviruses cause gastrointestinal illnesses and have been listed on the U.S. EPA's Contaminant Candidate Lists (CCL). They are highly resistant to ultraviolet (UV) inactivation. Advanced oxidation processes (AOPs) are known to improve inactivation of microorganisms and simultaneously oxidize organics. The bacteriophage P22 was selected as a surrogate for adenoviruses due to their physical and genetic similarities.

The main objective of this study was to compare the synergic disinfection potential of titanium dioxide (TiO<sub>2</sub>) or peracetic acid (PAA) with UV for viruses and bacteria in water.

Both bench-scale and pilot-scale evaluation was done. A bench-scale collimated beam was included to evaluate the inactivation of P22 and *E. coli* by UV with and without TiO<sub>2</sub> or PAA. A Purifics Photo-Cat system which is an integrated UV/ceramic membrane reactor was used for the pilot-scale TiO<sub>2</sub>-UV AOP experiments. For pilot-scale PAA-UV AOP experiments, an in-line D222 UV reactor unit provided by NeoTech Aqua Solutions, Inc. was used.

TiO<sub>2</sub> doses of 1, 10, and 40 mg/L were applied in the collimated beam and the Photo-Cat system. Higher TiO<sub>2</sub> doses resulted in a higher inactivation in the Photo-Cat and lower inactivation in the collimated beam apparatus. Adding 40 mg/L of TiO<sub>2</sub> in the photo-Cat system improved P22 inactivation by 25% while it slightly decreased P22 inactivation in collimated beam apparatus.

PAA doses of 0.25 or 0.5 ppm were continuously injected upstream of the UV light and a 53% or 90% increase in inactivation was observed for *E. coli*, respectively, as compared to UV alone. However, P22 required higher dose with PAA-UV AOP and

PAA concentrations of 1 or 10 ppm resulted in an 18% and 70% increase in the inactivation respectively, as compared to UV alone. Interestingly, when the same condition was applied to water with more organics (UVT 79%), *E. coli* exhibited the same level of susceptibility to PAA-UV AOP while P22 inactivation decreased.

The results provide new insight on the effectiveness and applicability of adding AOP to UV for microbial inactivation in water. PAA-UV AOP can potentially enhance existing UV disinfection systems with minimal chemical addition, and a simple retrofit to existing UV units.

## DEDICATION

I dedicate my thesis work to my family. A very special and sincere feeling of gratitude goes to my loving parents, Reza and Mahin who always supported me through this path and encouraged me to work harder and be positive about future.

## ACKNOWLEDGMENTS

I like to thank my committee members for helping me on each and every steps of this thesis. Dr. Morteza Abbaszadegan was more than generous with his expertise and time and this thesis would not have been possible without his support.

I want to specially thank Dr. Absar Alum for having the patience to train me, giving me advice, helping me with the experiments and giving me hopes when I needed that.

I should express my deepest love to my brothers, Vahid and Navid and my sister-in-laws, Leila and Sahar for always giving me energy and motivation toward my research.

I would also like to thank NeoTech Aqua Solutions, Inc, for providing D222 UV reactor unit and Solvay for providing peracetic acid solution. This study was funded by NSF Water and Environmental Technology center (WET) at Arizona State University and therefore I acknowledge their support to complete this research.

## TABLE OF CONTENTS

	Page
LIST OF TABLES .....	viii
LIST OF FIGURES .....	ix
CHAPTER	
1 INTRODUCTION .....	1
1.1 Need for Alternative Disinfectants .....	2
1.2 Ultraviolet Light as a Candidate; Advantages and Disadvantages .....	3
1.3 Need for The Present Study .....	6
1.4 Study Objectives .....	6
2 BACKGROUND LITERATURE .....	8
2.1 Advanced Oxidation Processes (AOPs).....	8
2.1.1 Titanium Dioxide (TiO <sub>2</sub> )-UV .....	10
2.1.1.1 TiO <sub>2</sub> -UV Mechanism .....	10
2.1.1.2 TiO <sub>2</sub> -UV Effect on Organic Degredation .....	11
2.1.1.3 TiO <sub>2</sub> -UV Effect on Inactivation of Microorganisms .....	13
2.1.2 Peracetic Acid (PAA)-UV .....	15
2.1.2.1 PAA-UV Mechanism.....	16
2.1.2.2 PAA-UV Effect on Organic Degredation .....	17
2.1.2.3 PAA-UV Effect on Inactivation of Microorganisms .....	17
3 METHODOLOGY .....	20
3.1 UV Devices Used in this Study .....	20
3.1.1 Collimated Beam Apparatus .....	20

CHAPTER	Page
3.1.1.1 Procedure for Conducting Experiments using Collimated Beam Apparatus .....	23
3.1.2 Purifics Photo-Cat.....	25
3.1.2.1 Purifics Photo-Cat; Experimental Procedure .....	27
3.1.3 D222 UV Unit from NeoTech Aqua Solutions.....	28
3.1.3.1 Experimental procedure using D222 UV unit .....	31
3.2 Microorganisms; Preparation and Assay .....	32
3.2.1 <i>E. coli</i> .....	32
3.2.2 P22 .....	33
3.3 Titanium Dioxide (TiO <sub>2</sub> ).....	34
3.4 Peracetic Acid (PAA) .....	35
3.5 Water Quality Paramter Measurements .....	35
3.5.1 Dissolved Organic Carbon (DOC).....	35
3.5.2 pH .....	35
3.5.3 Turbidity .....	36
3.5.4 UV Transmittance (UVT) .....	36
3.5.5 Mean Effective Diameter of TiO <sub>2</sub> particles.....	36
4 RESULTS AND DISCUSSION .....	37
4.1 Bench-scale Inactivation Experiments .....	37
4.1.1 Inactivation of <i>E. coli</i> , Using Collimated Beam Apparatus by UV or TiO <sub>2</sub> -UV .....	37

CHAPTER	Page
4.1.2 Inactivation of P22, Using Collimated Beam Apparatus by UV or TiO <sub>2</sub> -UV .....	39
4.1.3 Inactivation of <i>E. coli</i> , Using Collimated Beam Apparatus by UV or PAA-UV .....	43
4.1.4 Inactivation of P22, Using Collimated Beam Apparatus by UV or PAA-UV .....	44
4.2 Pilot-scale Inactivation Experiments .....	46
4.2.1 Inactivation of P22, Using Purifics Photo-Cat by UV or TiO <sub>2</sub> -UV .....	46
4.2.2 Inactivation of <i>E. coli</i> and P22, Using D222 UV Device by UV or PAA-UV .....	49
5 CONCLUSION .....	54
REFERENCES .....	55
APPENDIX	
A RAW DATA .....	65



## LIST OF TABLES

Table	Page
1. List of Different Advanced Oxidation Processes Reactants .....	9
2. Water Quality Parameters for Bench-scale TiO <sub>2</sub> -UV AOP Experiments .....	41
3. Water Quality Parameters for Bench-scale PAA-UV AOP Experiments .....	46
4. Water Quality Parameters for Pilot-scale TiO <sub>2</sub> -UV AOP Experiments .....	48
5. Influent Quality Parameters for Pilot-scale PAA-UV AOP Experiments .....	51
6. Effluent Quality Parameters for Pilot-scale PAA-UV AOP Experiments .....	52

## LIST OF FIGURES

Figure	Page
1. Schematic of the Collimated Beam Apparatus.....	21
2. Picture of the Collimated Beam Apparatus Used in This Study.....	22
3. AvaSpec Radiometer from Avantes .....	23
4. Schematic of Photo-Cat from Purifics .....	26
5. Picture of Photo-Cat system from Purifics used in this study.....	26
6. Schematic of D222 UV unit from NeoTech Aqua Solutions .....	28
7. Picture of D222 UV unit, from NeoTech Aqua Solutions website .....	29
8. Picture of D222 UV unit used in this study.....	29
9. Close-Up view of D222 UV device .....	29
10. Schematic of pilot-scale PAA-UV AOP experiments setup.....	30
11. Picture of pilot-scale PAA-UV AOP experiments setup .....	30
12. <i>E. coli</i> colonies grown on Brilliance media.....	33
13. P22 plaques formed on <i>Salmonella</i> lawn .....	34
14. Bench-scale Inactivation of <i>E. coli</i> by UV or TiO <sub>2</sub> -UV .....	38
15. Bench-scale Inactivation of P22 by UV or TiO <sub>2</sub> -UV.....	40
16. Bench-scale Inactivation of <i>E. coli</i> by UV or PAA-UV .....	43
17. Bench-scale Inactivation of P22 by UV or PAA-UV .....	45
18. Pilot-scale Inactivation of P22 by UV or TiO <sub>2</sub> -UV .....	47
19. Pilot-scale Inactivation of <i>E. coli</i> and P22 by UV or PAA-UV.....	50

## CHAPTER 1

### INTRODUCTION

Contaminated drinking water has been historically responsible for transmission of diarrheal diseases and enormous number of deaths worldwide. According to a report, 884 million people lacked access to basic and safe drinking water in 2015. In addition, more than 1,400 children under the age of 5 die every day due to diarrheal diseases linked to polluted water or poor sanitation while nearly 1,000 of the cases are preventable (World Health Organization (WHO) and the United Nations Children's Fund (UNICEF) 2017).

Disinfection is the most important and effective step in controlling such incidents by killing or inactivating disease-causing microorganisms in water. In 1908, Jersey City, NJ implemented the first continuous municipal use of chlorine to disinfect water in the US, resulting in a dramatic decline in rate of typhoid fever in local communities (McGuire 2006). Since then, chlorination as a means of water disinfection started to gain popularity in the United States. Cutler and Miller demonstrated that improved water quality and the introduction of filtration and chlorination led to considerable mortality rate decrease (Cutler, Miller 2005). Although other factors such as introduction of antibiotics and vaccination also contributed in decreased disease load, clean water has been linked to reduced incidence of typhoid fever, half of the reduction in overall mortality and more than two-third of the decline in child and infant mortality (Cutler, Miller 2005).

Although chlorination has brought many social health benefits, and is fairly inexpensive and easy to operate, some disadvantages like its high potential for formation of carcinogenic compounds and lack of efficiency in inactivating some of microbial

pathogens force scientists and utilities to study alternative disinfectants and innovative treatment technologies.

In 1900, the leading causes of deaths were reported to be Influenza, pneumonia, tuberculosis, diarrhea and enteritis whereas in the last decades heart disease and cancers account for the vast majority of deaths with cancer making up for 23% of all deaths in 2013 in the US (CDC-2017). Cancer has always been the second largest cause of deaths in the US since 2000 after heart diseases with marginal and shrinking difference (CDC-2017).

### 1.1 Need for Alternative Disinfectants

Disinfectants are strong oxidants that react with constituents in water. Chlorine is the most widely used disinfectant in the US mainly due to the low cost, high effectiveness, its known chemistry and ability to maintain residual in distribution pipelines. A wide variety of microorganisms are inactivated by free or combined chlorine (Howe et al. 2012). However, there are two major disadvantages associated with chlorination.

Firstly, chlorine and its species (chloramine, and chlorine dioxide) can react with natural organic matter (NOM) present in water and form disinfection by products (DBPs) that are proven to be carcinogenic (Richardson et al. 2007). The first disinfection by product was discovered in 1974 (Rook 1974). Since then, tremendous research has been done on their toxicology and adverse health effects (Boorman 1999, Richardson et al. 2007, Nieuwenhuijsen et al. 2000, Richardson 2003). To limit human exposure to these harmful byproducts, congress passed Safe Drinking Water Act (SDWA) in 1974 and it was amended twice in 1986 and 1996. These amendments eventually led to

announcement of stage 1 and stage 2 Disinfectants and Disinfection Byproducts Rule by United States Environmental Protection Agency (USEPA), which were aimed to lessen the risk of chlorinated byproducts. As of today, EPA has regulated 3 disinfectants and 11 chlorinated by products at federal level. However, there are many more unregulated disinfection by products some of which already listed in USEPA's candidate contaminant list 4 (CCL4) such as five different forms of nitrosamines.

The second reason other disinfectants are gaining interest over chlorination is because some microbes are resistant to chlorine and chlorine dioxide such as *Cryptosporidium parvum* oocyst and Giardia (Hoff, Rice & Schaefer 1984, Korich et al. 1990, USEPA 1999). Biofilms are resistant to chlorination as well. In addition, some microbes have developed increased resistance toward chlorination and they consequently require higher disinfectant doses to become inactivated, which can potentially result in a higher chance for formation of disinfection byproducts (LeChevallier, Cawthon & Lee 1988).

Once the limitations of the chlorination were identified, other disinfectants such as ozone and ultraviolet light started to gain interest and popularity.

## 1.2 Ultraviolet Light as a Candidate; Advantages and Disadvantages

Although the first application of ultraviolet light (UV) in drinking water was reported in 1910 in France, it was not until 1955 in Switzerland and Austria that UV light was used for municipal drinking water disinfection. When microorganisms are exposed to UV light, their nucleic acid (DNA or RNA) absorbs the light, mostly at a peak wavelength of around 254 nanometer, which induces damage and prevents the microbes from replicating. Since UV cannot maintain residual in water, most scholars believe that

UV followed by low concentrations of chlorine or its species is the best overall disinfection scenario. Although UV irradiation has not been associated with formation of DBPs by itself, when followed by chlorination, it doesn't necessarily decrease DBP concentrations (Reckhow et al. 2010, Liu et al. 2006). Liu and colleagues showed that under certain conditions, and compared to chlorination, sequential UV exposure and either chlorination or chloramination can slightly increase concentration of some specific DBPs, such as chloroform, dichloroacetic acid, trichloroacetic acid, and cyanogen chloride to the levels that are still below regulated DBP maximum contaminant level and therefore insignificant (Liu et al. 2006).

Although UV does not provide residual in the water, it sufficiently inactivates a wide variety of microorganisms including chlorine-resistant microbes at typical and practical doses (Craik et al. 2001, Clancy et al. 2000, Shin et al. 2001, Chang et al. 1985, Hijnen, Beerendonk & Medema 2006).

However, enteric adenoviruses are remarkably resistant to UV light disinfection and cause diseases such as diarrhea and gastroenteritis, especially to immunocompromised patients and children under the age of 5. Adenovirus occurrence has been mainly reported in sewage, and also recreation waters, rivers, surface waters, and groundwater all over the world (Jiang 2006) and even in drinking water sources and treated waters in South Korea, South Africa, West Africa and Brazil (Jiang 2006, Verheyen et al. 2009, Kluge et al. 2014). After noroviruses, adenoviruses are the most prevalent cause of water-borne disease outbreaks in recreational water (Sinclair, Jones & Gerba 2009).

Disinfection capability of chemical oxidants, namely chlorine, chlorine dioxide, and ozone has been evaluated on adenovirus inactivation as well as UV light. Adenovirus 40 appears to be the most resistant serotype of adenoviruses but still susceptible and sufficiently inactivated by chemical oxidants. (Jiang 2006, Nwachuku et al. 2005) Thurston-Enriquez et al., observed 99.99% inactivation of adenovirus 40 by a Ct value of less than 1.53 min-mg/L by chlorine dioxide while U.S. EPA requires 33.4 min-mg/L (Thurston-Enriquez et al. 2005b). Similarly, free chlorine and ozone achieved adenovirus 40 inactivation by doses lower than what is set by U.S. EPA and is common practice in treatment plants. Two logs of adenovirus 40 was inactivated by 1.5 mg-min/L of free chlorine in treated groundwater and 0.02 mg-min/L of ozone in oxidant demand free water (Thurston-Enriquez et al. 2005a, Thurston-Enriquez et al. 2003a). However, UV light does not seem to be as effective as other disinfectants on adenovirus 40 where a UV dose of 103 mJ/cm<sup>2</sup> is necessary to achieve 2 logs of inactivation in treated groundwater (Thurston-Enriquez et al. 2003b). This considerable resistance can possibly be explained by double-stranded DNA of adenoviruses and their ability to use the enzyme and machinery of the host cell to repair the induced damage (Day 1993).

Due to all the facts mentioned above from the occurrence of adenovirus to its outbreaks and UV resistance, U.S. EPA has always listed adenoviruses in the Contaminant Candidate List (CCL) since 1998 and has set a UV dose of 186 mJ/cm<sup>2</sup> to ensure 4 log inactivation of viruses. Nevertheless, Thurston-Enriquez demonstrated that a 226 and 203 mJ/cm<sup>2</sup> dose of UV light would be required for 4-log inactivation of adenoviruses from buffered-demand-free water and treated groundwater, using linear regression (Anonymous, Thurston-Enriquez et al. 2003b). It is also noteworthy to

mention that Linden and colleagues used pulsed UV source and medium-pressure polychromatic UV light for the first time to inactivate adenovirus 40 and they resulted in 4 logs inactivation by less than 40 and 60 mJ/cm<sup>2</sup>, respectively (Linden et al. 2007).

### 1.3 Need for the Present Study

Adenoviruses can survive very high doses of UV light. Advanced oxidation processes have shown to add synergy to UV light in terms of microbial inactivation. To date, no peer-reviewed article is available on efficacy of any advanced oxidation processes toward adenovirus inactivation, mainly due to the tediousness and difficulty of the procedure. Therefore, it is necessary to start to look at how adenoviruses can possibly respond to different advanced oxidation processes, especially because AOPs are becoming more prevalent among water utilities.

### 1.4 Study Objectives

In this work, bacteriophage P22 was used as a surrogate for human adenoviruses due to its physical and molecular similarities. In order to better understand impact of AOP on inactivation of adenoviruses and high resistance of adenoviruses against UV light, which is one of the limitations in use of low-pressure UV light for microbial disinfection, this study aims to investigate the efficacy of two advanced oxidation processes (AOPs) to inactivate bacteriophage P22. Inactivation of *E. coli*, as U.S. EPA's indicator of fecal contamination, by the processes used is also included to make the results more inclusive and conclusive. The specific objectives of this study listed below:

- Evaluating AOP inactivation of *E. coli* and bacteriophage P22 by TiO<sub>2</sub>-UV for water treatment applications.



- Evaluating AOP inactivation of *E. coli* and bacteriophage P22 by PAA-UV for both water and wastewater treatment applications.
- Comparison of UV inactivation of bacteriophage P22 from this work with UV inactivation of enteric adenoviruses derived from the literature.
- Comparison of the effectiveness of two different advanced oxidation processes used, TiO<sub>2</sub>-UV and PAA-UV, for inactivation of *E. coli* and P22.

## CHAPTER 2

### BACKGROUND LITERATURE

#### 2.1 Advanced Oxidation Processes (AOPs)

The term ‘advanced oxidation processes’ refers to a series of reactions that generate highly reactive oxygen species (ROS) ( $O_2^{\cdot-}$ ,  $H_2O_2$ , and mainly  $HO^{\cdot}$ ) with high reaction rate constants. Different reactants and reagents lead to different pathways but formation of  $HO^{\cdot}$  (With the exception of Sulfate-based AOPs) and transforming pollutants to harmless end products, such as  $CO_2$  and  $H_2O$ , is what all AOP reactions have in common (Deng, Zhao 2015, Zhang, Li-Xia & Jin-Ming 2008, Zhang et al. 2015). Hydroxyl radical with oxidation potential of 2.80 V, is among the strongest oxidants compared to common oxidants such as ozone, hydrogen peroxide, chlorine dioxide, and chlorine with oxidation potentials of 2.07, 1.78, 1.57, and 1.36 V respectively (Parsons 2004).  $HO^{\cdot}$  is a nonselective oxidant with reaction rate constant on the order of  $10^8$ - $10^{10} M^{-1}S^{-1}$  with a broad range of pollutants (Haag, Yao 1992). Consequently, it reacts with a wide variety of contaminants very fast (Andreozzi et al. 1999, Zhang et al. 2015). Although AOPs have been used for air and soil decontamination as well, water and wastewater industry have utilized AOPs the most as they can tackle pollution by inactivating harmful microorganism, destroying and mineralizing organics, removing heavy metals, reducing organic contents, color, and odor, and stabilization of biological sludge (Andreozzi et al. 1999, Comninellis et al. 2008, Deng, Zhao 2015). A comprehensive list of different AOP types is provided below:

Table 1. List of Different Advanced Oxidation Processes Reactants (Deng, Zhao 2015)

AOP type	Oxidant for Advanced Oxidation
O <sub>3</sub> /UV	HO·
TiO <sub>2</sub> /UV	HO·
PAA/UV	HO·
H <sub>2</sub> O <sub>2</sub> /UV	HO·
H <sub>2</sub> O <sub>2</sub> /O <sub>3</sub>	HO·
H <sub>2</sub> O <sub>2</sub> /O <sub>3</sub> /UV	HO·
Fe <sup>2+</sup> /UV	HO·
Fe <sup>2+</sup> / H <sub>2</sub> O <sub>2</sub>	HO·
Fe <sup>3+</sup> / H <sub>2</sub> O <sub>2</sub>	HO·
VUV (Vacuum UV)	HO·
Ultrasonic Irradiation	HO·
WAO (Wet Air Oxidation)	HO·
UV/Persulfate	SO <sub>4</sub> <sup>-</sup>
Heat/Persulfate	SO <sub>4</sub> <sup>-</sup>
Fe <sup>2+</sup> /Persulfate	SO <sub>4</sub> <sup>-</sup>
OH <sup>-</sup> /Persulfate	SO <sub>4</sub> <sup>-</sup>

Since TiO<sub>2</sub>-UV and PAA-UV are the AOPs selected for this study, a brief review of each is presented in the next section of this chapter.

### 2.1.1 Titanium Dioxide (TiO<sub>2</sub>)-UV

TiO<sub>2</sub> nanoparticles are semiconductor photo catalysts capable of producing reactive oxygen species when illuminated by UV light (Ishibashi et al. 2000, Cho et al. 2004, Gaya, Abdullah 2008). A brief summary on mechanism of formation of ROS, such as HO·, as well as organic mitigation and photocatalytic inactivation of microorganisms by TiO<sub>2</sub>-UV AOPs are presented in the following sections.

#### 2.1.1.1 TiO<sub>2</sub>-UV Mechanism

Previous studies have been done on mechanism of formation of HO· when surface of a semiconductor (e.g. TiO<sub>2</sub>) is exposed to a light source with energy equal to or greater than the band-gap energy ( $\Delta E_{bg}$ ) of the semiconductor (Fujishima, Rao & Tryk 2000, Hirakawa, Nosaka 2002, Fujishima, Zhang & Tryk 2008, Gaya, Abdullah 2008). The photons excites the electrons in the valence band and make them migrate to the empty conduction band, creating a positive hole ( $h^+_{vb}$ ) in the valence band while generating a free and active electron in the conduction band ( $e^-_{cb}$ ). The positive hole then can either directly oxidize the pollutants or generate HO· as a result of reacting with H<sub>2</sub>O, leading to further oxidation of organic contaminants. The transferred electron in the conduction band however, reduces oxygen molecules on the surface of the TiO<sub>2</sub> nanoparticle that can ultimately lead to formation of H<sub>2</sub>O<sub>2</sub> and OH·. Researchers have observed that oxidation of organic compounds occur both on the surface of TiO<sub>2</sub> nanoparticles and bulk solution (Cho et al. 2004, Thiruvengkatachari, Vigneswaran & Moon 2008, Chong et al. 2010). Hence, for photocatalytic advanced oxidations, adsorption of target contaminants to the nanoparticles might be desirable for achieving maximum degradation and/or disinfection.

Several studies have shown DNA and structural cell membrane damage stemmed from generated reactive oxygen species (Ashikaga et al. 2000, Kim et al. 2005, Kim et al. 2013).

In water and wastewater applications, the point of zero charge (PZC) of the particles and pH of the solution directly and mutually affect adsorption of particles by altering their surface charge.

#### 2.1.1.2 TiO<sub>2</sub>-UV Effect on Organic Degradation

Natural organic matter (NOM) is a term used for a heterogeneous mixture of organics coming from different sources with varying characteristics (Liu et al. 2008b). “NOM is ubiquitous in surface water and groundwater” and its concentration has increased over the past decades (Liu et al. 2008b, Matilainen, Vepsäläinen & Sillanpää 2010). Presence of NOM can be problematic for water utilities. From an aesthetic point of view, high concentrations of NOM can cause color, taste, and odor to the water (Liu et al. 2008b). They can also disrupt conventional water treatment processes such as coagulation, ion exchange and filtration and result in operational complication, increasing cost and chemical usage (Liu et al. 2008b, Matilainen, Sillanpää 2010). Additionally, since NOM is a precursor of DBPs in both drinking water and wastewater, it poses a serious challenge for utilities that utilize chlorine and its species as primary disinfection (Liu et al. 2008b). In order to eliminate the possibility of formation of DBPs, the best solution is to reduce NOM concentration of the water as much as possible prior to disinfection (Liu et al. 2008b). However, alternative disinfectants (disinfectants other than chlorine species) do not necessarily contribute to DBP formation by reacting with NOM, and in certain circumstances, they can even degrade the organic matters (Eggins,

Palmer & Byrne 1997, Liu et al. 2008b, Liu et al. 2008a, Huang, Leal & Li 2008, Gerrity et al. 2009, Matilainen, Sillanpää 2010, Matilainen, Vepsäläinen & Sillanpää 2010, Liu et al. 2010, Lamsal, Walsh & Gagnon 2011).

NOM is usually quantified by measuring dissolved organic carbon (DOC), UV absorbance at wavelength equal to 254 nm (Lamsal, Walsh & Gagnon 2011). To characterize the nature of NOM, parameters such as specific UV absorbance (SUVA), molecular weight distribution, and high-performance liquid chromatography (HPLC) results are studied (Lamsal, Walsh & Gagnon 2011).

A wealth of published literature, support degradation of NOM and DBP formation potential (e.g. trihalomethane formation potential (THMFP) and haloacetic acid formation potential (HAAFP)) by varying degrees, using TiO<sub>2</sub> photocatalysis. (Matilainen, Sillanpää 2010, Eggins, Palmer & Byrne 1997, Liu et al. 2008a, Liu et al. 2010, Gerrity et al. 2009) Brian R. Eggins and coworkers showed complete degradation of 10 mg of humic acid in 50 minutes using 1,000 mg/L TiO<sub>2</sub> illuminated by mercury lamp (Eggins, Palmer & Byrne 1997). A change in the characteristic of the solution was concluded due to the observed shift of higher weight molecules to lower weight molecules and a slower DOC reduction rate than humic acid degradation rate. (Eggins, Palmer & Byrne 1997). In most of the mentioned studies however, complete mineralization of organics was not achieved and different amounts of low weight molecules were left and not degraded even after reaction times as high as 240 min. Addition of H<sub>2</sub>O<sub>2</sub> can be used for expedited organic degradation by catalyzing HO· formation (Liu et al. 2008a)

### 2.1.1.3 TiO<sub>2</sub>-UV Effect on Inactivation of Microorganisms

Extensive research has been performed to study the efficacy of TiO<sub>2</sub>-based AOPs toward inactivation of microbes, including bacteria (Ireland et al. 1993, Chai, Lee & Kim 2000, Rincón, Pulgarin 2003, Benabbou et al. 2007), viruses (Sjogren, Sierka 1994, Guimarães, Barretto 2003, Gerrity et al. 2008, Liga et al. 2011, Nakano et al. 2012, Lee, Ko 2013), and protozoa (Lee et al. 2004, Lonnen et al. 2005, Ryu et al. 2008, Sökmen, Değerli & Aslan 2008, Navalon et al. 2009, Sunnotel et al. 2010, Peng et al. 2010, Abeledo-Lameiro, Ares-Mazás & Gómez-Couso 2016).

TiO<sub>2</sub>-UV photocatalysis applications can be deployed in different ways. Regardless, numerous studies have confirmed higher inactivation levels of microorganisms by TiO<sub>2</sub>-driven photocatalysis compared to UV. Some variables of TiO<sub>2</sub>-UV experiments/ applications reported in literature are 1) the crystalline form of TiO<sub>2</sub> nanoparticles, 2) type of the reactor, 3) modification of the nanoparticle surface, 4) immobilization of nanoparticles and 5) light source.

After photocatalytic capability of TiO<sub>2</sub>-UV to degrade and mineralize organics was discovered and documented, John C. Ireland et al were among the first groups of people who studied photocatalytic inactivation of *E. coli* using anatase TiO<sub>2</sub>, coated on a fiberglass mesh attached inside a UV chamber (Ireland et al. 1993). They observed 7 logs of *E. coli* inactivation under 9 minutes and reached non-detectable levels which is significant for a UV lamp that emits lights with wavelength between 300 to 400 nm (Ireland et al. 1993).

Subsequently, more scholars researched effects of different variables of TiO<sub>2</sub>-UV applications specifically on *E. coli* inactivation (Benabbou et al. 2007, Chai, Lee & Kim

2000, Cho et al. 2004, Cho et al. 2005, Rincón, Pulgarin 2003). Chai et al observed an optimum TiO<sub>2</sub> concentration and UV intensity of 100 mg/L and 50 W/m<sup>2</sup> respectively which resulted in 100% inactivation of cells in under 3 minutes that was 27 times faster than UV inactivation (Chai, Lee & Kim 2000). Dose optimization of TiO<sub>2</sub>-UV disinfection is still a subject of debate and there is contrary information available because different factors are involved, making each application unique. For instance, Benabbou et al found 250 mg/L of TiO<sub>2</sub> in combination with UV to achieve fastest *E. coli* inactivation in their experiments (Benabbou et al. 2007), while Chai and coworkers found the optimum TiO<sub>2</sub> dose in suspension for photocatalytic *E. coli* inactivation to be 100 mg/L (Chai, Lee & Kim 2000). This difference stems from different *E. coli* strain and type of UV lamps used. Optimum dose of TiO<sub>2</sub> seems to be dependent on various factors such as bacteria strain, UV light, TiO<sub>2</sub> form, reactor configuration, and water quality parameters.

Nevertheless, a linear correlation was found between OH<sup>·</sup> concentration and *E. coli* inactivation (Cho et al. 2004). Later on, Cho et al discovered that free radicals in solution bulk and surface-bound hydroxyl radicals can contribute to *E. coli* inactivation, while MS-2 phage is mainly inactivated only by free radicals in bulk solution (Cho et al. 2005). For this specific reason, implementing TiO<sub>2</sub> nanoparticles in suspension could be beneficial, although they need to be removed from effluent after the treatment process which can be costly.

Although a variety of viruses with different characteristics are inactivated by higher degrees when exposed simultaneously to TiO<sub>2</sub> and UV light rather than UV alone, some viruses like bacteriophage fr that is susceptible to UV, did not exhibit any inactivation improvement when treated by TiO<sub>2</sub>-UV photocatalysis (Gerrity et al. 2008).



Surface modification of TiO<sub>2</sub> (eg. By iron or silver doping) is also shown to significantly enhance virus inactivation rate (Sjogren, Sierka 1994, Liga et al. 2011). TiO<sub>2</sub> is also proven to show higher synergy on virus inactivation in combination with less germicidal lights such as UVA and UVB compared to UVC (Lee, Ko 2013) which is not as practical for utilities since almost all existing water utilities employ UVC spectrum to take full advantage of its high disinfecting capability.

Limited publication is available on photocatalytic inactivation of *Salmonella typhimurium* phage, P22. Guo et al developed a photocatalytic membrane reactor (PMR), consisted of a germicidal UV lamp (UVC) and TiO<sub>2</sub> tubular ceramic micro filters to study P22 inactivation by a PMR for the first time. They observed more than two times higher log reduction of P22 by UV-TiO<sub>2</sub> coated membrane compared to either UV and coated membrane processes in series or simultaneous UV-uncoated membrane process (Guo et al. 2015). Overall, 5 logs of P22 reduction was achieved using the photocatalytic membrane reactor (Guo et al. 2015).

#### 2.1.2 Peracetic Acid (PAA)-UV

Peracetic acid (CH<sub>3</sub>CO<sub>3</sub>H) which is sometimes referred to as peroxyacetic acid (PAA) is a corrosive and colorless weak acid with a strong oxidant-like smell (Koivunen, Heinonen-Tanski 2005a). It is an organic compound and is documented to generate hydroxyl radicals (OH·) when exposed to light with wavelength under 300 nm (Rokhina et al. 2010). Aside from water and wastewater industry, PAA has been used as a disinfectant or sterilizer in various other industries including food, beverage, medical, pharmaceutical, textile, pulp and paper (Kitis 2004, Koivunen, Heinonen-Tanski 2005a). Peracetic acid has been approved by US EPA as one of five alternative disinfectants to

chlorine for combined sewer overflow (CSO) treatment (US EPA. 1999). Commercial PAA is usually produced by adding hydrogen peroxide to acetic acid.



#### 2.1.2.1 Peracetic Acid (PAA)-UV Mechanism

The exact photocatalysis reactions/ mechanisms attributed to PPA and UV light leading to formation of hydroxyl radicals have not been thoroughly studied as they have been for other photocatalysts such as  $\text{H}_2\text{O}_2$  and  $\text{TiO}_2$  (Caretti, Lubello 2003a, Rajala-Mustonen, Toivola & Heinonen-Tanski 1997, Rokhina et al. 2010). However, scientists have hypothesized that following reactions take place and result in direct and indirect generation of hydroxyl radicals. (Caretti, Lubello 2003b)

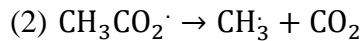
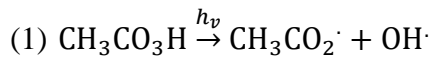

After the first and direct round of hydroxyl radical formation, PAA molecules react with them and generate more free radicals, according to the reactions below.

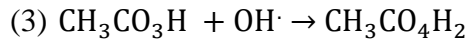

Additionally, presence of  $\text{H}_2\text{O}_2$  in equilibrium in commercial PAA solutions contribute to additional formation of  $\text{OH}\cdot$ . Likewise, overall hydroxyl radical formation by  $\text{H}_2\text{O}_2$ -UV processes goes into a cycle, meaning that first round of directly-formed hydroxyl radicals react with other  $\text{H}_2\text{O}_2$  molecules and generate water and hydroperoxyl ( $\text{OOH}$ ) which can then produce  $\text{H}_2\text{O}_2$  and  $\text{OH}\cdot$  (Caretti, Lubello 2003a).

#### 2.1.2.2 Peracetic Acid (PAA) Effect on Organic Degradation

In contrast to TiO<sub>2</sub>-UV AOPs, limited data is available on effect of PAA-UV AOPs on organic degradation. Some studies have shown fast degradation of 4-chlorophenol (4-CP) by 98% using PAA where formation of intermediates were observed with no residual of PAA (Sharma, Mukhopadhyay & Murthy 2010, Sharma, Mukhopadhyay & Murthy 2012).

A major advantage of using PAA as an alternative disinfectant is that it has not been associated with formation of detrimental by products (Liberti, Notarnicola 1999, Veschetti et al. 2003, Crebelli et al. 2005). In one study, adding 1.5 mg/L of PAA in wastewater did not form any THMs, while injecting 0.7 mg/L of chlorine, resulted in an increase in THM levels. Also, PAA did not cause any increase in concentrations of dichlorobromomethane, dibromochloromethane, chloroform, and broform, whereas applying chlorine contributed to yielding higher concentration for all of the mentioned compounds (Block, Reimers & Xu 2015).

Nevertheless, Booth and Lester demonstrated that “electrochemistry of PAA is sufficient to oxidize bromide to hypobromous acid and subsequently form brominated organics” (Booth, Lester 1995).

#### 2.1.2.3 Peracetic Acid (PAA)-UV Effect on Inactivation of Microorganisms

Peracetic acid has been studied both as a primary disinfectant on primary, secondary, and tertiary wastewater effluents and in combination with UV as a photocatalyst (Kitis 2004, Beber de Souza et al. 2015).

Although PAA can perform as a sufficient primary disinfectant at elevated Ct values, viruses have shown higher resistance in comparison with bacteria to PAA (Kitis

2004). For example, a PAA Ct value of 405 min-mg/L (15 mg/L PAA+ 27 min contact time) resulted in 3.9 logs of total coliform inactivation from a primary wastewater effluent while only 0.8 log inactivation of F-RNA phage was achieved for the exact same condition (Koivunen, Heinonen-Tanski 2005a). Poliovirus is also reported to require 15 minutes of contact time to PAA doses of up to 1500 mg/L which is substantial for 4 logs reduction (Baldry, French 1989). Luukkonen et al, also studied *E. coli*, total coliform, and coliphage reduction from a tertiary wastewater effluent by PAA and they similarly observed much higher bacterial reduction with lower PAA concentration compared to coliphages (Luukkonen et al. 2014). Almost 2 logs of inactivation was achieved for both *E. coli* and total coliforms by 30 min-mg/L of PAA as opposed to 1800 PFU/100 mL reduction of coliphages by PAA Ct value of 240 min-mg/L. A decrease in microbial inactivation was also observed by increased organic concentration (Luukkonen et al. 2014).

In general, inactivation synergy resulting from PAA-UV (PAA dosed upstream of UV light) advanced oxidation is much greater for bacteria compared to viruses. (Koivunen, Heinonen-Tanski 2005b). Doses of PAA as small as 2 ppm applied either just upstream of UV light with contact times less than 10 seconds or simultaneously to UV light is shown to enhance UV inactivation of total coliform, fecal coliform, and *E. coli* to non-detectable levels from secondary wastewater effluents (Caretto, Lubello 2003a, Madrid, Oleszkiewicz 2005). Water utilities therefore can potentially save energy and reduce their disinfection cost by applying small concentrations of PAA upstream of existing UV units and therefore shortening their UV contact time, while still in compliance with disinfection requirements.

With regard to photocatalytic inactivation of viruses by PAA-UV, combined PAA-UV process in some studies achieved even lower inactivation than sum of inactivations achieved by the same doses of PAA and UV, separately applied (Koivunen, Heinonen-Tanski 2005b). Even in cases where the inactivation synergy for viruses by simultaneous PAA-UV was positive, it was not a significant increase (Koivunen, Heinonen-Tanski 2005b, Beber de Souza et al. 2015). Koivunen et al observed a negative inactivation synergy for coliphage MS2 when 1.5 mg/L of PAA was injected upstream of UV doses of 8 and 10 mJ/cm<sup>2</sup> (Koivunen, Heinonen-Tanski 2005b).

However, In 1997, Rajala-Mustonen et al studied the effect of PAA-UV advanced oxidation on coliphage removal from wastewater and compared it to either UV or PAA inactivation (Rajala-Mustonen, Toivola & Heinonen-Tanski 1997). Inactivation time required to achieve more than 6 logs and 4 logs of DNA- and RNA-phages was reduced to 12.5 minutes respectively when PAA-UV was applied as opposed to 1 hour by PAA (Rajala-Mustonen, Toivola & Heinonen-Tanski 1997). Nonetheless, the synergy of PAA-UV compared to UV inactivation was not as considerable as it was compared to PAA inactivation (Rajala-Mustonen, Toivola & Heinonen-Tanski 1997).

Moreover, it is noteworthy to mention that as expected PAA-UV AOP is shown to have higher disinfecting capability than H<sub>2</sub>O<sub>2</sub>-UV (Lubello, Caretti & Gori 2002).

## CHAPTER 3

### METHODOLOGY

#### 3.1 UV Devices Used in This Study

Included in this work were three UV units with design specifications for three different applications. A collimated beam apparatus was used as a bench scale device and acted as a proof of concept for pilot-scale experiments. Commercially available units, Photo-Cat from Purifics and D222 unit from NeoTech Aqua Solutions were used for application of AOP disinfection of water and wastewater, respectively. Detailed description of these devices are provided in the following sections.

##### 3.1.1 Collimated Beam Apparatus

A 18-inch, 15-watt, low-pressure, mercury arc lamp (USHIO, G15T8, Asbury Park, NJ) was placed in a 26 \* 57 cm wooden box positioned on top of a collimating tube (61 cm long with a diameter of 5.1 cm) to provide spatially homogeneous irradiation on the samples with standardized parallel rays of germicidal light. The wavelength of light produced by the lamp was 253.7 nm which falls into the UV-C spectrum, which is known to be the most potent germicidal spectrum of UV radiation. It can excite the electron on the valence band and activate TiO<sub>2</sub> band gap of 3.2 eV. The collimating tube was 61 cm in length and 5.1 cm in diameter. The platform for holding sample petri dishes was adjusted to have a 1-cm distance from the end of the collimating tube and the surface of the samples in petri dishes. The irradiance (intensity) of the UV lamp was measured using a 2048L AvaSpec radiometer (AVANTES, Netherlands) by placing the detector 1 cm right below the collimating tube in the center. The irradiance was measured after a 15-min warm-up for the UV lamp and before each experiment. To ensure consistency of

lamp irradiance, the lamp has not been displaced throughout all the experiments conducted. A schematic and a real picture of the collimated beam apparatus is provided below.

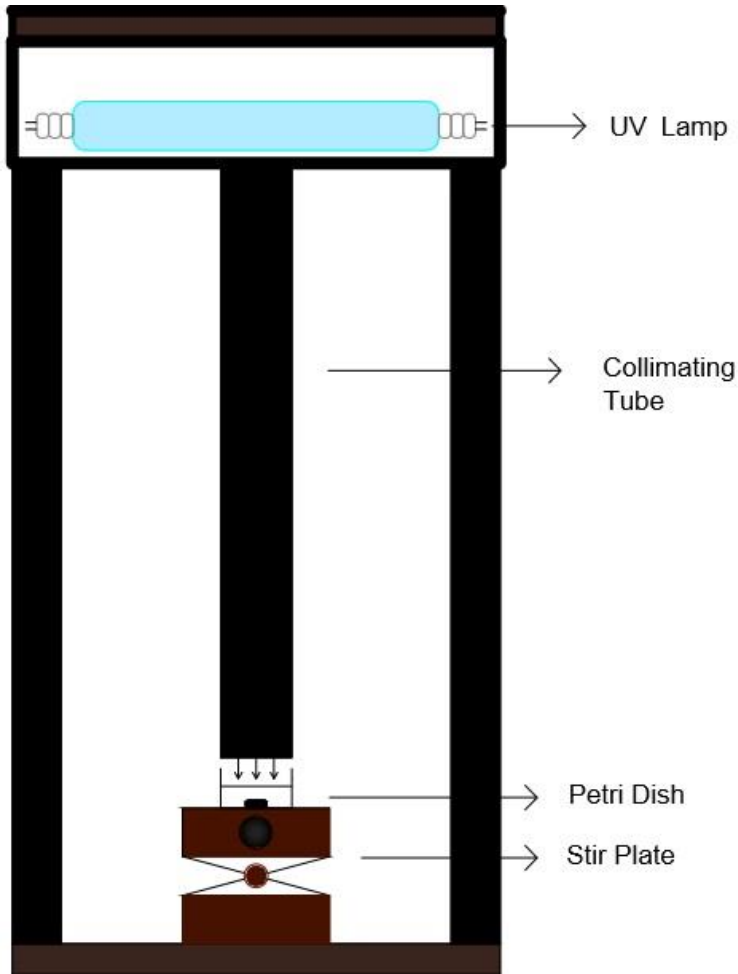

Figure 1. Schematic of the Collimated Beam Apparatus



Figure 2. Picture of the Collimated Beam Apparatus Used in this Study



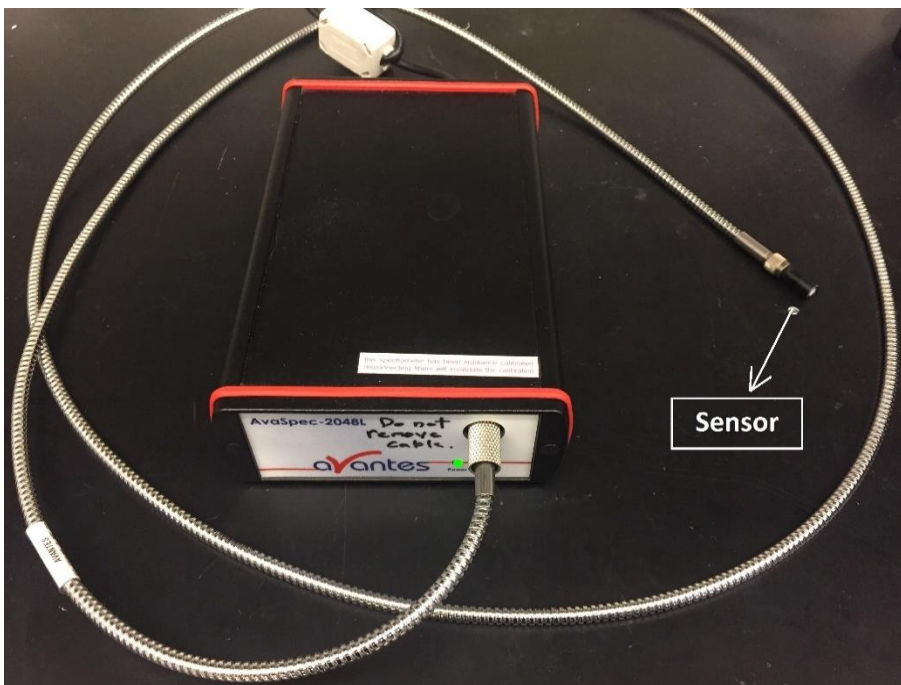

Figure 3. AvaSpec Radiometer from Avantes

#### 3.1.1.1 Procedure for Conducting Experiments using Collimated Beam Apparatus

Experiments were performed in 20 mL of 0.5 X phosphate buffered saline (PBS) with pH adjusted at 7.5 in sterilized borosilicate glass petri dishes (60 × 15 mm) (Radnor, PA, USA). The UV lamp was turned on 15 minutes prior to starting experiment that allowed lamp to warm up and reach stable intensity. In the meantime, the test samples were prepared by adding desired volume of PBS, target microorganism (based on the overnight/ stock concentration) and photocatalyst, either TiO<sub>2</sub> or PAA and allowed to mix for two minutes. Then 3 mL aliquot was collected from the petri dish to determine the initial concentration of microorganisms. After UV warm-up period, the petri dish is placed under the collimating tube and the stopwatch is started at the same time. During the experiment, sample was continuously stirred at a low-speed using Corning magnetic stirrer and an 8 × 1.5 mm Teflon-coated stirring bar. The subsequent aliquots were

collected in 15 mL tubes at pre-determined time intervals and assayed after the experiment. The 15 mL tubes used for collection of aliquots/ samples (from PAA experiments) contained 20  $\mu$ L of sodium thiosulfate (50 mg/mL) to quench any possible PAA residual immediately after the sample collection. The irradiance of the UV lamp was measured for each experiment and the average irradiance was adjusted according to Bolton and Linden to be 0.04 mW/cm<sup>2</sup> (Bolton, Linden 2003). The UV radiant exposure (dose) then was calculated for each sample using the formula below.

$$\begin{aligned}
 \text{UV Radiant Exposure } \left( \frac{\text{mJ}}{\text{cm}^2} \right) \\
 = \text{UV Irradiance } \left( \frac{\text{mW}}{\text{cm}^2} \right) \times \text{Exposure Time (s)}
 \end{aligned}$$

A detailed and step by step calculation of the average UV irradiance is provided below.

$$I_{\text{average}} = I_0 \times \text{Reflection Factor} \times \text{Petri Factor} \times \text{Water Factor} \times \text{Divergence Factor}$$

Where:

$$I_{\text{average}} = \text{Average Corrected Irradiance}$$

$$I_0 = \text{Average Measured Irradiance}$$

Reflection factor accounts for the portion of the light reflected off the interface between air and water due to the refractive index change and it is 0.975 for those two media. The petri factor corrects the variation in irradiance reading across the surface of the water by measuring the irradiance at different locations and dividing them by the irradiance in the center and then averaging the final values. The petri factor was calculated to be 0.96. The water factor was determined to be 0.99 by  $WF = e^{-l\alpha(\lambda)}$  where  $l$  is the sample depth which was 0.95 (cm) and  $\alpha(\lambda)$  is sample absorbance in (cm<sup>-1</sup>)

which was less than  $0.01 \text{ cm}^{-1}$ . The divergence factor accounts for light divergence through collimating tube and is calculated by  $\frac{L}{L+l}$  where  $L$  is the distance from the UV source to the surface of the cell suspension and  $l$  is the water depth. It was determined to be  $\frac{62}{62.95} = 0.98$ . Ultimately, the average corrected UV irradiance is calculated to be  $0.0395 \text{ mW/cm}^2$ .

$$I_{\text{average}} = 0.044 \times 0.975 \times 0.96 \times 0.99 \times 0.98 = 0.04 \left( \frac{\text{mW}}{\text{cm}^2} \right)$$

### 3.1.2 Purific Photo-Cat

Photo-Cat lab serial 0700 from Purifics (London, ON, Canada) was selected due to its proven capability of removing contaminants and tailored design for nanoparticle-based advanced oxidation processes to carry out  $\text{TiO}_2$ -UV experiments to investigate photocatalytic inactivation of bacteriophage P22 at a pilot scale (Mayer, Daugherty & Abbaszadegan 2014, Stancl, Hristovski & Westerhoff 2015, Gerrity et al. 2008). The Photo-Cat 0700 consisted of four 220-Watt, low-pressure UV lamps in series and a ceramic membrane filter. The UV lamps emit light at 253.7 nm which is the most potent germicidal wavelength to microbes. The integrated ceramic membrane filter recirculates  $\text{TiO}_2$  nanoparticles through the UV system and produces  $\text{TiO}_2$ -free effluent. An air compressor oxygenates the Photo-Cat by introducing a burst of air every minute that helps recirculating  $\text{TiO}_2$  further in the system. The effluent sampling port is placed right above the submicron-sized ceramic membrane filter and the effluent flow when taking samples, is perpendicular to the process flow. Below are schematic and real picture of Photo-Cat.

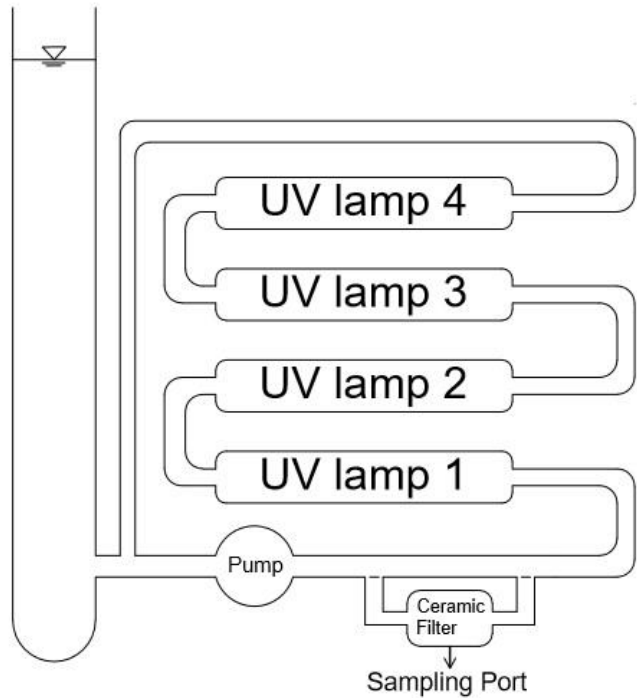

Figure 4. Schematic of Photo-Cat from Purifics

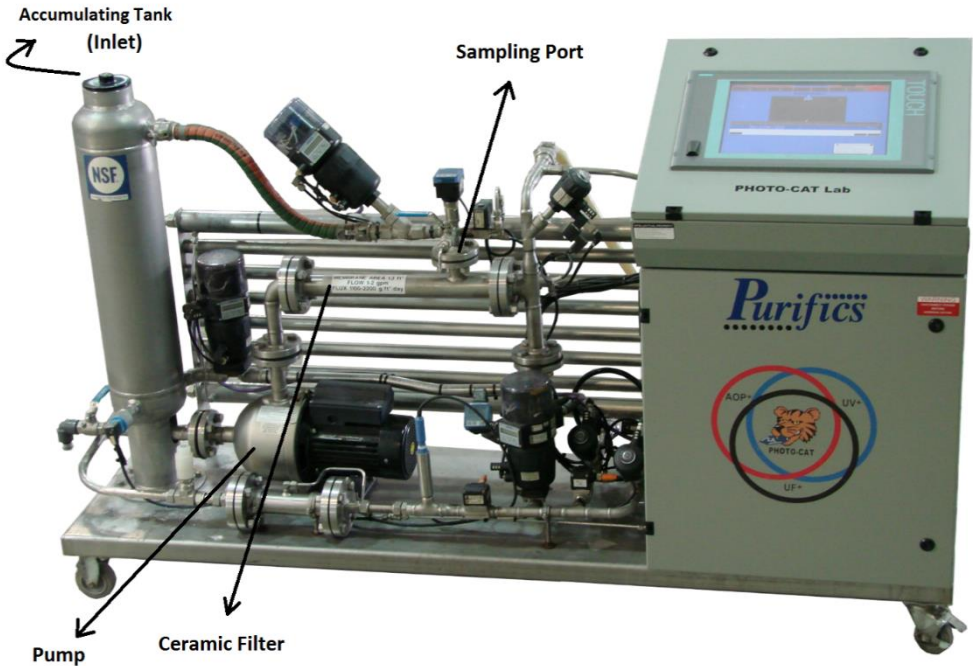

Figure 5. Picture of Photo-Cat system from Purifics used in this study

### 3.1.2.1 Experimental Procedure using Purifics Photo-Cat

All the experiments were conducted using reverse osmosis (RO) water. The pH of the test water was not adjusted but was measured before and after each experiment. An automated process control board on the system allows to control the hydraulics and the UV lamps status. The flowrate was set at 20 L/min with 10 L of total volume of water. At least 175 L deionized (DI) water was purged through Photo-Cat system before and after each experiment to prevent cross-contamination and any possible interference from previous experiments. The samples were prepared by adding desired amount of bacteriophages and TiO<sub>2</sub> powders to 10 liter of RO water and thoroughly mixed. All four UV lamps were switched on for all the experiments and were allowed to warm up for 20 minute prior to adding the samples into the system. During both the warm up period and experiments, the cooling water valve was opened and run across the lamps to avoid overheating the UV lamps and maintaining the experiment temperature at around 26 degree Celsius. Following the warm up period, the cooling water and all UV lamps were turned off and the sample was added to the accumulation tank and the system was run in batch mode for one minute to allow enough mixing. Then 30 mL of sample was collected after flushing out 750 mL from the sampling port and was regarded as the influent sample. Immediately after the influent sample was taken, the UV lights were turned on and the cooling water valve was opened again and 30 mL of sample aliquots were taken at specified time intervals. All the samples were assayed for bacteriophage using double-agar layer method afterwards. In addition, turbidity and pH of the samples were also measured.

### 3.1.3 D222 UV Unit from NeoTech Aqua Solutions

The UV system model D222, provided by NeoTech Aqua Solutions (San Diego, CA) was used for pilot-scale PAA-UV experiments and is rated for up to 35 gallons per minute of flow. It is connected to a digital UV intensity detector that continuously displays the real time UV intensity in the reactor. The unit consists of a single 22-inch, 98-Watt low pressure lamp and maximizes UV light dispersal and consequently exposure inside the chamber due to its patented 99.8% reflective chamber. A schematic and a picture of the D222 UV unit is provided below (Figures 6 and 7).

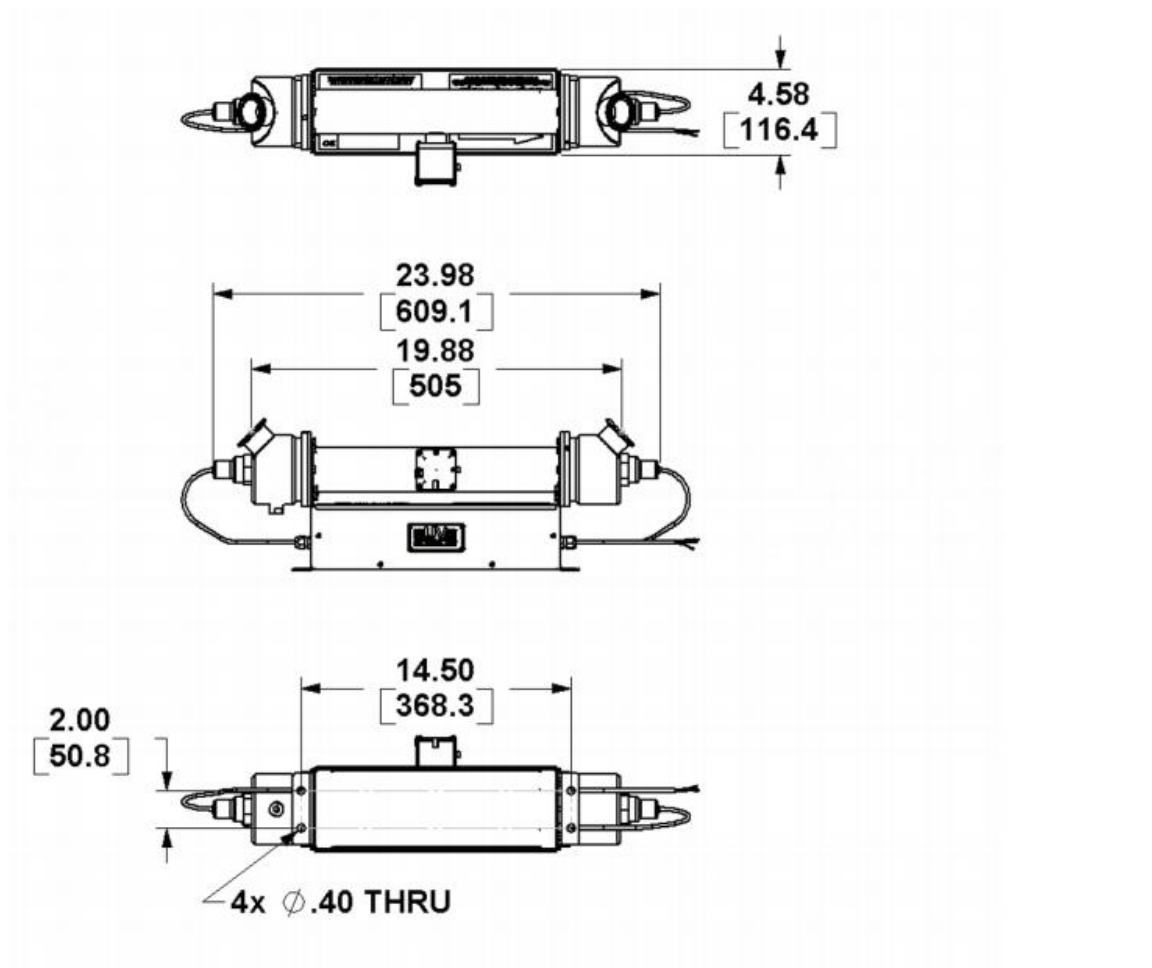

Figure 6. Schematic of D222 UV Unit from NeoTech Aqua Solutions

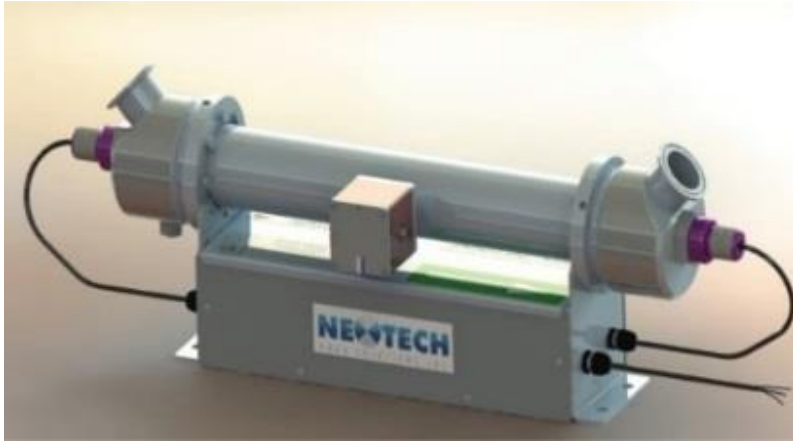

Figure 7. Picture of D222 UV Unit, from NeoTech Aqua Solutions website

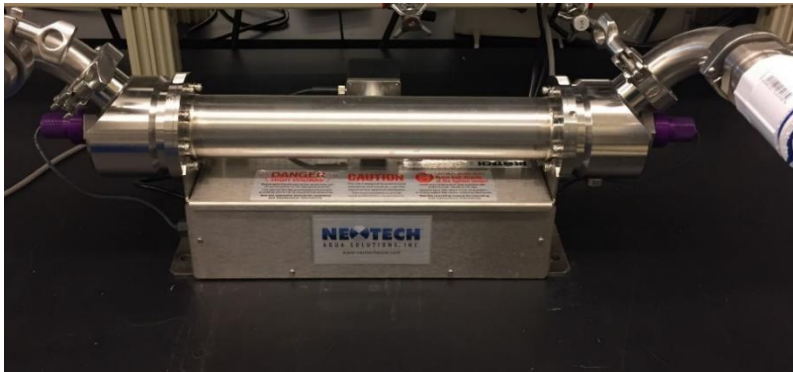

Figure 8. Picture of D222 UV unit used in this study



Figure 9. Close-Up view of D222 UV device control box

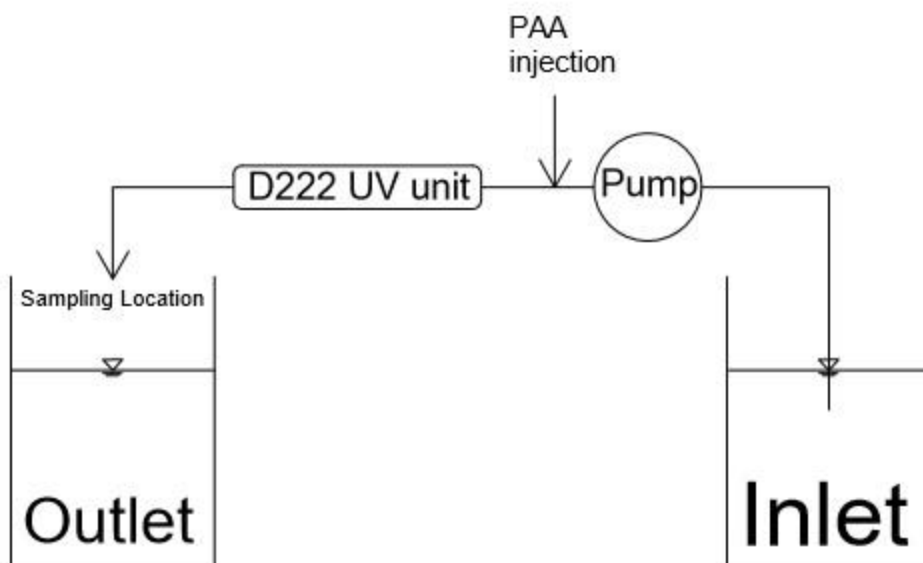

Figure 10. Schematic of Pilot-scale PAA-UV AOP Experiments Setup

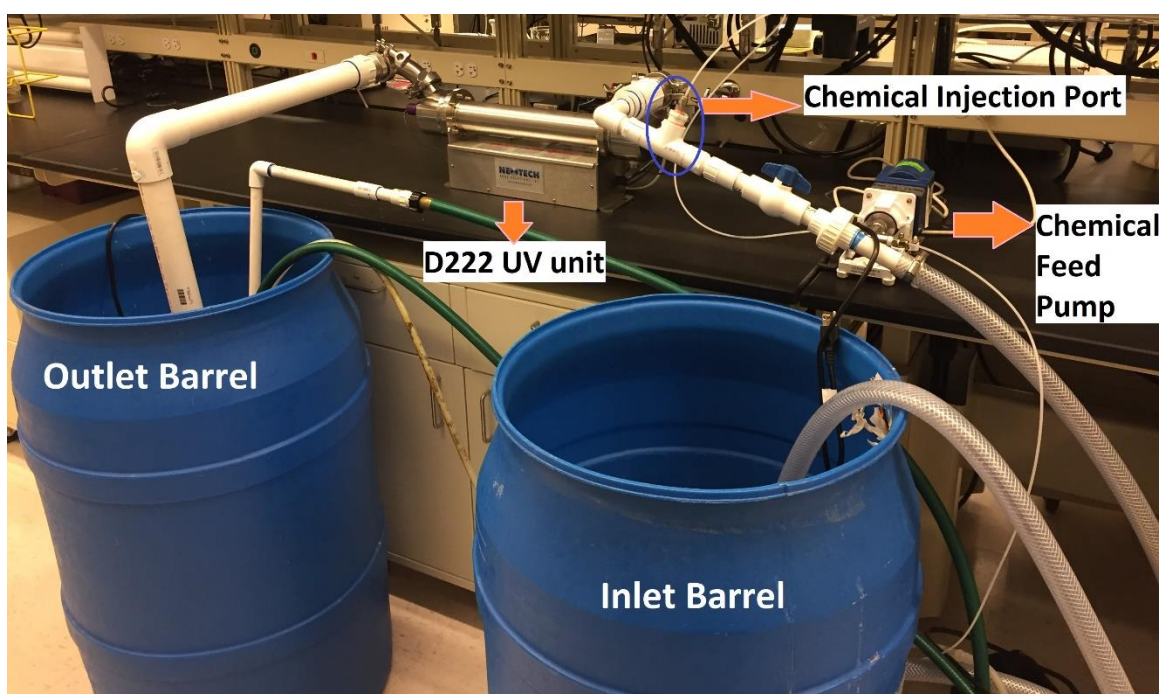

Figure 11. Picture of pilot-scale PAA-UV AOP experiments setup



### 3.1.3.1 Experimental procedure using D222 UV unit

Experiments performed using D222 UV unit were aimed to address P22 and *E. coli* inactivation by PAA-UV advanced oxidation processes for wastewater treatment applications. The centrifugal 2851-6 pump from AMT Pump (Model C63JXGWU-1114) (Royersford, PA, USA), inlet and outlet barrels and the UV unit were connected by PVC piping and fittings. A chemical feed low slow- low flow pump (model QG50) from Fluid Metering, Inc (Long Island, New York, USA) was used to inject PAA through a chemical injection port designed upstream of the NeoTech UV device. This allowed mixing of peracetic acid in the influent prior to UV exposure.

Before each experiment, the UV lamp was turned on for 10 minutes to warm up and reach a constant intensity. In the meantime, the UV unit and quartz sleeves were cleaned thoroughly using tap water several times. Then, the inlet barrel was filled to approximately 200 liters of tap water. After that, 1 mL of sodium thiosulfate (50 mg/mL) was added to the water in the inlet tank in order to neutralize chlorine residual in tap water. Subsequently, chlorine-free water in the inlet tank was spiked with certain amounts of *E. coli* and/or P22 stock solutions at the same time to reach desired initial concentrations and the whole solution was thoroughly mixed with a submersible pump (model, company, city, state) for 3 minutes. After 3 minutes of mixing, inlet samples were taken directly from the inlet barrel in pre-ashed amber bottles. The next step was to turn the chemical feed pump on first to ensure PAA reaches the inlet water and then the inlet water was immediately ran through the UV devie- D222 unit and outlet samples were collected from the outlet PVC pipe in pre-ashed amber bottles. The bottles used for collection of samples contained 50 microliter of sodium thiosulfate (50 mg/mL) to

quench any possible PAA residual immediately. Samples were analyzed for detection and quantification of *E. coli* and P22. In addition, the experiments were run again under the same condition to analyze pH, PAA residual, dissolved organic carbon (DOC), UV transmittance (UVT), and turbidity.

### 3.2 Microorganisms; Preparation and Assay

The pure cultures of microorganisms used in this study were obtained from American Type Culture Collection (ATCC, Rockville, MD) and were propagated according to the instructions provided.

#### 3.2.1 *E. coli*

*Escherichia coli* (ATCC® 25922™) was propagated and assayed in duplicates using either spread plate method or membrane filtration method, depending on volume of the sample needed for any specific experiment.

For *E. coli* enumeration, Brilliance media (Brilliance Green Bile *E. coli*/ Coliform Media Catalog #B1802, Sigma Aldrich) was used and prepared according to the manufacturer instructions. Briefly, samples were serially diluted (by factor of 10) to desired degrees in 0.5X PBS. Then either 0.1 or 0.5 mL from an appropriate diluted sample was dispensed onto the Brilliance plates and was spread evenly using a sterilized spreader on the surface of the media. Then the plates were incubated inverted at 37 °C for 20 hours and the colonies were counted afterwards. Based on the dilution factor and number of colonies, concentration of the original sample was calculated as CFU/mL.

Membrane filtration was used for 100 mL of sample when no colonies were detected on the plates by spread plate method by which either 0.1 or 0.5 mL of the sample is tested.

An example of a brilliance plate with *E. coli* colonies formed on it is provided in Figure 12.

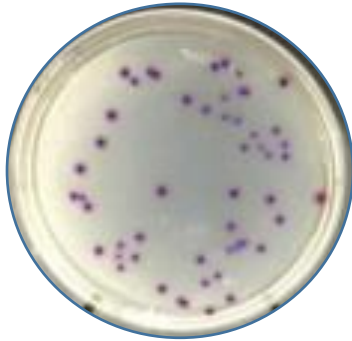

Figure 12. *E. coli* colonies grown on Brilliance media

### 3.2.2 P22

Bacteriophage P22 (ATCC® 19585-B1™) was propagated and assayed in duplicates using double agar layer (DAL) method. (Bacteriophages 1959, Abbaszadegan et al. 2007)

*Salmonella typhimurium* (ATCC® 19585™) was used as the host bacterium for bacteriophage P22 enumeration. In brief, samples were serially diluted (by factor of 10) to desired degree in 0.5X PBS. Then, 1 mL of the diluted sample and 1 mL of host cell bacteria in the log-phase of growth were mixed with 5 mL of 0.7% molten tryptic soy agar (TSA) (St. Louis, MO, USA) which was kept in a water bath at 48 °C, and the mixture was gently poured onto 1.5% TSA plates. Plates were allowed to sit undisturbed to let the top agar to solidify on the bottom agar. Then, the plates were incubated upside down at 37 °C and plaques were counted after at least 12 hours of incubation. In addition for every DAL assay, positive and negative controls were included.

An example of a TSA plate with P22 plaques formed on it is provided in Figure 13.

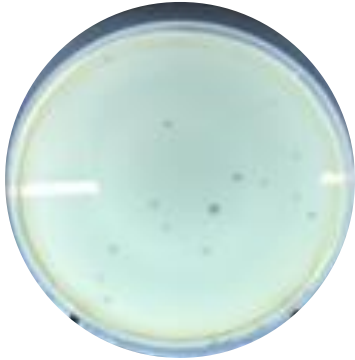

Figure 13. P22 Plaques formed on *Salmonella* lawn

### 3.3 Titanium Dioxide (TiO<sub>2</sub>)

Titanium dioxide (TiO<sub>2</sub>) is a semiconductor nanopowder which exhibits photocatalytic capabilities under UV light and potentially other light sources, depending on the phase of the particles. Commercial TiO<sub>2</sub> nanoparticles come in different crystalline forms and the stock used in this work was Aeroxide P25 (CAS number 13463-67-7, SKU: 718467) obtained from Sigma Aldrich (St. Louis, MO, USA). It contains anatase and rutile forms in a ratio of about 3:1 to make it more catalytic while increasing stability compared to either forms. The surface area of the powders are between 35 to 65 m<sup>2</sup>/g with primary particle sizes less than 21 nanometers. However, since TiO<sub>2</sub> nanoparticles tend to aggregate easily, the effective diameter in the solutions were measured and they were much bigger than indicated by the vendor (on the stock container). TiO<sub>2</sub> stock solutions were made according to the desired final concentrations for the bench-scale experiments and were not sonicated before the experiments. For pilot-scale TiO<sub>2</sub>-UV experiments, solid powders were weighted and added to RO effluent for corresponding concentrations.

### 3.4 Peracetic Acid (PAA)

Peracetic acid stock used in this work was obtained from Solvay Chemicals (Houston, TX, USA). It is a 12% PAA solution (Proxitane WW-12) that also contains 20% hydrogen peroxide ( $\text{H}_2\text{O}_2$ ), 20% acetic acid ( $\text{CH}_3\text{COOH}$ ), and water ( $\text{H}_2\text{O}$ ) all in equilibrium. The density of the 12% solution is 9.26 lbs/gal and it was used to make dilutions accordingly and reach the desired final concentrations in the inlet water considering the pump flowrates.

### 3.5 Water Quality Parameter Measurements

Certain water quality parameters were measured for each experiment to help analyze the results and be able to draw more precise conclusions.

#### 3.5.1 Dissolved Organic Carbon (DOC)

Dissolved organic carbon (DOC) concentrations of the samples from pilot-scale PAA-UV experiments were determined by Shimadzu model TOC-L CPH (catalogue # 638-91105-32, Kyoto, Japan). Samples were filtered using a syringe and a previously-ashed glass microfiber filters (Whatman, Catalogue # 1825-025, Maidstone, United Kingdom) into ashed 40-mL amber vials. Followed by acidification by adding 4 drops of 6N HCL to pH below 2, vials were put into the Shimadzu TOC analyzer.

#### 3.5.2 pH

To measure the pH of the samples, SevenExcellence pH meter (METTLER TOLEDO, Mesa, AZ, USA) was used and calibrated beforehand using standard solutions.

### 3.5.3 Turbidity

Turbidity of the samples were measured by portable turbidimeter model DRT – 15CE (HF Scientific, Inc, Fort Myers, FL, USA)

### 3.5.4 UV Transmittance (UVT)

Samples were prepared for UVT measurements the same way they were for DOC measurements. According to the standard methods, samples should be filtered to minimize the scattering of the light by suspended solids.  $UV_{254}$  was measured for each sample using HACH model DR 5000 (Loveland, CO, USA) and then converted to UVT by formula below:

$$\% \text{ UVT} = 100 \times 10^{-UVA}$$

$UVA = UV_{254}$  which is the portion of the light absorbed by the organics in the sample

### 3.5.5 Mean Effective Diameter of $TiO_2$ particles

Mean effective diameter of  $TiO_2$  particles for each concentration of  $TiO_2$  used to run bench-scale and pilot-scale  $TiO_2$ -UV AOP experiments were measured using ZetaPULSE device from Brookhaven Instruments Corporation (Holtsville, NY, USA).

## CHAPTER 4

### RESULTS AND DISCUSSION

#### 4.1 Bench-scale Inactivation Experiments

The main purpose of conducting the experiments using collimated beam apparatus in this work was to evaluate inactivation of *E. coli* and bacteriophage P22 separately by UV light and compare them with inactivation level by TiO<sub>2</sub>-UV and PAA-UV AOPs. These bench-scale experiments were perceived to serve as proof of concept for microbial inactivation by the treatment methods used.

In addition, inactivation of target microbes (*E. coli* and bacteriophage P22) by both UV light and AOPs (either TiO<sub>2</sub>-UV or PAA-UV) were assessed separately by two different commercially available pilot-scale units which will be discussed in the next section. Synergistic inactivation is defined by equation below.

Synergistic inactivation = AOP inactivation – (UV inactivation + TiO<sub>2</sub>/PAA inactivation)

All the raw data for all of the experiments conducted are also provided in the Appendix.

##### 4.1.1 Inactivation of *E. coli*, Using Collimated Beam Apparatus by UV or TiO<sub>2</sub>-UV

The log<sub>10</sub> inactivations of *E. coli* by TiO<sub>2</sub>-UV AOP, with different concentrations of TiO<sub>2</sub> using collimated beam apparatus is presented in Figure 13 and is compared to that of UV inactivation. The effect of TiO<sub>2</sub> on *E. coli* concentration in dark condition was also evaluated. Log<sub>10</sub> concentration of *E. coli* is plotted versus contact time (on upper secondary horizontal axis) with TiO<sub>2</sub> for the concentrations used in bench-scale AOP experiments. The intention was to eliminate any possible direct inactivation contribution

of TiO<sub>2</sub> from AOP synergy and to examine if TiO<sub>2</sub> particles affect bacterial detection and/ or quantification when spread plating is used to enumerate bacteria.

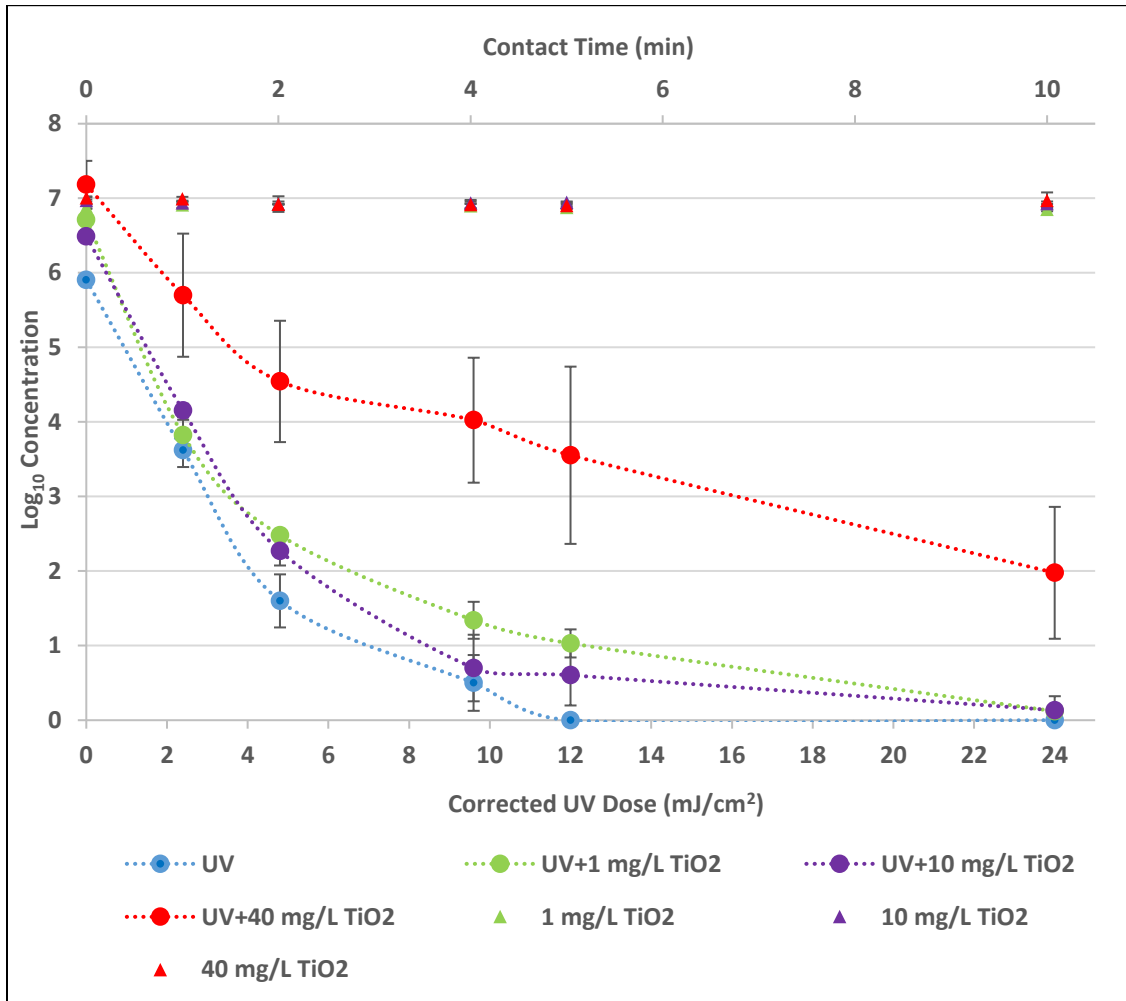

Figure 14. Bench-scale Inactivation of *E. coli* by UV or TiO<sub>2</sub>-UV

As it can be seen, when using collimated apparatus, the highest and lowest inactivation of *E. coli* is achieved by UV light and TiO<sub>2</sub> (40 mg/L)+UV, respectively. Almost 5.8 logs of *E. coli* was inactivated with UV dose of 9.6 mJ/cm<sup>2</sup> while 3.2 logs of *E. coli* inactivation was achieved by simultaneous treatment using TiO<sub>2</sub> (40 mg/L) and UV (9.6 mJ/cm<sup>2</sup>) which translates to an almost 45% drop in inactivation. It can also be observed that *E. coli* inactivation decreased consistently as TiO<sub>2</sub> dose increased. When



TiO<sub>2</sub> particles were applied to the slurry in dark room, they did not disrupt *E. coli* detection/ quantification even at the highest concentration of TiO<sub>2</sub> (40 mg/L) used.

#### 4.1.2 Inactivation of P22, Using Collimated Beam Apparatus by UV or TiO<sub>2</sub>-UV

The log<sub>10</sub> inactivations of P22 by TiO<sub>2</sub>-UV AOP, with different concentrations of TiO<sub>2</sub> using collimated beam apparatus is presented in Figure 14 and is compared to that of UV inactivation. The effect of TiO<sub>2</sub> concentrations used for bench-scale AOP experiments, on P22 detection for corresponding contact times to UV doses was also studied in dark condition. Log<sub>10</sub> concentration of P22 is plotted versus contact time (on upper secondary horizontal axis) with TiO<sub>2</sub> at concentrations used in bench-scale AOP experiments. The intention was to eliminate any possible direct inactivation contribution of TiO<sub>2</sub> by itself from AOP synergy and to see if TiO<sub>2</sub> particles affect bacteriophage detection and/or quantification when double-agar layer assay is used to enumerate bacteriophage P22.

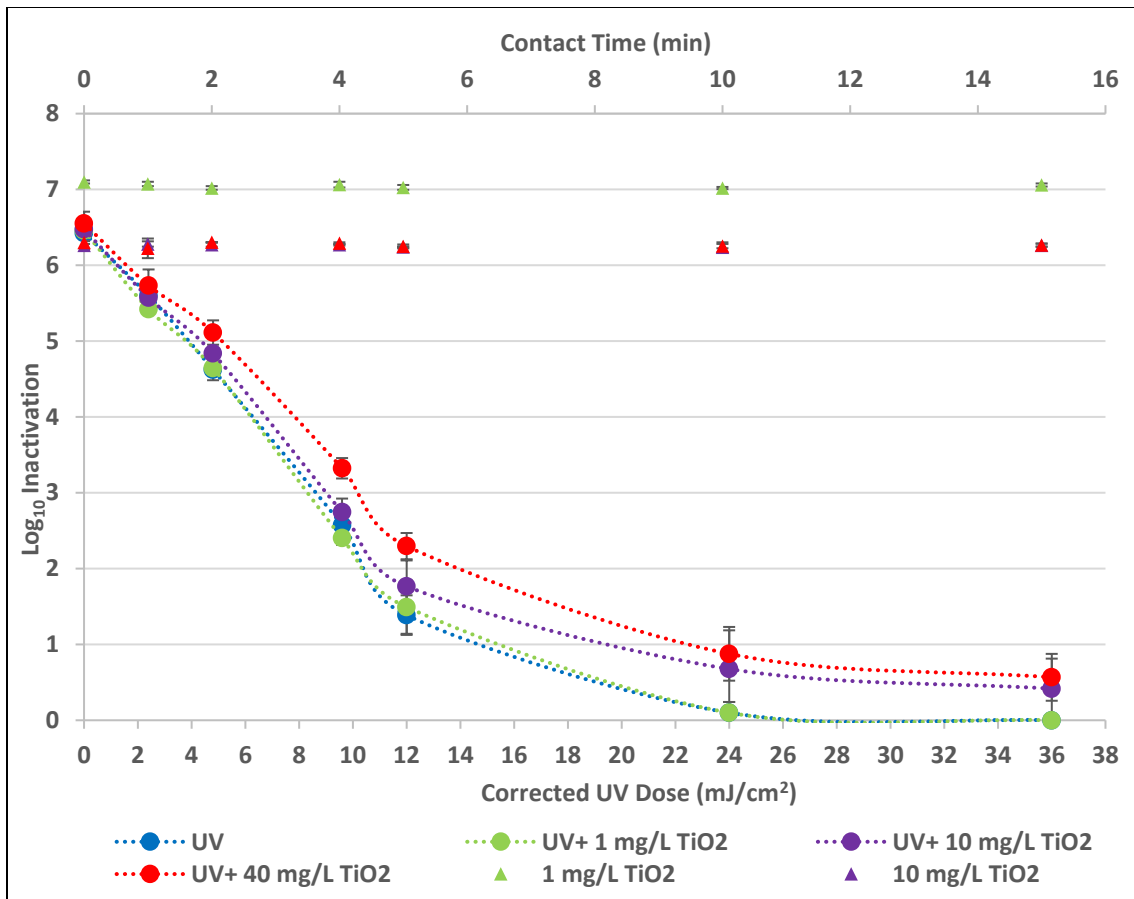

Figure 15. Bench-scale Inactivation of P22 by UV or TiO<sub>2</sub>-UV

With regard to TiO<sub>2</sub> concentration effect, P22 photocatalytic inactivation followed the same trend as *E. coli* photocatalytic inactivation did using collimated beam apparatus. In other words, P22 inactivation started to decline by implementing higher concentrations of TiO<sub>2</sub> nanoparticles. UV dose of 9.6 mJ/cm<sup>2</sup> resulted in 3.6 logs of P22 inactivation whereas 3.2 logs of P22 inactivation was achieved by simultaneous treatment using TiO<sub>2</sub> (40 mg/L) and UV (9.6 mJ/cm<sup>2</sup>). P22 appears to be more resistant to UV inactivation than *E. coli*. However, when TiO<sub>2</sub> (40 mg/L) and UV (9.6 mJ/cm<sup>2</sup>) were applied simultaneously to the reactor, P22 inactivation dropped by 11% compared to that of UV as opposed to 45% drop for *E. coli*.

TiO<sub>2</sub> nanoparticles did not impact bacteriophage detection/ quantification in dark condition by double-agar layer assay and no drop in plaque numbers was observed for any of the TiO<sub>2</sub> concentrations applied.

All bench-scale TiO<sub>2</sub> based AOP experimnt series, including *E. coli* and P22 inactivation series, were conducted in phosphate-buffered saline (PBS) in room temperature and several parameters were measured and are summarized in the table below:

Table 2. Water Quality Parameters for Bench-scale TiO<sub>2</sub>-UV AOP Experiments

TiO <sub>2</sub> concentration (mg/L)	TiO <sub>2</sub> particle size in the PBS (nm)	Turbidity (NTU)	UVT (%)	pH
0	-	1.0	83.9	7.5
1	2855.7	6.2	83.8	7.5
10	2993.7	27.5	84.2	7.5
40	1952.6	102.7	84.5	7.5

The pH of the solution remained constant during and after the experiments for all of the TiO<sub>2</sub>-UV experiments. The values in the table above are average of triplicates.

Applying TiO<sub>2</sub> nanoparticles simultaneously to UV radiation to the reactor, did not increase inactivation of either *E. coli* or P22 using collimated beam apparatus. In fact, highest TiO<sub>2</sub> concentrations (40 mg/L) resulted in the lowest inactivation levels for both *E. coli* and P22 in bench-scale experiments. Several hypotheses can be attributed to this

phenomena. As shown in other studies, one hypothesis for lower inactivation achieved by higher TiO<sub>2</sub> concentrations could be reduced direct UV exposure stemmed from high turbidity and consequent scattering and adsorption of light by TiO<sub>2</sub>, especially since TiO<sub>2</sub> particles size were measured to be on the order of couple of thousands nanometer in the buffer used (Benabbou et al. 2007, Rincón, Pulgarin 2003, Gerrity et al. 2008). Secondly, since aggregated TiO<sub>2</sub> particle sizes were much bigger than bacteria and viruses, it could be hypothesized that they form a layer around the microorganisms resulting in rendering a big portion of TiO<sub>2</sub> particles non-photocatalytic and therefore ineffective (Benabbou et al. 2007). Thirdly, if generated holes (on the valence band) and free electrons (on the conduction band) are not used by organics and microorganisms, they can quickly recombine with other TiO<sub>2</sub> particles, limiting hydroxyl radical generation (Benabbou et al. 2007). In general, by increasing TiO<sub>2</sub> concentration, turbidity of solution increases without necessarily contributing to hydroxyl radical formation to the same proportion.

Isoelectric point of P25 TiO<sub>2</sub> and P22 are ~6.4 and ~4.55, respectively and therefore at pH=7.5 they are both negatively charged on their surface (Cingolani et al. 2002, Long et al. 2006). However, the PBS used in the bench-scale TiO<sub>2</sub>-UV AOP experiments contains cations and can possibly neutralize the net negative charge of TiO<sub>2</sub> particles and P22 phages to some degrees, but pH adjustment may have been helpful to increase adsorption of microorganisms to TiO<sub>2</sub> particles and consequently improve photocatalytic inactivation and is worth of evaluation (Cho et al. 2005, Gerrity et al. 2008).

#### 4.1.3 Inactivation of *E. coli*, Using Collimated Beam Apparatus by UV or PAA-UV

The collimated beam apparatus was also used to study photocatalytic inactivation of *E. coli* by PAA-UV and compare it to UV inactivation of *E. coli*. In a similar manner to TiO<sub>2</sub> experiments, the possible effect of PAA on *E. coli* in dark condition was studied.

Log<sub>10</sub> concentration decay of *E. coli* by PAA-UV using collimated beam apparatus is presented and compared to that of UV in figure 15. Additionally, Log<sub>10</sub> concentration of *E. coli* when exposed to PAA in a dark room is plotted versus contact time on a secondary horizontal axis.

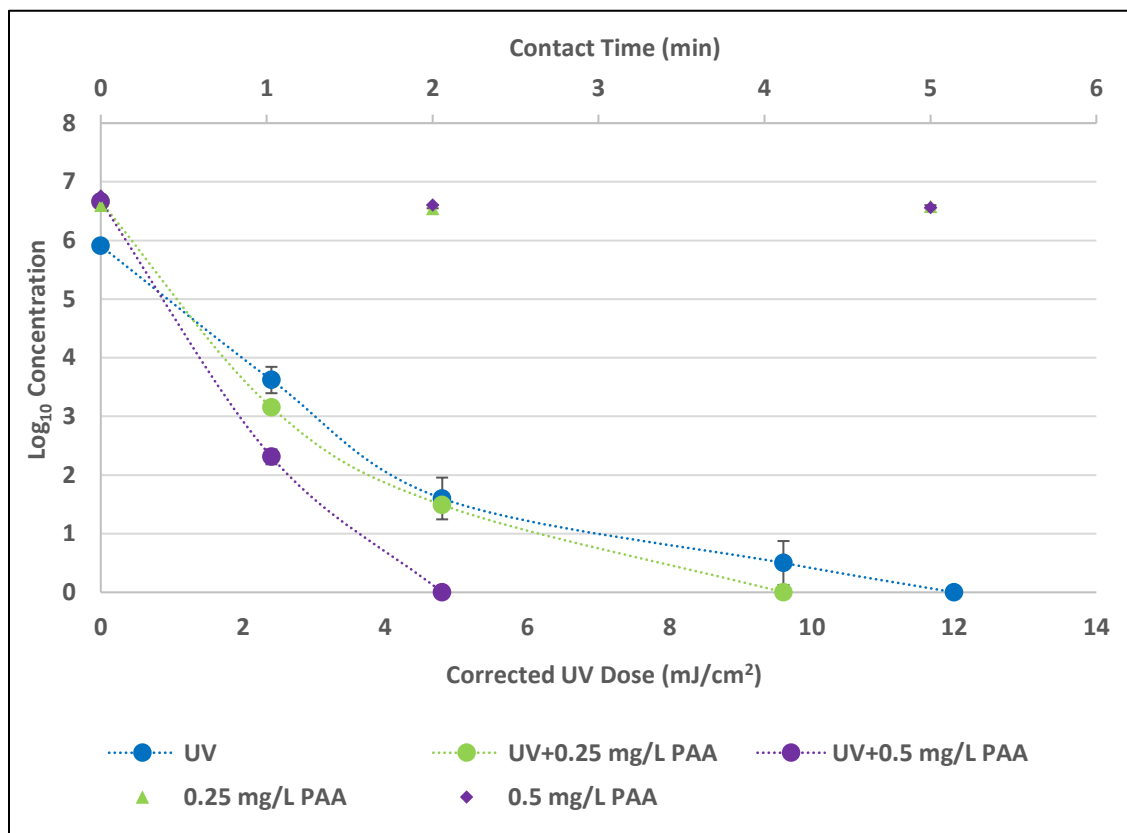

Figure 16. Bench-scale Inactivation of *E. coli* by UV or PAA-UV

It can be inferred from the graph that PAA at doses and contact times applied and without UV light did not affect *E. coli* concentration. However, applying 0.25 and

0.5 mg/L PAA to the reactor and exposing it to UV light, increased *E. coli* inactivation significantly by 53 and 90 percent, respectively and compared to *E. coli* inactivation achieved by UV at UV dose of 2.4 mJ/cm<sup>2</sup>.

Complete inactivation of *E. coli* with starting log concentrations of 5.9, 6.7, and 6.7 by UV, UV+PAA (0.25 mg/L), and UV+PAA (0.5 mg/L) were achieved in less than 5, 4, and 2 minutes, respectively, using collimated beam apparatus.

#### 4.1.4 Inactivation of P22, Using Collimated Beam Apparatus by UV or PAA-UV

Log<sub>10</sub> inactivation of P22 by PAA-UV AOP with different concentrations of PAA using collimated beam apparatus is presented in figure 16 and is compared to that of UV inactivation. Like all other bench-scale AOP experiments conducted in this study, The effect of photocatalyst (PAA) on possible degradation of P22 in dark condition was studied and is presented in Figure 17.

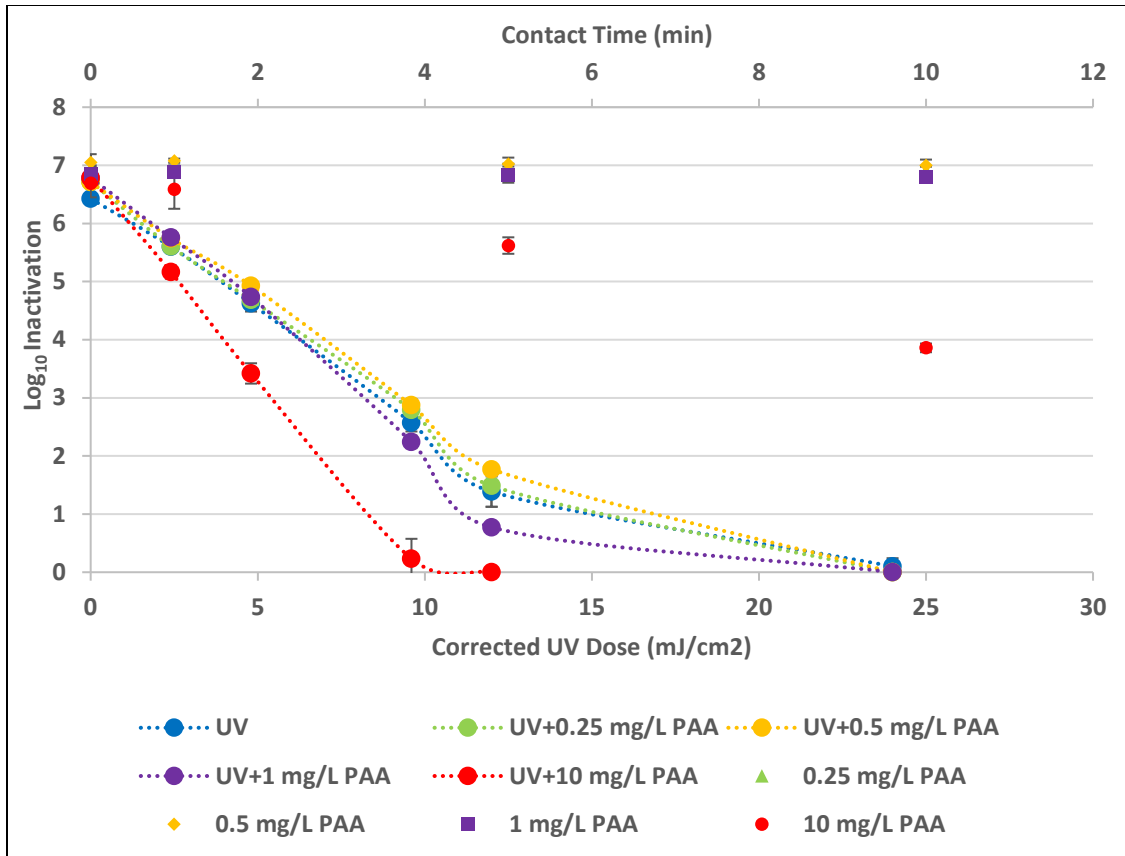

Figure 17. Bench-scale Inactivation of P22 by UV or PAA-UV

According to Figures 16 and 17, P22 showed higher resistance than *E. coli* to PAA-UV advanced oxidation with no significant increase in inactivation until 1 mg/L PAA was implemented to the reactor simultaneously to UV by which 18% increase in P22 inactivation was observed compared to UV inactivation at dose of 9.6 mJ/cm<sup>2</sup>. Furthermore, at the same UV dose, applying 10 mg/L PAA resulted in a drastic jump in P22 inactivation from 3.9 to more than 6.6 logs which means a minimum of 69% inactivation increase.

Parameters of the water in which all bench-scale PAA-UV experiments were conducted is summarized in the table below as average of triplicate measurements.

Table 3. Water Quality Parameters for bench-scale PAA-UV AOP experiments

PAA Concentration (mg/L)	Turbidity (NTU)	UVT (%)	pH before injecting PAA	pH after injecting PAA
0	1.0	83.9	7.50	7.5
0.25	1.1	83.8	7.50	7.48
0.5	1.0	83.9	7.50	7.48
1	1.0	83.9	7.50	7.47
10	1.2	83.9	7.50	7.38

#### 4.2 Pilot-scale Inactivation Experiments

Pilot-scale experiments were performed separately using Photo-Cat device and NeoTech D222 device for TiO<sub>2</sub>-UV and PAA-UV AOPs, respectively. The results are presented in the next two subsections.

##### 4.2.1 Inactivation of P22, Using Purifics Photo-Cat by UV or TiO<sub>2</sub>-UV

Photocatalytic Log<sub>10</sub> inactivation of P22 by TiO<sub>2</sub>-UV using Photo-Cat is presented in Figure 17. Additional experiments for inactivation of P22 by UV light and using Purifics Photo-Cat were also performed to generate a baseline in order to be able to compare photocatalytic and UV inactivation of P22. The possible effect of TiO<sub>2</sub> nanoparticles on P22 degradation had been studied in the bench-scale experiments and therefore has not been repeated here for pilot-scale experiments.



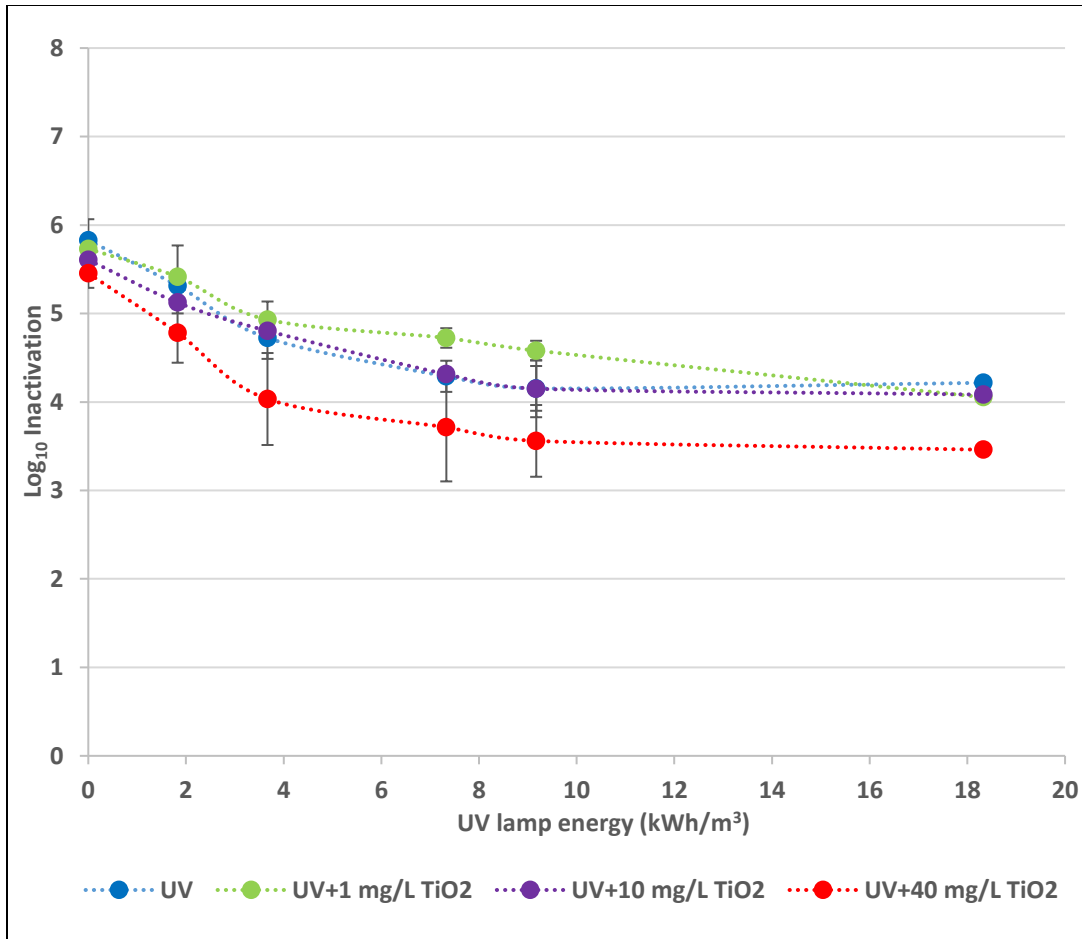

Figure 18. Pilot-scale Inactivation of P22 by UV or TiO<sub>2</sub>-UV using Photo-Cat

As figure 17 illustrates, photocatalytic inactivation of P22 using Photo-Cat increased as TiO<sub>2</sub> dose increased which is the opposite trend observed using the collimated beam apparatus. This is concurrent with a similar study done using the same UV units but different viruses (Gerrity et al. 2008). Interestingly, when 1 mg/L TiO<sub>2</sub> was applied to the influent, P22 inactivation achieved was lower compared to UV inactivation. One hypothesis can be that 1 mg/L of TiO<sub>2</sub> added was high enough to block a portion of direct UV exposure of P22 cells but also low enough not to produce as much ROS to overcome UV blockage effect on overall inactivation. As higher doses of TiO<sub>2</sub> was applied to the influent, P22 inactivation started to increase using Photo-Cat and

eventually 25% increase in P22 inactivation was achieved with the highest TiO<sub>2</sub> dose used (40 mg/L) compared to UV. Table 4 provides certain water quality parameters measured for TiO<sub>2</sub>-UV AOP experiments using the Photo-Cat.

Table 4. Water Quality Parameters for Pilot-scale TiO<sub>2</sub>-UV AOP Experiments

TiO <sub>2</sub> Concentration (mg/L)	TiO <sub>2</sub> particles size in RO water by DLS (nm)	Influent Turbidity (NTU)	Effluent Turbidity (NTU)	Influent UVT (%)	Effluent pH
0	-	0.01	0.01	95.46	8.0
1	793.6	4.80	0.07	99.64	7.6
10	575.8	46.12	0.07	99.57	7.3
40	490.8	155.9	0.07	99.52	7.4

Higher inactivation synergy using Photo-Cat for the same concentrations of TiO<sub>2</sub> compared to that of collimate beam apparatus can possibly be due to significant smaller mean size of TiO<sub>2</sub> particles in the RO water which was used to run Photo-Cat experiments. Furthermore, average UVT in the RO water was much higher than the average UVT in the PBS, potentially resulting in illumination of more TiO<sub>2</sub> particles and consequently producing more hydroxyl radicals in the RO water as opposed to PBS.

#### 4.2.2 Inactivation of *E. coli* and P22, Using D222 UV Device by UV or PAA-UV

As opposed to the bench-scale PAA-UV photocatalytic experiments, the influent for pilot-scale PAA-UV AOP experiments was spiked with both P22 and *E. coli* and

samples were assayed for both of microorganisms. Log<sub>10</sub> inactivation of P22 and *E. coli* by PAA-UV or UV using D222 device from NeoTech Aqua Solutions is plotted in Figure 18 versus UV and PAA dose. The effect of PAA could not be examined due to the configuration of the setup. However, since the contact time between PAA and the influent was only several seconds before UV exposure and zero direct inactivation by PAA was demonstrated in bench-scale experiments for PAA doses applied on either P22 or *E. coli*, it was assumed that PAA by itself does not contribute to microbial inactivation in pilot-scale PAA-UV experiments. Additionally, certain water quality parameters of both influent and effluent were measured and are reported in table 5.

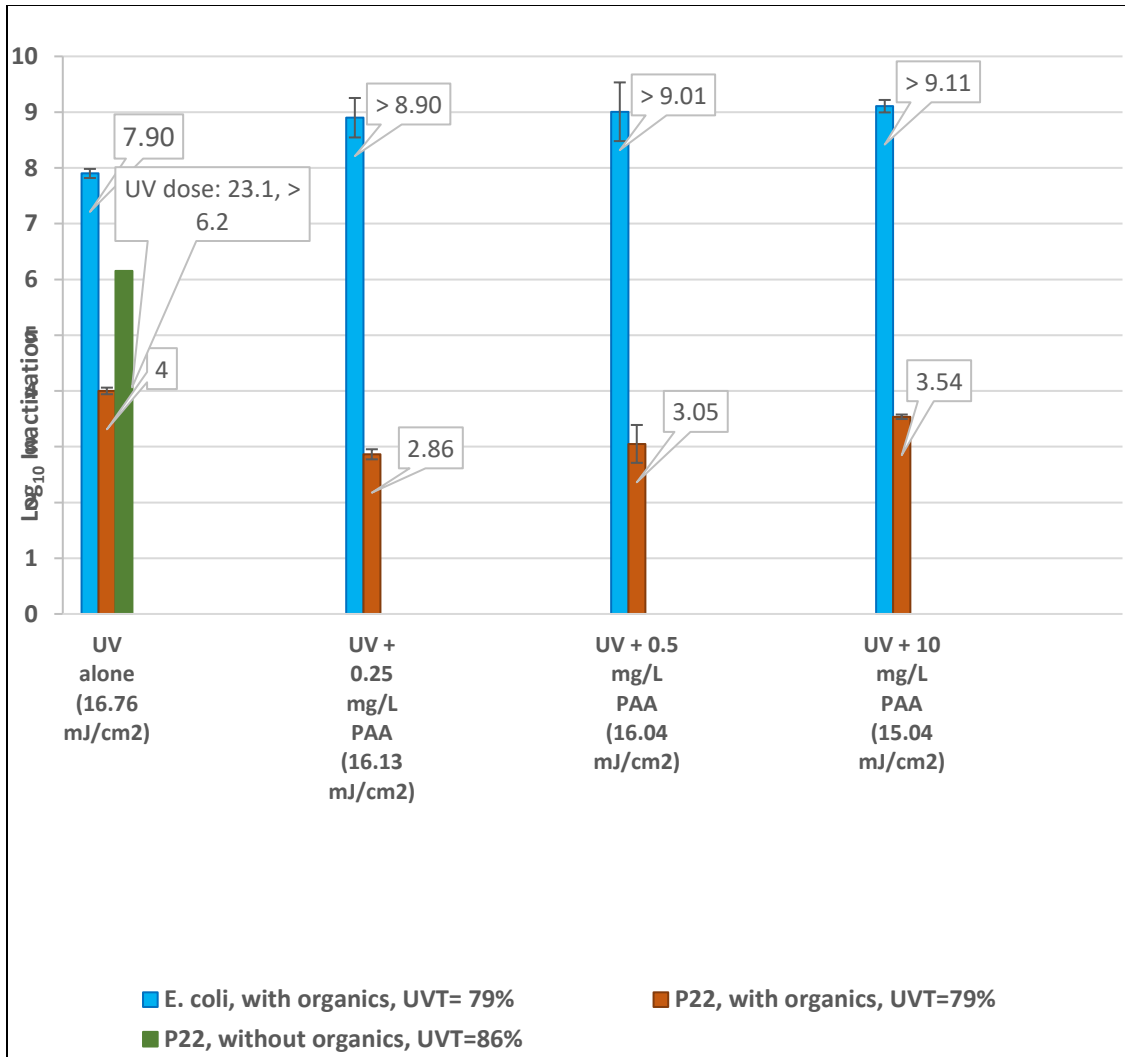

Figure 19. Pilot-scale Inactivation of *E. coli* and P22 by UV or PAA-UV using D222 device

D222 UV device was capable of inactivating 7.9 and 4 logs of *E. coli* and P22 respectively at UV dose of 16.8 mJ/cm<sup>2</sup> from the influent with UVT= 78.8% and dissolved organic carbon concentration of 36.5 mg/L. *E. coli* inactivation was improved by at least 11%, from 7.9 to more than 8.9, after dosing 0.25 mg/L PAA upstream of the UV. All photocatalytic inactivation experiments on *E. coli* by PAA-UV using D222 UV device achieved complete inactivation and no colony was detected in the effluent.

Interestingly, P22 inactivation dropped from 4.00 to 2.86 logs after applying 0.25 mg/L PAA upstream of UV. However, photocatalytic inactivation of P22 increased with higher PAA doses reaching 3.05 and 3.54 logs by applying UV(16.04 mJ/cm<sup>2</sup>)+PAA(0.5) and UV(15.04 mJ/cm<sup>2</sup>)+PAA(10), respectively. Nevertheless, the highest inactivation for P22 was achieved by UV without applying PAA.

This higher resistance of P22 to PAA-UV advanced oxidation compared to *E. coli* is concurrent with some studies (Koivunen, Heinonen-Tanski 2005a, Koivunen, Heinonen-Tanski 2005b, Luukkonen et al. 2014).

Certain water quality parameters of the samples were measured and are reported in Table 5 and 6.

Table 5. Influent Quality Parameters for Pilot-scale PAA-UV AOP Experiments

Applied PAA concentration (mg/L)	Influent Turbidity (NTU)	Influent UVT (%)	Influent DOC concentration (mg/L)	Influent pH	PAA concentration measured in influent (mg/L)
0	2.15	78.78	36.54	7.67	-
0.25	2.14	78.71	36.59	7.66	0.20
0.5	2.13	79.25	36.37	7.65	0.44
10	2.29	80.05	36.22	7.66	Not Measured

Table 6. Effluent Quality Parameters for Pilot-scale PAA-UV AOP Experiments

Applied PAA concentration (mg/L)	Effluent Turbidity (NTU)	Effluent UVT (%)	Effluent DOC concentration (mg/L)	Effluent pH	Effluent PAA residual concentration (mg/L)
0	2.21	77.75	35.03	7.66	-
0.25	2.19	79.50	37.85	7.64	0.02
0.5	1.92	79.62	37.95	7.63	0.016
10	2.51	74.89	45.78	7.52	Not Measured

In all experiments conducted using D222 UV device, water quality parameters did not change significantly during the experiment. Table 6 and 7 demonstrate minimal turbidity, pH, organic concentration, and UVT change even when 10 mg/L PAA was applied upstream of the UV lamp.

Not only did not PAA-UV AOP decrease dissolved organic carbon concentration, it also increased dissolved organic carbon concentration by 9.5 mg/L when 10 mg/L PAA was dosed upstream of D222 UV device probably due to decomposition of PAA to acetic acid and oxygen (Luukkonen et al. 2014, US EPA. 1999).

## CHAPTER 5

### CONCLUSION

The results provide new insight on the effectiveness and applicability of adding AOP to UV for microbial inactivation in water. PAA-UV AOP can potentially enhance existing UV disinfection systems with minimal chemical addition, and a simple retrofit to existing UV units. In summary, the following conclusions can be drawn from this study:

- Neither PAA nor TiO<sub>2</sub> showed primary disinfectant capabilities at tested doses with applied exposure times except for 10 mg/L PAA.
- P22 inactivation curve using Photo-Cat reached a plateau and the processes did not inactivate P22 more than 2 logs.
- Photo-Cat showed higher inactivation synergy with TiO<sub>2</sub>, compared to collimated beam apparatus.
- Higher concentrations of TiO<sub>2</sub> particles in the reactor resulted in aggregation and elevated turbidity, and consequently lower inactivation for both *E. coli* and P22 in the collimated beam apparatus.
- D222 UV device from NeoTech Aqua Solutions, Inc. outperformed conventional UV devices in terms of microbial inactivation most likely due to its inner reflective coating. More than 6 logs of P22 was inactivated from water with UVT ~86%.
- PAA-UV AOP appears to bring about high inactivation synergy for *E. coli* from water, regardless of water quality. However, inactivation synergy on P22 by PAA-UV AOP appears to be affected by water quality.

- No synergistic inactivation was observed for P22 using D222 UV reactor device with PAA. Minimal pH changes were observed in effluent from PAA-UV AOP experiments.
- D222 UV device was capable of reducing DOC, however, DOC were increased by varying degrees in PAA-UV AOPs experiments using the same device.



## REFERENCES

- Ultraviolet Disinfection Guidance Manual for the Final Long Term 2 Enhanced Surface Water Treatment Rule* - ZyPDF.cgi. Available:  
<https://nepis.epa.gov/Exe/ZyPDF.cgi?Dockkey=600006T3.txt> [2017, 7/2/2017].
- Abbaszadegan, M., Mayer, B.K., Ryu, H. & Nwachuku, N. 2007, "Efficacy of removal of CCL viruses under enhanced coagulation conditions", *Environmental science & technology*, vol. 41, no. 3, pp. 971-977.
- Abeledo-Lameiro, M.J., Ares-Mazás, E. & Gómez-Couso, H. 2016, "Evaluation of solar photocatalysis using TiO<sub>2</sub> slurry in the inactivation of *Cryptosporidium parvum* oocysts in water", *Journal of Photochemistry and Photobiology B: Biology*, vol. 163, pp. 92-99.
- Andreozzi, R., Caprio, V., Insola, A. & Marotta, R. 1999, "Advanced oxidation processes (AOP) for water purification and recovery", *Catalysis today*, vol. 53, no. 1, pp. 51-59.
- Ashikaga, T., Wada, M., Kobayashi, H., Mori, M., Katsumura, Y., Fukui, H., Kato, S., Yamaguchi, M. & Takamatsu, T. 2000, "Effect of the photocatalytic activity of TiO<sub>2</sub> on plasmid DNA", *Mutation Research/Genetic Toxicology and Environmental Mutagenesis*, vol. 466, no. 1, pp. 1-7.
- Bacteriophages, M.A. 1959, "Interscience Publishers", *New York*, , pp. 444-485.
- Baldry, M. & French, M. 1989, "Activity of peracetic acid against sewage indicator organisms", *Water science and technology*, vol. 21, no. 12, pp. 1747-1749.
- Beber de Souza, J., Queiroz Valdez, F., Jeranoski, R.F., Vidal, Carlos Magno de Sousa & Cavallini, G.S. 2015, "Water and wastewater disinfection with peracetic acid and uv radiation and using advanced oxidative process PAA/UV", *International Journal of Photoenergy*, vol. 2015.
- Benabbou, A., Derriche, Z., Felix, C., Lejeune, P. & Guillard, C. 2007, "Photocatalytic inactivation of *Escherichia coli*: Effect of concentration of TiO<sub>2</sub> and microorganism, nature, and intensity of UV irradiation", *Applied Catalysis B: Environmental*, vol. 76, no. 3, pp. 257-263.
- Block, P., Reimers, R. & Xu, Y. 2015, "Use of Peracetic Acid as a Wastewater Disinfectant to Eliminate the Formation of Chlorinated Disinfection By-products and Inhibit the Activity of Endocrine Disrupting Compounds", *Proceedings of the Water Environment Federation*, vol. 2015, no. 9, pp. 528-535.

- Bolton, J.R. & Linden, K.G. 2003, "Standardization of methods for fluence (UV dose) determination in bench-scale UV experiments", *Journal of Environmental Engineering*, vol. 129, no. 3, pp. 209-215.
- Boorman, G.A. 1999, "Drinking water disinfection byproducts: review and approach to toxicity evaluation", *Environmental health perspectives*, vol. 107 Suppl 1, pp. 207-217.
- Booth, R. & Lester, J. 1995, "The potential formation of halogenated by-products during peracetic acid treatment of final sewage effluent", *Water research*, vol. 29, no. 7, pp. 1793-1801.
- Caretti, C. & Lubello, C. 2003a, "Wastewater disinfection with PAA and UV combined treatment: a pilot plant study", *Water research*, vol. 37, no. 10, pp. 2365-2371.
- Caretti, C. & Lubello, C. 2003b, "Wastewater disinfection with PAA and UV combined treatment: a pilot plant study", *Water research*, vol. 37, no. 10, pp. 2365-2371.
- Chai, Y., Lee, J. & Kim, B. 2000, "Photocatalytic disinfection of E. coli in a suspended TiO<sub>2</sub>/UV reactor", *Korean Journal of Chemical Engineering*, vol. 17, no. 6, pp. 633-637.
- Chang, J.C., Ossoff, S.F., Lobe, D.C., Dorfman, M.H., Dumais, C.M., Qualls, R.G. & Johnson, J.D. 1985, "UV inactivation of pathogenic and indicator microorganisms", *Applied and Environmental Microbiology*, vol. 49, no. 6, pp. 1361-1365.
- Cho, M., Chung, H., Choi, W. & Yoon, J. 2004, "Linear correlation between inactivation of E. coli and OH radical concentration in TiO<sub>2</sub> photocatalytic disinfection", *Water research*, vol. 38, no. 4, pp. 1069-1077.
- Cho, M., Chung, H., Choi, W. & Yoon, J. 2005, "Different inactivation behaviors of MS-2 phage and Escherichia coli in TiO<sub>2</sub> photocatalytic disinfection", *Applied and Environmental Microbiology*, vol. 71, no. 1, pp. 270-275.
- Chong, M.N., Jin, B., Chow, C.W. & Saint, C. 2010, "Recent developments in photocatalytic water treatment technology: a review", *Water research*, vol. 44, no. 10, pp. 2997-3027.
- Cingolani, G., Moore, S.D., Prevelige, P.E. & Johnson, J.E. 2002, "Preliminary crystallographic analysis of the bacteriophage P22 portal protein", *Journal of structural biology*, vol. 139, no. 1, pp. 46-54.
- Clancy, J.L., Bukhari, Z., Hargy, T.M. & Bolton, J.R. 2000, "Using UV to inactivate *Cryptosporidium*", *American Water Works Association Journal*, vol. 92, no. 9, pp. 97.

- Comninellis, C., Kapalka, A., Malato, S., Parsons, S.A., Poullos, I. & Mantzavinos, D. 2008, "Advanced oxidation processes for water treatment: advances and trends for R&D", *Journal of Chemical Technology and Biotechnology*, vol. 83, no. 6, pp. 769-776.
- Craik, S.A., Weldon, D., Finch, G.R., Bolton, J.R. & Belosevic, M. 2001, "Inactivation of *Cryptosporidium parvum* oocysts using medium-and low-pressure ultraviolet radiation", *Water research*, vol. 35, no. 6, pp. 1387-1398.
- Crebelli, R., Conti, L., Monarca, S., Feretti, D., Zerbini, I., Zani, C., Veschetti, E., Cutilli, D. & Ottaviani, M. 2005, "Genotoxicity of the disinfection by-products resulting from peracetic acid-or hypochlorite-disinfected sewage wastewater", *Water research*, vol. 39, no. 6, pp. 1105-1113.
- Cutler, D. & Miller, G. 2005, "The role of public health improvements in health advances: the twentieth-century United States", *Demography*, vol. 42, no. 1, pp. 1-22.
- Day, R.S. 1993, "Deoxyguanosine reverses inhibition by hydroxyurea of repair of UV-irradiated adenovirus 5", *Mutation Research/DNA Repair*, vol. 293, no. 3, pp. 215-223.
- Deng, Y. & Zhao, R. 2015, "Advanced oxidation processes (AOPs) in wastewater treatment", *Current Pollution Reports*, vol. 1, no. 3, pp. 167-176.
- Eggin, B.R., Palmer, F.L. & Byrne, J.A. 1997, "Photocatalytic treatment of humic substances in drinking water", *Water research*, vol. 31, no. 5, pp. 1223-1226.
- Fujishima, A., Rao, T.N. & Tryk, D.A. 2000, "Titanium dioxide photocatalysis", *Journal of Photochemistry and Photobiology C: Photochemistry Reviews*, vol. 1, no. 1, pp. 1-21.
- Fujishima, A., Zhang, X. & Tryk, D.A. 2008, "TiO<sub>2</sub> photocatalysis and related surface phenomena", *Surface Science Reports*, vol. 63, no. 12, pp. 515-582.
- Gaya, U.I. & Abdullah, A.H. 2008, "Heterogeneous photocatalytic degradation of organic contaminants over titanium dioxide: a review of fundamentals, progress and problems", *Journal of Photochemistry and Photobiology C: Photochemistry Reviews*, vol. 9, no. 1, pp. 1-12.
- Gerrity, D., Mayer, B., Ryu, H., Crittenden, J. & Abbaszadegan, M. 2009, "A comparison of pilot-scale photocatalysis and enhanced coagulation for disinfection byproduct mitigation", *Water research*, vol. 43, no. 6, pp. 1597-1610.

- Gerrity, D., Ryu, H., Crittenden, J. & Abbaszadegan, M. 2008, "Photocatalytic inactivation of viruses using titanium dioxide nanoparticles and low-pressure UV light", *Journal of Environmental Science and Health Part A*, vol. 43, no. 11, pp. 1261-1270.
- Guimarães, J. & Barretto, A. 2003, "Photocatalytic inactivation of *Clostridium perfringens* and coliphages in water", *Brazilian Journal of Chemical Engineering*, vol. 20, no. 4, pp. 403-411.
- Guo, B., Pasco, E.V., Xagorarakis, I. & Tarabara, V.V. 2015, "Virus removal and inactivation in a hybrid microfiltration–UV process with a photocatalytic membrane", *Separation and Purification Technology*, vol. 149, pp. 245-254.
- Haag, W.R. & Yao, C.D. 1992, "Rate constants for reaction of hydroxyl radicals with several drinking water contaminants", *Environmental science & technology*, vol. 26, no. 5, pp. 1005-1013.
- Hijnen, W., Beerendonk, E. & Medema, G.J. 2006, "Inactivation credit of UV radiation for viruses, bacteria and protozoan (oo) cysts in water: a review", *Water research*, vol. 40, no. 1, pp. 3-22.
- Hirakawa, T. & Nosaka, Y. 2002, "Properties of O<sub>2</sub>•- and OH• formed in TiO<sub>2</sub> aqueous suspensions by photocatalytic reaction and the influence of H<sub>2</sub>O<sub>2</sub> and some ions", *Langmuir*, vol. 18, no. 8, pp. 3247-3254.
- Hoff, J.C., Rice, E.W. & Schaefer, F. 1984, "Disinfection and the control of waterborne giardiasis", *Proceedings 1984 Speciality Conference on Environmental Engineering*, pp. 40.
- Howe, K.J., Hand, D.W., Crittenden, J.C., Trussell, R.R. & Tchobanoglous, G. 2012, "Disinfection with Free and Combined Chlorine" in *PRINCIPLES OF WATER TREATMENT*, 3rd edn, John Wiley & Sons, Inc, Hoboken, New Jersey, pp. 532.
- Huang, X., Leal, M. & Li, Q. 2008, "Degradation of natural organic matter by TiO<sub>2</sub> photocatalytic oxidation and its effect on fouling of low-pressure membranes", *Water research*, vol. 42, no. 4, pp. 1142-1150.
- Ireland, J.C., Klostermann, P., Rice, E.W. & Clark, R.M. 1993, "Inactivation of *Escherichia coli* by titanium dioxide photocatalytic oxidation", *Applied and Environmental Microbiology*, vol. 59, no. 5, pp. 1668-1670.
- Ishibashi, K., Fujishima, A., Watanabe, T. & Hashimoto, K. 2000, "Detection of active oxidative species in TiO<sub>2</sub> photocatalysis using the fluorescence technique", *Electrochemistry Communications*, vol. 2, no. 3, pp. 207-210.

- Jiang, S.C. 2006, "Human adenoviruses in water: occurrence and health implications: a critical review", *Environmental science & technology*, vol. 40, no. 23, pp. 7132-7140.
- Kim, S., Ghafoor, K., Lee, J., Feng, M., Hong, J., Lee, D. & Park, J. 2013, "Bacterial inactivation in water, DNA strand breaking, and membrane damage induced by ultraviolet-assisted titanium dioxide photocatalysis", *Water research*, vol. 47, no. 13, pp. 4403-4411.
- Kim, T.Y., Lee, Y., Park, K., Kim, S.J. & Cho, S.Y. 2005, "A study of photocatalysis of TiO<sub>2</sub> coated onto chitosan beads and activated carbon", *Research on Chemical Intermediates*, vol. 31, no. 4, pp. 343-358.
- Kitis, M. 2004, "Disinfection of wastewater with peracetic acid: a review", *Environment international*, vol. 30, no. 1, pp. 47-55.
- Kluge, M., Fleck, J., Soliman, M., Luz, R., Fabres, R., Comerlato, J., Silva, J., Staggemeier, R., Vecchia, A. & Capalunga, R. 2014, "Human adenovirus (HAdV), human enterovirus (hEV), and genogroup A rotavirus (GARV) in tap water in southern Brazil", *Journal of water and health*, vol. 12, no. 3, pp. 526-532.
- Koivunen, J. & Heinonen-Tanski, H. 2005a, "Peracetic acid (PAA) disinfection of primary, secondary and tertiary treated municipal wastewaters", *Water research*, vol. 39, no. 18, pp. 4445-4453.
- Koivunen, J. & Heinonen-Tanski, H. 2005b, "Inactivation of enteric microorganisms with chemical disinfectants, UV irradiation and combined chemical/UV treatments", *Water research*, vol. 39, no. 8, pp. 1519-1526.
- Korich, D.G., Mead, J.R., Madore, M.S., Sinclair, N.A. & Sterling, C.R. 1990, "Effects of ozone, chlorine dioxide, chlorine, and monochloramine on *Cryptosporidium parvum* oocyst viability", *Applied and Environmental Microbiology*, vol. 56, no. 5, pp. 1423-1428.
- Lamsal, R., Walsh, M.E. & Gagnon, G.A. 2011, "Comparison of advanced oxidation processes for the removal of natural organic matter", *Water research*, vol. 45, no. 10, pp. 3263-3269.
- LeChevallier, M.W., Cawthon, C.D. & Lee, R.G. 1988, "Factors promoting survival of bacteria in chlorinated water supplies", *Applied and Environmental Microbiology*, vol. 54, no. 3, pp. 649-654.
- Lee, J.H., Kang, M., Choung, S., Ogino, K., Miyata, S., Kim, M., Park, J. & Kim, J. 2004, "The preparation of TiO<sub>2</sub> nanometer photocatalyst film by a hydrothermal

- method and its sterilization performance for *Giardia lamblia*", *Water research*, vol. 38, no. 3, pp. 713-719.
- Lee, J.E. & Ko, G. 2013, "Norovirus and MS2 inactivation kinetics of UV-A and UV-B with and without TiO<sub>2</sub>", *Water research*, vol. 47, no. 15, pp. 5607-5613.
- Liberti, L. & Notarnicola, M. 1999, "Advanced treatment and disinfection for municipal wastewater reuse in agriculture", *Water Science and Technology*, vol. 40, no. 4-5, pp. 235-245.
- Liga, M.V., Bryant, E.L., Colvin, V.L. & Li, Q. 2011, "Virus inactivation by silver doped titanium dioxide nanoparticles for drinking water treatment", *Water research*, vol. 45, no. 2, pp. 535-544.
- Linden, K.G., Thurston, J., Schaefer, R. & Malley, J.P., Jr 2007, "Enhanced UV inactivation of adenoviruses under polychromatic UV lamps", *Applied and Environmental Microbiology*, vol. 73, no. 23, pp. 7571-7574.
- Liu, S., Lim, M., Fabris, R., Chow, C., Chiang, K., Drikas, M. & Amal, R. 2008a, "Removal of humic acid using TiO<sub>2</sub> photocatalytic process—fractionation and molecular weight characterisation studies", *Chemosphere*, vol. 72, no. 2, pp. 263-271.
- Liu, S., Lim, M., Fabris, R., Chow, C., Drikas, M. & Amal, R. 2010, "Comparison of photocatalytic degradation of natural organic matter in two Australian surface waters using multiple analytical techniques", *Organic Geochemistry*, vol. 41, no. 2, pp. 124-129.
- Liu, S., Lim, M., Fabris, R., Chow, C., Drikas, M. & Amal, R. 2008b, "TiO<sub>2</sub> photocatalysis of natural organic matter in surface water: impact on trihalomethane and haloacetic acid formation potential", *Environmental science & technology*, vol. 42, no. 16, pp. 6218-6223.
- Liu, W., Cheung, L., Yang, X. & Shang, C. 2006, "THM, HAA and CNCl formation from UV irradiation and chlor (am) ination of selected organic waters", *Water research*, vol. 40, no. 10, pp. 2033-2043.
- Long, T.C., Saleh, N., Tilton, R.D., Lowry, G.V. & Veronesi, B. 2006, "Titanium dioxide (P25) produces reactive oxygen species in immortalized brain microglia (BV2): implications for nanoparticle neurotoxicity", *Environmental science & technology*, vol. 40, no. 14, pp. 4346-4352.
- Lonnen, J., Kilvington, S., Kehoe, S., Al-Touati, F. & McGuigan, K. 2005, "Solar and photocatalytic disinfection of protozoan, fungal and bacterial microbes in drinking water", *Water research*, vol. 39, no. 5, pp. 877-883.

- Lubello, C., Caretti, C. & Gori, R. 2002, "Comparison between PAA/UV and H<sub>2</sub>O<sub>2</sub>/UV disinfection for wastewater reuse", *Water Science and technology: water supply*, vol. 2, no. 1, pp. 205-212.
- Luukkonen, T., Teeriniemi, J., Prokkola, H., Rämö, J. & Lassi, U. 2014, "Chemical aspects of peracetic acid based wastewater disinfection", *Water SA*, vol. 40, no. 1, pp. 73-80.
- Madrid, E. & Oleszkiewicz, J. 2005, "Photo-activated Peracetic Acid Enhances UV Disinfection of Wastewater Effluents", *Proceedings of the Water Environment Federation*, vol. 2005, no. 7, pp. 7706-7716.
- Matilainen, A. & Sillanpää, M. 2010, "Removal of natural organic matter from drinking water by advanced oxidation processes", *Chemosphere*, vol. 80, no. 4, pp. 351-365.
- Matilainen, A., Vepsäläinen, M. & Sillanpää, M. 2010, "Natural organic matter removal by coagulation during drinking water treatment: a review", *Advances in Colloid and Interface Science*, vol. 159, no. 2, pp. 189-197.
- Mayer, B.K., Daugherty, E. & Abbaszadegan, M. 2014, "Disinfection byproduct formation resulting from settled, filtered, and finished water treated by titanium dioxide photocatalysis", *Chemosphere*, vol. 117, pp. 72-78.
- McGuire, M.J. 2006, "Eight revolutions in the history of US drinking water disinfection", *American Water Works Association Journal*, vol. 98, no. 3, pp. 123.
- Nakano, R., Ishiguro, H., Yao, Y., Kajioka, J., Fujishima, A., Sunada, K., Minoshima, M., Hashimoto, K. & Kubota, Y. 2012, "Photocatalytic inactivation of influenza virus by titanium dioxide thin film", *Photochemical & Photobiological Sciences*, vol. 11, no. 8, pp. 1293-1298.
- Navalon, S., Alvaro, M., Garcia, H., Escrig, D. & Costa, V. 2009, "Photocatalytic water disinfection of *Cryptosporidium parvum* and *Giardia lamblia* using a fibrous ceramic TiO<sub>2</sub> photocatalyst", *Water Science and Technology*, vol. 59, no. 4, pp. 639-645.
- Nieuwenhuijsen, M.J., Toledano, M.B., Eaton, N.E., Fawell, J. & Elliott, P. 2000, "Chlorination disinfection byproducts in water and their association with adverse reproductive outcomes: a review", *Occupational and environmental medicine*, vol. 57, no. 2, pp. 73-85.
- Nwachuku, N., Gerba, C.P., Oswald, A. & Mashadi, F.D. 2005, "Comparative inactivation of adenovirus serotypes by UV light disinfection", *Applied and Environmental Microbiology*, vol. 71, no. 9, pp. 5633-5636.

- Parsons, S. 2004, *Advanced oxidation processes for water and wastewater treatment*, IWA publishing.
- Peng, L., Wenli, D., Qisui, W. & Xi, L. 2010, "The envelope damage of Tetrahymena in the presence of TiO<sub>2</sub> combined with UV light", *Photochemistry and photobiology*, vol. 86, no. 3, pp. 633-638.
- Rajala-Mustonen, R., Toivola, P. & Heinonen-Tanski, H. 1997, "Effects of peracetic acid and UV irradiation on the inactivation of coliphages in wastewater", *Water science and technology*, vol. 35, no. 11-12, pp. 237-241.
- Reckhow, D.A., Linden, K.G., Kim, J., Shemer, H. & Makdissy, G. 2010, "Effect of UV treatment on DBP formation", *American Water Works Association Journal*, vol. 102, no. 6, pp. 100.
- Richardson, S.D. 2003, "Disinfection by-products and other emerging contaminants in drinking water", *TrAC Trends in Analytical Chemistry*, vol. 22, no. 10, pp. 666-684.
- Richardson, S.D., Plewa, M.J., Wagner, E.D., Schoeny, R. & DeMarini, D.M. 2007, "Occurrence, genotoxicity, and carcinogenicity of regulated and emerging disinfection by-products in drinking water: a review and roadmap for research", *Mutation Research/Reviews in Mutation Research*, vol. 636, no. 1, pp. 178-242.
- Rincón, A. & Pulgarin, C. 2003, "Photocatalytical inactivation of E. coli: effect of (continuous–intermittent) light intensity and of (suspended–fixed) TiO<sub>2</sub> concentration", *Applied Catalysis B: Environmental*, vol. 44, no. 3, pp. 263-284.
- Rokhina, E.V., Makarova, K., Golovina, E.A., Van As, H. & Virkutyte, J. 2010, "Free radical reaction pathway, thermochemistry of peracetic acid homolysis, and its application for phenol degradation: spectroscopic study and quantum chemistry calculations", *Environmental science & technology*, vol. 44, no. 17, pp. 6815-6821.
- Rook, J.J. 1974, "Formation of haloforms during chlorination of natural waters", *Water Treat.Exam.*, vol. 23, pp. 234-243.
- Ryu, H., Gerrity, D., Crittenden, J.C. & Abbaszadegan, M. 2008, "Photocatalytic inactivation of *Cryptosporidium parvum* with TiO<sub>2</sub> and low-pressure ultraviolet irradiation", *Water research*, vol. 42, no. 6, pp. 1523-1530.
- Sharma, S., Mukhopadhyay, M. & Murthy, Z. 2012, "Rate parameter estimation for 4-chlorophenol degradation by UV and organic oxidants", *Journal of Industrial and Engineering Chemistry*, vol. 18, no. 1, pp. 249-254.



- Sharma, S., Mukhopadhyay, M. & Murthy, Z. 2010, "Degradation of 4-chlorophenol in wastewater by organic oxidants", *Industrial & Engineering Chemistry Research*, vol. 49, no. 7, pp. 3094-3098.
- Shin, G.A., Linden, K.G., Arrowood, M.J. & Sobsey, M.D. 2001, "Low-pressure UV inactivation and DNA repair potential of *Cryptosporidium parvum* oocysts", *Applied and Environmental Microbiology*, vol. 67, no. 7, pp. 3029-3032.
- Sinclair, R., Jones, E. & Gerba, C. 2009, "Viruses in recreational water-borne disease outbreaks: A review", *Journal of applied microbiology*, vol. 107, no. 6, pp. 1769-1780.
- Sjogren, J.C. & Sierka, R.A. 1994, "Inactivation of Phage MS2 by Iron-Aided Titanium Dioxide Photocatalysis", *Applied and Environmental Microbiology*, vol. 60, no. 1, pp. 344-347.
- Sökmen, M., Değerli, S. & Aslan, A. 2008, "Photocatalytic disinfection of *Giardia intestinalis* and *Acanthamoeba castellanii* cysts in water", *Experimental parasitology*, vol. 119, no. 1, pp. 44-48.
- Stancl, H.O., Hristovski, K. & Westerhoff, P. 2015, "Hexavalent chromium removal using UV-TiO<sub>2</sub>/ceramic membrane reactor", *Environmental Engineering Science*, vol. 32, no. 8, pp. 676-683.
- Sunnotel, O., Verdoold, R., Dunlop, P., Snelling, W., Lowery, C., Dooley, J., Moore, J. & Byrne, J. 2010, "Photocatalytic inactivation of *Cryptosporidium parvum* on nanostructured titanium dioxide films", *Journal of water and health*, vol. 8, no. 1, pp. 83-91.
- Thiruvengkatachari, R., Vigneswaran, S. & Moon, I.S. 2008, "A review on UV/TiO<sub>2</sub> photocatalytic oxidation process (Journal Review)", *Korean Journal of Chemical Engineering*, vol. 25, no. 1, pp. 64-72.
- Thurston-Enriquez, J.A., Haas, C.N., Jacangelo, J. & Gerba, C.P. 2005a, "Inactivation of enteric adenovirus and feline calicivirus by ozone", *Water research*, vol. 39, no. 15, pp. 3650-3656.
- Thurston-Enriquez, J.A., Haas, C.N., Jacangelo, J. & Gerba, C.P. 2005b, "Inactivation of enteric adenovirus and feline calicivirus by chlorine dioxide", *Applied and Environmental Microbiology*, vol. 71, no. 6, pp. 3100-3105.
- Thurston-Enriquez, J.A., Haas, C.N., Jacangelo, J. & Gerba, C.P. 2003a, "Chlorine inactivation of adenovirus type 40 and feline calicivirus", *Applied and Environmental Microbiology*, vol. 69, no. 7, pp. 3979-3985.

- Thurston-Enriquez, J.A., Haas, C.N., Jacangelo, J., Riley, K. & Gerba, C.P. 2003b, "Inactivation of feline calicivirus and adenovirus type 40 by UV radiation", *Applied and Environmental Microbiology*, vol. 69, no. 1, pp. 577-582.
- US EPA. 1999, *Combined Sewer Overflow Technology Fact Sheet Alternative Disinfection Methods*, United States Environmental Protection Agency, Washington, D.C.
- USEPA, A.D. 1999, "Oxidants Guidance Manual", *US Environmental Protection Agency, Office of Water, Washington, DC*, .
- Verheyen, J., Timmen-Wego, M., Laudien, R., Boussaad, I., Sen, S., Koc, A., Uesbeck, A., Mazou, F. & Pfister, H. 2009, "Detection of adenoviruses and rotaviruses in drinking water sources used in rural areas of Benin, West Africa", *Applied and Environmental Microbiology*, vol. 75, no. 9, pp. 2798-2801.
- Veschetti, E., Cutilli, D., Bonadonna, L., Briancesco, R., Martini, C., Cecchini, G., Anastasi, P. & Ottaviani, M. 2003, "Pilot-plant comparative study of peracetic acid and sodium hypochlorite wastewater disinfection", *Water research*, vol. 37, no. 1, pp. 78-94.
- World Health Organization (WHO) and the United Nations Children's Fund (UNICEF) 2017, *Progress on drinking water, sanitation and hygiene: 2017 update and SDG baselines*.
- Zhang, B., Li-Xia, Z. & Jin-Ming, L. 2008, "Study on superoxide and hydroxyl radicals generated in indirect electrochemical oxidation by chemiluminescence and UV-Visible spectra", *Journal of Environmental Sciences*, vol. 20, no. 8, pp. 1006-1011.
- Zhang, B., Zhang, Y., Teng, Y. & Fan, M. 2015, "Sulfate radical and its application in decontamination technologies", *Critical Reviews in Environmental Science and Technology*, vol. 45, no. 16, pp. 1756-1800.

APPENDIX A

RAW DATA

Table S.1. Raw data for *E. coli* inactivation by UV using collimated beam apparatus

TiO <sub>2</sub> concentration (mg/L)	Exposure Time (min)	<i>E. coli</i> log <sub>10</sub> concentration			Corrected UV dose (mJ/cm <sup>2</sup> )	Average Log <sub>10</sub> Concentration	Standard Deviation
		Trial 1	Trial 2	Trial 3			
0	0	5.93	5.85	5.94	0	5.91	0.040
	1	3.35	3.61	3.90	2.4	3.62	0.225
	2	2.10	1.30	1.40	4.8	1.60	0.356
	4	0.60	0.90	0.00	9.6	0.50	0.374
	5	0.00	0.00	0.00	12	0.00	0.000
	10	0.00	0.00	0.00	24	0.00	0.000

Table S.2. Raw data for *E. coli* inactivation by TiO<sub>2</sub> (1 mg/L) -UV using collimated beam apparatus

TiO <sub>2</sub> concentration (mg/L)	Exposure Time (min)	<i>E. coli</i> log <sub>10</sub> concentration			Corrected UV dose (mJ/cm <sup>2</sup> )	Average Log <sub>10</sub> Concentration	Standard Deviation
		Trial 1	Trial 2	Trial 3			
1	0	7.14	6.47	6.53	0	6.71	0.303
	1	4.06	3.56	3.85	2.4	3.82	0.205
	2	2.59	2.44	2.41	4.8	2.48	0.079
	4	1.69	1.18	1.15	9.6	1.34	0.248
	5	1.29	0.85	0.95	12	1.03	0.188
	10	0.18	0.00	0.18	24	0.12	0.085

Table S.3. Raw data for *E. coli* inactivation by TiO<sub>2</sub> (10 mg/L) -UV using collimated beam apparatus

TiO <sub>2</sub> concentration (mg/L)	Exposure Time (min)	<i>E. coli</i> log <sub>10</sub> concentration			Corrected UV dose (mJ/cm <sup>2</sup> )	Average Log <sub>10</sub> Concentration	Standard Deviation
		Trial 1	Trial 2	Trial 3			
10	0	6.59	6.47	6.41	0	6.49	0.075
	1	4.16	4.04	4.26	2.4	4.15	0.090
	2	2.53	2.06	2.22	4.8	2.27	0.195
	4	1.27	0.65	0.18	9.6	0.70	0.446
	5	1.15	0.48	0.18	12	0.60	0.405
	10	0.40	0.00	0.00	24	0.13	0.189

Table S.4. Raw data for *E. coli* inactivation by TiO<sub>2</sub> (40 mg/L) -UV using collimated beam apparatus

TiO <sub>2</sub> concentration (mg/L)	Exposure Time (min)	<i>E. coli</i> log <sub>10</sub> concentration			Corrected UV dose (mJ/cm <sup>2</sup> )	Average Log <sub>10</sub> Concentration	Standard Deviation
		Trial 1	Trial 2	Trial 3			
40	0	7.62	6.87	7.06	0	7.18	0.318
	1	6.80	5.49	4.81	2.4	5.70	0.826
	2	5.68	4.13	3.82	4.8	4.54	0.814
	4	5.19	3.62	3.26	9.6	4.02	0.838
	5	5.15	3.21	2.30	12	3.55	1.189
	10	3.21	1.54	1.18	24	1.98	0.884

Table S.5. Raw data for possible *E. coli* degradation in contact with TiO<sub>2</sub> (1 mg/L) in dark room

TiO <sub>2</sub> concentration (mg/L)	Contact Time (min)	<i>E. coli</i> log <sub>10</sub> concentration			Average Log <sub>10</sub> Concentration	Standard Deviation
		Trial 1	Trial 2	Trial 3		
1	0	6.87	6.93	6.89	6.90	0.025
	1	6.82	6.88	6.91	6.87	0.037
	2	6.90	6.92	6.92	6.91	0.009
	4	6.84	6.91	6.90	6.88	0.031
	5	6.85	6.89	6.88	6.87	0.017
	10	6.89	6.91	6.85	6.88	0.025

Table S.6. Raw data for *E. coli* degradation in contact with TiO<sub>2</sub> (10 mg/L) in dark room

TiO <sub>2</sub> concentration (mg/L)	Contact Time (min)	<i>E. coli</i> log <sub>10</sub> concentration			Average Log <sub>10</sub> Concentration	Standard Deviation
		Trial 1	Trial 2	Trial 3		
10	0	6.98	6.93	7.01	6.97	0.033
	1	6.90	6.95	6.96	6.94	0.026
	2	6.91	6.92	6.94	6.92	0.012
	4	6.90	6.95	6.96	6.94	0.026
	5	6.96	6.91	6.97	6.95	0.026
	10	6.90	6.91	6.97	6.93	0.031

Table S.7. Raw data for possible *E. coli* degradation in contact with TiO<sub>2</sub> (40 mg/L) in dark room

TiO <sub>2</sub> concentration (mg/L)	Contact Time (min)	<i>E. coli</i> log <sub>10</sub> concentration			Average Log <sub>10</sub> Concentration	Standard Deviation
		Trial 1	Trial 2	Trial 3		
40	0	7.03	6.98	7.00	7.00	0.021
	1	7.02	6.96	7.00	6.99	0.025
	2	6.77	7.01	6.98	6.92	0.107
	4	6.83	6.96	6.96	6.92	0.061
	5	6.88	6.86	6.96	6.90	0.043
	10	7.12	6.87	6.92	6.97	0.108

Table S.8. Raw data for P22 inactivation by UV using collimated beam apparatus

TiO <sub>2</sub> Concentration (mg/L)	Exposure Time (min)	P22 log <sub>10</sub> concentration			UV dose (mJ/cm <sup>2</sup> )	Average Log <sub>10</sub> Concentration	Standard Deviation
		Trial 1	Trial 2	Trial 3			
0	0	6.48	6.51	6.29	0	6.43	0.097
	1	5.61	5.68	5.51	2.4	5.60	0.070
	2	4.75	4.69	4.43	4.8	4.62	0.139
	4	2.78	2.42	2.52	9.6	2.57	0.152
	5	1.75	1.26	1.15	12	1.39	0.261
	10	0.30	0.00	0.00	24	0.10	0.141
	15	0.00	0.00	0.00	36	0.00	0.000

Table S.9. Raw data for P22 inactivation by TiO<sub>2</sub> (1 mg/L)-UV using collimated beam apparatus

TiO <sub>2</sub> Concentration (mg/L)	Exposure Time (min)	P22 log <sub>10</sub> concentration			UV dose (mJ/cm <sup>2</sup> )	Average Log <sub>10</sub> Concentration	Standard Deviation
		Trial 1	Trial 2	Trial 3			
1	0	6.45	6.36	6.57	0	6.46	0.086
	1	5.39	5.42	5.45	2.4	5.42	0.024
	2	4.64	4.54	4.75	4.8	4.64	0.086
	4	2.41	2.29	2.51	9.6	2.40	0.090
	5	1.90	1.04	1.54	12	1.49	0.353
	10	0.00	0.00	0.30	24	0.10	0.141
	15	0.00	0.00	0.00	36	0.00	0.000

Table S.10. Raw data for P22 inactivation by TiO<sub>2</sub> (10 mg/L)-UV using collimated beam apparatus

TiO <sub>2</sub> Concentration (mg/L)	Exposure Time (min)	P22 log <sub>10</sub> concentration			UV dose (mJ/cm <sup>2</sup> )	Average Log <sub>10</sub> Concentration	Standard Deviation
		Trial 1	Trial 2	Trial 3			
10	0	6.42	6.56	6.45	0	6.48	0.060
	1	5.57	5.57	5.58	2.4	5.57	0.005
	2	4.77	4.88	4.86	4.8	4.84	0.048
	4	2.51	2.95	2.77	9.6	2.74	0.181
	5	1.38	1.71	2.21	12	1.77	0.341
	10	0.00	0.80	1.23	24	0.68	0.510
	15	0.00	0.30	0.95	36	0.42	0.397



Table S.11. Raw data for P22 inactivation by TiO<sub>2</sub> (40 mg/L)-UV using collimated beam apparatus

TiO <sub>2</sub> Concentration (mg/L)	Exposure Time (min)	P22 log <sub>10</sub> concentration			UV dose (mJ/cm <sup>2</sup> )	Average Log <sub>10</sub> Concentration	Standard Deviation
		Trial 1	Trial 2	Trial 3			
40	0.00	6.77	6.46	6.43	0.00	6.55	0.15
	1.00	5.96	5.45	5.79	2.40	5.73	0.21
	2.00	5.19	4.89	5.26	4.80	5.11	0.16
	4.00	3.32	3.16	3.49	9.60	3.32	0.13
	5.00	2.15	2.20	2.54	12.00	2.30	0.17
	10.00	0.81	0.48	1.34	24.00	0.88	0.35
	15.00	0.40	0.30	1.00	36.00	0.57	0.31

Table S.12. Raw data for possible P22 degradation in contact with TiO<sub>2</sub> (1 mg/L) in dark room

TiO <sub>2</sub> concentration (mg/L)	Contact Time (min)	P22 log <sub>10</sub> concentration			Average Log <sub>10</sub> Concentration	Standard Deviation
		Expr 1	Expr 2	Expr 3		
1	0	6.87	6.93	6.89	6.90	0.025
	1	6.82	6.88	6.91	6.87	0.037
	2	6.90	6.92	6.92	6.91	0.009
	4	6.84	6.91	6.90	6.88	0.031
	5	6.85	6.89	6.88	6.87	0.017
	10	6.89	6.91	6.85	6.88	0.025

Table S.13. Raw data for possible P22 degradation in contact with TiO<sub>2</sub> (10 mg/L) in dark room

TiO <sub>2</sub> concentration (mg/L)	Contact Time (min)	P22 log <sub>10</sub> concentration			Average Log <sub>10</sub> Concentration	Standard Deviation
		Trial 1	Trial 2	Trial 3		
10	0	6.531	6.357	5.902	6.263	0.265
	1	6.385	6.381	6.077	6.281	0.144
	2	6.001	6.457	6.360	6.273	0.196
	4	6.275	7.003	5.530	6.269	0.601
	5	6.257	6.341	6.127	6.242	0.088
	10	6.180	6.201	6.238	6.206	0.024
	15	6.371	6.256	6.165	6.264	0.084

Table S.14. Raw data for possible P22 degradation in contact with TiO<sub>2</sub> (40 mg/L) in dark room

TiO <sub>2</sub> concentration (mg/L)	Contact Time (min)	P22 log <sub>10</sub> concentration			Average Log <sub>10</sub> Concentration	Standard Deviation
		Expr 1	Expr 2	Expr 3		
40	0	7.03	6.98	7.00	7.00	0.021
	1	7.02	6.96	7.00	6.99	0.025
	2	6.77	7.01	6.98	6.92	0.107
	4	6.83	6.96	6.96	6.92	0.061
	5	6.88	6.86	6.96	6.90	0.043
	10	7.12	6.87	6.92	6.97	0.108

Table S.15. Raw water quality-related data for bench-scale UV experiments

TiO <sub>2</sub> concentration (mg/L)	Mean TiO <sub>2</sub> particles diameter (nm)	Turbidity (NTU)	UVA (%)	UVT (%)
	-	0.980	0.073	84.53
	-	1.030	0.077	83.75
	-	1.080	0.079	83.37
0	Average			
	-	1.030	0.076	83.88

Table S.16. Raw water quality-related data for bench-scale TiO<sub>2</sub> (1 mg/L)-UV experiments

TiO <sub>2</sub> concentration (mg/L)	Mean TiO <sub>2</sub> particles diameter (nm)	Turbidity (NTU)	UVA (%)	UVT (%)
	2278.2	6.250	0.077	83.753
	2538.7	6.180	0.077	83.753
	3750.2	6.200	0.076	83.946
1	Average			
	2855.7	6.210	0.077	83.817

Table S.17. Raw water quality-related data for bench-scale TiO<sub>2</sub> (10 mg/L)-UV experiments

TiO <sub>2</sub> concentration (mg/L)	Mean TiO <sub>2</sub> particles diameter (nm)	Turbidity (NTU)	UVA (%)	UVT (%)
	4477.6	25.600	0.073	84.528
	2097.3	29.300	0.076	83.946
	2406.1	27.500	0.075	84.140
10	Average			
	2993.7	27.467	0.075	84.204

Table S.18. Raw water quality-related data for bench-scale TiO<sub>2</sub> (40 mg/L)-UV experiments

TiO <sub>2</sub> concentration (mg/L)	Mean TiO <sub>2</sub> particles diameter (nm)	Turbidity (NTU)	UVA (%)	UVT (%)
	2179.4	97.000	0.073	84.528
	1888.1	103.000	0.073	84.528
40	1790.2	108.000	0.073	84.528
	Average			
	1952.6	102.667	0.073	84.528

Table S.19. Raw data for *E. coli* inactivation by PAA (0.25 mg/L) -UV using collimated beam apparatus

PAA Concentration (mg/L)	Exposure Time (min)	<i>E. coli</i> log <sub>10</sub> concentration			Corrected UV dose (mJ/cm <sup>2</sup> )	Average Log <sub>10</sub> Concentration	Standard Deviation
		Trial 1	Trial 2	Trial 3			
0.25	0	6.63	6.64	6.71	0	6.66	0.04
	1	3.08	3.11	3.27	2.4	3.15	0.08
	2	1.40	1.53	1.54	4.8	1.49	0.06
	4	0.00	0.00	0.00	9.6	0.00	0.00
	5	0.00	0.00	0.00	12	0.00	0.00
	10	0.00	0.00	0.00	24	0.00	0.00

Table S.20. Raw data for *E. coli* inactivation by PAA (0.5 mg/L) -UV using collimated beam apparatus

PAA Concentration (mg/L)	Exposure Time (min)	<i>E. coli</i> log <sub>10</sub> concentration			Corrected UV dose (mJ/cm <sup>2</sup> )	Average Log <sub>10</sub> Inactivation	Standard Deviation
		Trial 1	Trial 2	Trial 3			
0.5	0	6.61	6.63	6.75	0	6.66	0.06
	1	2.23	2.21	2.49	2.4	2.31	0.13
	2	0.00	0.00	0.00	4.8	0.00	0.00
	4	0.00	0.00	0.00	9.6	0.00	0.00
	5	0.00	0.00	0.00	12	0.00	0.00
	10	0.00	0.00	0.00	24	0.00	0.00

Table S.21. Raw data for possible *E. coli* degradation in contact with PAA (0.25 mg/L) in dark room

PAA concentration (mg/L)	Contact Time (min)	<i>E. coli</i> log <sub>10</sub> concentration			Average Log <sub>10</sub> Concentration	Standard Deviation
		Trial 1	Trial 2	Trial 3		
0.25	0	6.69	6.91	6.19	6.60	0.301
	2	6.21	6.54	6.88	6.54	0.274
	5	6.74	6.34	6.67	6.58	0.174

Table S.22. Raw data for possible *E. coli* degradation in contact with PAA (0.5 mg/L) in dark room

PAA concentration (mg/L)	Contact Time (min)	<i>E. coli</i> log <sub>10</sub> concentration			Average Log <sub>10</sub> Concentration	Standard Deviation
		Trial 1	Trial 2	Trial 3		
0.5	0	6.87	6.54	6.85	6.75	0.151
	2	6.74	6.75	6.31	6.60	0.205
	5	6.55	6.69	6.43	6.56	0.106

Table S.23. Raw data for P22 inactivation by PAA (0.25 mg/L) -UV using collimated beam apparatus

PAA Concentration (mg/L)	Exposure Time (min)	P22 log <sub>10</sub> concentration			UV dose (mJ/cm <sup>2</sup> )	Average Log <sub>10</sub> Concentration	Standard Deviation
		Trial 1	Trial 2	Trial 3			
0.25	0	6.62	6.76	6.77	0	6.72	0.068
	1	5.51	5.57	5.74	2.4	5.61	0.097
	2	4.41	4.69	4.95	4.8	4.68	0.221
	4	2.46	3.05	2.87	9.6	2.79	0.247
	5	0.93	1.95	1.58	12	1.49	0.422
	10	0.00	0.00	0.00	24	0.00	0.000
	15	0.00	0.00	0.00	36	0.00	0.000

Table S.24. Raw data for P22 inactivation by PAA (0.5 mg/L) -UV using collimated beam apparatus

PAA Concentration (mg/L)	Exposure Time (min)	P22 log <sub>10</sub> concentration			UV dose (mJ/cm <sup>2</sup> )	Average Log <sub>10</sub> Concentration	Standard Deviation
		Trial 1	Trial 2	Trial 3			
0.5	0	6.66	6.74	6.73	0	6.71	0.036
	1	5.87	5.72	5.64	2.4	5.74	0.095
	2	5.00	4.94	4.85	4.8	4.93	0.062
	4	2.89	2.88	2.85	9.6	2.87	0.017
	5	1.81	1.74	1.76	12	1.77	0.029
	10	0.00	0.00	0.00	24	0.00	0.000
	15	0.00	0.00	0.00	36	0.00	0.000

Table S.25. Raw data for P22 inactivation by PAA (1 mg/L) -UV using collimated beam apparatus

PAA Concentration (mg/L)	Exposure Time (min)	P22 log <sub>10</sub> concentration			UV dose (mJ/cm <sup>2</sup> )	Average Log <sub>10</sub> Concentration	Standard Deviation
		Trial 1	Trial 2	Trial 3			
1	0	6.81	6.77	6.77	0	6.78	0.019
	1	5.89	5.69	5.69	2.4	5.76	0.094
	2	4.92	4.67	4.62	4.8	4.74	0.131
	4	2.36	2.10	2.27	9.6	2.24	0.108
	5	0.81	0.81	0.70	12	0.77	0.052
	10	0.00	0.00	0.00	24	0.00	0.000
	15	0.00	0.00	0.00	36	0.00	0.000

Table S.26. Raw data for P22 inactivation by PAA (10 mg/L) -UV using collimated beam apparatus

PAA Concentration (mg/L)	Exposure Time (min)	P22 log <sub>10</sub> concentration			UV dose (mJ/cm <sup>2</sup> )	Average Log <sub>10</sub> Concentration	Standard Deviation
		Trial 1	Trial 2	Trial 3			
10	0	6.77	6.84	6.74	0	6.78	0.042
	1	5.23	5.06	5.20	2.4	5.16	0.074
	2	3.55	3.23	3.48	4.8	3.42	0.137
	4	0.70	0.00	0.00	9.6	0.23	0.330
	5	0.00	0.00	0.00	12	0.00	0.000
	10	0.00	0.00	0.00	24	0.00	0.000
	15	0.00	0.00	0.00	36	0.00	0.000

Table S.27. Raw data for possible P22 degradation in contact with PAA (0.25 mg/L) in dark room

PAA concentration (mg/L)	Contact Time (min)	P22 log <sub>10</sub> Concentration			Average Log <sub>10</sub> Concentration	Standard Deviation
		Trial 1	Trial 2	Trial 3		
0.25	0	6.91	6.92	7.02	6.95	0.05
	1	6.9	6.9	6.99	6.93	0.04242641
	5	6.85	6.96	7.04	6.95	0.078
	10	6.97	6.84	6.95	6.92	0.057

Table S.28. Raw data for possible P22 degradation in contact with PAA (0.5 mg/L) in dark room

PAA concentration (mg/L)	Contact Time (min)	P22 log <sub>10</sub> Concentration			Average Log <sub>10</sub> Concentration	Standard Deviation
		Trial 1	Trial 2	Trial 3		
0.5	0	6.86	7.09	7.2	7.05	0.142
	1	7.11	7.03	7.1	7.08	0.03559026
	5	7.09	7.11	6.86	7.02	0.113
	10	7.11	7.02	6.87	7	0.099

Table S.29. Raw data for possible P22 degradation in contact with PAA (1 mg/L) in dark room

PAA concentration (mg/L)	Contact Time (min)	P22 log <sub>10</sub> Concentration			Average Log <sub>10</sub> Concentration	Standard Deviation
		Trial 1	Trial 2	Trial 3		
1	0	6.67	6.93	6.95	6.85	0.128
	1	6.74	6.94	6.99	6.89	0.10801234
	5	6.89	6.98	6.65	6.84	0.139
	10	6.89	6.82	6.72	6.81	0.07



Table S.30. Raw data for possible P22 degradation in contact with PAA (10 mg/L) in dark room

PAA concentration (mg/L)	Contact Time (min)	P22 log <sub>10</sub> Concentration			Average Log <sub>10</sub> Concentration	Standard Deviation
		Trial 1	Trial 2	Trial 3		
10	0	6.53	7.03	6.51	6.69	0.24055491
	1	6.15	6.97	6.65	6.59	0.33744135
	5	5.42	5.73	5.71	5.62	0.14165686
	10	3.96	3.84	3.78	3.86	0.07483315

Table S.31. Raw water quality-related data for bench-scale PAA (0 mg/L)-UV experiments

PAA Concentration (mg/L)	Turbidity (NTU)	UVT (%)	pH
0	0.98	83.56	7.53
	1.03	84.92	7.51
	1.08	83.56	7.5
	Average		
	1.03	84.01	7.51

Table S.32. Raw water quality-related data for bench-scale PAA (0.25 mg/L)-UV experiments

PAA Concentration (mg/L)	Turbidity (NTU)	UVT (%)	pH after Injecting PAA
0.25	1.05	83.56	7.43
	1.02	85.31	7.53
	1.07	85.11	7.48
	Average		
	1.05	84.66	7.48

Table S.33. Raw water quality-related data for bench-scale PAA (0.5 mg/L)-UV experiments

PAA Concentration (mg/L)	Turbidity (NTU)	UVT (%)	pH after Injecting PAA
0.5	0.83	84.72	7.41
	1.01	85.51	7.45
	1.04	84.13	7.58
	Average		
	0.96	84.79	7.48

Table S.34. Raw water quality-related data for bench-scale PAA (1 mg/L)-UV experiments

PAA Concentration (mg/L)	Turbidity (NTU)	UVT (%)	pH after Injecting PAA
1	1.04	84.23	7.43
	1.07	83.98	7.58
	1.05	84.66	7.4
	Average		
	1.05	84.29	7.47

Table S.35. Raw water quality-related data for bench-scale PAA (10 mg/L)-UV experiments

PAA Concentration (mg/L)	Turbidity (NTU)	UVT (%)	pH after Injecting PAA
10	0.99	83.52	7.45
	1.12	84.21	7.39
	1.1	84.38	7.3
	Average		
	1.07	84.04	7.38

Table S.36. Raw data for P22 inactivation by UV using Photo-Cat

TiO <sub>2</sub> Concentration (mg/L)	Sampling Time (min)	P22 log <sub>10</sub> Concentration			UV Lamp Energy (kWh/m <sup>3</sup> )	Average log <sub>10</sub> concentration	standard deviation
		Trial 1	Trial 2	Trial 3			
0	0	5.68	6.00	5.80	0.00	5.83	0.132
	1	5.49	5.41	5.04	1.83	5.31	0.196
	2	4.45	4.85	4.87	3.67	4.72	0.193
	4	4.23	4.14	4.50	7.33	4.29	0.153
	5	3.80	4.31	4.35	9.17	4.15	0.250
	10	3.83	4.28	4.54	18.33	4.22	0.293

Table S.37. Raw data for P22 inactivation by TiO<sub>2</sub> (1 mg/L)-UV using Photo-Cat

TiO <sub>2</sub> Concentration (mg/L)	Sampling Time (min)	P22 log <sub>10</sub> Concentration			UV Lamp Energy (kWh/m <sup>3</sup> )	Average log <sub>10</sub> concentration	standard deviation
		Trial 1	Trial 2	Trial 3			
1	0	5.81	5.67	5.71	0.00	5.73	0.059
	1	5.36	5.50	5.38	1.83	5.41	0.062
	2	4.62	5.34	4.83	3.67	4.93	0.302
	4	4.57	4.93	4.67	7.33	4.72	0.152
	5	4.52	4.53	4.69	9.17	4.58	0.078
	10	4.01	3.97	4.18	18.33	4.05	0.091

Table S.38. Raw data for P22 inactivation by TiO<sub>2</sub> (10 mg/L)-UV using Photo-Cat

TiO <sub>2</sub> Concentration (mg/L)	Sampling Time (min)	P22 log <sub>10</sub> Concentration			UV Lamp Energy (kWh/m <sup>3</sup> )	Average log <sub>10</sub> concentration	standard deviation
		Trial 1	Trial 2	Trial 3			
10	0	5.60	5.59	5.63	0.00	5.61	0.017
	1	5.09	5.12	5.16	1.83	5.12	0.029
	2	4.79	4.94	4.68	3.67	4.80	0.107
	4	4.28	4.31	4.35	7.33	4.31	0.029
	5	4.16	4.07	4.22	9.17	4.15	0.062
	10	4.08	3.67	4.50	18.33	4.08	0.339

Table S.39. Raw data for P22 inactivation by TiO<sub>2</sub> (40 mg/L)-UV using Photo-Cat

TiO <sub>2</sub> Concentration (mg/L)	Sampling Time (min)	P22 log <sub>10</sub> Concentration			UV Lamp Energy (kWh/m <sup>3</sup> )	Average log <sub>10</sub> concentration	standard deviation
		Trial 1	Trial 2	Trial 3			
40	0	5.36	5.31	5.69	0.00	5.45	0.169
	1	4.76	4.79	4.79	1.83	4.78	0.014
	2	3.85	4.34	3.91	3.67	4.03	0.218
	4	3.18	4.30	3.66	7.33	3.71	0.459
	5	2.88	4.26	3.54	9.17	3.56	0.564
	10	2.82	3.74	3.82	18.33	3.46	0.454

Table S.40. Raw water quality-related data for pilot-scale TiO<sub>2</sub> (0 mg/L)-UV experiments using Photo-Cat

TiO <sub>2</sub> Concentration (mg/L)	Influent Turbidity (NTU)	Effluent Turbidity (NTU)	Influent UVT (%)	Effluent pH
0	0.01	0.01	99.31	7.6
	0.01	0.01	95.72	8.0
	0.02	0.03	91.34	8.4
	Average			
	0.01	0.01	95.46	8.0

Table S.41. Raw water quality-related data for pilot-scale TiO<sub>2</sub> (1 mg/L)-UV experiments using Photo-Cat

TiO <sub>2</sub> Concentration (mg/L)	TiO <sub>2</sub> particles size in DI water (nm)	Influent Turbidity (NTU)	Effluent Turbidity (NTU)	Influent UVT (%)	Effluent pH
1	677.4	4.73	0.07	99.62	7.7
	1152.3	4.97	0.07	99.69	7.6
	551.1	4.72	0.07	99.62	7.6
	Average				
	793.6	4.81	0.07	99.64	7.6

Table S.42. Raw water quality-related data for pilot-scale TiO<sub>2</sub> (10 mg/L)-UV experiments using Photo-Cat

TiO <sub>2</sub> Concentration (mg/L)	TiO <sub>2</sub> particles size in DI water (nm)	Influent Turbidity (NTU)	Effluent Turbidity (NTU)	Influent UVT (%)	Effluent pH
10	558.9	45.57	0.09	99.62	7.2
	581.5	46.60	0.07	99.46	7.0
	587.1	46.20	0.06	99.62	7.6
	99.61				
	575.8	46.12	0.07	99.56	7.3

Table S.43. Raw water quality-related data for pilot-scale TiO<sub>2</sub> (40 mg/L)-UV experiments using Photo-Cat

TiO <sub>2</sub> Concentration (mg/L)	TiO <sub>2</sub> particles size in DI water (nm)	Influent Turbidity (NTU)	Effluent Turbidity (NTU)	Influent UVT (%)	Effluent pH
40	495.6	155.66	0.06	99.62	7.6
	494.1	155.00	0.07	99.54	8.0
	482.7	157.03	0.07	99.38	8.4
	Average				
	490.8	155.90	0.07	99.51	8.0

Table S.44. Raw data for *E. coli* inactivation by PAA-UV AOP using D222 UV device

D222 UV Device from NoTech Aqua Solutions	Trial Number	UV dose (mJ/cm <sup>2</sup> )	Average UV dose (mJ/cm <sup>2</sup> )	<i>E. coli</i> log <sub>10</sub> inactivation	Average <i>E. coli</i> log <sub>10</sub> inactivation	Standard Deviation of inactivation
UV alone (16.76 mJ/cm <sup>2</sup> )	1	16.56	16.76	7.9	7.90	0.082
	2	16.63		7.8		
	3	17.08		8		
UV + 0.25 mg/L PAA (16.13 mJ/cm <sup>2</sup> )	1	16.48	16.13	9.40	> 8.90	0.354
	2	16.04		8.67		
	3	15.88		8.63		
UV + 0.5 mg/L PAA (16.04 mJ/cm <sup>2</sup> )	1	15.89	16.04	9.75	> 9.01	0.526
	2	15.89		8.60		
	3	16.33		8.67		
UV + 10 mg/L PAA (15.04 mJ/cm <sup>2</sup> )	1	14.92	15.04	9.2	> 9.11	0.11
	2	15.29		8.95		
	3	14.92		9.17		

Table S.45. Raw data for P22 inactivation by PAA-UV AOP using D222 UV device

D222 UV Device from NeoTech Aqua Solutions	Trial Number	UV dose (mJ/cm <sup>2</sup> )	Average UV dose (mJ/cm <sup>2</sup> )	P22 log <sub>10</sub> inactivation	Average P22 log <sub>10</sub> inactivation	Standard Deviation of inactivation
UV alone (16.76 mJ/cm <sup>2</sup> )	1	16.56	16.76	3.94	4.00	0.059
	2	16.63		4.08		
	3	17.08		3.98		
UV + 0.25 mg/L PAA (16.13 mJ/cm <sup>2</sup> )	1	16.48	16.13	2.85	2.86	0.090
	2	16.04		2.76		
	3	15.88		2.98		
UV + 0.5 mg/L PAA (16.04 mJ/cm <sup>2</sup> )	1	15.89	16.04	3.28	3.05	0.340
	2	15.89		2.57		
	3	16.33		3.30		
UV + 10 mg/L PAA (15.04 mJ/cm <sup>2</sup> )	1	14.92	15.04	3.48	3.54	0.04
	2	15.29		3.57		
	3	14.92		3.56		

Table S.46. Raw data for P22 inactivation by UV using D222 UV device

D222 UV Device from NeoTech Aqua Solutions	Trial #	UV dose (mJ/cm <sup>2</sup> )	Average UV dose (mJ/cm <sup>2</sup> )	P22 log <sub>10</sub> concentration		P22 log <sub>10</sub> inactivation	Average P22 log <sub>10</sub> inactivation	Standard Deviation of inactivation
				Inlet	Outlet			
UV alone (23.12 mJ/cm <sup>2</sup> )	1	23.49	23.12	6.05	0	6.05	> 6.15	0.074
	2	22.75		6.22	0	6.22		
	3	23.12		6.19	0	6.19		

Table S.47. Raw water quality-related data of influent for pilot-scale PAA-UV experiments using D222 UV device

Experiment	Trial #	Influent Turbidity (NTU)	Influent UVT (%)	Influent DOC (mg/L)	Influent pH
UV	Trial 1	2.150	80.353	37.09	7.68
	Trial 2	2.100	78.886	36.22	7.67
	Trial 3	2.190	77.090	36.32	7.67
Average	-	2.147	78.776	36.543	7.673
UV+ 0.25 mg/L PAA	Trial 1	2.140	77.983	36.930	7.670
	Trial 2	2.120	79.616	36.520	7.670
	Trial 3	2.160	78.524	36.320	7.650
Average	-	2.140	78.708	36.590	7.663
UV+ 0.5 mg/L PAA	Trial 1	2.110	79.616	37.040	7.640
	Trial 2	2.190	79.068	36.130	7.660
	Trial 3	2.100	79.068	35.940	7.640
Average	-	2.133	79.251	36.370	7.647
UV+ 10 mg/L PAA	Trial 1	2.180	79.983	36.440	7.650
	Trial 2	2.450	80.538	36.260	7.680
	Trial 3	2.250	79.616	35.960	7.660
Average	-	2.293	80.046	36.220	7.663



Table S.48. Raw water quality-related data of effluent for pilot-scale PAA-UV experiments using D222 UV device

Experiment	Trial #	Effluent Turbidity (NTU)	Effluent UVA (%)	Effluent UVT (%)	Effluent DOC (mg/L)	Effluent pH
UV	Trial 1	2.280	0.117	76.384	34.900	7.640
	Trial 2	2.140	0.109	77.804	35.270	7.670
	Trial 3	2.200	0.102	79.068	34.910	7.670
Average	-	2.207	0.109	77.752	35.027	7.660
UV+ 0.25 mg/L PAA	Trial 1	2.800	0.099	79.616	37.64	7.630
	Trial 2	1.900	0.099	79.616	37.74	7.640
	Trial 3	1.870	0.101	79.250	38.16	7.640
Average	-	2.190	0.100	79.494	37.847	7.637
UV+ 0.5 mg/L PAA	Trial 1	1.950	0.097	79.983	38	7.640
	Trial 2	1.890	0.103	78.886	37.89	7.640
	Trial 3	1.920	0.097	79.983	37.95	7.600
Average	-	1.920	0.099	79.618	37.947	7.627
UV+ 10 mg/L PAA	Trial 1	2.470	0.118	76.208	45.61	7.540
	Trial 2	2.480	0.122	75.509	45.58	7.520
	Trial 3	2.570	0.137	72.946	46.15	7.500
Average	-	2.507	0.126	74.888	45.780	7.520