

Detection of Back-Fed Ground Faults
Using Smart Grid Distribution Technology

by

Geir Magne Abusdal

A Thesis Presented in Partial Fulfillment
of the Requirements for the Degree
Master of Science

Approved November 2014 by the
Graduate Supervisory Committee:

Gerald Heydt, Chair
Raja Ayyanar
George Karady

ARIZONA STATE UNIVERSITY

December 2014

ABSTRACT

The safety issue in an electrical power distribution system is of critical importance. In some circumstances, even the continuity of service has to be compromised for a situation that can cause a hazard to the public. A downed conductor that creates an electrical path between a current carrying conductor and ground pose a potential lethal hazard to anyone in the near proximity. Electric utilities have yet to find a fully accepted and reliable method for detecting downed conductors even with decades of research.

With the entry of more automation and a smarter grid in the different layers of distribution power system supply, new doors are being opened and new feasible solutions are waiting to be explored. The 'big data' and the infrastructures that are readily accessible through the smart metering system is the base of the work and analysis performed in this thesis. In effect, the new technologies and new solutions are an artifact of the Smart Grid effort which has now reached worldwide dimensions. A solution to problems of overhead distribution conductor failures / faults that use simple methods and that are easy to implement using existing and future distribution management systems is presented.

A European type distribution system using three phase supply is utilized as the test bed for the concepts presented. Fault analysis is performed on the primary and the secondary distribution system using the free downloadable software OpenDSS. The outcome is a set of rules that can be implemented either locally or central using a voltage based method. Utilized in the distribution management systems the operators will be given a powerful tool to make the correct action when a situation occurs. The test bed itself is taken from an actual system in Norway.

ACKNOWLEDGEMENTS

Initially I would like to thank my employer, Agder Energi Nett (AEN), for giving the financial assistance and the opportunity to pursue an M.S. study and research at Arizona State University (ASU). In particular I would like to express my sincere gratitude towards Atle Ripegutú at AEN who came up with the idea of the research subject and the continuing support in technical discussion throughout the research.

I greatly appreciate that my advisor and chair, Dr. Gerald T. Heydt once again were able to give me the opportunity to work with him 17 years after guiding me through the completion of the bachelor's degree. With the immense wide area of knowledge within the power engineering area and the patient guidance he has made it possible for me to complete this thesis. I would also thank Dr. Raja Ayyanar and Dr. George Karady for giving their time and effort through being a part of my graduate supervisory committee.

I would like to acknowledge and thank Nortroll AS in Norway for giving technical assistance and input through correspondence and providing useful documentation on the area of subject.

Last but not least, I am forever thankful to my lovely wife, Ingvild-Jorna Bø Abusdal, and my two wonderful kids, Nina Marie and Kristian. Their presence, love and support has given me the time and motivation throughout the process of completing this master's degree.

TABLE OF CONTENTS

	Page
LIST OF TABLES	v
LIST OF FIGURES	vi
NOMENCLATURE	vii
CHAPTER	
1 FAULTS IN ELECTRIC POWER DISTRIBUTION SYSTEMS.....	1
1.1 Scope and Objectives	1
1.2 Background	2
1.3 Distribution Power System / Norwegian Power System Design	3
1.4 Compensated Distribution Systems and Petersen Coils.....	9
1.5 Broken and Downed Conductors	12
1.6 Open Distribution System Simulator (OpenDSS) Analysis Tool	14
1.7 Organization of This Thesis	17
2 MODELING AND ANALYSIS OF DISTRIBUTION SYSTEMS	18
2.1 Primary Distribution System Components.....	18
2.2 Secondary Distribution System Components.....	19
2.3 Transformer Modeling	20
2.4 Peterson Coil Modeling.....	26
2.5 Load Modeling	28
2.6 Line Modeling	28
2.7 Analyzing Broken Conductors and Back-Fed Ground Fault	29
2.8 Analyzing Single Line-Ground Faults	30

CHAPTER	Page
3	EXAMPLES OF THE FAULT DETECTION METHODOLOGY AND EVALUATION OF THE METHOD31
3.1	Distribution System Sample Case / Test Bed.....31
3.2	Example 1 – Broken Conductor Primary Distribution System35
3.3	Example 2 – Back-Fed Ground Fault in Primary Distribution System.....40
3.4	Example 3 – Single Line-Ground Fault Primary Distribution System46
3.5	Example 4 – Single Line-Ground Fault Secondary Distribution System ...47
3.6	Example 5 – Two Line-Ground Fault Fault Primary Distribution System .50
3.7	Algorithms and System Overview for Detection51
3.8	Evaluating and Comparing Results56
4	CONCLUSIONS, REMARKS AND RECOMMENDATIONS FOR FUTURE WORK59
4.1	Concluding Remarks59
4.2	Recommendations for Future Work61
	REFERENCES62
	APPENDIX
A	OPENDSS CODE69

LIST OF TABLES

Table	Page
2.1 Distribution Transformers and Vector Groups	22
3.1 Distribution Transformers.....	33
3.2 A Set of Examples Used for Simulation and Evaluation.....	34
3.3 Test-Bed Results for Voltages [p.u.] at Selected Buses with Normal Operation	35
3.4 Broken Conductor Line 6 Phase 1 For Case 1 in Example 1.....	36
3.5 Broken Conductor Line 20 Phase 1 For Case 2 in Example 1.....	37
3.6 Summary of Results for Broken Conductor Example 1	38
3.7 Voltage Vectors for Broken Conductor Example 1	39
3.8 Back-Fed Ground Fault Phase 1 Line 6 – Case 1	41
3.9 Back-Fed Ground Fault Phase 1 On Line 20 – Case 2	42
3.10 Back-Fed Ground Fault Close to Distribution Transformers – Case 3.....	43
3.11 Summarized Result Back-Fed Ground Fault – Example 2.....	44
3.12 Voltage Vectors for Back-Fed Ground Fault - Example 2	45
3.13 Single Line-Ground Fault in Phase 1 for MV System Bus 6 – Example 3	47
3.14 Single Line-Ground Fault in Phase 1 for LV Side of Transformer 13	48
3.15 Single Line-Ground Fault in Phase 1 for LV Side of Transformers – Example 4.	49
3.16 Double Line-Ground Fault at Bus 6 in MV System – Example 5	50

LIST OF FIGURES

Figure	Page
1.1 Distribution Substation Feeder Design.....	3
1.2 Sample Norwegian Distribution System In Urban Area	5
1.3 Sample Norwegian Distribution System In Rural Area	5
1.4 Secondary Distribution System Configurations	7
1.5 Typical Smart Meter Scheme At Secondary Compact Substation.	8
1.6 Compensated Distribution System With A Single Phase To Ground Fault.....	11
1.7 Downed Conductor/Back-Fed Ground Fault.....	12
1.8 Electrical Representation Of Back-Fed Ground Fault.....	12
1.9 Openss Sample Circuit	15
1.10 Circuit Elements Connections In Openss Sample Circuit.....	16
1.11 Openss Code For Sample Circuit	17
2.1 Transformer Vector Group Connection Dyn11, Dyn5, Yyn0 And Dd0	23
2.2 Sample Distribution Transformer Certificate Showing Test Results [66]	24
2.3 Excerpt From Test Report For A 25 Mva Substation Transformer [66].....	25
2.4 Excerpt From Test Certificate For Petersen Coil /Asc [66]	27
3.1 Distribution System 22 Kv Feeder Test Bed.....	32
3.2 Map Of Northern Europe Taken From [69]	32
3.3 Flow Chart Of Detection Algorithm.....	54
3.4 System Overview For Detection	55

NOMENCLATURE

AMS	Advanced metering system
ASC	Arc suppression coil / Petersen coil
Back-fed ground fault	When the object touching the ground plane in a faulted object is located on the downstream side of the supply and the fault is fed back through a distribution transformer
Big data	Large amounts of data that is produced in a system where a single software tool often is not capable of handling everything.
<i>C</i>	Electrical capacitance
DER	Distributed Energy Resources
DMS	Distribution Management System
Dd0	Vector group of delta-delta transformer connection where LV is in phase with MV
Dyn11	Vector group of delta-wye transformer connection where LV leads MV by 30°
Dyn5	Vector group of delta-wye transformer connection where LV lags MV by 150°
Fault	Any abnormal sudden situation in the operation of a power system
HIF	High impedance fault
HV	High voltage > 35 kV

IT	'Isolated Terra' – isolated neutral to ground. Grounding system for LV distribution system used in Europe (mostly Norway and Albania)
kV	kilovolt
kVA	kilovoltampere
LV	Low voltage < 1kV
MV	Medium voltage $1.0 > V < 35 \text{ kV}$
N	Neutral, finite number, an integer
PE	Protective Earth
PEN	Protective Earth Neutral
p.u.	Per unit, fraction of electrical system quantities over a chosen base unit quantity
MVA _r	Megavoltampere reactive
R	Electrical resistance
R_g	Carson earth return resistance
Rho, ρ	Earth resistivity
RTU	Remote Terminal Unit
SCADA	Supervisory control and data acquisition

Smart Grid	Term used for a modern computerized electrical power system with bi-directional energy transfer and information technology interaction.
TT	‘Terra Terra‘ – solidly grounded neutral. Grounding system for LV distribution system
TN	‘Terra Neutral‘ – solidly grounded neutral where neutral is brought to load. Grounding system for LV distribution system.
TN-C	‘Terra Neutral - Combined‘ – solidly grounded neutral where neutral is brought to load and the neutral and ground are combined. Grounding system for LV distribution system
TN-S	‘Terra Neutral - Separate‘ – solidly grounded neutral where neutral and ground is split at the transformer before brought to load. Grounding system for LV distribution system
TN-C-S	‘Terra Neutral - Combined - Separate‘ – solidly grounded neutral where neutral and ground is split before brought to into the service of load. Grounding system for LV distribution system
Vector group	Classification or categorization of a transformer based on the winding connections of a three phase transformer indicating the phase shift from one winding to another.
X	Electrical reactance, inductive reactance
X_g	Carson earth return reactance
Yyn0	Vector ground of wye-wye transformer connection where both windings are in phase and the neutral for the lower voltage side is brought out
YNyn0	Vector ground of wye-wye transformer connection where both windings are in phase and the neutral for the both sides are brought out

CHAPTER 1

FAULTS IN ELECTRIC POWER DISTRIBUTION SYSTEMS

1.1 Scope and objectives

The main objective of this study is to find a reliable method to detect *back-fed ground faults* using elements of the advanced metering system infrastructure. In this context a ground fault is said to occur when a part of an electrical conductor comes in contact with the ground (i.e., Earth) itself, lake / sea or objects located on or connected to these ground planes. The term back-fed as described in [1] is used when the object touching the ground plane in a faulted object is located on the downstream side of the supply and the fault is fed back through a distribution transformer.

With a focus on the primary and secondary power distribution system, the scope of the study is to determine a *signature* of the electric measurements on the secondary side of a distribution transformer. This is desired when the fault location is on the primary distribution network system. Thus, the scope of the study is to implement elements of the Smart Grid [2-3] for the detection of back-fed ground faults.

In this thesis, a European designed distribution system is considered. Specifically, a design common in Norway is used as the base design, the test bed for examples, and focus of analysis. Many of the concepts shown in the thesis may be applied to distribution system designs in North America and elsewhere, but the thesis itself uses the Norwegian system as a basis. The author had access to actual data from an operative distribution system in Norway, and these data were used wherever possible.

1.2 Background

Certain fault situations occurring in the three phase primary distribution system are more difficult to detect and isolate. In more than two decades different research and studies have been done on the matter, but there is still no definitive reliable solution, used by electric utilities, to detect a single broken conductor in the distribution system with or without ground connection on the downstream side of the fault location. The fault situation with a back-fed ground fault or a downed conductor is a tremendous safety issue for the general public since the potential impact could in worst case have a lethal outcome as discussed in [4].

The electric power utilities and the distribution system suppliers have tried to come up with various solutions for detecting back-fed earth faults. Quite a few different solutions have been tested without obtaining a reliable system. An emerging Smart Grid infrastructure utilized through the advanced metering system gives new and intelligent possibilities and access to so-called 'big data' deeper down into the electric distribution system than before. The federal government of Norway has issued a regulation [5] that requires all Norwegian electric utilities to install advanced metering system (AMS) within Jan 1st 2019. One outcome of this regulation is that all distribution transformers in the primary distribution system of Norway will contain a smart meter that is connected to an advanced metering infrastructure. This in addition to smart meters located at the point of end use at the customers. Each electric utility will acquire a central system for data collection and monitoring data readings from all customers in the secondary distribution system in addition to the previous mentioned distribution transformers.

1.3 Distribution power system / Norwegian power system design

The distribution power system is typically defined from the distribution substation transformer fed from one or more lines in the subtransmission system. Facts and figures about the European power distribution can be found in [6]. Comparison between the North American and European distribution systems as well as an overview of the European distribution system are presented and explained in references [6-14].

A main feeder out from a distribution substation bus is equipped with one or two circuit breakers depending on the engineering design of the bus system, instrument transformers protection relay and control equipment. A typical feeder design with main components is shown in Figure 1.1. The feeder relay consist of a protection scheme utilizing

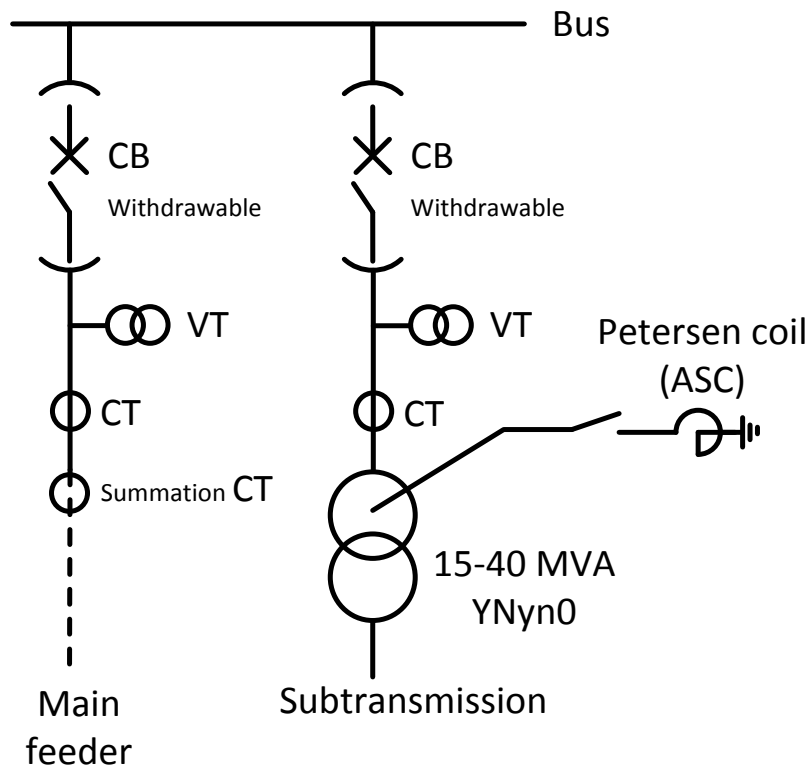

Figure 1.1 Distribution Substation Feeder Design

overcurrent and earth-fault detection capabilities utilizing a current transformer in each phase and a summation current transformer on the outgoing cable. In cases where a directional overcurrent protection is necessary the feeder is equipped with a voltage transformer. Where distributed generation resources are present and connected to the feeder the voltage transformer is also used for synchronization and phase-sequence monitoring functionality.

Focus is now turned to power distribution systems in Norway. The reason for this focus is that the author is working for a Norwegian power company, and data for test beds and components were readily available for the Norwegian system. In addition, there has been special emphasis in Norway to implement selected objectives of the smart grid initiative. The distribution system in Norway can be divided in two parts; the primary and the secondary electric power system. Reference [15] gives a brief overview of the transmission and distribution system of Norway. The primary system is often referred to as the medium-voltage (MV) system and the secondary as the low-voltage (LV) system. Both are operated as radial systems with feeders and laterals using mainly three phase configuration. In populated areas the primary system is built as a meshed system as shown in Figure 1.2. Figure 1.3 shows a typical rural radial distribution system. The meshed rural system is separated with overhead disconnect switches (with or without load breaking capability) in order to operate it as radial system. Important connections or critical loads will often contain remotely controlled functionality (from a SCADA system in a centralized utility control center) so that an area or a load can be supplied from a different feeder or distribution substation.

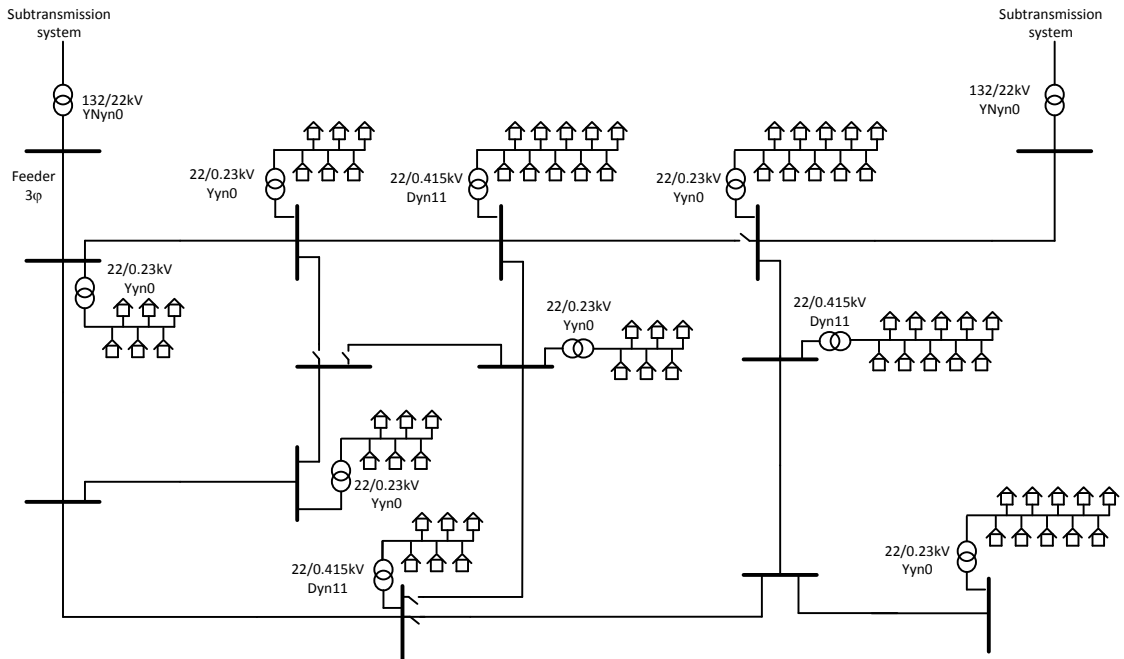

Figure 1.2 Sample Norwegian Distribution System in Urban Area

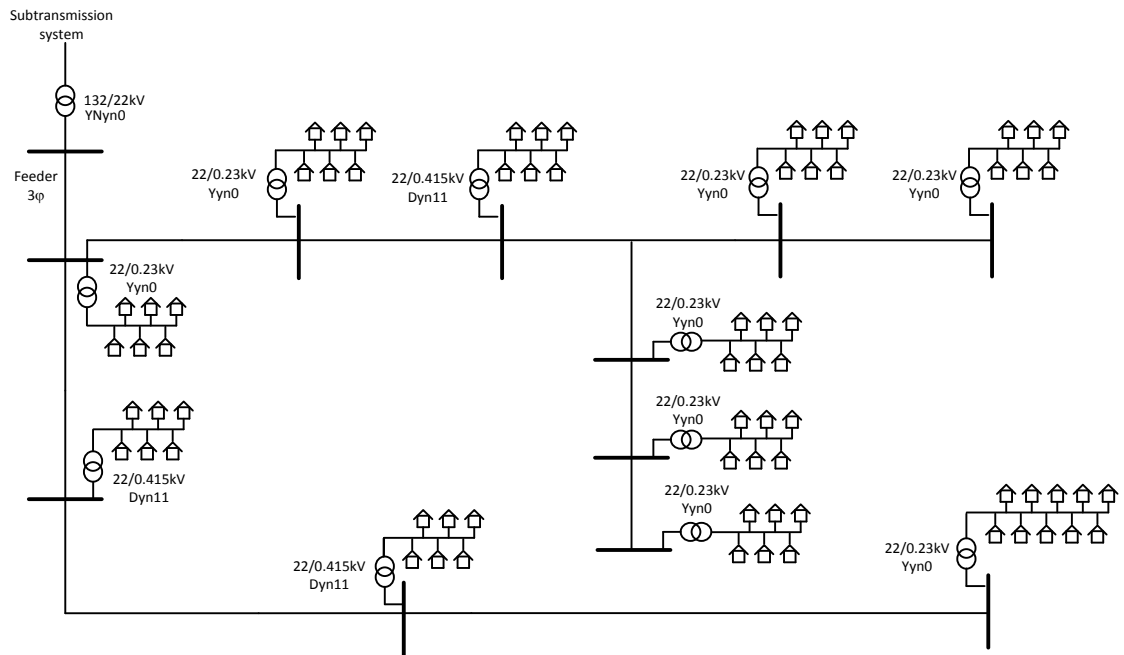

Figure 1.3 Sample Norwegian Distribution System in Rural Area

The primary distributions system utilizes a rated voltage level of 24 kV in mixed overhead and cable systems and 12 kV in cable systems in the urban areas. The 24 kV distribution system is operated at a voltage level of either 22 or 23 kV and is mainly configured either as a resonant compensated system design using a Peterson coil or an isolated system with an open neutral. A voltage level of 10.0 to 10.3 kV is normally the operating voltage of the urban type system mainly using a configuration with an isolated neutral system

The secondary distribution power system is mainly based on a 230 V supply voltage. Most residential loads have 3 phase system to the supply end in the secondary distribution. The use of 3 phase system versus single phase system is more loss efficient and can utilize larger size transformers.

Compared to the typical North American distribution system the voltage is two times higher giving the longer reach with the same voltage drop. This way there are also a higher number of customers per secondary distribution transformer. The balancing of the load is usually done with a busbar connecting the outgoing circuits at the consumer end.

The international standard IEC-60364 [16] designates and divides the grounding systems for low-voltage systems into three main configurations shown in Figure 1.4. The first letter in the two-letter code describes whether the equipment has a point connected to ground or not at the supply end. The letter "T" comes from the Latin word "Terra" which translates to ground or earth. An isolated supply system is indicated with an "I". As for the consumer end the grounding is indicated by the second letter. The letter "N" implies that the consumer equipment is connected to neutral that also often grounded at the supply side.

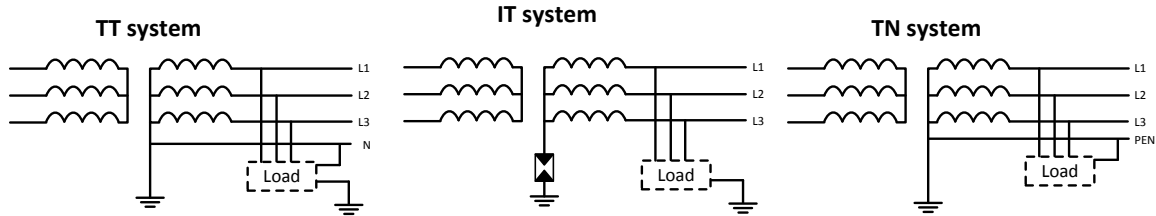

Figure 1.4 Secondary Distribution System Configurations

In an IT type of system the neutral connection in the distribution transformer is isolated using a protective gap and an insulation monitor device between the phase and ground. The voltage level is 230 V between each phase and there is no neutral conductor directly from the transformer to the load. The load is connected between two of the phases. Norway and Albania are among the only European countries still using the IT system configuration for public systems.

A TT-system network has solidly grounded neutral connection in the distribution transformer and is similar to the IT-system. According to [17] it is a system that is easiest to build and most widely used worldwide.

The TN system network also has a solidly grounded neutral where the neutral connection (called Protective Earth Neutral) from the distribution transformer neutral is brought to the load. Different combinations of the TN system named TN-C, TN-S and TN-C-S exist, where the PEN partially or fully is divided into separate conductors; neutral (N) and protective earth (PE). The TN system has a voltage of 400 V between phases and 230 V between phase and neutral or ground depending on the configuration. Typical residential load is connected between phase and neutral to utilize the 230 V voltage. The

TN-system is widely used in the distribution power systems throughout Europe and is also the system used in new residential areas build in Norway.

The distribution system is designed with mainly 3-phase distribution transformers feeding the customers connected to the radial secondary distribution system. Although there are some older type pole transformers, the major type distribution transformers are compact secondary substations. These compact substations contain separated medium- and low-voltage room for switchgear as well as a distribution transformer. A typical substation is equipped with a meter for the power supplied on the transformer secondary side. As mentioned in the previous section, a new smart two-way meter is to be installed as a part of the new regulations in Norway [5]. A typical connection scheme for a compact secondary substation transformer is shown in Figure 1.5.

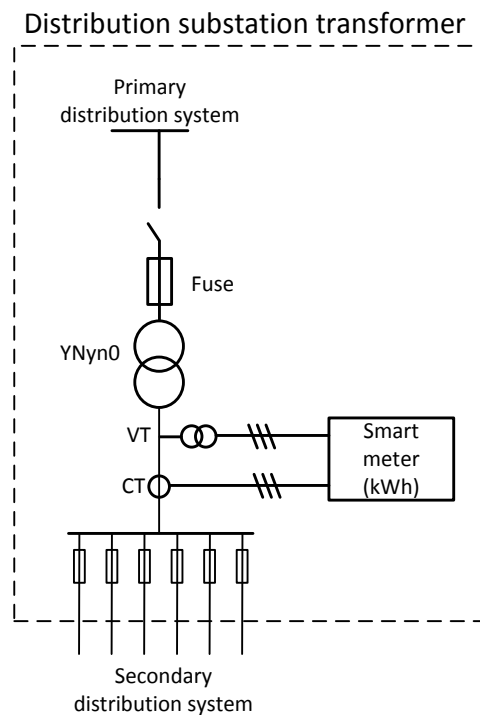

Figure 1.5 Typical Smart Meter Scheme at Secondary Compact Substation.

The HV side of the transformer is normally equipped with a switch and a fuse and the LV side contains a current transformer (CT) and a voltage transformer (VT) where the meter and future smart meter is connected. The supplying circuits on the LV side towards the customers are equipped with fuses for each circuit having a time-inverse characteristic. Depending on the type of distribution substation connection the HV side will contain one or more incoming or outgoing bays containing a switch for the overhead line or cable. New distribution transformers with its switchgear and auxiliary equipment are received from the manufacturer in a dedicated enclosure.

1.4 Compensated distribution systems and Petersen coils

A typical primary distribution network in Norway is either isolated or compensated with an arc suppression coil device. The use of compensated distribution system is widely used in both Europe and Asia. The arc suppression coil, widely known as the Petersen coil, was first introduced by Prof. W. Petersen of Darmstadt, Germany [18] in 1916 in Germany. In essence, these coils are reactors used to ground the neutral of three phase systems. The addition of reactance suppresses ground fault currents.

The use of the Petersen coil in a North American distribution system is explained and described in [19] from 1922 and an operating performance experience from Alabama Power Company is described in [20] from 1923. The use of the Petersen coil in Great Britain is discussed in [21] from 1936, [22] from 1938 and [23] from 1944. Another reference [24] explains more detailed theory, operation, and tuning the Petersen coil. More recent references [25-28] present how the Peterson coils are presently designed and used

today. A recent implementation of a resonant distribution system using Petersen coils in parts of Spain is presented in reference [29].

In the Norwegian system discussed here, the Petersen coil is currently being used in the sub-transmission system and in the primary distribution power system and is the main component in a resonant grounded system. The coil is a single phase reactor connected to the neutral point of a transformer the inductance of the Petersen coil and the capacitance to ground for the distribution system makes a oscillating circuit. This circuit is tuned to the frequency of the system. When single line-to-ground fault with arcing occurs, the circuit helps the system to self-heal and clear the fault without and outage for the customer. The modern Peterson coil, often referred to as an Arc Suppression coil (ASC), is normally a plunger core reactor as explained in [30] where the current value of the coil is adjusted by changing the gap of the magnetic core. By doing this, the magnetic reluctance is altered and the reactance of the Petersen coil can be automatically adjusted according to the operation of the power system.

The background for the use of the Petersen coil is the occurrence of temporary ground faults with arcing in a distribution power system. In a normal operated distribution system without faults it is irrelevant what grounding method is used. It is when a fault occurs that the different type of grounding comes into place. When using a Peterson coil to compensate the power system, the coil is adjusted to a inductive value that will cancel out the capacitive reactance of the power system referenced to ground. In order to avoid high resonant current peaks due to untransposed system, a normal operation of the Peterson coil is adjusted to a inductive current value of 5-10% above the total capacitive current of the power system compensating. A diagram showing the distribution system

circuit with currents circulating during a single-fault to ground fault is shown in Figure 1.6. The capacitive current occurring during a single-line-to-ground fault is cancelled by the inductive current that the Peterson coil is adjusted to prior to the fault.

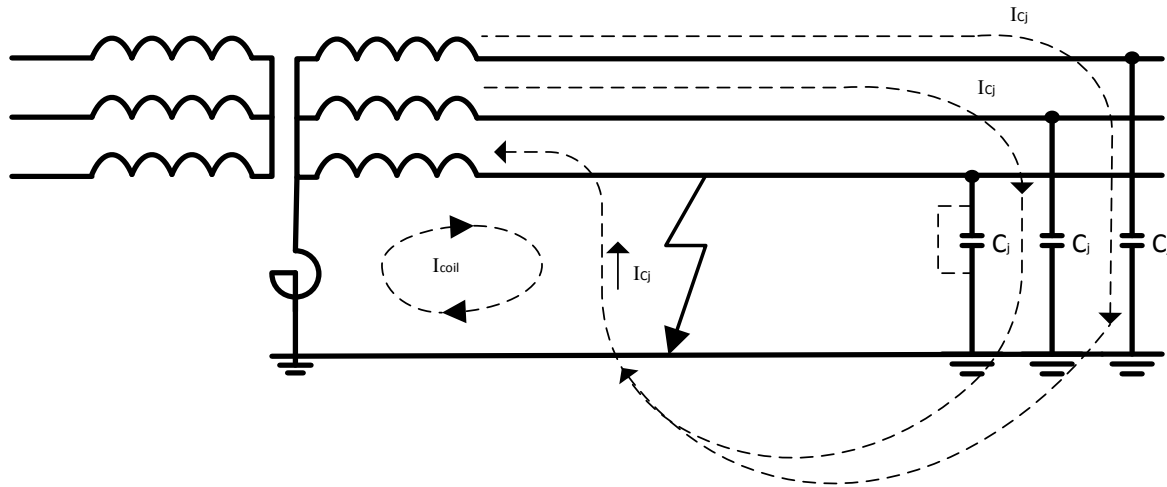

Figure 1.6 Compensated Distribution System with a Single Phase to Ground Fault

To maintain a high level of service for the supply to the customers the electric utility strives to have a best possible continuity of supply. A Petersen coil is according to [30] a "*key component of modern earth fault protection systems*" and the use can greatly reduce the impact of a temporary ground fault. The human safety perspective [31] is an important issue that is greatly improved by the Petersen coil. References [31, 32] also point out that use of it can prevent a repeating ground fault due to the slow voltage recovery of the faulted phase. According to [33], resonant grounding clears almost 60% of all ground faults in an overhead line system. Reference [27] presents how the continuity of supply has improved due to the use of Petersen coils in the distribution systems.

1.5 Broken and downed conductors

In a primary distribution system a broken or open conductor in a three phase system can occur due to a bad splice in a conductor, a tree that fall on one phase and break the conductor, a bad clamp that free the loop in a tower/pole or a blown fuse. A downed conductor is when a conductor breaks and touch the ground. In the case where the downstream side of the conductor (towards the customer side) touch the ground the fault is said to be a back-fed ground fault [1]. This is also illustrated in Figure 1.7 and 1.8. If the upstream side of the conductor touch the ground the fault could appear as a regular ground fault, although often with a high impedance to ground.

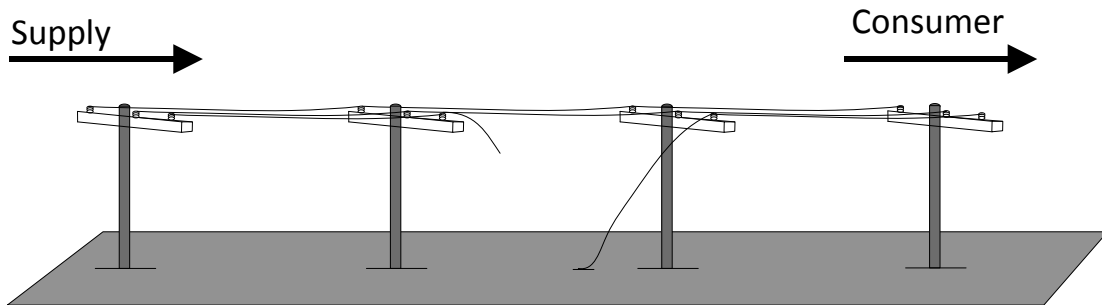

Figure 1.7 Downed Conductor/Back-Fed Ground Fault

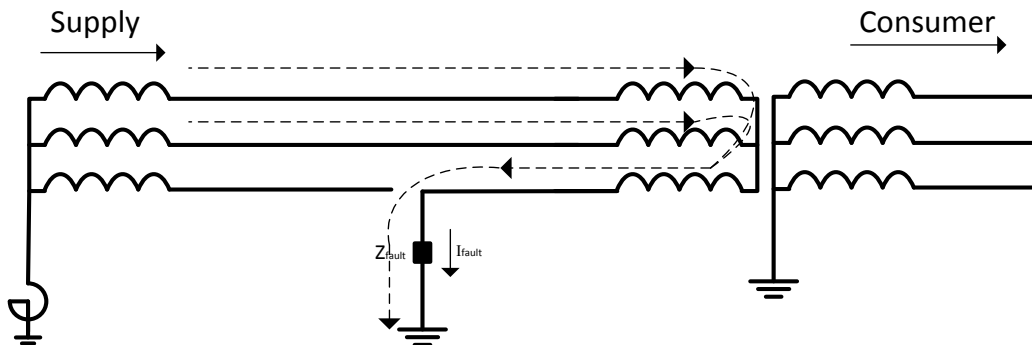

Figure 1.8 Electrical Representation of Back-Fed Ground Fault

As mentioned a broken or a downed conductor often appears as a high impedance fault (HIF) in the distribution system and due to the low fault currents is difficult to detect. As mentioned in [32] the HIFs have been a great challenge for the electric utilities for decades. Reference [34] states that generally 30-50 % of such HIFs are not detected by conventional protection systems. Lots of research has been done on the subject of broken and downed conductors, with suggested methods of detection [31-32, 34-37, 38-44]. Bjerkan, Høidalen and Hernes [35] present a fault indicator sensor method based on voltage measurements. The fault generated high frequency transient signal that occurs after a fault is proposed captured in [44] called the positional protection technique. A method using time shifting in the line currents is proposed by Pongthavornasawad and Rungseewijitprapa in [34]. Reference [37] presents a methodology using discrete wavelet transformations and neural networks.

A presentation of 11 different techniques to detect downed conductors in a distribution system is done in [38] from 2001. The known limitations are discussed, whereas the authors L. Li and M. Redfern [38] conclude that the challenge of detection still exists and must be further investigated in research and projects. They also mention that the introduction of microprocessor based systems in the monitoring and control in the power system plays an important role. A continuing progress in the communication system technologies for collecting and managing the 'big data' that becomes available could help give a robust and well-functioning solution. The latter is also the background and object of the work for this thesis where the aim is to use the new smart grid technology to help the detection of broken and downed conductors.

1.6 Open distribution system simulator (OpenDSS) analysis tool

OpenDSS is an open source computer program available on the internet [45] and is freeware for use by anyone. As explained in the reference guide for the program [46], the OpenDSS analysis tool is a comprehensive tool mainly used for distribution system purposes. References [47-62] give a selection of projects where it is used towards the Smart Grid development as well as the where distributed generation (DG) is present on distribution system feeders. OpenDSS is an open source software that can be expanded with user written code (DLLs) and is based on a text editor user interface. The software has a COM interface that enables the advanced users to use other software and programs to run and design the different features and modes. According to [46] Mathworks MATLAB, MS Office using VBA, Python and C# are among the software and languages that can and are being used. The software is supported and developed by Electric Power Research Institute (EPRI).

The main modes of simulation for the current version of OpenDSS contains of power flow, fault studies, harmonic flow analysis, dynamic simulation, load parametric variation and geomagnetically induced current (GIC) analysis. The power flow and fault study modes that are used in this study is explained thoroughly in the next main chapter.

OpenDSS uses nodal admittance equations to represent its circuits. An distribution system model in OpenDSS is build up with the use of buses, lines, transformers and loads. A bus has a finite number (0, 1, 2, 3, ..., N) of nodes whereas each node represents an individual phase or neutral and ground. Node 0 of a bus is connected to referenced voltage point. The nodes are also terminating points for the lines and cables defined for each system. The bus has the voltage as the main electrical property and is referenced to

zero voltage (ground, or earth). An electrical element like a line or a transformer is given one or more terminals whereas each terminal can have one or more conductors connected. The concept of a terminal is that it has a disconnect switch and fuse curve. The terminal has one or more phases that are conductors that can transfer power or used for purposes like grounding or represent neutral.

OpenDSS differs between power conversion elements and power delivery elements. A power delivery element is a device that can transfer energy between two specified points, like a line or a transformer. Hence, a power delivery element can be defined by its impedance. The power conversion element converts the energy from one form to another and will usually contain only one terminal in a one line diagram. The typical non-linear elements are a load or a generator where OpenDSS treats these as a Norton equivalent with a constant impedance and an injection current.

An example with a simple circuit is shown in figures below. Figure 1.9 shows the single line diagram for the circuit.

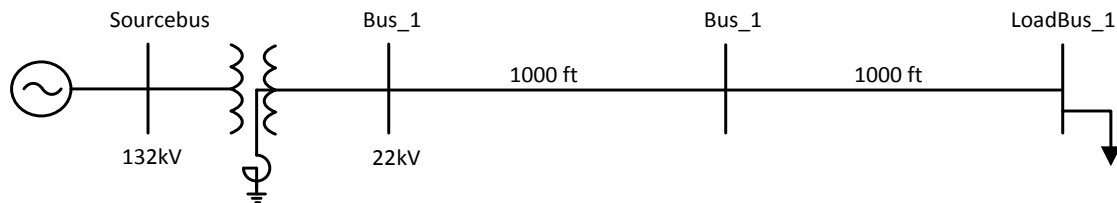

Figure 1.9 OpenDSS Sample Circuit

As a new circuit is augmented OpenDSS always creates a three phase voltage source called "Source" that is connected to a bus called "Sourcebus". The voltage source is a Thévenin equivalent (i.e. voltage source and impedance) having two terminals and multi phases. The base voltage of the source is in this example set to 132 kV. The circuit

contains a substation transformer that has a secondary voltage of 22 kV, two overhead power lines and a load of 1 MW connected in delta to represent a Dy MV/LV transformer. Figure 1.10 shows how OpenDSS makes the connection of the circuit elements

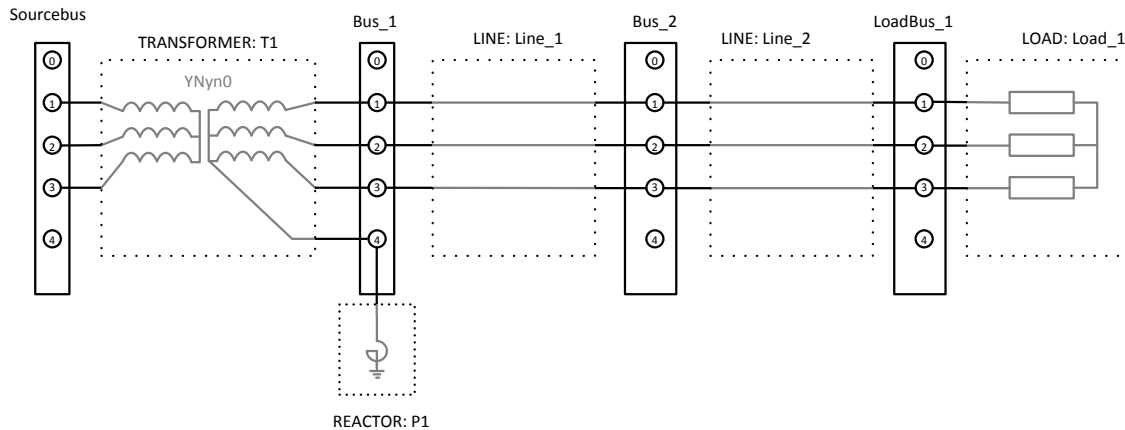

Figure 1.10 Circuit Elements Connections in Opendss Sample Circuit

Figure 1.11 shows the code used for the sample circuit. The code in OpenDSS is written as a normal one or more text files with the extension ".dss."

```

Clear

New Circuit.Thesis BasekV=132 p.u. =1.0 angle=0 frequency=50 phases=3

!! substation transformer
new transformer.T1 phases=3 winding=2
~ conns=(wye, wye) kvs=(132, 22) kvas=(25000, 25000) %loadloss=0.352 xhl=11.545
~ %Noloadloss=0.088
~ wdg=1 bus=sourcebus %r=0.175
~ wdg=2 bus=Bus_1.1.2.3.4 %r=0.175
! Peterson coil - 16A
New Reactor.P1 phases=1 bus1=Bus_1.4 bus2=Bus_1.0 kV=12.7 kvar=203.2

New LINE.Line_1 Bus1=Bus_1.1.2.3 Bus2=Bus_2.1.2.3 Length=1000
New LINE.Line_2 Bus1=Bus_2.1.2.3 Bus2=LoadBus_1.1.2.3 Length=1000
New LOAD.Load_1 Bus1=LoadBus_1.1.2.3 kW=1000 pf=0.95 conn=delta ! assume

```

```
Dy MV/LV transformer
Set voltagebases=[132,22]
calcV
solve
show voltages LN Nodes
show voltages LL Nodes
show voltages ! Sequence voltages
Show Currents residual=yes Elements
```

Figure 1.11 OpenDSS Code for Sample Circuit

1.7 Organization of this thesis

Chapter 1 has given an overview of a type of system that will be used for this thesis as well as an introduction to the approach and the tool being utilized. A thorough discussion of the distribution system, together with the modeling of its components, is given in Chapter 2. The concept of analysis is also presented in Chapter 2. Chapter 3 contains the simulation results from using the OpenDSS tool on the test-bed created. The chapter is divided into 5 different examples where the resultant simulation values are presented in tabular form and illustrated graphically. Algorithms to solve the objective of this thesis and an evaluation of a set of rules are also presented in Chapter 3. Chapter 4 makes some concluding remarks on the findings as well as recommendations for future work. The Appendix gives the relevant OpenDSS code used for the various simulated examples presented in Chapter 3.

CHAPTER 2

MODELING AND ANALYSIS OF DISTRIBUTION SYSTEMS

2.1 Primary distribution system components

To perform an analysis of a primary distribution system (i.e., the part of the distribution system on the high side of distribution transformers, sometimes referred to as ‘medium voltage’ circuits) the vital components of the power system need to be defined and modeled. In any kind of study of a distribution feeder or a distribution system the under steady-state operation under normal conditions is identified by first performing a power flow analysis. Depending on the type of research such a study can be done on one single feeder, all feeders out from a single substation or several substations that has a distribution system that can be interconnected. The major components of a primary distribution system model are:

- Source (to model supply system or the system equivalent)
- Substation transformer between subtransmission (high voltage - HV) and primary distribution (medium voltage – MV) level
- Reactor (ASC/Petersen coil) in given grounding systems
- Capacitor bank for voltage regulation
- Power lines or power cables (overhead lines, isolated lines, underground cables)
- Distribution transformer between primary distribution (MV) and secondary distribution (LV) level
- Load on either primary or secondary distribution system level.

Added up in series and/or in parallel, the components get connected and form a system that can be modeled either as a single-phase system, three-phase system or a mix of the two.

In North America, primary distribution systems are generally rated between 5 kV and 14.7 kV (three phase) and about 10 MVA. Higher voltages to 37.5 kV have also been used and proposed. For Europe the primary distribution systems, often referred to as ‘medium voltage’, are generally rated between 1 kV and 36 kV (three phase) with a capacity of about 50-60 MVA.

2.2 Secondary distribution system components

A secondary distribution system contains mainly the same components as the primary distribution system. Although often included or lumped together as a load in a primary distribution system model, the major components of a secondary distribution system are:

- Sources (to model supply system or the system equivalent)
- Distribution transformers between primary distribution (MV) and secondary distribution (LV) level
- Power lines or power cables (overhead lines, isolated lines, underground cables)
- Fuses
- Loads.

Analysis at this level is mainly done when planning new or additions to residential areas or in industrial distribution systems. Tasks performed are fuse analysis, short-

circuit analysis and voltage drop calculations in addition to a power flow analysis in order to engineer the correct ratings of components for the desired system.

In North America, secondary residential distribution circuits are generally rated 118 V single phase with 230 V also brought into most residential services according to [63]. The current rating varies with the level of service but 300 A service to one residence is common. In Europe, typical residential low-voltage systems are rated 230 V three phase voltage for IT/TT systems and 230 / 400 V for TN-systems. The current rating is normally around 63 A three phase in new residential services.

2.3 Transformer modeling

One of the main tasks for the specification of a transformer in a substation is to define the voltage ratings as well as the operating voltage and perform the voltage regulation of the distribution system feeders. The power transformer is designed and manufactured based on the international standards IEC 60076 [64] and IEEE C57.12.00 [65]. All power transformers are tested according to the standards and are issued with a test certificate. A test certificate contains the measured parameters that are the basis for the modeling of a transformer in any analysis tool.

A power transformer has two or more windings whereas the winding with the input or the supply side is named the primary winding. The other one or two windings are often referred to as secondary and tertiary winding. The secondary is usually the main output. A winding is connected in a specific manner based on preferred use and numbers of phases. There are several different ways of connecting the windings of a power transformer with wye-wye (also referred to as ‘star-star’) connections being the most common

for substation transformers between HV and MV in a resonant grounded subtransmission and distribution system. Using three-phase systems the main winding connections categories are:

- Delta (D,d)
- Star (Y,y)
- Interconnected star (Z,z).

The notation used for the transformers describes the vector group and contain capital letters for the higher voltage winding and lower-case letters for the lower voltage winding . It there is a neutral connection brought out this is denoted the letter n. An example of a preferred connection for a distribution transformer in a IT and TT type system is the Yyn0. This means that the transformer is connected in a star-star (Yy) whereas the neutral (n) for the LV side is brought out and there is no phase shift (0) between MV and LV side. If the neutral is brought out on both windings the same transformer would have the notation YNyn0.

Other common used distribution transformer connections are the Dyn11, Dyn5 and the Dd0. The first two are delta-star connected with the lower voltage neutral brought out and a phase displacement of 30° lead and 150° lag, respectively. Where there are a mix of existing 230 V and new 400 V secondary distribution systems a distribution transformer has both Dyn11 and Dd0 vector group. The 400 V system utilize the Dyn11 and the 230V the Dd0. A Dyn11 or Dyn5 is the most common three phase distribution transformer in a TN type system, although it can be utilized in IT and TT as well. A list of various distribution transformers and their vector groups are shown in Table 2.1.

Table 2.1 Distribution Transformers and Vector Groups

Vector group	Phase shift (MV-LV)	Description	Common grounding methods
YNyn0	0°	Star-Star connected windings (Yy) Neutral is brought out on both windings (Nn)	IT, TT
Dyn11	30° lead	Delta-Star connected windings (Dy) Neutral is brought out on secondary side only (n)	TN-C, TN-S, TN-C-S, TT, IT
Dyn5	150° lag	Delta-Star connected windings (Dy) Neutral is brought out on secondary side only (n)	TN-C, TN-S, TN-C-S
Dd0	0°	Delta-Delta connected windings (Dd). No neutral available	IT, TT
ZNyn11	30° lead	ZigZag-Wye connected windings (Zy) Neutral is brought out on both windings (Nn)	IT, TT, TN-C, TN-S, TN-C-S
YNd1	30° lag	Star-Delta connected windings (Yd) Neutral is brought out on primary side only (N)	IT, TT, TN-C, TN-S, TN-C-S
YNd11	30° lead	Star-Delta connected windings (Yd) Neutral is brought out on primary side only (N)	IT, TT, TN-C, TN-S, TN-C-S
YNd5	150° lag	Star-Delta connected windings (Yd) Neutral is brought out on primary side only (N)	IT, TT, TN-C, TN-S, TN-C-S

The connection diagram and hence the vector group for Yyn0, Dyn11, Dyn5 and Dd0 is shown in Figure 2.1. These are included in the test-bed used in the simulation. The connection of the distribution transformers are referred to as vector group which gives the phase displacement between the windings of the transformer.

The digits in the denotation for a transformer is related to the clock notation whereas the HV side is the reference and set equal to the time of 12. Every hour then represents a phase shift of 30 degrees, giving 1 = 30°, 2=60°, 5= 150°, 11=330° and 12=360° or 0°. Since the phase rotation is counterclockwise, a transformer with Dyn11 configuration would have the LV side lead the HV side by 30° (or lag by 330°). In a regular radial secondary feeder the phase shift is not important. It is when transformers are operated in parallel or in a meshed system that it is crucial to take into account the phase shift.

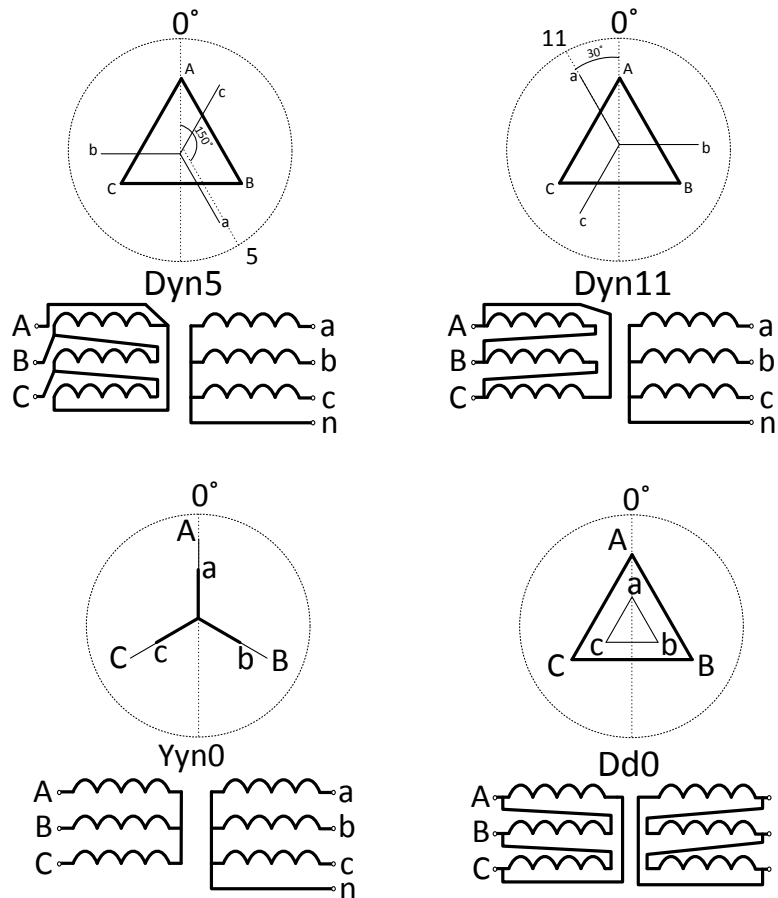

Figure 2.1 Transformer Vector Group Connection Dyn11, Dyn5, Yyn0 and Dd0

The transformer will have one or more phases per winding, usually equal number of phase for each set of high and lower voltage windings. Every winding will have a set of rated values and parameters which are voltage, kVA, winding resistance, reactance between windings, regulating taps, no load loss and load losses. Data for these values are normally found from test certificates and is unique for every transformer. A certificate for a 22/0.415 kV three phase distribution transformer for a TN type system is shown in Figure 2.2. Excerpt from a test certificate for a substation power transformer is shown in Figure 2.3.

MØRE TRAFØ	Obj. nr.	L. NR.	KVA	PER.	OMSETNING, VOLT	
	248700		50	50	22000+2X 2,5X-4X 2,5X	415
KUNDE			FABR. NR.		ÅR	LEVERINGSDATO
Vest-Agder Energi Nett			9905557		1999	OTKH 3525 25. 11. 99
FASTE DATA			VARIABLE DATA			
TOTAL VEKT	470	KG	OMSETNING, VOLT	22000/ 415		
OLJEVEKT	161	KG	NORMALSTR. AMP.	1, 312/ 69, 56		
TOTAL HØYDE	1155	mm	PO WATT	135		
TOTAL BREDDDE	6251	mm	PK 75°C WATT	1074		
TOTAL LENGDE	900	mm	Uk %	4, 25		
			Ur %	2, 15		
TRANSP. HJUL	<input type="checkbox"/>	TØRKEAPP.	Ro m OHM	74, 057		
GASSVAKT	<input type="checkbox"/>	MALT	Xo m OHM	101, 022		
TERMOMETER	<input type="checkbox"/>	VARMFØRZINKET	KOBLING OG GRUPPE	Dyn11		
OLJEMERKE	NYNÆS 10X		HS gjennomføring	36		

Figure 2.2 Sample Distribution Transformer Certificate Showing Test Results [66]

Depending on the connecting configuration of the transformer used in analysis the neutral resistance and reactance to ground must be chosen. For a Yyn0 configuration where the neutral is not used (i.e., open neutral) OpenDSS use a negative number (-1) as default. In cases where the neutral is utilized it must be connected in a carefully manner. OpenDSS connect the neutral by default to node 0 that is grounded. For the neutral to be used in a resonant grounded system the neutral must be set to be floating and then con-

nected to the grounding device. The OpenDSS code for a three phase winding would in that case would look like "Bus=Bus1.1.2.3.4", where numbers 1-3 is phase 1, 2, 3 and the notation '4' is the neutral.

ELETTROMECCANICA		TEST REPORT					
TIRONI		Power Transformer					
		with coolers in separate cooler's bank					

	at T _{med} °C	at 75°C				
Corrected Losses	(W)	(W)				
Losses referred at In	93.052					
Ohmic Losses at In - Primary winding	47.180	54.676	Full	Warranteed	Tolerances	Valore limite
Ohmic Losses at In - Secondary Winding	39.058	45.263	Uncertain	Value		
Stray Losses	6.814	5.880	%	(W)	(%)	(W)
HV-LV Load Losses at 75°C and In		105.819	1,5	108.000	10,0%	118.800
						OK

	at T _{med} °C	at 75°C					
Impedance Voltage	(V)	(V)	(%)				
Impedance Voltage at In	12.205			Full	Warranteed	Tolerances	Valore limite
Watt Component Vcc at In	400	455		Uncertain	Value		Inf
VA component of Vcc at In	12.199	12.199		%	(%)	(%)	Sup
HV-LV Impedance Voltage at 75°C and In		12.207	11,36	0,7	12,00	7,5%	11,10
							12,90

Transformation ratio	V/V	132000 +8x1911 -8x1911 / 23000	
Vector Group		YN yn0	
Primary winding			
HV Rated Power		25000 kVA	25000 kVA
Max Ambient Temperature		40 °C	40 °C
HV Max Rated Power		25000 kVA	25000 kVA
Max Ambient Temperature for max Power		40 °C	40 °C
HV Rated Voltage		132000 V	107500 V
HV Rated Current		109,3 A	134 A
HV Max Rated Current		109,3 A	134 A
step +		8	8
step -		8	8
Step Amplitude +		1911 V	1911 V
Step Amplitude -		1911 V	1911 V
Tap Changer		On-Load Tap Changer (OLTC)	
HV Winding Connection		Star with neutral	
HV Insulation Class		145 kV	
HV Test Level at rated frequency		275 kV	
Basic Impulse Level (Bil) LV phase		650 kV	
Basic Impulse Level (Bil) HV phase		650,0 kV	
Basic Impulse Level (Bil) HV neutral		650 kV	

Figure 2.3 Excerpt from Test Report for a 25 MVA Substation Transformer [66]

2.4 Peterson coil modeling

The Petersen coil/ASC is a vital component in the resonant grounded distribution system. In a substation the coil is connected to the neutral of the secondary winding of the power transformer often through a switch. If protection of the Petersen coil is desired a single-pole circuit breaker is also added. The Petersen coil is a shunt device with a variable inductance that together with the capacitance to ground for the distribution system it is connected to form an oscillating circuit. This single phase device can be modeled as a reactor. The parameters for the coil are often given in amperes. When placing a Petersen coil in a power system the utility distribution planners find the capacitive current to ground that the distribution power system contains and the adjusting for future expansion decide on size of coil.

A typical Petersen coil for a 22kV distribution system will have an inductive current range of 16-160 A and a rated voltage of 12.7 kV phase to ground. This gives a maximum reactance of 2032 kVAr rating for the coil. The current range of 16-160 A gives the adjustable range that the coil can operate within. In the substation the Petersen coil is equipped with an automatic regulator that can sense the change of operating in the distribution system. If a part of the system is disconnected the inductive current of the coil will automatically be changed by changing the magnetic reluctance of the coil to meet the new capacitance to ground value of the system. As mentioned in the previous section on transformers it is utterly important how that the neutral of the transformer is modeled correctly in order. This so that the reactor modeled and connected to the transformer can be utilized correctly. In Open DSS the reactor object is implemented as a constant impedance element. The reactor object in OpenDSS can have multiple phases, although the

Petersen coil is a single-phase device. Parameters that are used to model a Petersen coil are rated line-to-ground voltage in kV and total reactive power of coil in kVAr. The data used for modeling can be found from a test certificate. An excerpt from a test certificate is shown in Figure 2.4

TEST CERTIFICATE Routine Tests				1/1						
Test object :				Arc Suppression Coil						
Type :				ENK 20/160/2000						
1. Measurement of winding resistance										
Measurement			Calculation							
Terminal	t ₁ [°C]	R ₁ [mOhm]	T [°C]	t _r [°C]	c ₁	R _{dc} [mOhm]				
1.1 -1.2	16.5	699.4	235	75	1.23260	862.1				
2. Measurement of current and of no-load voltage of the auxiliary and secondary windings										
Calculation to rated voltage				U _r = 22000 /√3 = 12702 V (50 Hz)						
	Main winding	Secondary winding	Auxiliary winding	Current transformer	Potentiometer	Potentiometer				
Terminal	1.1 -1.2	X8.1-X8.2	X6.3-X6.4	X6.1-X6.2	X5.1-X5.3	X5.4-X5.6				
Position	I [A]	U [V]	U [V]	I [A]	R [Ohm]	R [Ohm]				
1	16.0	464.3	105.7		106	21.4				
2	20.0	467.5	106.5		121	24.4				
3	40.0	478.7	109.0		226	45.6				
4	60.0	483.4	108.7		332	66.4				
5	80.0	486.9	107.6		419	83.7				
6	100.0	491.9	108.1		493	98.9				
7	120.1	499.1	110.1		562	112.7				
8	140.0	508.4	113.4		636	127.5				
9	159.9	518.2	117.4	5.015	735	147.2				
3. Measurement of current and loss at rated voltage										
f = 50 Hz				t ₂ = 19 °C						
I _r [A]	read.	c	U [V]	read.	c	I [A]	read.	c	P [W]	Δ I _r [%]
16	63.60	200	12720.0	0.0781	200	15.61	0.131	40000	5248	-2.55
160	63.54	200	12708.0	0.8055	200	161.10	0.819	40000	32760	0.64
						I _r =			P _{r2} =	32314
								bei 75 °C: P _{dc} =	22069	
								bei 75 °C: P _r =	36301	

Figure 2.4 Excerpt From Test Certificate for Petersen Coil /ASC [66]

2.5 Load modeling

The complex power load in a system to be analyzed is normally measured by metering at every substation transformer, every distribution transformer and at the customer by the electric utility company supplying and operating the distribution system. Metering can be either done by a smart meter in an advanced metering system or manually by either the individual customers or the utility.

A distribution transformer generally supplies one or more customer depending on installed capacity and type of load (i.e. residential or industrial). As mentioned in section regarding transformers, three-phase devices are used. Hence, the load is also three-phase and can be configured either as delta or wye connected power. In Europe larger three-phase transformers between 315-1000 kVA are used to supply up to about 20-40 customers in urban areas, whereas in North America the corresponding numbers are 50-150 kVA and 2-4 customers.

A customer relationship management (CRM) system can be the basis for the load calculation where the maximum demand per customer can be obtained. To get the annual coincident peak demand for a distribution transformer or a larger part of a distribution system estimation based on formulas like the "Velder's formula" which is presented and explained in [66]. The complex power is either given as active (kW) and reactive (kVAr) power, kW and power factor (PF) or apparent power (kVA) and PF.

2.6 Line modeling

Since the distribution system usually contains lines with short lengths the "pi" line model is used for modeling the line object. There are mainly two ways to go about get-

ting the impedances used for modeling overhead lines and underground cables:

- 1) Symmetrical component values for R , X and C either as regular values or by matrix values
- 2) Use geometric approach to derive line impedance for a specific line and tower design.

OpenDSS also allow using a default line object without having to specify the symmetrical components. The sample circuit shown in the previous chapter is using this default line object that is a 1000 ft overhead line with a 336 MCM ACSR conductor on a 8-ft crossarm.

In addition to the R , X and C values for the line there are a few other parameters that need to and can be obtained for each line. That is length, number of phases/conductors, connected buses and units. Carson earth return resistance (R_g) and reactance (X_g) as well as earth resistivity (Rho) if earth return correction factor computation is needed.

2.7 Analyzing broken conductors and back-fed ground fault

The objective with this thesis is to find a *signature* of the situation that occurs when a broken and/or a back-fed ground fault is present in a primary distribution system. When implementing the modeling from the previous sections in a simulation current and voltages from nodes the primary and the secondary distribution are available. Since this thesis is focusing on using the available data from a smart grid technology point of view, it is the measurements from the LV side of a distribution transformer that mainly will be

evaluated. These are also the measurements that can easily be available from the smart meter collection system.

Since the distribution system contains transformers with different vector groups and connections all the main types need to be evaluated and included in the model. The current present in a transformer will vary quite a bit with load variations and fault situations with various fault impedances. Due to this fact the voltage measurements are considered to be the more reliable and more useful for an analysis. The use of a voltage based method is also discussed in [35].

2.8 Analyzing single line-ground faults in distribution systems

To get a good and reliable *signature* and algorithm for detecting a broken conductor and a back-fed ground fault other fault situations like a single line-to-ground faults need to be considered and evaluated. Different abnormal situations that occur can give more or less equal results. Single line-to-ground fault will be simulated and evaluated for both the primary and the secondary distribution system. Both line-to-neutral and line-to-line positive sequence network voltages will be used for comparison to increase the reliability of the detection algorithm.

CHAPTER 3
EXAMPLES OF THE FAULT DETECTION METHODOLOGY
AND EVALUATION OF THE METHOD

3.1 Distribution system sample case / test bed

In order to investigate and evaluate the behavior of a distribution system during various fault conditions a sample system or a test bed has been developed. The single line diagram schematic is shown in Figure 3.1 where one feeder out from a subtransmission substation is present.

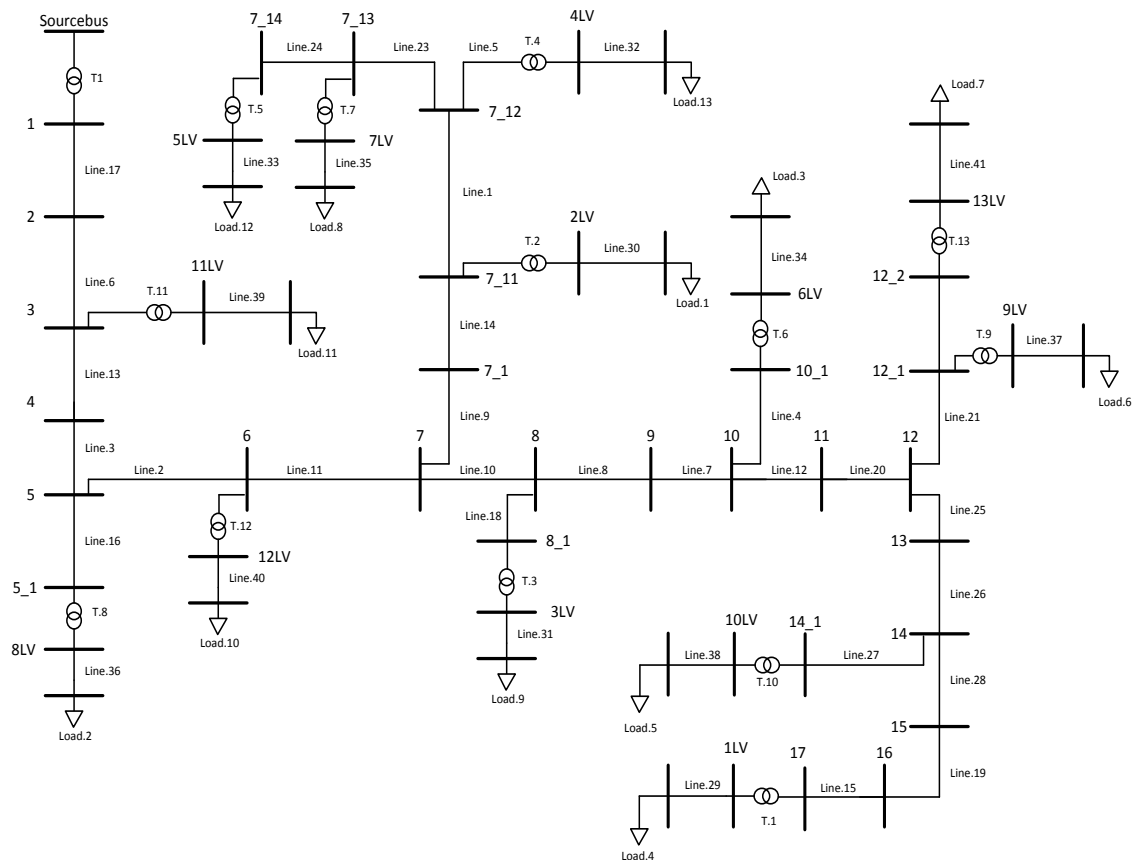

Figure 3.1 Distribution System 22 kV Feeder Test Bed

In the test bed both the substation transformer (labeled T1) and the substation busbar (labeled bus 1) is included. The substation transformer is a 132/22kV 25 MVA transformer with a Yyn0 vector group. A total number of 13 distribution transformers make up the mixed overhead line and underground cabled MV three phase distribution system. The test bed shown in Fig. 3.1 is the test bed used in all the examples shown in this thesis. The system is based on an actual distribution system taken from the Network Information System (NIS) of Agder Energi Nett AS (AEN), a Norwegian electric utility. AEN is part of the third largest energy parent company of Agder Energi located in the city of Kristiansand,

Norway. Kristiansand is a coastal city and according to [68] the administrative, business and cultural capital of Southern Norway. The region with its surrounding municipalities has a population of 120,000 people and is shown in



Figure 3.2 Map of Northern Europe Taken from [69]

Figure 3.2. All line and cable impedances and lengths, transformer and load data is provided from AEN. The three phase feeder is a strictly radial system from a rural forested area outside the city of Kristiansand with no return paths or connections from other sub-

stations or other feeders from the same substation. Distributed Energy Resources (DER) are not present on this feeder, hence not taken into account for in the model used in this thesis.

The distribution transformers present in the feeder are modeled with various types of vector group. An overview of the transformers used in the model is shown in Table 3.1. Four different types of vector group are modeled and analyzed. Common vector groups like the Yd1, Yd11 or Yd5 is not included as they are usually utilized for small DER generation units. Also the results for the wye-delta connection group will show similar results to that of the delta-wye.

Table 3.1 Distribution Transformers

Name	T.1	T.2	T.3	T.4	T.5	T.6	T.7	T.8	T.9	T.10	T.11	T.12
Vector-group	Yyn0	Yyn0	Yyn0	Yyn0	Yyn0	Yyn0	Yyn0	Yyn0	Dd0	Yyn0	Dd0	Dyn11
Type	TT	TT	TT	IT	IT	IT	IT	IT	IT	TT	IT	TN

As for the distribution transformers built for new and additions of present primary distribution systems, the common standard vector group connected transformers in the Norwegian distribution system are usually chosen as follows:

- Yyn0 – for 240 V rated systems with IT or TT configuration
- Dyn11 or Dyn5 – for new 415 V rated systems with TN-C and TN-C-S configuration
- Dyn11(Dd0) – for mixed 240/415 V rated systems with reconfigurable secondary winding with IT/TT (230V) and TN-C (415V) configuration

- Dyn11/yn11 – for mixed 240/415 V rated systems with two secondary windings to a IT/TT (230V) and TN-C (415V) configuration.

As mentioned in Chapter 1 the aim of the study in this thesis is to reveal a *signature* of the behavior of a distribution system during broken and downed conductor. The subject to be evaluated is the available measurements in the smart grid technology of the secondary side of a distribution transformer in primary distribution feeders. In order to analyze and evaluate, a set of examples are defined for various cases. These are shown in Table 3.2. Example 1 and 2 contain different cases in order to see the influence that the position of the fault has on the outcome.

Table 3.2 A Set of Examples Used for Simulation and Evaluation

Example	Name	Complementary comments
1	Broken conductor in primary distribution system	Model a split line where none of broken conductor ends touch the ground. Using two cases: 1) Broken conductor close to supply and 2) Broken conductor towards the end of feeder
2	Back-fed ground fault (downed conductor) in primary distribution system	Model a split line where the downstream side of broken conductor connect directly to ground using three cases: 1) Downed conductor close to supply 2) Downed conductor towards end of feeder 3) Downed conductor on radial line near transformers
3	Single line-to-ground fault in primary distribution system	Model a direct line-to-ground fault in on one of phases of a selected bus in the MV system
4	Single line-to-ground fault in secondary distribution system	Model a direct line-to-ground fault in on one of phases of a selected bus in the LV system for 4 types of vector groups and connection type systems (Yyn0 IT, Yyn0 TT, Dyn11 and Dd0)
5	Double line-to-ground fault in primary distribution system	Model a direct double line-to-ground fault in on oneof phases of a selected bus in the LV system for 4 types of vector groups and connection type systems (Yyn0 IT, Yyn0 TT, Dyn11 and Dd0)

As in all kind of fault studies, a regular power flow study is used as the base case and the base case is calculated before any fault is applied to the modeled circuit. Results

from a regular power flow analysis for the test bed gave the results as shown in Table 3.1. The voltages are given in per unit quantities (p.u.) and only a selection of busbar voltages for comparison are included.

Table 3.3 Test-Bed Results for Voltages [P.U.] at Selected Buses with Normal Operation

	Bus 1	Bus 17	Bus 1LV	Bus 14_1	Bus 10LV	Bus 12_1	Bus 9LV	Bus 12_2	Bus 13LV
V1n[p.u.]	1.00 ∠-0.1°	1.00 ∠-0.2°	1.04 ∠-0.5°	1.00 ∠-0.2°	0.99 ∠-0.8°	1.00 ∠-0.2°	1.04 ∠-0.8°	1.00 ∠-0.2°	1.00 ∠ 29.5°
V2n[p.u.]	1.00∠- 120.1°	1.00∠- 120.2°	1.04∠- 120.5°	1.00∠- 120.2°	0.99∠- 120.8°	1.00∠- 120.2°	1.04 ∠-120.8°	1.00∠- 120.2°	1.00∠- 90.5°
V3n[p.u.]	1.00∠ 119.9°	1.00∠ 119.8°	1.04∠ 119.5°	1.00∠ 119.8°	0.99∠ 119.2°	1.00∠ 119.8°	1.04∠ 119.2°	1.00∠ 119.8°	1.00∠ 149.5°
Vnn[p.u.]	0	0	0	-	0	0	0	0	0
V12[p.u.]	1.00 ∠ 29.9°	1.00 ∠ 29.8°	1.04 ∠ 29.5°	1.00 ∠ 29.8°	0.99 ∠ 29.2°	1.00 ∠ 29.8°	1.04 ∠ 29.2°	1.00 ∠ 29.8°	1.00 ∠ 59.5°
V23[p.u.]	1.00∠- 90.1°	1.00∠- 90.2°	1.04∠- 90.5°	1.00∠- 90.2°	0.99∠- 90.8°	1.00∠- 90.2°	1.04∠- 90.8°	1.00∠- 90.2°	1.00∠- 60.5°
V31[p.u.]	1.00∠ 149.9°	1.00∠ 149.8°	1.04∠ 149.8°	1.00∠ 149.8°	0.99∠ 149.2°	1.00∠ 149.8°	1.04∠ 149.2°	1.00∠ 149.8°	1.00∠ 189.5°
Trans- former			Yyn0 / TT		Dd0 / IT		Yyn0 / IT		Dyn11 / TN

3.2 Example 1 – Broken conductor primary distribution system

A broken conductor that does not contact ground (i.e. earth) is considered for two separate phases only. The model chosen for the simulation uses symmetrical components for the line and cable impedances. Hence, mutual coupling is disregarded. Due to this, only one phase has been considered for further analysis, but two separate faulted phases are included to show in the results. This example as well as all the other examples shown here are for the test bed shown in Figure 3.1.

Case 1 – Broken conductor location at beginning of feeder

To simulate a broken conductor the beginning of the distribution feeder is done by opening the conductor in a phase using the OpenDSS command "OPEN LINE" which opens a specific terminal conductor switch. The command line used is "Open LINE.6 2 1" to break the conductor in phase 1 on the terminal 2 of line 6. As seen from Figure 3.1 all distribution transformers in the test-bed will therefore be influenced by the interrupted supply. The complex line-line and line-neutral voltages post-fault are shown in Table 3.4.

Table 3.4 Broken Conductor Line 6 Phase 1 for Case 1 in Example 1

	Bus 1	Bus 17	Bus 1LV	Bus 14_1	Bus 10LV	Bus 12_1	Bus 9LV	Bus 12_2	Bus 13LV
V1n[p.u.]	1.48 ∠ 1.8°	0.04 ∠ 91.9°	0.01 ∠ -14.2°	0.04 ∠ 91.9°	0.01 ∠ -14.5°	0.04 ∠ 91.9°	0.01 ∠ -14.5°	0.04 ∠ 91.9°	0.50 ∠ 88.5°
V2n[p.u.]	0.82∠- 91.3°	0.82∠- 91.4°	0.90 ∠-90.9°	0.82∠- 91.4°	0.86 ∠-91.1°	0.82∠- 91.4°	0.90 ∠-91.1°	0.82∠- 91.4°	1.00 ∠-90.5°
V3n[p.u.]	0.91 ∠ 90.9°	0.91 ∠ 90.8°	0.90 ∠ 89.8°	0.91 ∠ 90.8°	0.86 ∠ 89.5°	0.91 ∠ 90.8°	0.90 ∠ 89.5°	0.91 ∠ 90.8°	0.50 ∠ 90.5°
Vnn[p.u.]	0.01 ∠ 93.7°	0.05∠ 104.2°	0	-	0	0.05∠ 104.3°	0	0.05∠ 104.3°	0
V12[p.u.]	1.00 ∠ 30.0°	0.50 ∠ 88.8°	0.52 ∠ 88.5°	0.50 ∠ 88.8°	0.49 ∠ 88.2°	0.50 ∠ 88.8°	0.52 ∠ 88.2°	0.50 ∠ 88.8°	0.86 ∠ 89.2°
V23[p.u.]	1.00 ∠-90.1°	1.00 ∠-90.2°	1.04 ∠-90.6°	1.00 ∠-90.2°	0.99 ∠-90.8°	1.00 ∠-90.2°	1.03 ∠-90.8°	1.00 ∠-90.2°	0.87 ∠-90.2°
V31[p.u.]	1.00 ∠ 149.9°	0.50 ∠ 90.9°	0.52 ∠ 90.4°	0.50 ∠ 90.8°	0.50 ∠ 90.2°	0.50 ∠ 90.8°	0.52 ∠ 90.2°	0.50 ∠ 90.8°	0.01 ∠ 165.8°
Trans- former			Yyn0 / TT		Dd0 / IT		Yyn0 / IT		Dyn11 / TN

For further comparison and analysis it should be noted that each of the four LV busbars shown represent different distribution transformer vector group and system configuration. The vector group and system configuration is shown in the last row for each distribution transformer secondary voltage and each simulated case. In addition to the voltages in bus

1 at the supply end the results for bus 17, 14_1, 12_1 and 12_2 are for high voltage side of the respective four distribution transformers.

Case 2 – Broken conductor location towards the end of feeder

This case examine the LV voltages with a fault location towards the end of the feeder. Using same command as for the case 1 for phase 1 on line 20 the complex line-line and line-neutral voltages post-fault are as shown in Table 3.5.

Table 3.5 Broken Conductor Line 20 Phase 1 for Case 2 in Example 1

	Bus 1	Bus 17	Bus 1LV	Bus 14_1	Bus 10LV	Bus 12_1	Bus 9LV	Bus 12_2	Bus 13LV
V1n[p.u.]	1.31 ∠ 0.9°	0.12 ∠ 154.8°	0.05 ∠ 21.7°	0.12 ∠ 154.8°	0.05 ∠ 21.4°	0.01 ∠ 154.8°	0.05 ∠ 21.4°	0.01 ∠ 154.8°	0.52 ∠ 84.9°
V2n[p.u.]	0.86 ∠ -102.4°	0.86 ∠ -102.5°	0.91 ∠ -92.1°	0.86 ∠ -102.5°	0.87 ∠ -92.3°	0.86 ∠ -102.5°	0.90 ∠ -92.4°	0.86 ∠ -102.5°	1.00 ∠ -90.5°
V3n[p.u.]	0.91 ∠ 101.5°	0.91 ∠ 101.4°	0.89 ∠ 91.0°	0.91 ∠ 101.4°	0.85 ∠ 90.8°	0.91 ∠ 101.4°	0.89 ∠ 90.8°	0.91 ∠ 101.4°	0.48 ∠ 94.4°
Vnn[p.u.]	0.01 ∠ 93.8°	0.16 ∠ 168.3°	0	-	0	0.16 ∠ 168.3°	0	0.16 ∠ 168.3°	0
V12[p.u.]	1.00 ∠ 29.9°	0.52 ∠ 85.2°	0.54 ∠ 84.9°	0.52 ∠ 85.2°	0.51 ∠ 84.6°	0.52 ∠ 85.2°	0.54 ∠ 84.6°	0.52 ∠ 85.2°	0.88 ∠ 88.0°
V23[p.u.]	1.00 ∠ -90.1°	1.00 ∠ -90.2°	1.04 ∠ -90.5°	1.00 ∠ -90.2°	0.99 ∠ -90.8°	1.00 ∠ -90.2°	1.04 ∠ -90.8°	1.00 ∠ -90.2°	0.86 ∠ -88.9°
V31[p.u.]	1.00 ∠ 149.9°	0.49 ∠ 168.3°	0.51 ∠ 94.3°	0.49 ∠ 94.7°	0.48 ∠ 94.1°	0.49 ∠ 94.7°	0.50 ∠ 94.1°	0.49 ∠ 94.7°	0.05 ∠ 158.3°
Transformer			Yyn0 / TT		Dd0 / IT		Yyn0 / IT		Dyn11 / TN

The notable difference between the two cases is that the relative angle between each phase differs. For case 2 where the broken conductor is further out on the line the line-to-neutral voltage for the faulted phase changes from a negative angle of around -15° to a positive angle of about 20° on the LV side of the distribution transformers of all vector

groups. The line-to-line and line-to-neutral voltage magnitudes of both faulted and non-faulted phases have a minor increase. As for the line-to-line voltages on the LV system the change of angle is in the order of 3-5 degrees.

A summary of the results for the broken conductor gives the following voltages on the LV side of the transformers is shown in Table 3.6.

Table 3.6 Summary of Results for Broken Conductor Example 1

	Yyn0 / TT	Dd0	Yyn0 / IT	Dyn11 / TN
V_{LN}	Two reduced line-neutral voltages opposite in phase and one line-neutral close to zero	Two reduced line-neutral voltages opposite in phase and one line-neutral close to zero	Two reduced line-neutral voltages opposite in phase and one line-neutral close to zero	Two half magnitude line-neutral voltages in phase that are opposite in phase to last line-neutral voltage
V_{LL}	Two half magnitude line-line voltages in phase that are opposite in phase to last line-line voltage	Two half magnitude line-line voltages in phase that are opposite in phase to last line-line voltage	Two half magnitude line-line voltages in phase that are opposite in phase to last line-line voltage	Two reduced line-line voltages opposite in phase and one line-line close to zero

Table 3.7 shows the voltage vectors for all three phases for both phase and line voltages. The voltages shown are taken from Table 3.5 which gives the results having most phase angle difference of the two cases.

Looking at the wye-wye and the delta-delta type of transformers, it is the relative angle difference between the two line-to-line voltages towards the faulted phase that increase or decrease as of where the broken conductor is located.

Table 3.7 Voltage Vectors for Broken Conductor Example 1

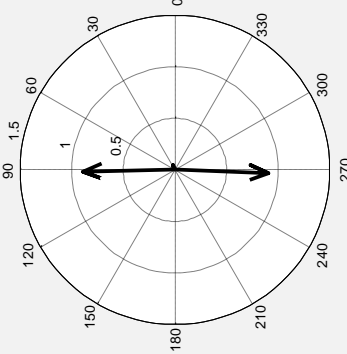
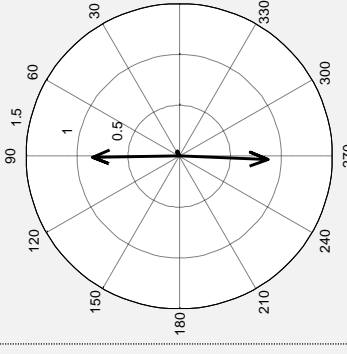
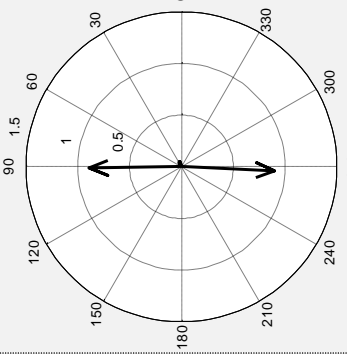
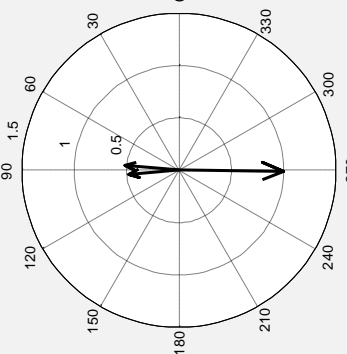
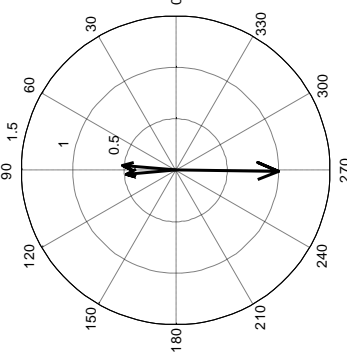
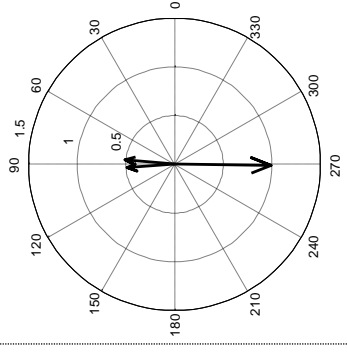
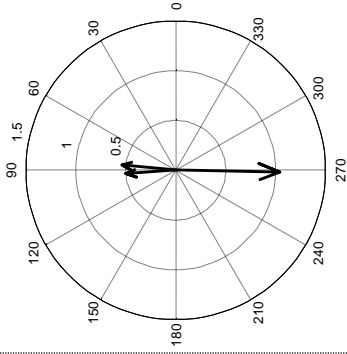
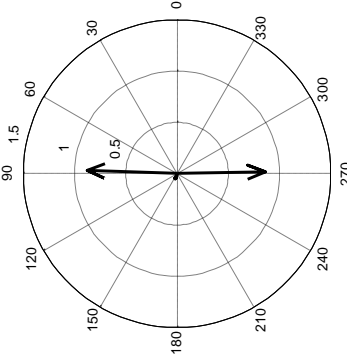
	Yyn0 / TT	Dd0	Yyn0 / IT	Dyn11 / TN
V_{LN}				
V_{LL}				

An extra test done on a broken conductor on phase 1 in line 26 resulted in a relative phase difference between these two mentioned line-to-line voltages by 20 degrees for the wye-wye and delta-delta connection groups. This special case seems to give the more deviation for the mentioned transformer vector groups in the test bed used than what is shown in Table 3.7.

An additional attempt to exchange position of transformer 13 and transformer 10 was done to examine the impact of a broken conductor in phase 1 on line 26. The results showed similar change in line-neutral voltages for transformer 13 as for the line-line voltages mentioned in the previous paragraph. As for the line-to-line LV voltages for transformer 13 in the new position, the results gave more deviations for the voltage magnitudes and the same 20 degrees change for the lowest voltage magnitude.

3.3 Example 2 – Back-fed ground fault in primary distribution system

A downed conductor or a back-fed conductor is a broken conductor that has a connection to ground on the downstream side of conductor, i.e. towards the customer. Table 3.5 shows the results of this simulation done in OpenDSS. In this test, a back-fed ground fault is located using line 6 and phase 1 for the ground connection.

The term ‘fault’ in this context refers to a *downed conductor* where the downstream side of the broken conductor makes the abnormal situation. The same two cases used in example 1 for the location of the fault is also performed in this example. A case where the ‘fault’ is located on the radial in a close proximity to the distribution transformer is also added to this example. This due to the fact that this case gives an outcome that is an extreme case for this specific example.

Case 1 – Back-fed ground fault location at beginning of feeder

In order to simulate a back-fed ground fault in OpenDSS the terminal connections for the respective line is altered. Using the command "LINE.6.Bus1=2.0.2.3" disconnects phase 1 in line 6 from the bus terminal at the bus1 end of the line and connects it to ground in order to simulate the direct ground fault connection on the downstream side of the line. The results for the complex line-line and line-neutral voltages post-fault are shown in Figure 3.8.

Table 3.8 Back-Fed Ground Fault Phase 1 Line 6 – Case 1

	Bus 1	Bus 17	Bus 1LV	Bus 14_1	Bus 10LV	Bus 12_1	Bus 9LV	Bus 12_2	Bus 13LV
V1n[p.u.]	1.47 ∠ 0.8°	0.00 ∠ 128.4°	0.02 ∠ -36.1°	0.00 ∠ 128.6°	0.02∠- 36.3°	0.00 ∠ 127.0°	0.02 ∠ -36.3°	0.00 ∠ 127.0°	0.49 ∠ 87.6°
V2n[p.u.]	0.84 ∠ -92.1°	0.85 ∠ -92.2°	0.90 ∠ -91.2°	0.85 ∠ -92.2°	0.85 ∠ -91.4°	0.85 ∠ -92.2°	0.89∠- 91.4°	0.85 ∠ -92.2°	1.00 ∠ -90.5°
V3n[p.u.]	0.89 ∠ 91.7°	0.89 ∠ 91.6°	0.91 ∠ 90.1°	0.89 ∠ 91.6°	0.87 ∠ 89.8°	0.89 ∠ 91.6°	0.91∠ 89.8°	0.89 ∠ 91.6°	0.51 ∠ 91.4°
Vnn[p.u.]	0.01 ∠ 90.8°	0.02 ∠ 144.3°	0	-	0	0.02 ∠ 144.3°	0	0.02 ∠ 144.3°	0
V12[p.u.]	1.00 ∠ 30.0°	0.49 ∠ 87.8°	0.51 ∠ 87.5°	0.49 ∠ 87.8°	0.48 ∠ 87.3°	0.49 ∠ 87.8°	0.51∠ 87.3°	0.49 ∠ 87.8°	0.86 ∠ 88.9°
V23[p.u.]	1.00 ∠ -90.1°	1.00 ∠ -90.2°	1.04 ∠ -90.6°	1.00 ∠ -90.2°	0.99 ∠ -90.8°	1.00 ∠ -90.2°	1.04∠- 90.8°	1.00 ∠ -90.2°	0.87 ∠ -89.9°
V31[p.u.]	1.00 ∠ 149.9°	0.51 ∠ 91.6°	0.53 ∠ 91.3°	0.51 ∠ 91.6°	0.51 ∠ 91.1°	0.51 ∠ 91.6°	0.53∠ 91.1°	0.51 ∠ 91.6°	0.02 ∠ 144.0°
Trans- former			Yyn0 / TT		Dd0 / IT		Yyn0 / IT		Dyn11 / TN

Case 2 – Back-fed ground fault location towards the end of feeder

A second case of back-fed ground fault is simulating a ground fault preceding a broken conductor on line 20. The OpenDSS command "LINE.20.Bus1=11.0.2.3" open

the first phase on line 20 from connection on bus 11 and connect the downstream side of the line to ground potential. The results are shown in Table 3.9. As seen from the test-bed circuit in Figure 3.1, the location of the fault is right where the feeder is divided up into two radial branches having one of each discussed type of distribution transformer vector group.

Table 3.9 Back-Fed Ground Fault Phase 1 on Line 20 – Case 2

	Bus 1	Bus 17	Bus 1LV	Bus 14_1	Bus 10LV	Bus 12_1	Bus 9LV	Bus 12_2	Bus 13LV
V1n[p.u.]	1.39 ∠ 0.3°	0.00 ∠ 175.2°	0.07 ∠ -5.2°	0.00 ∠ 175.2°	0.07 ∠ -5.4°	0.00 ∠ 175.3°	0.07 ∠ -5.5°	0.00 ∠ 175.3°	0.50 ∠ 82.5°
V2n[p.u.]	0.87 ∠ -97.2°	0.87 ∠ -97.3°	0.90 ∠ -92.9°	0.87 ∠ -97.3°	0.86 ∠ -93.1°	0.87 ∠ -97.3°	0.90 ∠ -93.1°	0.87 ∠ -97.3°	1.00 ∠ -90.5°
V3n[p.u.]	0.88 ∠ 96.8°	0.88 ∠ 96.7°	0.91 ∠ 91.8°	0.88 ∠ 96.7°	0.86 ∠ 91.5°	0.88 ∠ 96.7°	0.90 ∠ 91.5°	0.88 ∠ 96.7°	0.51 ∠ 96.4°
Vnn[p.u.]	0.01 ∠ 89.4°	0.07 ∠ 175.2°	0	-	0	0.07 ∠ 175.2°	0	0.07 ∠ 175.2°	0
V12[p.u.]	1.00 ∠ 29.9°	0.50 ∠ 82.7°	0.52 ∠ 82.4°	0.50 ∠ 82.7°	0.49 ∠ 82.2°	0.50 ∠ 82.7°	0.52 ∠ 82.2°	0.50 ∠ 82.7°	0.86 ∠ 87.2°
V23[p.u.]	1.00 ∠ -90.1°	1.00 ∠ -90.2°	1.04 ∠ -90.5°	1.00 ∠ -90.2°	0.99 ∠ -90.8°	1.00 ∠ -90.2°	1.04 ∠ -90.8°	1.00 ∠ -90.2°	0.87 ∠ -88.2°
V31[p.u.]	1.00 ∠ 149.9°	0.51 ∠ 96.7°	0.53 ∠ 96.4°	0.51 ∠ 96.7°	0.50 ∠ 96.1°	0.51 ∠ 96.7°	0.53 ∠ 96.1°	0.51 ∠ 96.7°	0.07 ∠ 174.9°
Transformer			Yyn0 / TT		Dd0 / IT		Yyn0 / IT		Dyn11 / TN

Case 3 – Back-fed ground fault location on radial line into transformer bus

The last case for example 3 regarding back-fed ground fault accounts for a fault location on the radial line connections going towards the respective distribution transformer vector groups. Using the same command in OpenDSS as for the previous 2 cases a back-fed fault is applied to line 15, 27, 21 and 22 one at a time for transformers 1, 10, 9

and 13 respectively. Table 3.10 thus reflects 4 different situations with 4 different fault locations

Table 3.10 Back-Fed Ground Fault Close to Distribution Transformers – Case 3

	Bus 1	Bus 17	Bus 1LV	Bus 14_1	Bus 10LV	Bus 12_1	Bus 9LV	Bus 12_2	Bus 13LV
V1n[p.u.]	-	0.00 ∠ 170.5°	0.34 ∠ 2.1°	0.00 ∠ 179.1°	0.28 ∠ 0.6°	0.00 ∠ 171.1°	0.29 ∠ 8.1°	0.00 ∠ 172.9°	0.59 ∠ 63.4°
V2n[p.u.]	-	1.02 ∠ -119.6°	0.93 ∠ -101.4°	0.97 ∠ -115.9°	0.87 ∠ -100.0°	1.01 ∠ -114.1°	0.93 ∠ -99.6°	1.02 ∠ -116.3°	1.00 ∠ -90.5°
V3n[p.u.]	-	0.98 ∠ 120.5°	0.91 ∠ 100.4°	0.96 ∠ 116.0°	0.87 ∠ 98.5°	0.90 ∠ 117.0°	0.89 ∠ 98.4°	0.93 ∠ 118.9°	0.54 ∠ 118.6°
Vnn[p.u.]	-	0.33 ∠ 177.5°	0	-	0	0.28 ∠ 171.3°	0	-	0
V12[p.u.]	-	0.59 ∠ 60.4°	0.61 ∠ 60.1°	0.56 ∠ 64.1°	0.56 ∠ 63.5°	0.59 ∠ 65.9°	0.61 ∠ 65.4°	0.59 ∠ 63.7°	0.90 ∠ 79.9°
V23[p.u.]	-	1.00 ∠ -90.2°	1.04 ∠ -90.5°	1.00 ∠ -90.2°	0.99 ∠ -90.8°	1.00 ∠ -90.2°	1.04 ∠ -90.8°	1.00 ∠ -90.2°	0.86 ∠ -80.4°
V31[p.u.]	-	0.57 ∠ 120.5°	0.59 ∠ 120.2°	0.55 ∠ 116.0°	0.55 ∠ 115.4°	0.52 ∠ 117.0°	0.54 ∠ 116.4°	0.54 ∠ 118.9°	0.30 ∠ 173.5°
Transformer	-		Yyn0 / TT		Dd0 / IT		Yyn0 / IT		Dyn11 / TN

Since Table 3.10 includes four different situations, only the results for the HV and LV side of transformer 1, 10, 9 and 13 are shown in Table 3.12 and the results for bus 1 are omitted. As seen from Table 3.11 the relative angle difference between two of the line-to-line voltages are up to 60 degrees for the wye-wye connection with grounded secondary neutral.

Summarized in Table 3.11 are the results for the back-fed ground fault / downed conductor example including all three cases. Table 3.12 shows how the voltage vectors for all three phases for both phase and line voltages.

The voltages shown are taken from Table 3.11 which gives the results having greatest phase angle difference of the three cases for the back-fed ground fault example.

Table 3.11 Summarized Results Back-Fed Ground Fault – Example 2

	Yyn0 / TT	Dd0	Yyn0 / IT	Dyn11 / TN
V_{LN}	Two reduced line-neutral voltages opposite in phase and one line-neutral voltage in the range from zero to 1/3 p.u. value depending on location of fault	Two reduced line-neutral voltages opposite in phase and one line-neutral voltage in the range from zero to less than 1/3 p.u. value depending on location of fault	Two reduced line-neutral voltages opposite in phase and one line-neutral voltage in the range from zero to less than 1/3 p.u. value depending on location of fault	One line-to line voltage opposite in phase with two close to half magnitude line-line voltages in phase. The two half magnitude voltages having a relative angle difference of up to 55°
V_{LL}	One line-to-line voltage opposite in phase with two close to half magnitude line-to-line voltages in phase. The two half magnitude voltages having a relative angle difference of up to 60°	One line-to line voltage opposite in phase with two close to half magnitude line-to-line voltages in phase. The two half magnitude voltages having a relative angle difference of up to 52°	One line-to line voltage opposite in phase with two close to half magnitude line-to-line voltages in phase. The two half magnitude voltages having a relative angle difference of up to 51°	Two reduced line-neutral voltages opposite in phase and one line-neutral voltage in the range from zero to less than 1/3 p.u. value depending on location of fault

The results for the back-fed ground fault vary in magnitude depending with the location of the fault's relative proximity to the distribution transformers. For the wye-wye and delta-delta connected transformers the secondary line-to-line voltage connected to the faulted phase increase from 0.49 to 0.61 p.u. the closer the fault is to the transformer, whereas the secondary line-to-neutral voltage for the faulted phase varies from 0 to 0.34 p.u. for the same connection groups.

Table 3.12 Voltage Vectors for Back-Fed Ground Fault - Example 2

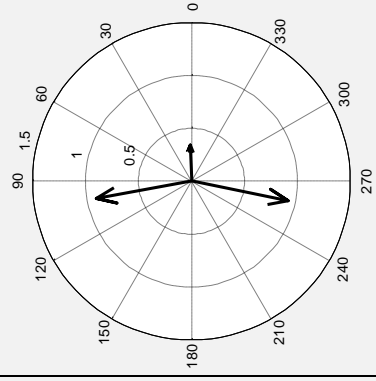
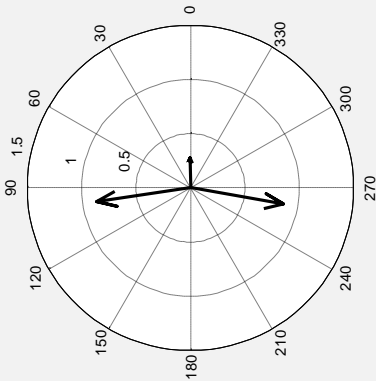
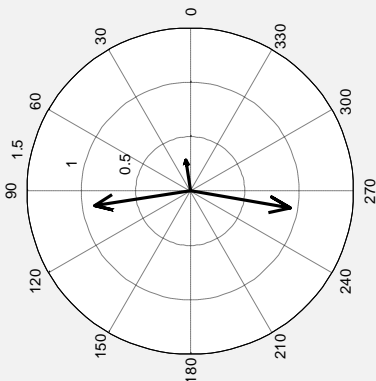
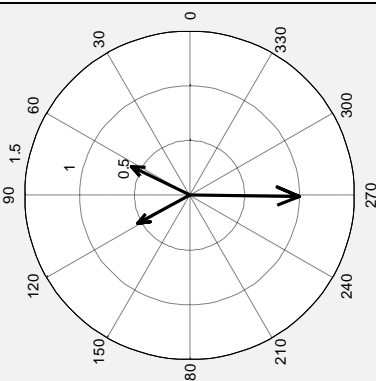
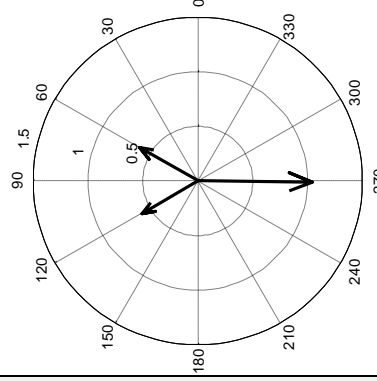
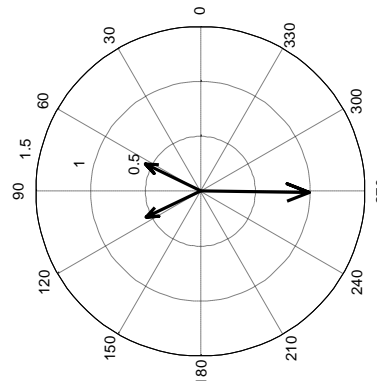
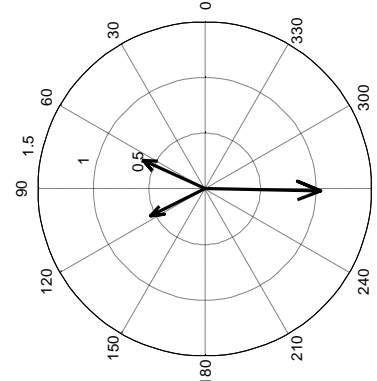
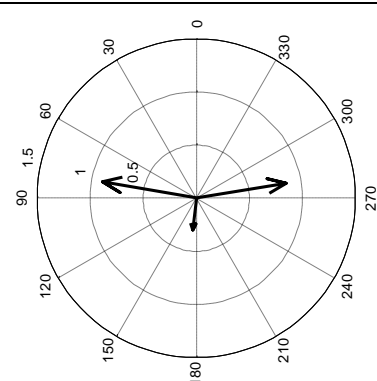
	Yyn0 / TT	Dd0	Yyn0 / IT	Dyn11 / TN
V_{LN}				
V_{LL}				

Looking at the delta-wye connecting transformers, the results show the same pattern where the line-to-line voltages are similar to the line-to-neutral voltages for wye-wye and the line-to-neutral voltages are similar to the line-to-line voltages.

A simulation using a fault resistance 40Ω (often used in single line-to-ground fault studies) has also been performed for the different cases in example 2 in order to see if that would have any impact on the results shown in the results tabulated in Tables 3.11 and 3.12. The simulations incorporating the 40Ω fault resistance showed no particular pattern other than that the voltage phase angles changed in the order of 1-2 degrees and the voltage magnitudes changed in the order of 0.01-0.02 p.u. Some results showed no change at all.

3.4 Example 3 – Single line-to-ground fault primary distribution system

A single phase to ground fault in the primary distribution system is included as an example to examine the impact on the LV side of distribution transformers and to see whether the results are similar to the ones of a broken conductor or a back-fed ground fault. One case only is simulated for single line to ground fault and included in the results. The OpenDSS command used in this example is "new Fault.F1 bus 1=6.1 phases=1". This command applies a single line to ground fault directly to ground on bus 6 in the MV primary distribution system with no fault impedance. The results are shown in Table 3.14.

A simulation using a fault resistance of 40Ω has also been performed to check the further impact of a fault resistance compared to a direct to ground fault. Even though the MV voltage magnitudes increase by a factor of $\sqrt{3}$ in the two unfaulted phases, the LV volt-

ages for all the different transformer connection types stay more or less the same as the ones shown in Table 3.13 for direct line to ground faults. This counts for both angles and magnitudes of voltages. As seen from Table 3.13, neither the line-to-line nor the line-to-neutral voltages on the LV voltages is influenced by a single line-to-ground fault.

Table 3.13 Single Line-Ground Fault in Phase 1 for MV System Bus 6 – Example 3

	Bus 1	Bus 17	Bus 1LV	Bus 14_1	Bus 10LV	Bus 12_1	Bus 9LV	Bus 12_2	Bus 13LV
V1n[p.u.]	0.00 ∠ 110.6°	0.00 ∠ 112.2°	1.02 ∠ -1.8°	0.00 ∠ 84.5°	0.98 ∠ -1.3°	0.00 ∠ 114.7°	0.99 ∠ -0.8°	0.00 ∠ 141.0°	0.98 ∠ 29.5°
V2n[p.u.]	1.74 ∠ -150.2°	1.74 ∠ -150.2°	1.02 ∠ -121.9°	1.74 ∠ -150.2°	0.98 ∠ -121.3°	1.74 ∠ -150.2°	0.99 ∠ -120.9°	1.74 ∠ -150.3°	0.98 ∠ -90.5°
V3n[p.u.]	1.74 ∠ 149.9°	1.74 ∠ 149.9°	1.02 ∠ 118.2°	1.74 ∠ 149.9°	0.98 ∠ 118.8°	1.74 ∠ 149.9°	0.99 ∠ 119.2°	1.74 ∠ 149.8°	0.98 ∠ 149.5°
Vnn[p.u.]	0.03 ∠ -91.9°	1.00 ∠ -179.8°	0.00 ∠ -89.8°	-	0.00 ∠ -23.9°	1.00 ∠ -179.8°	0.00 ∠ -90.2°	-	0
V12[p.u.]	1.00 ∠ 29.8°	1.00 ∠ 29.8°	1.02 ∠ 28.1°	1.00 ∠ 29.8°	0.98 ∠ 28.7°	1.00 ∠ 29.8°	0.99 ∠ 29.1°	1.00 ∠ 29.7°	0.98 ∠ 59.5°
V23[p.u.]	1.00 ∠ -90.1°	1.00 ∠ -90.1°	1.02 ∠ -91.8°	1.00 ∠ -90.2°	0.98 ∠ -91.3°	1.00 ∠ -90.2°	0.99 ∠ -90.8°	1.00 ∠ -90.2°	0.98 ∠ -60.5°
V31[p.u.]	1.00 ∠ 149.9°	1.00 ∠ 149.9°	1.02 ∠ 148.2°	1.00 ∠ 149.9°	0.98 ∠ 148.8°	1.00 ∠ 149.9°	0.99 ∠ 149.2°	1.00 ∠ 149.8°	0.98 ∠ 179.5°
Transformer			Yyn0 / TT		Dd0 / IT		Yyn0 / IT		Dyn11 / TN

3.5 Example 4 – Single line-to-ground fault secondary distribution system

In this example a single phase to ground fault has been applied to the secondary distribution system at the LV side of the previous simulated distribution transformers. This to verify the resulting line-to-neutral and line-to-line voltages for different distribution transformer connection types as well as the various transformer vector groups. Variations are done for wye-wye and delta-wye. The OpenDSS command used in this example

is "new Fault.F1 bus 1=13LV.1 phases=1". This command applies a single line to ground fault directly to ground on the LV bus of transformer 13. The same command is applied on bus 9LV, 10LV and 1LV for transformers T.9, T.10 and T.1 respectively. The results for a fault on the LV side of transformer 13 is shown in Table 3.14

Table 3.14 Single Phase-Ground Fault in Phase 1 for LV Side of Transformer 13

	Bus 1	Bus 17	Bus 1LV	Bus 14_1	Bus 10LV	Bus 12_1	Bus 9LV	Bus 12_2	Bus 13LV
V1n[p.u.]	1.00 ∠-0.1°	1.00∠-0.1°	1.02∠-1.8°	1.00∠-0.2°	0.96∠-2.7°	1.00∠-0.2°	0.98∠-2.2°	1.00∠-0.2°	0.00∠-27.0°
V2n[p.u.]	1.00 ∠-120.2°	1.00∠-120.2°	1.02∠-121.8°	1.00∠-120.2°	0.95∠-121.1°	1.00∠-120.2°	0.96∠-12.7°	1.00∠-120.2°	0.99∠-89.4°
V3n[p.u.]	1.00 ∠119.9°	1.00∠119.9°	1.02∠118.2°	1.00∠119.8°	0.98∠118.7°	1.00∠119.8°	0.99∠119.2°	1.00∠119.8°	0.99∠148.3°
Vnn[p.u.]	0	0	0	-	0	-	0	-	0
V12[p.u.]	1.00 ∠29.9°	1.00∠29.9°	1.02∠28.2°	1.00∠29.8°	0.95∠27.8°	1.00∠29.8°	0.96∠-28.3°	1.00∠29.4°	0.57∠90.6°
V23[p.u.]	1.00 ∠-90.1°	1.00∠-90.1°	1.02∠-91.8°	1.00∠-90.2°	0.96∠-90.7°	1.00∠-90.1°	0.98∠-90.3°	1.00∠-89.0°	1.00∠-60.3°
V31[p.u.]	1.00∠149.8°	1.00∠149.8°	1.02∠148.2°	1.00∠149.8°	0.98∠147.7°	1.00∠149.9°	0.99∠148.2°	1.00∠148.4°	0.57∠148.3°
Transformer			Yyn0 / TT		Dd0 / IT		Yyn0 / IT		Dyn11 / TN

From Table 3.14, it is clear that a ground fault on the LV side of the transformer does not influence the voltages on the primary distribution system. Hence for the simulations for the remainder of the different types of distribution transformers, only the voltage on the HV and LV side of the respective transformer is included in one single table as shown in Table 3.14. The results for transformer 13 are also included in Table 3.15 for comparison.

The results in Table 3.15 show that for the wye-wye and delta-delta connected transformers the line-neutral voltages for the faulted LV phase goes to zero and the other increase by a factor of $\sqrt{3}$. As for the line-line voltages, these voltages are nearly unchanged. As for the delta-wye connection, only the faulted line-ground phase goes to zero, while the other two line-to-ground voltage magnitudes stay the same. The line-line voltages for the LV side of the delta-wye connection show just above half magnitude voltages being almost 60 degrees apart. The vector sum of these are opposite in phase and equal to the third line-line voltage. This is the same pattern as found for the line-line LV side voltages for the back-fed ground fault in example 2.

Table 3.15 Single Line-Ground Fault in Phase 1 for LV Side of Transformers - Example 4

	Bus 1	Bus 17	Bus 1LV	Bus 14_1	Bus 10LV	Bus 12_1	Bus 9LV	Bus 12_2	Bus 13LV
V1n[p.u.]	-	1.00 $\angle -0.1^\circ$	0.00 $\angle -0.5^\circ$	1.00 $\angle -0.2^\circ$	0.00 $\angle -90.8^\circ$	1.00 $\angle -0.1^\circ$	0.00 $\angle -90.8^\circ$	1.00 $\angle -0.2^\circ$	0.00 $\angle -27.0^\circ$
V2n[p.u.]	-	1.00 $\angle -120.1^\circ$	1.81 $\angle -150.5^\circ$	1.00 $\angle -120.2^\circ$	1.72 $\angle -150.8^\circ$	1.00 $\angle -120.1^\circ$	1.80 $\angle -150.8^\circ$	1.00 $\angle -120.2^\circ$	0.99 $\angle -89.4^\circ$
V3n[p.u.]	-	1.00 $\angle 119.9^\circ$	1.81 $\angle 148.5^\circ$	1.00 $\angle 119.8^\circ$	1.72 $\angle 149.2^\circ$	1.00 $\angle 119.9^\circ$	1.80 $\angle 149.2^\circ$	1.00 $\angle 119.8^\circ$	0.99 $\angle 148.3^\circ$
Vnn[p.u.]	-	0	0	-	0.85 $\angle 179.2^\circ$	-	1.04 $\angle 179.2^\circ$	-	0
V12[p.u.]	-	1.00 $\angle 29.9^\circ$	1.04 $\angle 29.5^\circ$	1.00 $\angle 29.8^\circ$	0.99 $\angle 29.2^\circ$	1.00 $\angle 29.8^\circ$	1.04 $\angle -29.2^\circ$	1.00 $\angle 29.4^\circ$	0.57 $\angle 90.6^\circ$
V23[p.u.]	-	1.00 $\angle -90.1^\circ$	1.04 $\angle -90.5^\circ$	1.00 $\angle -90.2^\circ$	0.99 $\angle -90.8^\circ$	1.00 $\angle -90.1^\circ$	1.04 $\angle -90.8^\circ$	1.00 $\angle -89.0^\circ$	1.00 $\angle -60.3^\circ$
V31[p.u.]	-	1.00 $\angle 149.9^\circ$	1.04 $\angle 149.5^\circ$	1.00 $\angle 149.8^\circ$	0.99 $\angle 149.2^\circ$	1.00 $\angle 149.9^\circ$	1.04 $\angle 149.2^\circ$	1.00 $\angle 148.4^\circ$	0.57 $\angle 148.3^\circ$
Transformer			Yyn0 / TT		Dd0		Yyn0 / IT		Dyn11 / TN

3.6 Example 5 – Two line-to-ground fault primary distribution system

The last example include a short circuit fault with two line-to-ground fault applied on the primary distribution system side. This to verify whether this fault has the same type of results as the broken conductor and / or the back-fed ground fault. The OpenDSS command used in this example is "new Fault.F1 bus 1=7.1.2 phases=2". This command applies a double-line to ground fault directly to ground on the HV bus 7. The results from the simulation are shown in Table 3.16.

A double line to ground fault on the primary distribution system will be detected by the protection relay on the substations feeders within a predetermined set time. The clearing time will depend on the setting of the relay and the selectivity chosen for that particular part of the distribution system including all feeders at the particular substation.

Table 3.16 Double Line-Ground Fault at Bus 6 in MV System – Example 5

	Bus 1	Bus 17	Bus 1LV	Bus 14_1	Bus 10LV	Bus 12_1	Bus 9LV	Bus 12_2	Bus 13LV
V1n[p.u.]	0.24∠ 13.8°	0.00∠ 70.2°	0.52∠ - 60.6°	0.00∠ 71.4°	0.50∠ - 60.8°	0.00∠ 54.9°	0.52∠ - 60.8°	0.00∠ 54.9°	0.00∠ - 38.4°
V2n[p.u.]	0.24∠- 166.3°	0.00∠80.8 °	0.52∠- 60.6°	0.00∠81.6 °	0.50∠- 60.8°	0.00∠ 69.6°	0.52∠- 60.8°	0.00∠ 69.6°	0.86∠- 60.9°
V3n[p.u.]	1.50∠ 119.9°	1.5∠ 119.8°	1.04∠ 119.4°	1.5∠ 119.8°	0.99∠ 119.2°	1.5∠ 119.8°	1.04∠ 119.1°	1.5∠ 119.8°	0.86∠ 119.1°
Vnn[p.u.]	0.01∠ 151.9°	0.5∠ 119.8°	0	-	0	0.5∠ 119.8°	0	-	0
V12[p.u.]	0.28∠ 13.7°	0.00∠- 52.3°	0.00∠ - 52.6°	0.00∠- 52.3°	0.00∠ 52.8°	0.00∠- 52.3°	0.00∠ 52.9°	0.00∠- 52.3°	0.50∠ 119.1°
V23[p.u.]	0.84∠- 69.3°	0.87∠- 60.2°	0.90∠- 60.6°	0.87∠- 60.2°	0.86∠- 60.8°	0.87∠- 60.2°	0.90∠- 60.8°	0.87∠- 60.2°	1.00∠- 60.9°
V31[p.u.]	0.91∠ 128.2°	0.87∠119. 8°	0.90∠ 119.4°	0.87∠ 119.8°	0.86∠ 119.2°	0.87∠ 119.8°	0.90∠ 119.2°	0.87∠ 119.8°	0.50∠ 119.1°
Trans- former	-	-	Yyn0 / TT	-	Dd0 / IT	-	Yyn0 / IT	-	Dyn11 / TN

The results in Table 3.16 show similar magnitudes and angles of those of the line-to-line voltages for the case of broken conductor in example 1. For a short circuit fault the wye-wye and delta-delta line-to-line voltages are similar to the ones for the delta-wye for a broken conductor. The line-to-line voltages in the delta-wye transformer for the short circuit appear to be similar to the wye-wye voltages for the broken conductor example. The only noticeable difference is that all three voltage angles are shifted with a certain phase angle. However, the relative angle differences are about the same.

An additional simulation with a fault resistance of 40Ω gave a result on the LV side of the distribution transformer for the delta-wye connection that looked even more like the line-to-line voltages for the wye-wye connection in the example of the broken conductor. Because of the high resistance, the simulation gave an outcome of line-to-line voltages for the wye-wye and delta-delta that were close to normal magnitudes.

3.7 Algorithms and system overview for detection

Based on the simulations and the results in the previous section, the line-to-line and the line-to-neutral voltages on the secondary side of the distribution transformer can be utilized making a set of algorithms of a back-fed ground fault/downed conductor detection. The main objective is to design a set of ‘rules’ useful to identify a specific type of abnormal operational condition. That operational condition can occur during the aftermath of a broken conductor that can cross over to become a back-fed ground fault. The ground connection may have a nonzero fault resistance or may be a direct back-fed ground fault. In the design of these ‘rules’, it is important not to flag a normal operating condition as abnormal. This type of *false alarm* in a given operating region could occur

due to other types of anomalous operating conditions in the normal operation of the distribution network. The cited issue of false alarms is the reason for inclusion of the single and double line-to-ground faults as separate simulations.

As indicated above, the objective is to design a set of rules to identify problematic conditions with a minimum number of false alarms and no false dismissals. The set of rules to detect both broken conductor and back-fed ground fault are as follows:

Rule 1. Two line-line voltages magnitude less than 65 % of rated voltage
(wye-wye/delta-delta)

Rule 2. One line-line voltage magnitude less than 40 % of rated voltage
(wye-delta/delta-wye)

Rule 3. One or two line-line magnitude above 80% of rated voltage
(all connection groups)

Rule 4. Angles between two line-line voltages differs by $145 - 215^\circ (\pm 35^\circ)$

Rule 5. Angles between any line-line voltage not equal to 120°

Rule 6. Vector sum of line-neutral voltages (zero-sequence voltage) less than
0.01 of rated voltage

Rule 7. Time delay of 3 seconds (after detection start)

As seen from the set of rules there is a natural grouping related to the main transformer as Rule 1 and 2. A second grouping, Rules 3-7 are common for all connection groups. In addition to the voltage magnitudes, the voltage phase angles are found to be the signature of a broken conductor and a back-fed ground fault as shown in Rules 4 and 5. The bus voltage phase angles will always have an angle different for 120° during such

faults when a conductor breaks. As for Rule 4, the area of angle variation depends of the type of fault. If a broken conductor occurs, the phase angle difference between voltages would typically be within $\pm 10^\circ$ as shown in Table 3.6, whereas the ground connection on the downstream side makes the angle up to $\pm 30^\circ$.

The Rule 6 is included due to the fact that the single line-to-ground on the fault can have a similar signature of a wye-delta/delta-wye connected transformer for its voltages on the LV side of the distribution transformer. Normally a single line-to-ground would be detected by the LV side fuse protection for the respective LV circuits to the customers or the HV side fuse. Although the time it takes for the fuses to disconnect the supply depends on the type of fault and on the fault impedance at the fault location. The algorithms are illustrated in the flow chart in Figure 3.3. A possible substitution for Rule 6 could be to have a Rule 1b and 2b where a rule of checking magnitude of line-to-neutral voltage is performed in addition to the check of line-to-line voltages.

When doing a simulation check for a short circuit on the primary distribution system the results revealed that a double line-to-ground fault could appear with the same relative angle differences and magnitudes as for a broken conductor. Rule 7 is therefore included as a time delay that flag a detection if the fault situation is persistent over a period of 2 seconds. A normal protection system for the outgoing feeders from a substation containing overcurrent relays would clear a short circuit fault within 0.2 to 1.5 seconds depending on the selectivity for that part of the system. In addition an extra time of 0.5 second is added in order to be sure that the fault is cleared.

Figure 3.4 shows a suggested implementation of detecting a broken conductor and / or a back-fed ground fault in the distribution system using smart grid components.

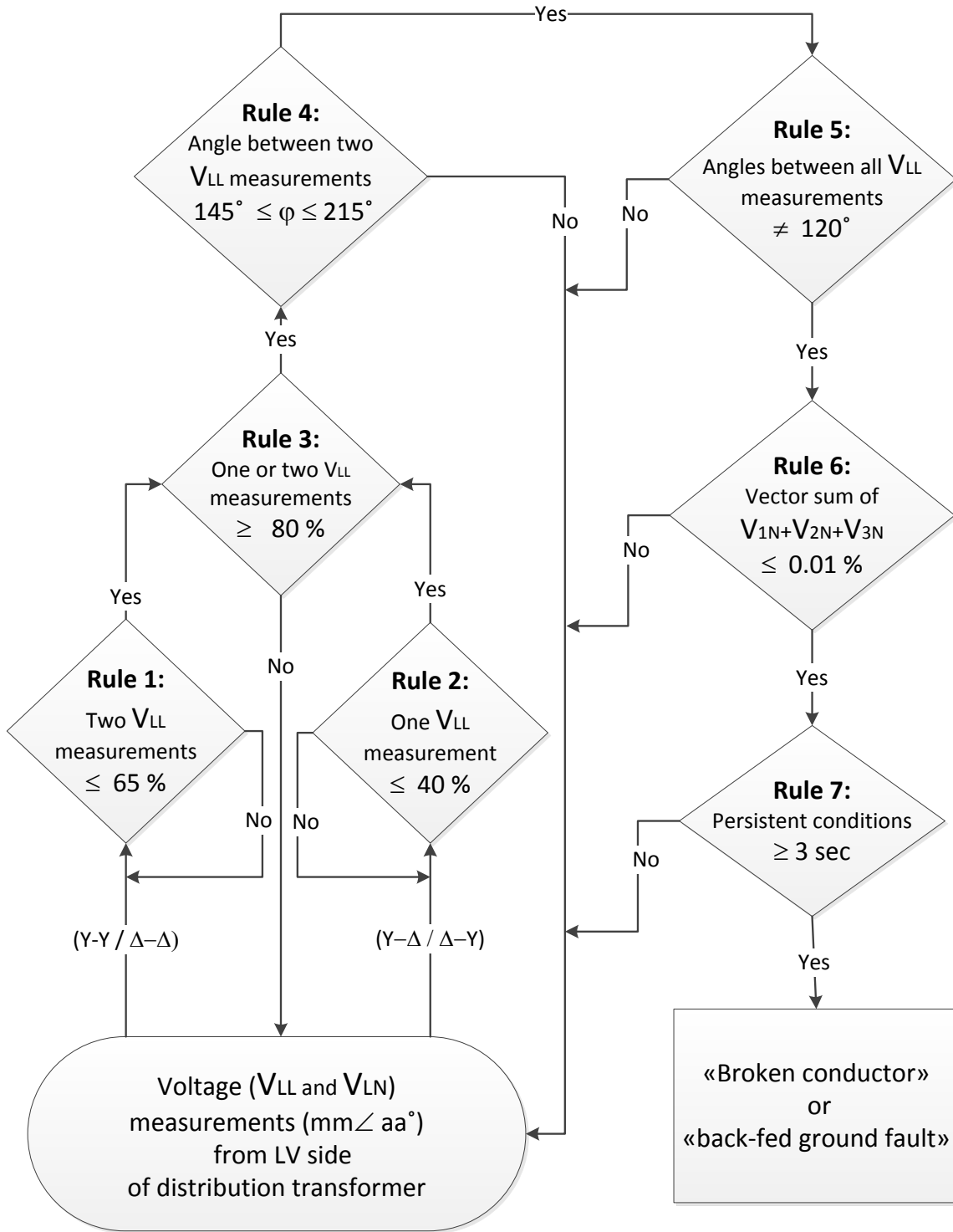

Figure 3.3 Flow Chart of Detection Algorithm

The set of rules are applied to data obtained from the voltage input from either a smart meter or a power analyzer / meter. This instrumentation can measure and (digitally) provide line-to-line and line-to-neutral voltages with magnitude and phase angle. Processing of the rules can be implemented in the smart meter or the power analyzer / meter if the device supports programming of algorithms.

Another solution where the local device does not support programming is to implement the set of rules in an event management program centralized located at the utility data center. That is, data gathering or data concentration is used for smart metering data collection. A third solution is to implement the algorithms in a local RTU based on the voltage inputs and transmit that signal for detection ON / OFF.

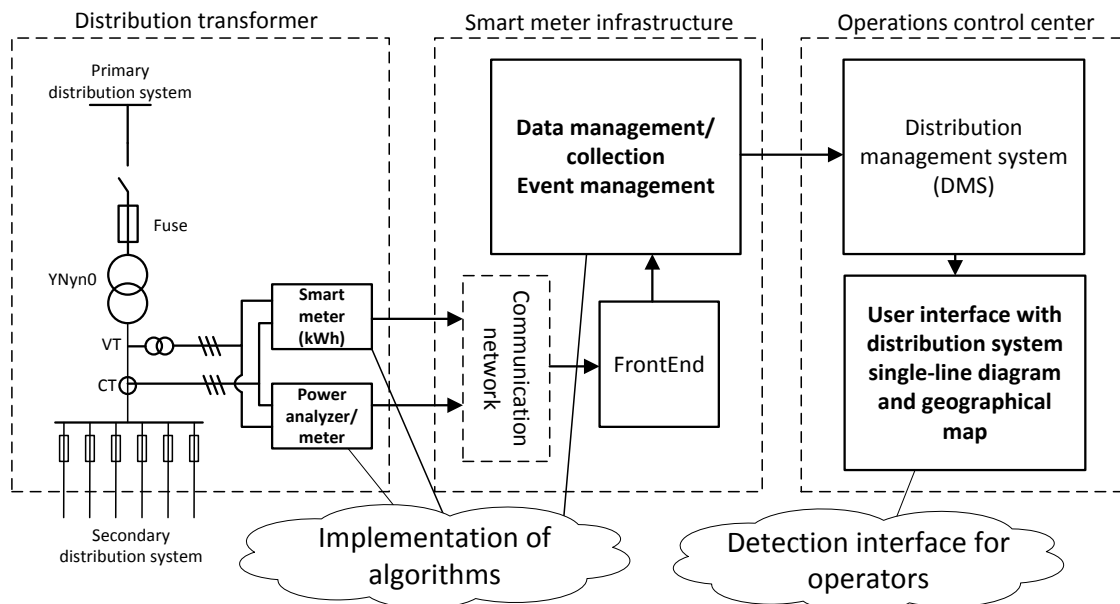

Figure 3.4 System Overview for Detection

The main object for a detection scheme is to present the detection of the abnormal situation in the distribution system for the operator at the operations control center. To

implement this, an integration between the smart meter infrastructure and distribution management system (DMS) is essential. An DMS system contains a full overview of the respective primary distribution system with single-line diagram and integrated geographical map. A detected back-fed ground fault or a broken conductor can by this be presented graphically as a symbol for each distribution transformer that sees the signature of the abnormal situation based of the set of rules implemented. In coarse features all distribution transformers located downstream of the fault location will detect and present the abnormal situation for the operator to take necessary action.

The foregoing is a suggested infrastructure to use ‘big data’ and ‘smart meters’ in ways suggested by the philosophy of the Smart Grid as discussed in [70-76]. In [70] it is even pointed out that many utilities have not fully understood the value of the data available in the smart metering infrastructure that is deployed around in the distribution systems. The Norwegian Smartgrid Centre [76] is performing research with pilot projects where the smart grid technology gets connected with the modern information technology systems. The method suggested in this thesis is just one out of many smart ways to utilized the numerous distribution grid electrical data that becomes readily available through the development of smart grid technology.

3.8 Evaluating and comparing results

Results from the simulations comply with voltage measurements presented in [35]. In this paper the authors present a figure that shows how the measured LV side line-to-neutral voltage change from around zero to about one third of the magnitude in a transition from a broken conductor to a back-fed ground fault in a real case.

A test report [77] from the company Nortroll that manufacture broken conductor indicators has been made available in the work with this thesis. A comparison with the results in the test report also comply with what the simulations presented in this thesis has shown. Correspondence with technical personnel from Nortroll [78] has provided input for the solution chosen for broken conductor identification. The results for examples 1 and 2 show a major difference between a broken conductor with and without a ground connection. When the broken conductor change into a back-fed ground fault the relative phase angle for the two half magnitude line-to-line secondary voltages for a wye-wye connected transformer increase from about 20 to 60 degrees. Also the one line-to-line secondary voltage in a delta-wye connected transformer changes from about 0.05 p.u. to 0.33 p.u. . The test report [77] also shows this pattern, but the cited phenomenon is not included in the detection scheme for the indicator.

The major challenges with a detection algorithm are failing to detect a back-fed ground fault or wrongfully detect other fault types as a back-fed ground fault. This is why examples 3 through 5 have been included in the simulations performed. For the same reason different cases for example 1 and 2 were included. The percent values in Rules 1-3 are chosen to be about 0.05 p.u. above the highest values from the simulations. This to give a safety margin for the detection algorithm to include the and exclude the situations that can occur. For Rule 4, the margin is chosen to be $\pm 5^\circ$ above the most extreme values from the simulations. Rules 5-7 are meant to exclude other fault situations than those of the broken conductor and back-fed ground fault. The simulations done revealed that both a single line-to-ground fault and a double line-to-ground fault gives voltage outputs that can be detected as a back-fed ground fault or broken conductor. A single line-to-ground

on the secondary distribution system fault will normally contain a noticeable zero-sequence voltage whereas the broken conductor or the back-fed ground fault will have a zero-sequence voltage that is nearly zero.

As for the double line-to-ground fault, the zero-sequence voltage seen on the secondary side of the transformers will be very close to zero. Since a double line-to-ground appear as a short circuit, the conventional protection relays will clear this type of fault. In order to suppress a possible detection as a broken conductor / back-fed ground fault, time delay is included. This time delay will have to be a parameter than can be adjusted according to the protection scheme of the given distribution system.

CHAPTER 4
CONCLUSIONS, REMARKS AND RECOMMENDATIONS FOR
FUTURE WORK

4.1 Concluding remarks

This thesis makes use of the substantial volume of data available in the smart metering infrastructure to reveal a signature of voltages in the secondary distribution system during abnormal operating conditions. The voltage measurements on the low voltage side of a distribution transformer is found to have a certain *signature* during a specific fault situation when a conductor breaks and the downstream side of the conductor makes a path to ground. Using five examples for various faults conditions and distribution power system design a set of rules has been developed. Simulations using the free downloadable software OpenDSS has been performed on a test-bed with primary and secondary distribution system from a Norwegian utility. The freeware accommodates three phase detail and detailed models of transformers and other power distribution system components. OpenDSS is found to be ideal for studies of this kind.

A set of rules is formulated to detect both a sole broken conductor as well as a back-fed ground fault that can occur in the primary distribution system. Utilizing voltage magnitudes, phase angles and a time delay, the set of rules are as follows:

Rule 1. Two line-line voltages magnitude less than 65 % of rated voltage

(wye-wye/delta-delta)

Rule 2. One line-line voltage magnitude less than 40 % of rated voltage

(wye-delta/delta-wye)

Rule 3. One or two line-neutral magnitude above 80% of rated voltage
(all connection groups)

Rule 4. Angles between two line-line voltages differs by $145 - 215^\circ (\pm 35^\circ)$

Rule 5. Angles between any line-line voltage not equal to 120°

Rule 6. Vector sum of line-neutral voltages (zero-sequence voltage) less than
0.01 of rated voltage

Rule 7. Time delay of 3 seconds (after detection start)

Implementation of the rules can be done locally (i.e., at the distribution service) with algorithms at a distribution transformer using smart meter infrastructure or centralized at an event management system (e.g., at a distribution dispatch center) in the smart metering collection system. The use of detection in operations is suggested done through an integration of the smart metering collection system and a distribution management system (DMS). The location of the broken conductor or the back-fed ground fault uses the DMS as the interface for the operator at the electric utility distribution control center.

The detection of an abnormal situation as described has not been previously reported in the literature, and it is believed that the approach taken in this thesis is a contribution to the technology of smart metering and the use of smart grid elements in the distribution electric power system. Utilized by the electric utilities, a potential hazardous situation can be detected and located rapidly and help increase the safety to the general public. In addition the overall reliability of the operations of a distribution power system can be improved by faster locating fault location having the knowledge of the type of fault when sending out maintenance crew for fault repair.

4.2 Recommendations for future work

Future work is initially to implement the proposed solution and get real data to confirm and adapt the set of rules according to operational conditions. This is also the intent of the author upon returning to industry.

An idea for extended implementation use could be to geographically locate the fault location. For applications in rural areas (where the distances are great and separation between services and instrumentation may be great), it may be possible to identify fault location on an overhead line with use of other algorithms. Another similar use of the smart grid distribution technology to study is to use the smart meters at the point of end use to find similar detection algorithms for abnormal situations in the secondary distribution network. This implies especially to the grounding type systems that are denoted IT and TT in the report.

Additional areas of development with regards to the back-fed ground fault detection include:

- Impact of distributed renewable generation
- Impact of distributed / local use of Petersen coils in the distribution system.

A final recommendation is to publicize the main findings of this work via professional societies in Europe and North America. With this in mind, a draft technical paper is presently in preparation.

REFERENCES

- [1] Distribution Automation Handbook - Section 8.6 MV Feeder Earth-fault Protection, Available at:
[http://www05.abb.com/global/scot/scot229.nsf/veritydisplay/948f3fb78a335cb6c125795f0042ef8b/\\$file/dahandbook_section_08p06_feeder_ef_protection_757287_ena.pdf](http://www05.abb.com/global/scot/scot229.nsf/veritydisplay/948f3fb78a335cb6c125795f0042ef8b/$file/dahandbook_section_08p06_feeder_ef_protection_757287_ena.pdf)
- [2]"The Smart Grid: An introduction"
[http://energy.gov/sites/prod/files/oeprod/DocumentsandMedia/DOE_SG_Book_Single_Pages\(1\).pdf](http://energy.gov/sites/prod/files/oeprod/DocumentsandMedia/DOE_SG_Book_Single_Pages(1).pdf)
- [3] E. Tønne, J. Foosnæs, T. Pytten, "Power system planning in distribution networks today and in the future with smart grids," CIRED 22nd International Conference on Electricity Distribution, 2013, paper 1426.
- [4] D. Toader, C. Bjai and S. Haragus, " Electrocutation Danger Evaluation for Broken and Grounded Conductor," The International Conference on Computer as a Tool, EURO-CON, Sept 2007, pp. 1392-1397.
- [5] "Forskrift om måling, avregning og samordnet opptreden ved kraftomsetning og fakturering av netjtjenester," NVE, <http://lovdata.no/dokument/SF/forskrift/1999-03-11-301>
- [6] "Power distribution in Europe," Available at:
http://www.eurelectric.org/media/113155/dso_report-web_final-2013-030-0764-01-e.pdf
- [7] H. Nguyen, J. Burke, S. Benchluch, " Rural distribution system design comparison," IEEE Power Engineering Society Winter Meeting, vol. 4, January 2000, pp. 2357-2362.
- [8] "North American versus European distribution systems," Available at:
<http://electrical-engineering-portal.com/north-american-versus-european-distribution-systems>
- [9] "Electric distribution comparison – USA, Middle East, Europe," Available at:
<https://fyi.uwex.edu/mrec/files/2011/02/dist-compare-europe-mideast-usa-02061.pdf>
- [10] "Electricity – Distribution and Transmission," Available at:
<http://international-electrical-supplies.com/electricity-distribution.html>
- [11] "Overview of electricity distribution in Europe," Available at:
http://www.capgemini.com/resource-fileaccess/resource/pdf/tl_Overview_of_Electricity_Distribution_in_Europe.pdf

[12] A. Meliopoulos, J. Kennedy, C. Nucci and A. Borghetti, "Power distribution practices in USA and Europe: impact on power quality," 8th International Conference in Harmonics and Quality of Power Proceedings, vol. 1, October 1998, pp. 24-29.

[13] Schneider Electric Co., "MV public distribution networks throughout the world," Available at:
<http://www2.schneider-electric.com/documents/technical-publications/en/shared/electrical-engineering/electrical-networks/high-voltage-plus-1kv/ect155.pdf>

[14] A. L'Abbate, G. Fulli, F. Starr and S. Peteves, "Distributed power generation in Europe: Technical issues for further integration," JRC Scientific and Technical Reports, 2008, <http://bidelek.com/wp-content/uploads/2014/02/Distributed-Power-Generation-in-Europe-technical-issues-for-further-integration.pdf>

[15] Ministry of petroleum and energy, "The transmission and distribution grid," Available at:
<http://www.regjeringen.no/en/dep/oed/Subject/energy-in-norway/The-transmission-and-distribution-grid.html?id=444385>

[16] IEC 60364-1, "Low-voltage electrical installations – Part 1: Fundamental principles, assessment of general characteristics, definitions," November 2005.

[17] Schneider Electric Co., "Earthing systems worldwide and evolutions," Available at:
<http://www2.schneider-electric.com/documents/technical-publications/en/shared/electrical-engineering/dependability-availability-safety/low-voltage-minus-1kv/ect173.pdf>

[18] W. Petersen, "Limitation of earth current and suppression of earth fault arcs by the earthing coil" , ETZ Elektrotechnische Zeitschrift, vol. 40, 1919.

[19] R. N. Conwell and R. D. Evans, "The Petersen earth coil," Journal of the American Institute of Electrical Engineers, Feb. 1922, vol. 41. No. 2, pp. 140-148.

[20] J. Oliver and W. Eberhardt, "Operating performance of a Petersen earth coil," Transactions of the American Institute of Electrical Engineers, Jan. 1923, pp. 435-445

[21] K. Finch, "Petersen coil protection," Students' Quarterly Journal, Mar. 1936, vol. 6, No.23, pp. 138-141.

[22]H. Taylor and P. Stritzl, "Line protection by Petersen coils, with special reference to conditions prevailing in Great Britain, " Journal of Institution of Electrical Engineers, Apr. 1938, vol. 82, pp. 387-398.

- [23] L. Golds and C. Lipman, "A modern earth-fault relay equipment for use on systems protected by Petersen coils," *Journal of Institution of Electrical Engineers – Part II*, vol. 91, Oct. 1944, pp. 377-388
- [24] J. Sumner, "The theory and operation of Petersen coils", *Journal of Institution of Electrical Engineers – Part II*, vol. 94, Aug 1947, pp. 283-298.
- [25] Z. Xiangjun, Y. Xu and Y. Wang, "Some Novel Techniques for Insulation Parameters Measurement and Petersen-Coil Control in Distribution Systems," *IEEE Transactions on Industrial Electronics*, Apr. 2010, vol. 57, pp. 1445-1451.
- [26] A. Dán and D. Raisz, "Comparison of different methods for earth fault location in compensated networks," *Electric Power Quality and Supply Reliability Conference*, June 2010, pp. 237-242.
- [27] A. Cerretti, G. Di Lembo and G. Valtorta, "Improvement in the Continuity of Supply due to a Large Introduction of Petersen Coils in HV/MV Substations," *CIGRE 18th International Conference on Electricity Distribution*, June 2005, paper 0168.
- [28] G. Druml, A. Kugi and O. Seifert, "New Method to Control Petersen Coils by Injection of Two Frequencies," *CIGRE 18th International Conference on Electricity Distribution*, June 2005, paper 0399.
- [29] A. Mazon, I. Zamora, L. Zabala and F. Antepara, "First resonant neutral grounding implantation in Spanish distribution system," *IEEE Power Tech Proceedings*, Sept 2001, vol 4.
- [30] K. Papp and R. König, "Arc suppression coils – The key component of modern earth fault protection systems," *IEEE/PES Transmission and Distribution Conference and Exposition: Latin America*, 2010, pp. 366-371.
- [31] L. Weiguo, J. Shengchang and L. Yanming, "Identification of the distribution network's grounding status based on frequency track method," *Power and Energy Engineering Conference*, March 2010, pp. 1-5
- [32] J. Vico, M. Adamiak, C. Wester and A. Kulshrestha, "High impedance fault detection on rural electric distribution systems," *Rural Electric Power Conference*, May 2010, pp. B3 - B3-8
- [33] J. Roberts, H. Altuve and D. Hou, "Review of ground fault protection methods for grounded, ungrounded and compensated distribution systems," Available at <https://www.selinc.com/workarea/downloadasset.aspx?id=2604>

- [34] A. Pongthavornnsawad and W. Rungseevijitprapa, "Broken conductor detection for overhead line distribution system," Asia-Pacific Power and Energy Engineering Conference, Mar. 2011, pp.1-4
- [35] E. Bjerkan, H. K. Høidalen and J. G. Hernes, "Reliable detection of downed and broken conductor," CIRED 19th International Conference on Electricity Distribution, 2007, paper 0571.
- [36] L. Garcia – Santander, P. Bastard, M. Petit, I. Gal, E. Lopez and H. Opazo : "Down – conductor fault detection and location via a voltage based method for radial distribution networks," IEEE Proceedings on Generation, Transmission and Distribution, Vol. 152 No. 2, March 2005, pp. 180-184.
- [37] M. Yang, J. Gu, J. Guan, " Detection of downed conductor in distribution system," Power and Energy Engineering Conference, March 2010, pp. 1-5.
- [38] L. Li and M. Redfern, " A review of techniques to detect downed conductors in overhead distribution systems," Developments in Power System Protection, April 2001, pp. 169-172.
- [39] M. Adamiak, "Safety first: Detection of downed conductors and arcing on overhead distribution lines," Petroleum and Chemical Industry Technical Conference, Sept. 2008, pp. 1-8.
- [40] C. Benner and B. Russell, "Practical high-impedance fault detection on distribution feeders," IEEE Transactions on Industry Applications, vol. 3, June 1997, pp. 635-640.
- [41] A. Mamishev, B. Russell and C. Brenner, "Analysis of high impedance faults using fractal techniques," IEEE Power Industry Computer Application Conference, May 1995, pp. 401-406.
- [42] C. Wester, "High Impedance fault detection on distribution systems," Available at: <http://store.gedigitalenergy.com/faq/documents/dfp200/ger-3993.pdf>
- [43] S. Schinerl, "A New Sensitive Detection Algorithm for Low and High Impedance Earth Faults in Compensated MV Networks Based on the Admittance Method," CIRED 18th International Conference on Electricity Distribution, June 2005, paper 0615.
- [44] M. Redfern, Z. Bo and D. Montjean, "Detection of broken conductors using the positional protection technique," IEEE Power Engineering Society Summer Meeting, Jul 2001, vol.2, pp. 1163-1168.

- [45] OpenDSS Program, Sourceforge.net,
Available at <http://sourceforge.net/projects/electricdss/>
- [46] R. Dugan, "Reference Guide – The open distribution system simulator (OpenDSS)," EPRI, June 2013.
- [47] R. Dugan and T. McDermott, "An open source platform for collaborating on smart grid research," IEEE Power and Energy Society General Meeting, July 2011, pp. 1-7.
- [48] R. Arritt and R. Dugan, "Matching the IEEE Test Feeder short circuit results," IEEE Transmission and Distribution Conference and Exposition, May 2012, pp. 1-7.
- [49] J. Fuller, S. McHann and W. Sundeman, "Using open source modeling tools to enhance engineering analysis," IEEE Rural Electric Power Conference, May 2014, pp. 1-5.
- [50] R. Dugan, R. Arritt, T McDermott, S. Brahma and K. Schneider, " Distribution system analysis to support the Smart Grid," IEEE Power and Energy Society General Meeting, July 2010, pp. 1-8.
- [51] A. Awad, P. Bazan and R. German, "SGsim: A simulation framework for smart grid applications", IEEE International Energy Conference, May 2014, pp. 730-736.
- [52] C. Zhang and Y. Zeng, "Voltage and reactive power control method for distribution grid," IEEE Asia-Pacific Power and Energy Engineering Conference, Dec. 2013, pp. 1-6.
- [53] A. Anwar and H. Pota, "Optimum capacity allocation of DG units based on unbalanced three-phase optimal power flow," IEEE Power and Energy Society Meeting, July 2013, pp.1-8.
- [54] J. Smith, R. Dugan and W. Sundeman, "Distribution modeling and analysis of high penetration PV," IEEE Power and Energy Society General Meeting, July 2011, pp. 1-7.
- [55] S. Nie, X. Fu, P. Li, F. Gao, C. Ding, H. Yu and C. Wang, "Analysis of the impact of DG on distribution network reconfiguration using OpenDSS", IEEE Innovative Smart Grid Technologies – Asia, May 2012, pp. 1-5.
- [56] S. Solanki, V. Ramachandran and J. Solanki, "Steady state analysis of high penetration PV on utility distribution feeder," IEEE Transmission and Distribution Conference and Exposition, May 2012, pp. 1-6.
- [57] R. Tzartzev, W. Grady and J. Patel, "Impact of high-penetration PV on distribution feeders," IEEE International Conference on Innovative Smart Grid Technologies, Oct 2013, pp. 1-6.

- [58] P. Chirapongsananurak, S. Santoso, R. Dugan and J. Smith, "Voltage regulation in distribution circuits with wind power," IEEE Power and Energy Society Meeting, July 2012, pp. 1-8.
- [59] A. Anwar and H. Pota, "Loss reduction of power distribution network using optimum size and location of distributed generation," IEEE Australasian Universities Power Engineering Conference, Sept. 2011, pp. 1-6.
- [60] S. Alnaser and F. Ochoa, "Towards distribution energy management systems: Maximizing renewable DG," CIRED, June 2013, paper 1424
- [61] S. Bruno, S. Lamonaca, G. Rotondo and U. Stecchi, "Unbalanced Three-Phase Optimal Power Flow for Smart Grids," IEEE Transactions on Industrial Electronics, Oct 2011, pp. 4504-4513
- [62] D. Montenegro, M. Hernandez and G. Ramos, "Real time OpenDSS framework for distribution systems simulation and analysis," IEEE Transmission and Distribution: Latin America Conference and Exposition, Sept 2012, pp. 1-5
- [63] IEEE Std. 141-1993 - "IEEE Recommended Practice for Electric Power Distribution for Industrial Plants (IEEE Red Book)", Piscataway NJ, 1994
- [64] IEC 60076-1 Ed. 3.0 2011 - "International Standard for Power transformers Part 1: General", 2011.
- [65] C57.12.00-2010 - "IEEE Standard for General Requirements for Liquid-Immersed Distribution, Power, and Regulating Transformers," Piscataway NJ, 2010.
- [66] Private communication with electric Agder Energi Nett, Kristiansand, Norway, 2014.
- [67] K. Livik, N. Feilberg and J. Foosnæs, "Estimation of annual coincident peak demand and load curves based on statistical analysis and typical load data", CIRED - 12th International Conference on Electricity Distribution, May 1993, vol. 6, pp. 20/1-20/6.
- [68] "Kristiansand - a flourishing city", Available at:
<http://www.kristiansand.kommune.no/no/Om-Kristiansand/About-Kristiansand/>
- [69] Map of Northern Europe showing the city of Kristiansand, Norway, Available at:
<https://maps.yahoo.com/place/?lat=58.14389475246396&lon=7.9946136474609375&q=Kristiansand%2C%20Norway&bb=63.0151057%2C-8.32763672%2C53.27835302%2C24.27978516&addr=Kristiansand%2C%20Norway>

[70] "Big data on the Smart Grid: 2013 in review and 2014 outlook", Available at: <http://www.greentechmedia.com/articles/read/Big-Datas-5-Big-Steps-to-Smart-Grid-Growth-in-2014>

[71] "Managing big data for smart grids and smart meters", Available at: <http://www-01.ibm.com/common/ssi/cgi-bin/ssialias?infotype=SA&subtype=WH&htmlfid=IMW14628USEN>

[72] "Smart meters must better integrate into utility operations", Available at: <http://www.greentechmedia.com/articles/read/Smart-Meters-Must-Better-Integrate-Into-Utility-Operations>

[73] P. Wong, A. Kalam and R. Barr, "A "big data" challenge — Turning smart meter voltage quality data into actionable information", CIRED 22th International Conference on Electricity Distribution, June 2013, paper 0279

[74] M. Godoy Simnões, S. Mohagheghi, P. Siano and P. Palensky, "Advances in information technology for smart grids", 39th Annual Conference of the IEEE Industrial Electronics Society, Nov. 2013, pp. 36-41

[75] J. Sanchez, J. Arriola and H. Baroja, " A key point for the future challenges of the smartgrids: The architecture of the smart T-Station", CIRED Seminar 2008: Smart Grids for distribution, June 2013, paper 59.

[76] "Smartgrids, the energy system of the future", Available at: <http://www.sintef.no/home/SINTEF-Energy-Research/Xergi/Xergi-2012/Artikkel11/>

[77] Nortroll AS, "LineTroll 3200 Test Report: Laboratory test av EdF (Les Renardières)", Nortroll AS Norway, September 2006

[78] Private communication with technical personnel at Nortroll AS Norway, 2014, <http://www.nortroll.no>

APPENDIX A
OPENDSS CODE

A.1 General code for all examples in test bed

Master.dss file:

```
// Master file for 132/22kV circuit case

! Set frequency to 50 Hz
Set DefaultBaseFrequency=50

clear

new circuit.132-22-AEN basekv=132 p.u. =1.0 angle=0 frequency=50 phases=3
! Stiffen up to source to simulate a infinite bus on the source side of transformer
~ mvasc3=200000 200000

Redirect LineCodesNoNeutral.dss ! Open the definition file with line parameters
Redirect LinesNoNeutral.dss ! Open the line connection file
Redirect Transformers.dss ! Open the transformer definition file
Redirect Loads.dss ! Open the load definition file

! Voltage bases to have per unit results when visualising reports
! Rated voltages for the system model
set voltagebases=[132.0 23.0 0.415 0.24]
calc voltagebases

solve
```

Load.dss file:

```
! Normal max load parameters based on peak values from network information system
New Load.1 Bus1=2LV1 phases=3 kv=0.23 kw=14.071 kvar=2.960 model=1 conn=delta sta-
tus=fixed
New Load.2 Bus1=8LV1 phases=3 kv=0.23 kw=22.073 kvar=4.783 model=1 conn=delta sta-
tus=fixed
New Load.3 Bus1=6LV1 phases=3 kv=0.23 kw=23.047 kvar=5.044 model=1 conn=delta sta-
tus=fixed
New Load.4 Bus1=1LV1 phases=3 kv=0.23 kw=20.009 kvar=4.155 model=1 conn=delta sta-
tus=fixed
New Load.5 Bus1=10LV1 phases=3 kv=0.23 kw=18.895 kvar=4.107 model=1 conn=delta sta-
tus=fixed
New Load.6 Bus1=9LV1 phases=3 kv=0.23 kw=18.487 kvar=3.950 model=1 conn=delta sta-
tus=fixed
New Load.7 Bus1=13LV1 phases=3 kv=0.23 kw=21.036 kvar=4.506 model=1 conn=wye sta-
tus=fixed
New Load.8 Bus1=7LV1 phases=3 kv=0.23 kw=20.118 kvar=4.152 model=1 conn=delta sta-
tus=fixed
New Load.9 Bus1=3LV1 phases=3 kv=0.23 kw=83.529 kvar=18.166 model=1 conn=delta sta-
tus=fixed
New Load.10 Bus1=12LV1 phases=3 kv=0.23 kw=40.731 kvar=9.041 model=1 conn=delta sta-
tus=fixed
New load.11 Bus1=11LV1 phases=3 kv=0.23 kW=31.512 kvar=4.098 model=1 conn=delta sta-
```



```
tus=fixed
New Load.12 Bus1=5LV1 phases=3 kv=0.23 kw=17.564 kvar=3.759 model=1 conn=delta sta-
tus=fixed

New Load.13 Bus1=4LV1 phases=3 kv=0.23 kw=40.576 kvar=8.795 model=1 conn=delta sta-
tus=fixed
```

LineCodesNoNeutral.dss file:

```
! Lines in the test-bed distribution system
! All data is given in Ohms
! Zero sequence resistance and reactance are assumed to be the respective positive sequence times 3
! Zero sequence capacitance are assumed to be the positive sequence divided by 3

! 1kV lines and cables
new Linecode.EX1X4X95 nphases=4 R1=0.320 X1=0.076 R0=1.280 X0=0.427 C1=0.1 C0=0.0333
units=km
new Linecode.1X4X95AL nphases=3 R1=0.320 X1=0.075 R0=1.280 X0=0.329 C1=570 C0=16.667
units=km

! 22kV lines, cables and isolated lines
new Linecode.BLX1X95 nphases=3 R1=0.150 X1=0.310 R0=1.011 X0=0.93 C1=8.00 C0=2.667
units=km
new Linecode.FEAL1X25 nphases=3 R1=0.150 X1=0.394 R0=2.163 X0=1.182 C1=5.00 C0=1.667
units=km
new Linecode.TSLEAL3X1X150 nphases=3 R1=0.206 X1=0,12 R0=0.618 X0=0.36 C1=230.00
C0=76.667 units=km
new Linecode.TXSEAL3X1X240 nphases=3 R1=0.125 X1=0,18 R0=0.375 X0=0.54 C1=300.00 C0=100
units=km
new Linecode.TSLF3X1X50AL nphases=3 R1=0.641 X1=0,14 R0=1.923 X0=0.42 C1=160.00
C0=53.333 units=km
new Linecode.TSLF3X1X95AL nphases=3 R1=0.32 X1=0,12 R0=0.96 X0=0.36 C1=200.00 C0=66.667
units=km
new Linecode.AXCES1X3X70AL nphases=3 R1=0.443 X1=0.097 R0=1.329 X0=0.291 C1=210.00
C0=70 units=km
new Linecode.AXCES1X3X95AL nphases=3 R1=0.32 X1=0.097 R0=0.96 X0=0.291 C1=250.00
C0=83.333 units=km
```

LineNoNeutral.dss file:

```
! Line definitions in the system
! Overhead lines 22kV
New line.1 Bus1=7_11.1.2.3 Bus2=7_12.1.2.3 Length=0.957 Linecode=FEAL1X25
New line.2 Bus1=5.1.2.3 Bus2=6.1.2.3 Length=0.517 Linecode=FEAL1X25
New line.3 Bus1=4.1.2.3 Bus2=5.1.2.3 Length=0.487 Linecode=FEAL1X25
New line.4 Bus1=10.1.2.3 Bus2=10_1.1.2.3 Length=0.166 Linecode=FEAL1X25
New line.5 Bus1=7_12.1.2.3 Bus2=7_121.1.2.3 Length=0.095 Linecode=FEAL1X25
New line.6 Bus1=2.1.2.3 Bus2=3.1.2.3 Length=0.387 Linecode=BLX1X95
New line.7 Bus1=9.1.2.3 Bus2=10.1.2.3 Length=0.775 Linecode=FEAL1X25
New line.8 Bus1=8.1.2.3 Bus2=9.1.2.3 Length=0.029 Linecode=FEAL1X25
New line.9 Bus1=7.1.2.3 Bus2=7_1.1.2.3 Length=0.257 Linecode=FEAL1X25
New line.10 Bus1=7.1.2.3 Bus2=8.1.2.3 Length=0.949 Linecode=FEAL1X25
```

```

New line.11 Bus1=6.1.2.3 Bus2=7.1.2.3 Length=0.102 Linecode=FEAL1X25
New line.12 Bus1=10.1.2.3 Bus2=11.1.2.3 Length=0.03 Linecode=FEAL1X25
New line.13 Bus1=3.1.2.3 Bus2=4.1.2.3 Length=0.912 Linecode=BLX1X95
New line.14 Bus1=7_1.1.2.3 Bus2=7_11.1.2.3 Length=0.585 Linecode=FEAL1X25

! Underground cables 22kV
New line.15 Bus1=16.1.2.3 Bus2=17.1.2.3 Length=0.023 Linecode=TSLF3X1X95AL
New line.16 Bus1=5.1.2.3 Bus2=5_1.1.2.3 Length=0.012 Linecode=TSLEAL3X1X50
New line.17 Bus1=1.1.2.3 Bus2=2.1.2.3 Length=0.112 Linecode=TXSEAL1X3X240
New line.18 Bus1=8.1.2.3 Bus2=8_1.1.2.3 Length=0.022 Linecode=TSLF3X1X50AL

! Isolated overhead lines 22kV
New line.19 Bus1=15.1.2.3 Bus2=16.1.2.3 Length=0.078 Linecode=AXCES1X3X70AL
New line.20 Bus1=11.1.2.3 Bus2=12.1.2.3 Length=1.196 Linecode=AXCES1X3X70AL
New line.21 Bus1=12.1.2.3 Bus2=12_1.1.2.3 Length=0.708 Linecode=AXCES1X3X70AL
New line.22 Bus1=12_1.1.2.3 Bus2=12_F.1.2.3 Length=0.900 Linecode=AXCES1X3X70AL
New line.22a Bus1=12_F.1.2.3 Bus2=12_2.1.2.3 Length=0.004 Linecode=AXCES1X3X70AL
New line.23 Bus1=7_12.1.2.3 Bus2=7_13.1.2.3 Length=1.13 Linecode=AXCES1X3X70AL
New line.24 Bus1=7_13.1.2.3 Bus2=7_14.1.2.3 Length=0.707 Linecode=AXCES1X3X70AL
New line.25 Bus1=12.1.2.3 Bus2=13.1.2.3 Length=1.692 Linecode=AXCES1X3X70AL
New line.26 Bus1=13.1.2.3 Bus2=14.1.2.3 Length=1.21 Linecode=AXCES1X3X70AL
New line.27 Bus1=14.1.2.3 Bus2=14_1.1.2.3 Length=1.504 Linecode=AXCES1X3X70AL
New line.28 Bus1=14.1.2.3 Bus2=15.1.2.3 Length=0.682 Linecode=AXCES1X3X70AL

! Underground cables 1kV
New line.29 Bus1=1LV.1.2.3 Bus2=1LV1.1.2.3 Length=0.5 Linecode=1X4X95AL
New line.30 Bus1=2LV.1.2.3 Bus2=2LV1.1.2.3 Length=0.5 Linecode=1X4X95AL
New line.31 Bus1=3LV.1.2.3 Bus2=3LV1.1.2.3 Length=0.5 Linecode=1X4X95AL
New line.32 Bus1=4LV.1.2.3 Bus2=4LV1.1.2.3 Length=0.5 Linecode=1X4X95AL
New line.33 Bus1=5LV.1.2.3 Bus2=5LV1.1.2.3 Length=0.5 Linecode=1X4X95AL
New line.34 Bus1=6LV.1.2.3 Bus2=6LV1.1.2.3 Length=0.5 Linecode=1X4X95AL
New line.35 Bus1=7LV.1.2.3 Bus2=7LV1.1.2.3 Length=0.5 Linecode=1X4X95AL

! Overhead lines 1kV
New line.36 Bus1=8LV.1.2.3 Bus2=8LV1.1.2.3 Length=0.5 Linecode=EX1X4X95
New line.37 Bus1=9LV.1.2.3 Bus2=9LV1.1.2.3 Length=0.5 Linecode=EX1X4X95
New line.38 Bus1=10LV.1.2.3 Bus2=10LV1.1.2.3 Length=0.5 Linecode=EX1X4X95
New line.39 Bus1=11LV.1.2.3 Bus2=11LV1.1.2.3 Length=0.5 Linecode=EX1X4X95
New line.40 Bus1=12LV.1.2.3 Bus2=12LV1.1.2.3 Length=0.5 Linecode=EX1X4X95
New line.41 Bus1=13LV.1.2.3 Bus2=13LV11.1.2.3 Length=0.01 Linecode=EX1X4X95 ! Fault bus for
1ph-gnd fault
New line.42 Bus1=13LV11.1.2.3 Bus2=13LV1.1.2.3 Length=0.5 Linecode=EX1X4X95

```

Transformers.dss file:

```

!*****
! Substation transformer
!*****

new transformer.T1 phases=3 windings=2
~ conns=(wye, wye) kvs=(132, 23) kvas=(25000, 25000) xhl=11.545 %loadloss=0.352
~ maxtap=1.1336 mintap=0.8 %Noloadloss=0.044 !On both windings, so total = 0.088 %
~ wdg=1 bus=sourcebus.1.2.3.4 Rneut=-1 %r=0.175 ! %r half on each winding

```

~ wdg=2 bus=1.1.2.3.4 %r=0.175 !Rneut=-1 !Rneut = 50 xneut=0.6469 ! 0.6469 Ohms at 16A/50Hz & 6.469 Ohms at 160/50Hz

! Arc suppression coil / Peterson coil - 160A

New Reactor.P1 phases=1 bus1=1.4 bus2=1.0 kV=12.7 kvar=357.7 ! 2032 kVAr for 160 A 325.2 kVAr for 25.6A ! 10% over = 357.7 kVAr & 10 % under = 292.6 kVAr

!*****!
*****! Distribution transformers in the feeder
!*****!
*****!

! TT-system (Grounded Neutral)

!-----

! YNYn0 configuration - transformers 1/2/3/4/11

! MV-side is isolated (R=-1) and LV side is grounded

!-----

New Transformer.1 phases=3 windings=2 buses=(17, 1LV)

~ conns=(wye, wye) kvs=(22, 0.24) kvas=(100, 100) %loadloss=1.273 xhl=3,57 maxtap=1.10 mintap=0.90 %Noloadloss=0.211

~ wdg=1 bus=17.1.2.3.4 Rneut=-1 %r=0.635

~ wdg=2 bus=1LV.1.2.3.0 %r=0.635 ! Half load loss on each winding. Total %r= 1.27

New Transformer.2 phases=3 windings=2 buses=(7_11, 2LV)

~ conns=(wye, wye) kvs=(22, 0.24) kvas=(50, 50) %loadloss=1.758 xhl=3,86 maxtap=1.10 mintap=0.90 %Noloadloss=0.298

~ wdg=1 bus=7_11.1.2.3.4 Rneut=-1 %r=0.88

~ wdg=2 bus=2LV.1.2.3.0 %r=0.88 ! Half load loss on each winding. Total %r= 1.76

New Transformer.3 phases=3 windings=2 buses=(8_1, 3LV)

~ conns=(wye, wye) kvs=(22, 0.24) kvas=(200, 200) %loadloss=1.0765 xhl=3,75 maxtap=1.10 mintap=0.90 %Noloadloss=0.189

~ wdg=1 bus=8_1.1.2.3.4 Rneut=-1 %r=0.54

~ wdg=2 bus=3LV.1.2.3.0 %r=0.54 ! Half load loss on each winding. Total %r= 1.08

New Transformer.4 phases=3 windings=2 buses=(7_121, 4LV)

~ conns=(wye, wye) kvs=(22, 0.24) kvas=(100, 100) %loadloss=1.473 xhl=3,93 maxtap=1.10 mintap=0.90 %Noloadloss=0.222

~ wdg=1 bus=7_121.1.2.3.4 Rneut=-1 %r=0.735

~ wdg=2 bus=4LV.1.2.3.0 %r=0.735 ! Half load loss on each winding. Total %r= 1.47

New Transformer.11 phases=3 windings=2 buses=(3, 11LV)

~ conns=(wye, wye) kvs=(22, 0.24) kvas=(30, 30) %loadloss=2.08 xhl=3,2 maxtap=1.00 mintap=1.00 %Noloadloss=0.38

~ wdg=1 bus=3.1.2.3.4 Rneut=-1 %r=1.045

~ wdg=2 bus=11LV.1.2.3.0 %r=1.045 ! Half load loss on each winding. Total %r= 2.09

!-----

! IT-system (Isolated Neutral)

!-----

! YNYn0 configuration - Transformers 5/6/7/8/9

! MV-side is isolated (R=-1) and LV side is isolated(R=-1)

!-----

New Transformer.5 phases=3 windings=2 buses=(7_14, 5LV)

~ conns=(wye, wye) kvs=(22, 0.24) kvas=(50, 50) %loadloss=1.622 xhl=3,97 maxtap=1.05 mintap=0.95 %Noloadloss=0.292

~ wdg=1 bus=7_14.1.2.3.4 Rneut=-1 %r=0.81

~ wdg=2 bus=5LV.1.2.3.4 Rneut=-1 %r=0.81 ! Half load loss on each winding. Total %r= 1.62

```

New Transformer.6 phases=3 windings=2 buses=(10_1, 6LV)
~ conns=(wye, wye) kvs=(22, 0.24) kvas=(50, 50) %loadloss=1.536 xhl=3,98 maxtap=1.05 mintap=0.95
%Noloadloss=0.244
~ wdg=1 bus=10_1.1.2.3.4 Rneut=-1 %r=0.77
~ wdg=2 bus=6LV.1.2.3.4 Rneut=-1 %r=0.77 ! Half load loss on each winding. Total %r= 1.54
New Transformer.7 phases=3 windings=2 buses=(7_13, 7LV)
~ conns=(wye, wye) kvs=(22, 0.23) kvas=(100, 100) %loadloss=2.019 xhl=3,93 maxtap=1.05 mintap=0.95
%Noloadloss=0.326
~ wdg=1 bus=7_13.1.2.3.4 Rneut=-1 %r=1.01
~ wdg=2 bus=7LV.1.2.3.4 Rneut=-1 %r=1.01 ! Half load loss on each winding. Total %r= 2.02
New Transformer.8 phases=3 windings=2 buses=(5_1, 8LV)
~ conns=(wye, wye) kvs=(22, 0.23) kvas=(50, 50) %loadloss=2.014 xhl=3,88 maxtap=1.05 mintap=0.95
%Noloadloss=0.36
~ wdg=1 bus=5_1.1.2.3.4 Rneut=-1 %r=0.83
~ wdg=2 bus=8LV.1.2.3.4 Rneut=-1 %r=0.83 ! Half load loss on each winding. Total %r= 1.66
New Transformer.9 phases=3 windings=2 buses=(12_1, 9LV)
conns=(wye, wye) kvs=(22, 0.24) kvas=(50, 50) %loadloss=1.592 xhl=3,86 maxtap=1.05 mintap=0.95
%Noloadloss=0.424
~ wdg=1 bus=12_1.1.2.3.4 Rneut=-1 %r=0.795
~ wdg=2 bus=9LV.1.2.3.4 Rneut=-1 %r=0.795 ! Half load loss on each winding. Total %r= 1.59

!-----
! TN-system (Terra Neutral with PEN conductor)
!-----
! Dyn11 configuration - Transformers 13
!-----

New XFMRCODE.1phTr Phases=1 Windings=2 %loadloss=2.14 xhl=3,25 maxtap=1.00 mintap=1.00
%Noloadloss=0.8
~ wdg=1 kV = 22 kVA=100 conn=delta %r=1.0
~ wdg=2 kV=0.230 kVA=100 conn=wye %r=1.0

New Transformer.Phase_A Xfmrcode=1phTr Buses=[12_2.1.2 13LV.1.0]
New Transformer.Phase_B Xfmrcode=1phTr Buses=[12_2.2.3 13LV.2.0]
New Transformer.Phase_C Xfmrcode=1phTr Buses=[12_2.3.1 13LV.3.0]

!-----
! TN-system (Terra Neutral with PEN conductor)
!-----
! Dd0 configuration - Transformers 10/12
!-----

New Transformer.12 phases=3 windings=2 buses=(6, 12LV)
~ conns=(delta, delta) kvs=(22, 0.230) kvas=(50, 50) %loadloss=2.368 xhl=3,7 maxtap=1.00 mintap=1.00
%Noloadloss=0.874
~ wdg=1 bus=6.1.2.3 %r=1.185
~ wdg=2 bus=12LV.1.2.3 %r=1.185 ! Half load loss on each winding. Total %r= 2.37

New Transformer.10 phases=3 windings=2 buses=(14_1, 10LV)
~ conns=(delta, delta) kvs=(22, 0.23) kvas=(50, 50) %loadloss=2.2 xhl=3,86 maxtap=1.03 mintap=1.00
%Noloadloss=1.06
~ wdg=1 bus=14_1.1.2.3 %r=1.1
~ wdg=2 bus=10LV.1.2.3 %r=1.1 ! Half load loss on each winding. Total %r= 2.2

```

A.2 Code: example 1 – Broken conductor

Master.dss file:

```
// Master file for 132/22kV circuit case

! Set frequency to 50 Hz
Set DefaultBaseFrequency=50

clear

new circuit.132-22-AEN basekv=132 p.u. =1.0 angle=0 frequency=50 phases=3
! Stiffen up to source to simulate a infinite bus on the source side of transformer
~ mvasc3=200000 200000

Redirect LineCodesNoNeutral.dss
Redirect LinesNoNeutral.dss
Redirect Transformers.dss
Redirect Loads.dss

! Voltage bases to have per unit results when visualising reports
! Rated voltages for the system model
set voltagebases=[132.0 23.0 0.415 0.24]
calc voltagebases

solve

! Simulate a broken conductor on downstream bus of the line in phase 1 in case 1
Open LINE.6 2 1
solve

show voltages LL Nodes          ! Shows all line-line voltages
show voltages LN Nodes          ! Shows all line-neutral voltages
show currents residual=yes Elements ! Shows all phase currents
show currents sequence
show voltages sequence
```

Similar for case 2 and special case where the 'open' command is replaced by:

```
! Simulate a broken conductor on downstream bus of the line in phase 1 in case 2 of example 1
Open LINE.20 2 1
```

```
! Simulate a broken conductor on downstream bus of the line in phase 1 in special case of example 1
Open LINE.26 2 1
```

A.3 Code for example 2 – Back-fed ground fault

Master.dss file:

```
// Master file for 132/22kV circuit case

! Set frequency to 50 Hz
Set DefaultBaseFrequency=50

clear

new circuit.132-22-AEN basekv=132 p.u. =1.0 angle=0 frequency=50 phases=3
! Stiffen up to source to simulate a infinite bus on the source side of transformer
~ mvasc3=200000 200000

Redirect LineCodesNoNeutral.dss
Redirect LinesNoNeutral.dss
Redirect Transformers.dss
Redirect Loads.dss

! Voltage bases to have per unit results when visualising reports
! Rated voltages for the system model
set voltagebases=[132.0 23.0 0.415 0.24]
calc voltagebases

solve

! Simulate a broken conductor with 1ph-gnd fault on downstream side for phase 1 in line 6
LINE.6.Bus1=2.0.2.3          ! fase 1 with fault
solve

show voltages LL Nodes          ! Shows all line-line voltages
show voltages LN Nodes          ! Shows all line-neutral voltages
show currents residual=yes Elements ! Shows all phase currents
show currents sequence
show voltages sequence
```

Similar for case 2 and 3 where the 'LINE' command is replaced by:

```
! Simulate a broken conductor with 1ph-gnd fault on downstream side for phase 1 in line 20
LINE.20.Bus1=11.0.2.3          ! fase 1 with fault
```

```
! Simulate a broken conductor with 1ph-gnd fault on downstream side for phase 1 in line 15
LINE.15.Bus1=16.0.2.3          ! fase 1 with fault
```

```
! Simulate a broken conductor with 1ph-gnd fault on downstream side for phase 1 in line 27
LINE.27.Bus1=14.0.2.3          ! fase 1 with fault
```

```
! Simulate a broken conductor with 1ph-gnd fault on downstream side for phase 1 in line 21
LINE.21.Bus1=12.0.2.3          ! fase 1 with fault
```

A.4 Code for example 3 – Single line-to-ground fault primary distribution system

Master.dss file:

```
// Master file for 132/22kV circuit case

! Set frequency to 50 Hz
Set DefaultBaseFrequency=50

clear

new circuit.132-22-AEN basekv=132 p.u. =1.0 angle=0 frequency=50 phases=3
! Stiffen up to source to simulate a infinite bus on the source side of transformer
~ mvasc3=200000 200000

Redirect LineCodesNoNeutral.dss
Redirect LinesNoNeutral.dss
Redirect Transformers.dss
Redirect Loads.dss

! Voltage bases to have per unit results when visualising reports
! Rated voltages for the system model
set voltagebases=[132.0 23.0 0.415 0.24]
calc voltagebases

solve

! Single line-to-ground fault at bus 6 phase 1 – MV system
new Fault.F1 bus 1=6.1 phases=1
solve

show voltages LL Nodes           ! Shows all line-line voltages
show voltages LN Nodes           ! Shows all line-neutral voltages
show currents residual=yes Elements ! Shows all phase currents
show currents sequence
show voltages sequence
```

For the 40 Ω special case the 'new Fault' command is replaced with:

```
! Single line-to-ground fault at bus 6 phase 1
new Fault.F1 bus 1=6.1 phases=1 r=40
```

A.5 Code for example 4 – Single line-to-ground fault secondary distribution system

Master.dss file:

```
// Master file for 132/22kV circuit case

! Set frequency to 50 Hz
Set DefaultBaseFrequency=50

clear

new circuit.132-22-AEN basekv=132 p.u. =1.0 angle=0 frequency=50 phases=3
! Stiffen up to source to simulate a infinite bus on the source side of transformer
~ mvasc3=200000 200000

Redirect LineCodesNoNeutral.dss
Redirect LinesNoNeutral.dss
Redirect Transformers.dss
Redirect Loads.dss

! Voltage bases to have per unit results when visualising reports
! Rated voltages for the system model
set voltagebases=[132.0 23.0 0.415 0.24]
calc voltagebases

solve

! Single line-to-ground fault at bus 13LV phase 1 – LV system
new Fault.F1 bus 1=13LV.1 phases=1
solve

show voltages LL Nodes           ! Shows all line-line voltages
show voltages LN Nodes           ! Shows all line-neutral voltages
show currents residual=yes Elements ! Shows all phase currents
show currents sequence
show voltages sequence
```

For other grounded LV type systems in the test-bed the 'new fault' command is replaced with:

```
! Single line-to-ground fault at bus 9LV phase 1 – LV system
new Fault.F1 bus 1=9LV.1 phases=1
```

```
! Single line-to-ground fault at bus 10LV phase 1 – LV system
new Fault.F1 bus 1=10LV.1 phases=1
```

```
! Single line-to-ground fault at bus 11LV phase 1 – LV system
new Fault.F1 bus 1=11LV.1 phases=1
```

A.6 Code for example 5 – Double line-to-ground fault primary distribution system

Master.dss file:

```
// Master file for 132/22kV circuit case

! Set frequency to 50 Hz
Set DefaultBaseFrequency=50

clear

new circuit.132-22-AEN basekv=132 p.u. =1.0 angle=0 frequency=50 phases=3
! Stiffen up to source to simulate a infinite bus on the source side of transformer
~ mvasc3=200000 200000

Redirect LineCodesNoNeutral.dss
Redirect LinesNoNeutral.dss
Redirect Transformers.dss
Redirect Loads.dss

! Voltage bases to have per unit results when visualising reports
! Rated voltages for the system model
set voltagebases=[132.0 23.0 0.415 0.24]
calc voltagebases

solve

! Short circuit line to line fault MV 2ph-ground at bus 7
new Fault.F1 bus 1=7.1.2 phases=2
solve

show voltages LL Nodes           ! Shows all line-line voltages
show voltages LN Nodes           ! Shows all line-neutral voltages
show currents residual=yes Elements ! Shows all phase currents
show currents sequence
show voltages sequence
```